

Technical data Hydraulic lift crane

LR 1160
Litronic®

Complies with ANSI/ASME B 30.5

1003.03



LIEBHERR

Courtesy of Crane.Market

Dimensions

Basic machine with undercarriage

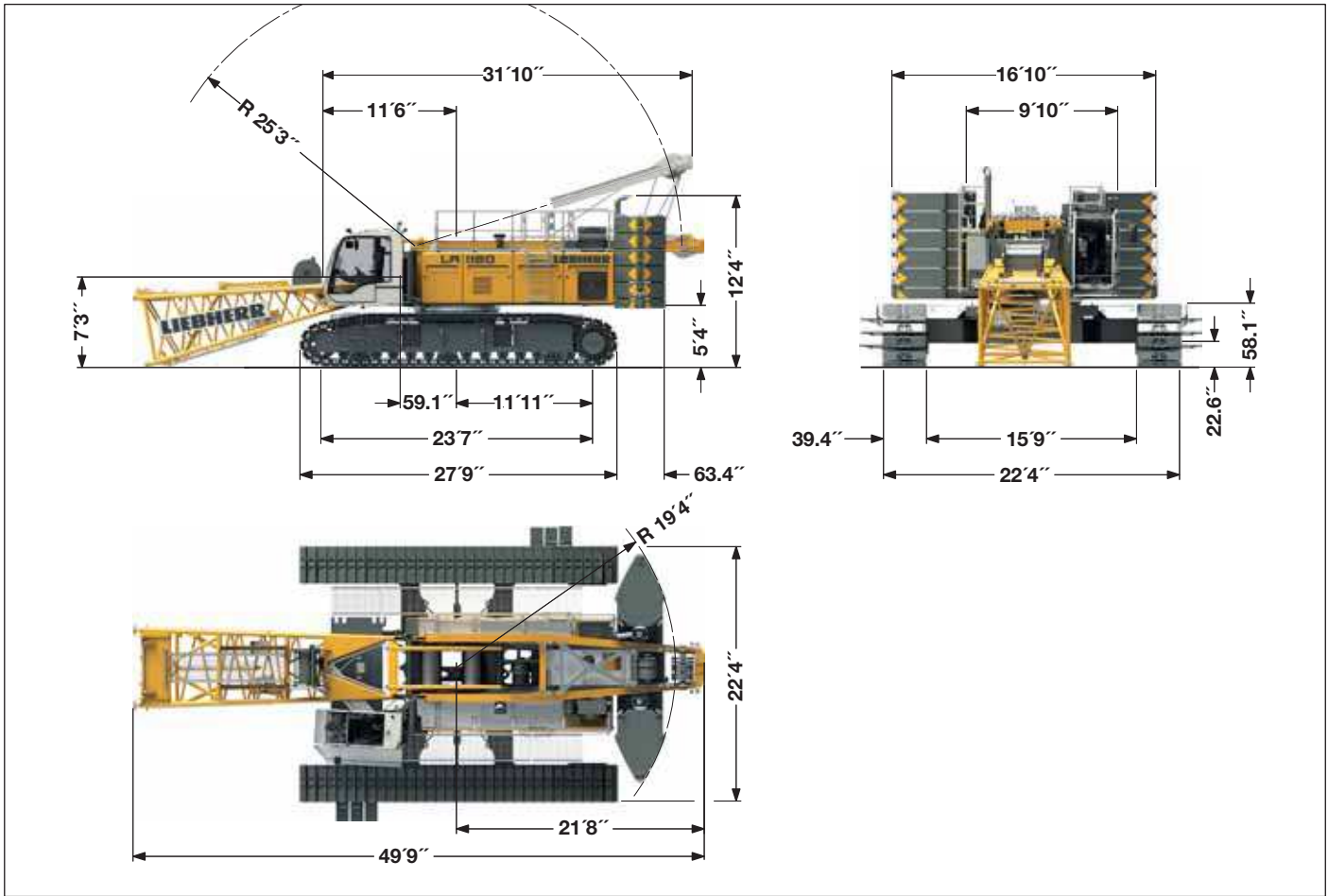

Operating weight

The operating weight includes the basic machine with crawlers, 2 main winches 26,980 lbf and 65.6 ft main boom, consisting of A-frame, boom foot (23 ft), boom head (23 ft), boom extension (20 ft), 137,400 lbs basic counterweight, 44,100 lbs carbody counterweight and 353,000 lbs hook block.
 Total weight _____ approx. 368,200 lbs

Ground pressure

Ground bearing pressure _____ 16.49 PSI

Equipment

Main boom (No. 2018.xx) max. length	_____	287 ft
High reach (No. 2018.xx and 1309.xx)	_____	344 ft
High reach (No. 2018.xx and 1713.xx)	_____	332 ft
Luffing jib (No. 1309.xx) max. length	_____	258 ft
Max. combination	_____ main boom	181 ft
	_____ luffing jib	258 ft
Luffing jib (No. 1713.xx) max. length	_____	272 ft
Max. combination	_____ main boom	171 ft
	_____ luffing jib	258 ft
Fixed jib (No. 0806.xx)	_____	36 ft - 105 ft
Fixed jib (No. 1008.xx)	_____	36 ft - 85 ft
Auxiliary jib	_____	53,000 lbs (option 79,400 lbs)

Remarks

- The lifting capacities stated are valid for lifting operation only (corresponding with crane classification according to F.E.M. 1.001. crane group A1).
- Crane standing on firm, horizontal ground.
- The weight of the lifting device (hoisting ropes, hook block, shackle etc.) must be deducted from the gross lifting capacity to obtain a net lifting value.
- Additional equipment on boom (e.g. boom walkways, auxiliary jib) must be deducted to get the net lifting capacity.
- For max. wind speed please refer to lift chart in operator's cab or manual.
- Working radii are measured from center of swing and under load.
- The lifting capacities are valid for 360 degrees of swing.
- Calculation of stability under load is based on ANSI/ASME B 30.5 load ratings as well as ISO 4305 Table 2 and is tested according to SAE J765.
- Loads for calculation of structures are corresponding to F.E.M. 1.001-1998 and are tested according to SAE J987.

Transport dimensions and weights

Basic machine and main boom (No. 2018.xx)

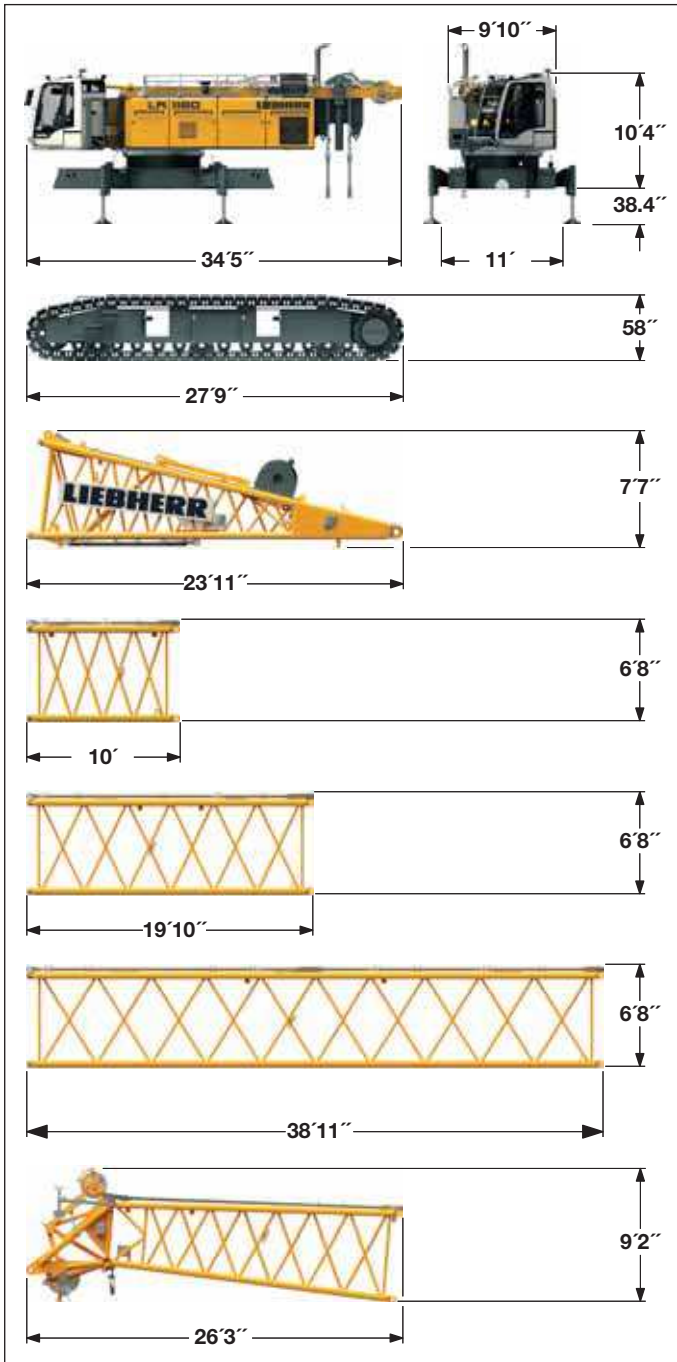

1) Pendant straps for main boom • 2) Pendant straps for jib

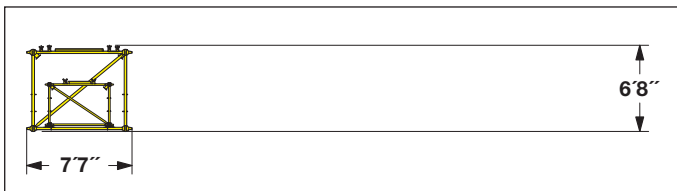

^{*)} Including pendant straps

Basic machine

with A-frame, 2x 26,780 lbf crane winches without boom foot, hoist ropes, basic counterweight and crawlers

Width	9'10"
Weight	77,160 lbs
Weight of hoist rope	2.28 lbs/ft

Crawler

2 x

Track pads	39.4 inch
Width	46.5 inch
Weight	38,055 lbs

Boom foot (No. 2018.23)

Width	7'
Weight without winch	6,600 lbs
Weight incl. winch and rope	10,050 lbs

Boom section (No. 2018.20)

10 ft

Width	7'
Weight with HPT ¹⁾	1,500 lbs
Weight with HPT ¹⁾ and NDL ²⁾	1,655 lbs

Boom section (No. 2018.20)

20 ft

Width	7'
Weight with HPT ¹⁾	2,185 lbs
Weight with HPT ¹⁾ and NDL ²⁾	2,425 lbs

Boom section (No. 2018.20)

38 ft

Width	7'
Weight with HPT ¹⁾	5,480 lbs
Weight with HPT ¹⁾ and NDL ²⁾	4,190 lbs

Boom head (No. 2018.20)

Width	7'
Weight with HPT ¹⁾	6,400 lbs

Boom transport option

38 ft boom - and 38 ft jib extension
20 ft boom - and 20 ft jib extension

(No. 2018.xx/1309.xx)	20 ft/20 ft	38 ft/38 ft
Length	20'2"	38'11"
Weight*	3,575 lbs	6,305 lbs

Transport dimensions and weights

Luffing jib (No. 1309.xx)

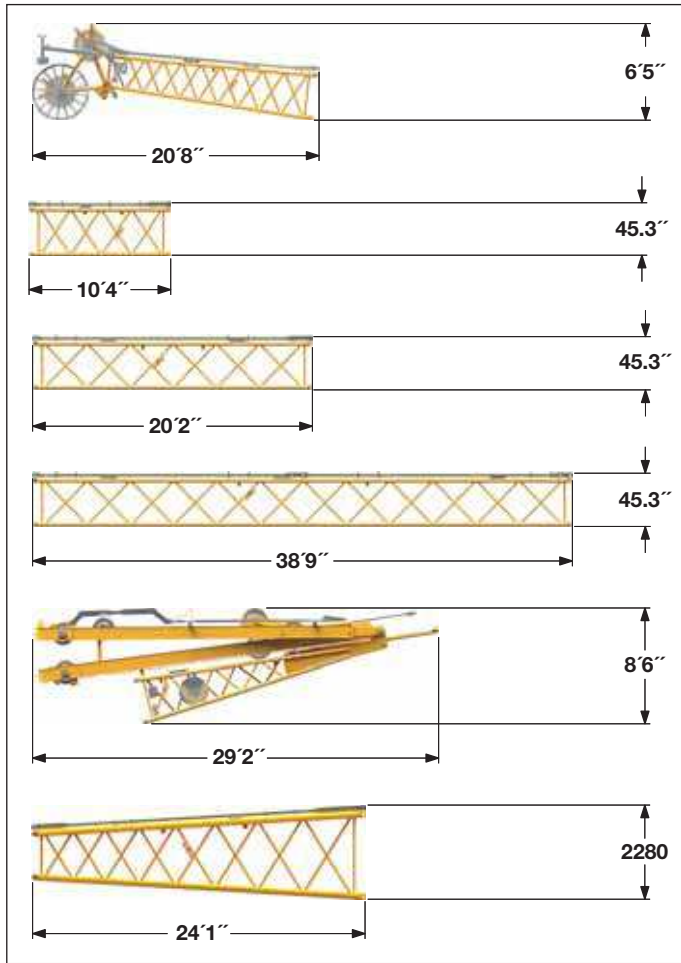

Luffing jib head (No. 1309.22)

Width	54.7 inch
Weight*	3,530 lbs

Luffing jib section (No. 1309.20) 10 ft

Width	54.7 inch
Weight*	926 lbs

Luffing jib section (No. 1309.20) 20 ft

Width	54.7 inch
Weight*	1,150 lbs

Luffing jib section (No. 1309.20) 38 ft

Width	54.7 inch
Weight*	2,120 lbs

Luffing jib foot with A-frames (No. 1309.22)

Width	5'7"
Weight*	9,810 lbs

Boom section tapered (No. 2018/1309.20) 23.6 ft

Width	7'
Weight*	2,340 lbs

Fixed jib (No. 0806.xx)

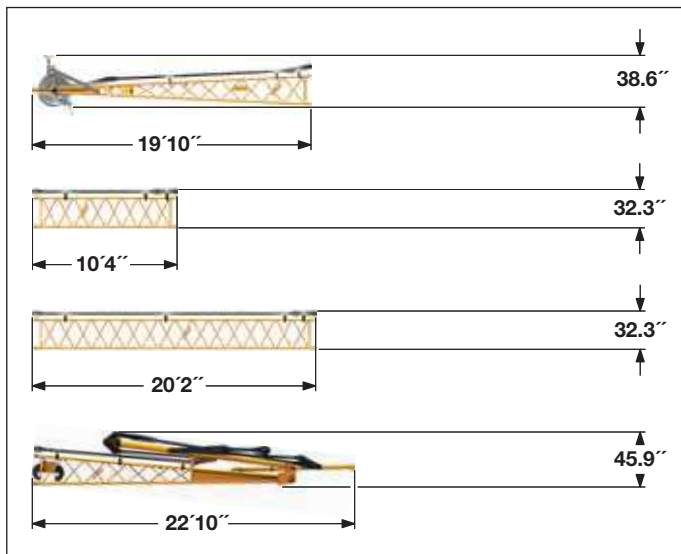

Fixed jib head (No. 0806.16)

Width	37.4 inch
Weight*	1,015 lbs

Fixed jib section (No. 0806.15) 10 ft

Width	37.4 inch
Weight*	320 lbs

Fixed jib section (No. 0806.15) 20 ft

Width	37.4 inch
Weight*	550 lbs

Fixed jib foot with A-frame (No. 0806.16)

Width	7'3"
Weight*	2,295 lbs

* Including pendant straps

Transport dimensions and weights

Luffing jib (No. 1713.xx)

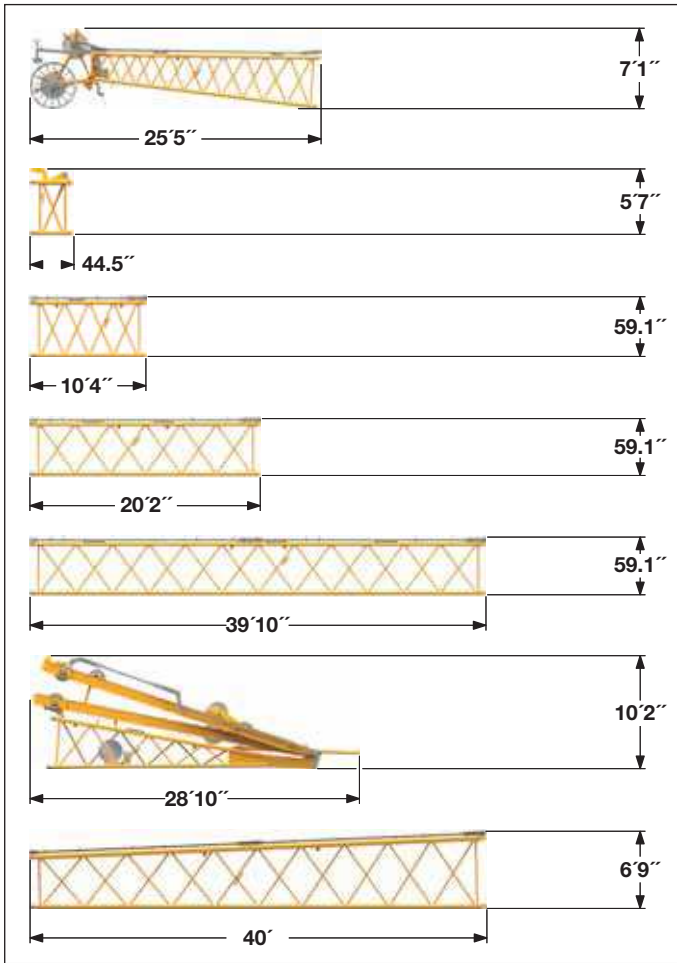

Luffing jib head (No. 1713.21)

Width	6'
Weight*	3,035 lbs

L-boom jib section (No. 1713.22) 39.4 inch

Width	6'
Weight*	870 lbs

Luffing jib section (No. 1713.18) 10 ft

Width	6'
Weight*	950 lbs

Luffing jib section (No. 1713.18) 20 ft

Width	6'
Weight*	1,390 lbs

Luffing jib section (No. 1713.18) 40 ft

Width	6'
Weight*	2,515 lbs

Luffing jib foot with A-frames (No. 1713.22)

Width	6'
Weight*	10,185 lbs

Boom section tapered (No. 1713.22) 40 ft

Width	7'
Weight*	3,285 lbs

Fixed jib (No. 1008.xx)

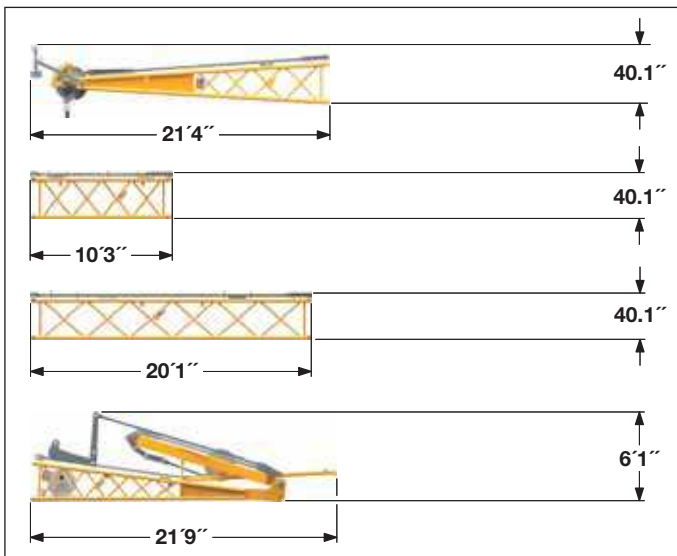

Fixed jib head (No. 1008.20)

Width	43 inch
Weight*	2,030 lbs

Fixed jib section (No. 1008.17) 10 ft

Width	43 inch
Weight*	660 lbs

Fixed jib section (No. 1008.17) 20 ft

Width	43 inch
Weight*	1,005 lbs

Fixed jib foot with A-frame (No. 1008.20)

Width	7'3"
Weight*	4,300 lbs

* Including pendant straps

Transport dimensions and weights

Counterweight

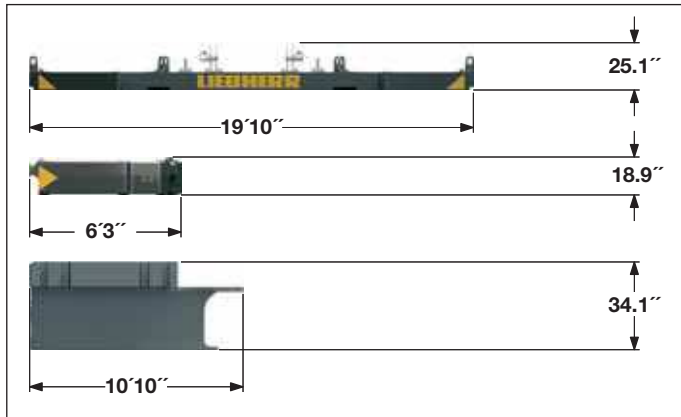

Counterweight **1 x**

Width	53.5 inch
Weight	26,455 lbs

Counterweight **10 x**

Width	53.5 inch
Weight	11,025 lbs

Carbody counterweight **2 x**

Width	9'11"
Weight	22,050 lbs

Mid fall

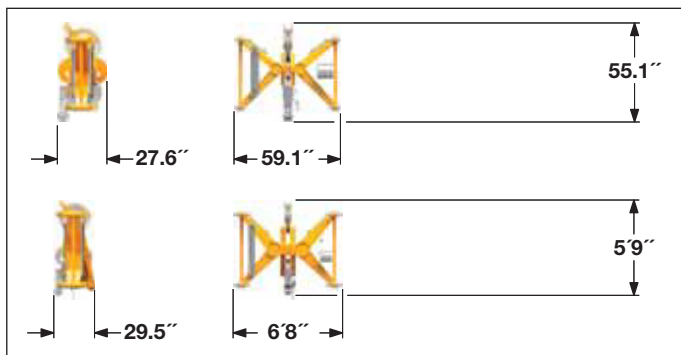

Mid fall section (No. 1309.32) **13.8 inch**

Width	27.6 inch
Weight	595 lbs

Mid fall section (No. 1713.31) **19.7 inch**

Width	27.6 inch
Weight	850 lbs

Hooks

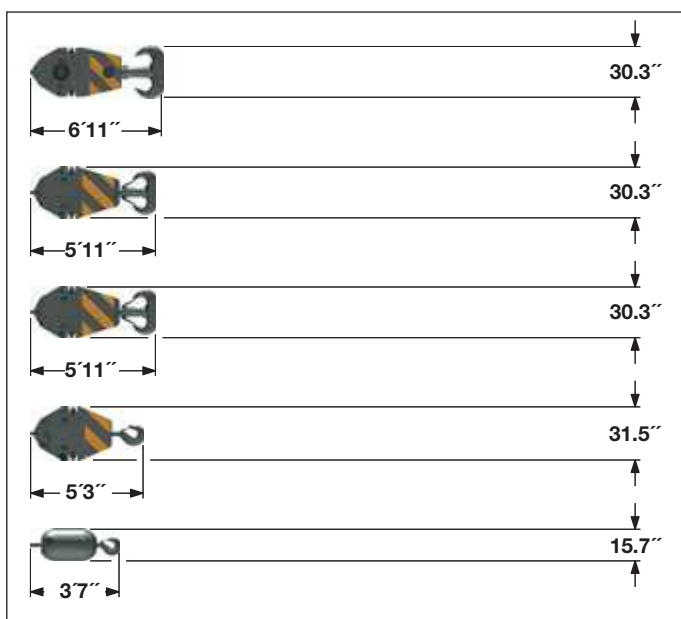

352,800 lbs hook block - 7 sheaves

Width	25.2 inch	29.9 inch	34.6 inch
Weight	3,307 lbs	4,960 lbs	6,614 lbs

220,500 lbs hook block - 5 sheaves

Width	21.3 inch	25.2 inch	27.6 inch
Weight	2,870 lbs	3,970 lbs	5,070 lbs

176,400 lbs hook block - 3 sheaves

Width	14.2 inch	18.1 inch	22.1 inch
Weight	2,205 lbs	3,310 lbs	4,410 lbs

88,200 lbs hook block - 1 sheave

Width	11.8 inch	15.7 inch	19.7 inch
Weight	1,545 lbs	2,425 lbs	3,310 lbs

27,600 lbs single hook

Width	15.7 inch
Weight	1,325 lbs

Technical description



Engine

Power rating according to ISO 9249, 270 kW (362 hp) at 2000 rpm
Engine type _____ Liebherr D 936 A7 SCR
Fuel tank _____ 211 gal capacity with continuous level indicator and reserve warning
Engine complies with NRMM exhaust certification EPA/CARB Tier 4i or 97/68 EC Stage IIIB.



Hydraulic system

A double axial displacement pump supplies the open loop hydraulic system, allowing all functions to be operated simultaneously. To minimize peak pressure an automatic working pressure cut-off is integrated in the pump.
All filters are electronically monitored.
The use of synthetic environmentally friendly (biodegradable) oils is possible.
Working pressure _____ max. 350 bar
Oil tank capacity _____ 650 l



Luffing jib winch

Line pull _____ max. 23,605 lbf
Rope diameter _____ 20 mm
Jib luffing _____ 46 sec. from 15° to 78°



Boom winch

Line pull _____ max. 48,784 lbf
Rope diameter _____ 24 mm
Boom up _____ 119 sec. from 15° to 86°



Swing

Consists of rollerbearing with external teeth, swing drive with fixed axial piston hydraulic motor, spring loaded and hydraulically released multi-disc holding brake, planetary gearbox and pinion.
Both swing modes are possible – speed control or free swing.
A multi-disc holding brake acts automatically at zero swing motion.
Swing speed from 0 – 3 rpm continuously variable.



Main winches

Line pull (1st layer) _____ max. 39,345 lbf
Line pull (7th layer) _____ 29,980 lbf
Rope diameter _____ 26 mm
Drum diameter _____ 22.8 inch
Rope speed _____ 0 – 446 ft/min
Rope capacity in 7 layers _____ 1,604 inch
The winches are outstanding in their compact design and easy assembly. Propulsion is via a planetary gearbox in an oil bath. Load support by the hydraulic system; additional safety factor provided by a spring loaded, multi-disc holding brake.
The main winches use pressure controlled, variable flow hydraulic motors. This system features sensors that automatically adjust oil flow to provide max. winch speed depending on load.
Option – winch with freetail system:
Clutch and braking functions on the freetail system are provided by a compact designed, low wear and maintenance free multi-disc brake.



Crawlers

Propulsion through axial piston motor, hydraulically released spring loaded multi-disc brake, crawler tracks, hydraulic chain tensioning device.
Track pads _____ 39.4 inch
Drive speed _____ 0 – 0.93 mph



Control

The heart of the hydraulic crawler cranes is the Liebherr control system which has been developed and manufactured in-house.
It includes all control and monitoring functions and is designed to withstand extreme environmental conditions and heavy duty construction tasks. Complete machine operating data as well as warning signals and irregularities are clearly displayed on the high resolution monitor in the operator's cab in the required language.
The electro-hydraulic proportional control allows several movements to be performed simultaneously. This ensures that all categories of loads can be positioned with utmost precision.
Option:
• GSM/GPRS telematics module



Noise emission

Noise emissions correspond with 2000/14/EC directive on noise emission by equipment used outdoors.

Boom combinations



Main boom No. 2018.xx — 287 ft

Max. combination — 344 ft

Max. combination — 332 ft

Main boom No. 2018.xx — 206 ft

Main boom No. 2018.xx — 168 ft

Tapered No. 2018/1309.xx — 24 ft

Tapered No. 2018/1713.xx — 39 ft

Luffing jib No. 1309.xx — 114 ft

Luffing jib No. 1713.xx — 125 ft

Boom combinations

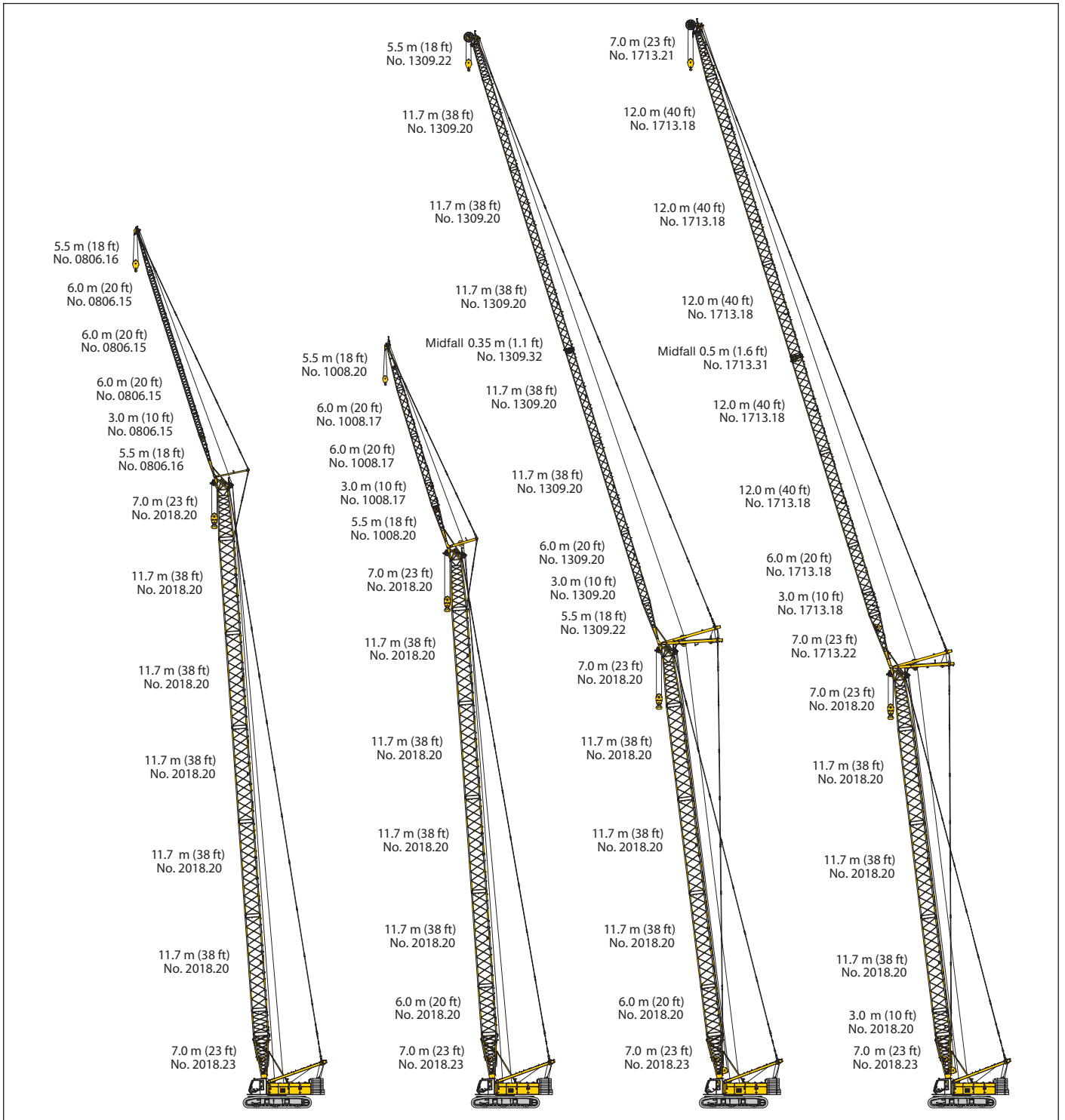

Max. combination	353 ft
Main boom No. 2018.xx	248 ft
Fixed jib No. 0806.xx	105 ft
Main boom No. 2018.xx	258 ft
Fixed jib No. 0806.xx	85 ft

Max. combination	304 ft
Main boom No. 2018.xx	219 ft
Fixed jib No. 1008.xx	85 ft
Main boom No. 2018.xx	229 ft
Fixed jib No. 1008.xx	66 ft

Max. combination	439 ft
Main boom No. 2018.xx	181 ft
Luffing jib No. 1309.xx	258 ft
Main boom No. 2018.xx	191 ft
Luffing jib No. 1309.xx	219 ft

Max. combination	443 ft
Main boom No. 2018.xx	171 ft
Luffing jib No. 1713.xx	272 ft
Main boom No. 2018.xx	191 ft
Luffing jib No. 1713.xx	164 ft

Self assembly system

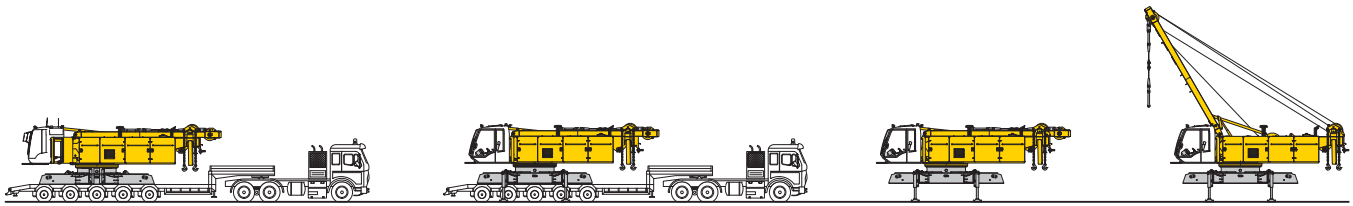

Unloading of basic machine

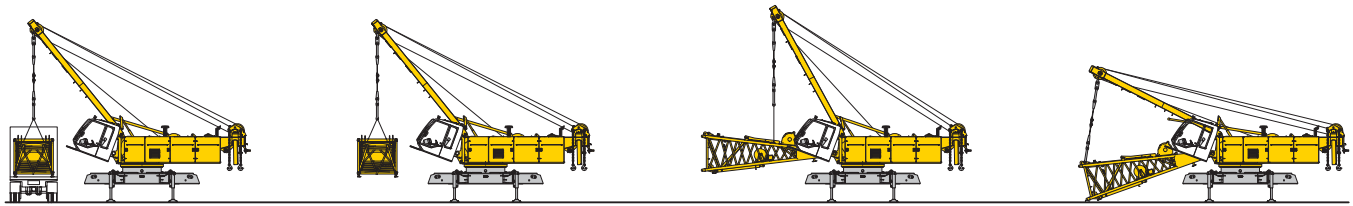

Unloading and assembly of boom foot

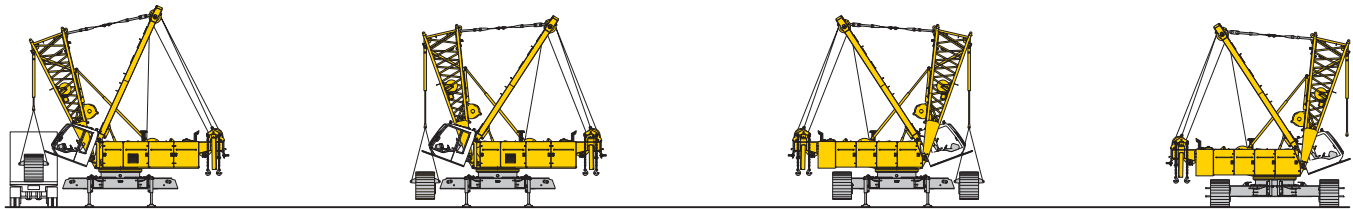

Unloading and assembly of crawlers

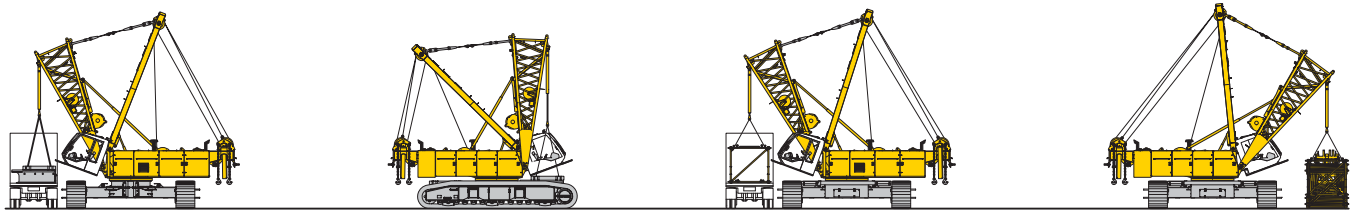

Unloading and assembly of carbody counterweight

Unloading and assembly of boom

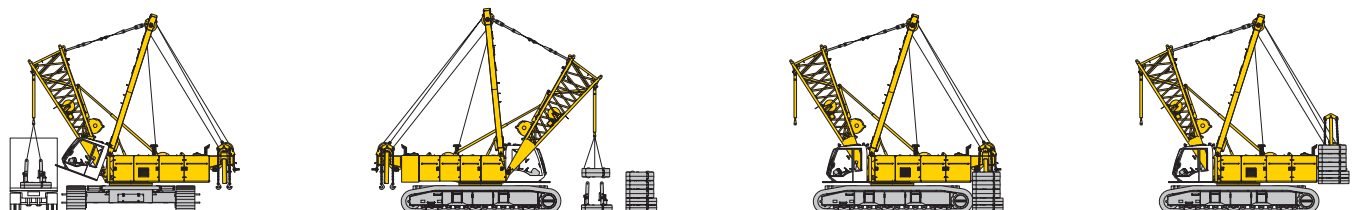

Unloading and assembly of counterweight

Erecting of main boom to working position

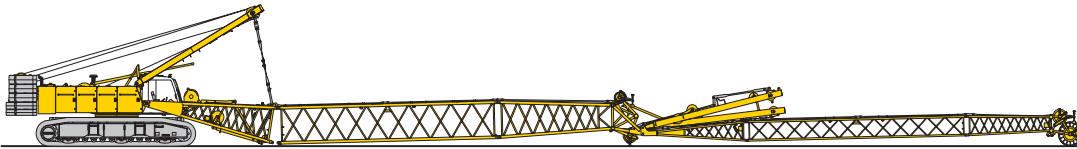

Assembly of boom

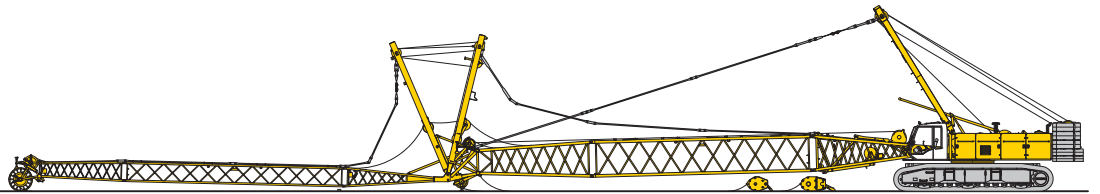

Reeving of hoist and luffing jib ropes



Erecting of main boom and luffing jib

Working position

Working range - main boom (No. 2018.xx) **86° - 15°** **137,400 lbs counterweight and 44,100 lbs carbody counterweight**

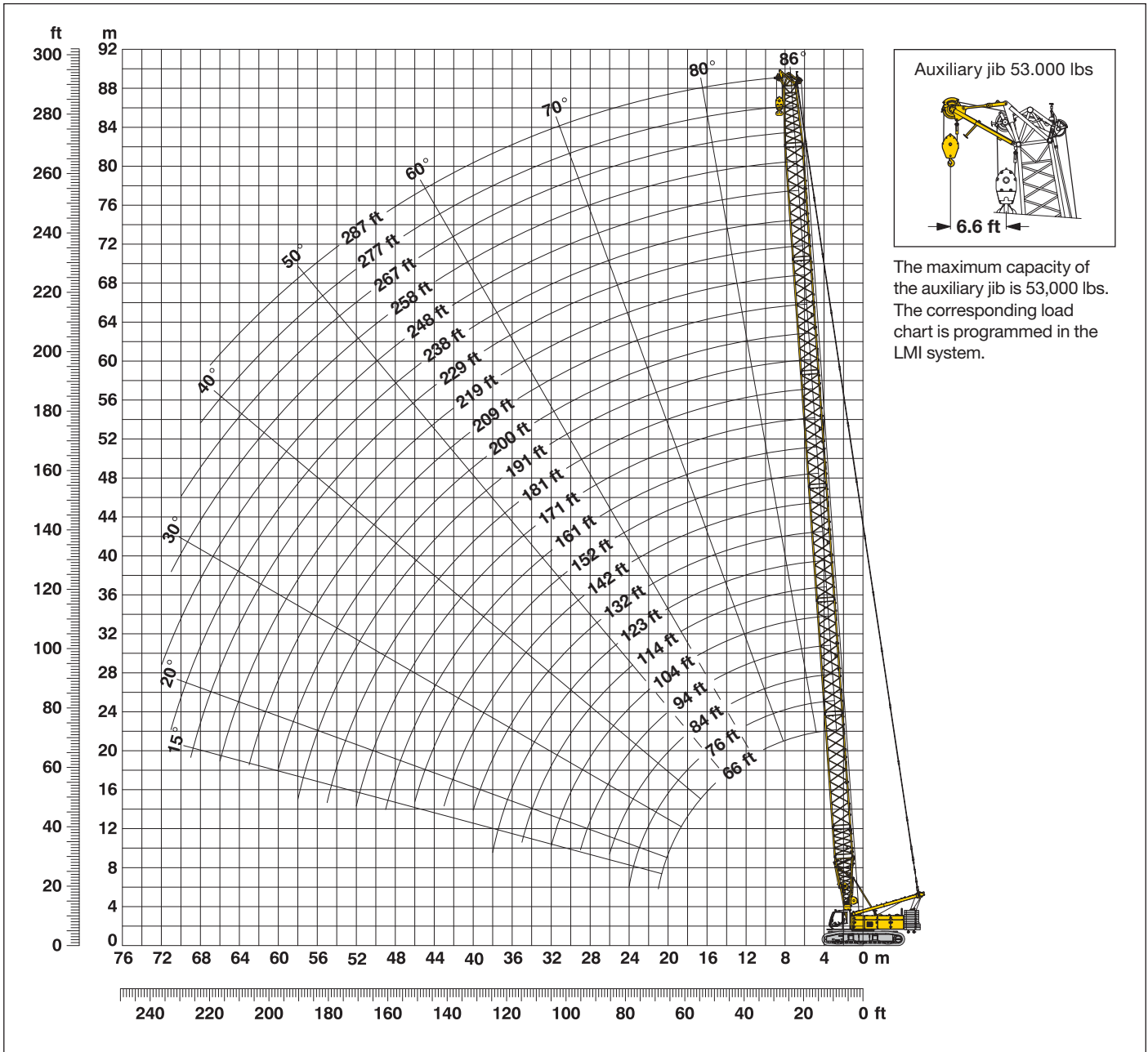

Main boom configuration (Table 1 – No. 2018.xx)

Configuration for boom lengths (66 ft - 287 ft)

	Length*	Amount of boom extensions																							
Boom foot	23 ft	1	1	1	1	1	1	1	1	1	1	1	1	1	1	1	1	1	1	1	1	1			
Boom insert	10 ft		1		1		1		1		1		1		1		1		1		1				
Boom insert	20 ft	1	1			1	1			1	1			1	1			1	1			1			
Boom insert	38 ft			1	1	1	1	2	2	2	2	3	3	3	3	4	4	4	4	5	5	5	5		
Boom head	23 ft	1	1	1	1	1	1	1	1	1	1	1	1	1	1	1	1	1	1	1	1	1			
Boom length (ft)		66	76	84	94	104	114	123	132	142	152	161	171	181	191	200	209	219	229	238	248	258	267	277	287

*Actual lengths of boom sections are metric (e.g. 3 m, 6 m, 7 m, 11.7 m). The figures shown above are approximate conversions to feet.

Lift chart for main boom (No. 2018.xx)

137,400 lbs counterweight and 44,100 lbs carbody counterweight

Capacities in 1000 lbs for boom lengths (66 ft - 287 ft) - with 26,780 lbf winches

Radius	Boom length in (ft)												Radius
	66	94	114	133	152	171	191	209	229	248	267	287	
(ft)	lbs	lbs	lbs	lbs	lbs	lbs	lbs	lbs	lbs	lbs	lbs	lbs	(ft)
14.7		352,7*											14.7
15		302,5											15
20	302,1	294,1	278,0	245,0	205,0								20
25	265,5	258,9	248,9	233,5	196,5	166,7	138,8	110,4	91,5				25
30	200,4	200,6	200,5	199,1	180,3	161,0	134,0	107,1	90,0	76,5	63,2	53,1	30
40	131,7	131,7	131,4	131,2	130,9	130,6	122,3	100,2	85,0	73,4	60,9	51,5	40
50	97,1	97,0	96,7	96,4	96,0	95,7	95,2	92,9	80,4	71,1	58,3	49,3	50
60	76,1	76,2	75,8	75,5	75,1	74,7	74,2	73,7	73,2	67,3	55,6	46,9	60
70	26,6	62,2	61,9	61,5	61,0	60,6	60,1	59,6	59,1	58,6	52,5	44,6	70
80		52,2	51,8	51,5	51,0	50,6	50,0	49,6	49,0	48,5	47,9	42,3	80
90		44,6	44,3	44,0	43,5	43,1	42,5	42,0	41,4	40,9	40,3	39,7	90
95		41,4	41,2	40,9	40,4	39,9	39,4	38,9	38,3	37,8	37,2	36,5	95
100			38,4	38,1	37,6	37,2	36,6	36,1	35,5	35,0	34,4	33,7	100
115			31,5	31,4	30,9	30,5	29,9	29,4	28,8	28,2	27,6	26,9	115
120				29,5	29,0	28,6	28,0	27,5	26,9	26,5	25,9	25,2	120
130				26,3	25,9	25,5	24,9	24,4	23,8	23,2	22,6	22,0	130
140					23,1	22,7	22,1	21,6	21,0	20,5	19,9	19,2	140
150					20,7	20,3	19,8	19,3	18,7	18,1	17,5	16,8	150
160						18,3	17,7	17,2	16,6	16,1	15,4	14,8	160
170						16,4	15,9	15,4	14,8	14,3	13,6	13,0	170
180							14,3	13,8	13,2	12,7	12,1	11,4	180
190							12,8	12,4	11,8	11,3	10,6	10,0	190
200								11,1	10,5	10,0	9,4	8,7	200
205								10,5	9,9	9,4	8,8	8,1	205
210									9,4	8,9	8,2	7,6	210
225									7,8	7,3	6,7	6,0	225
230										6,8	6,2	5,6	230
245										5,5	4,9	4,3	245
250											4,5	3,9	250
265											3,4	2,8	265
270												2,5	270
275												2,1	275

TLT 10576462 - M124400 Offiziell

Above lift chart is for reference only. For actual lift duty please refer to lift chart in operator's cab or manual.

*) Capacities over 308,650 lbs require a special heavy duty boom head.

L-boom high reach (No. 2018/1309.xx) 219 ft - 344 ft

Working range 86° - 15°

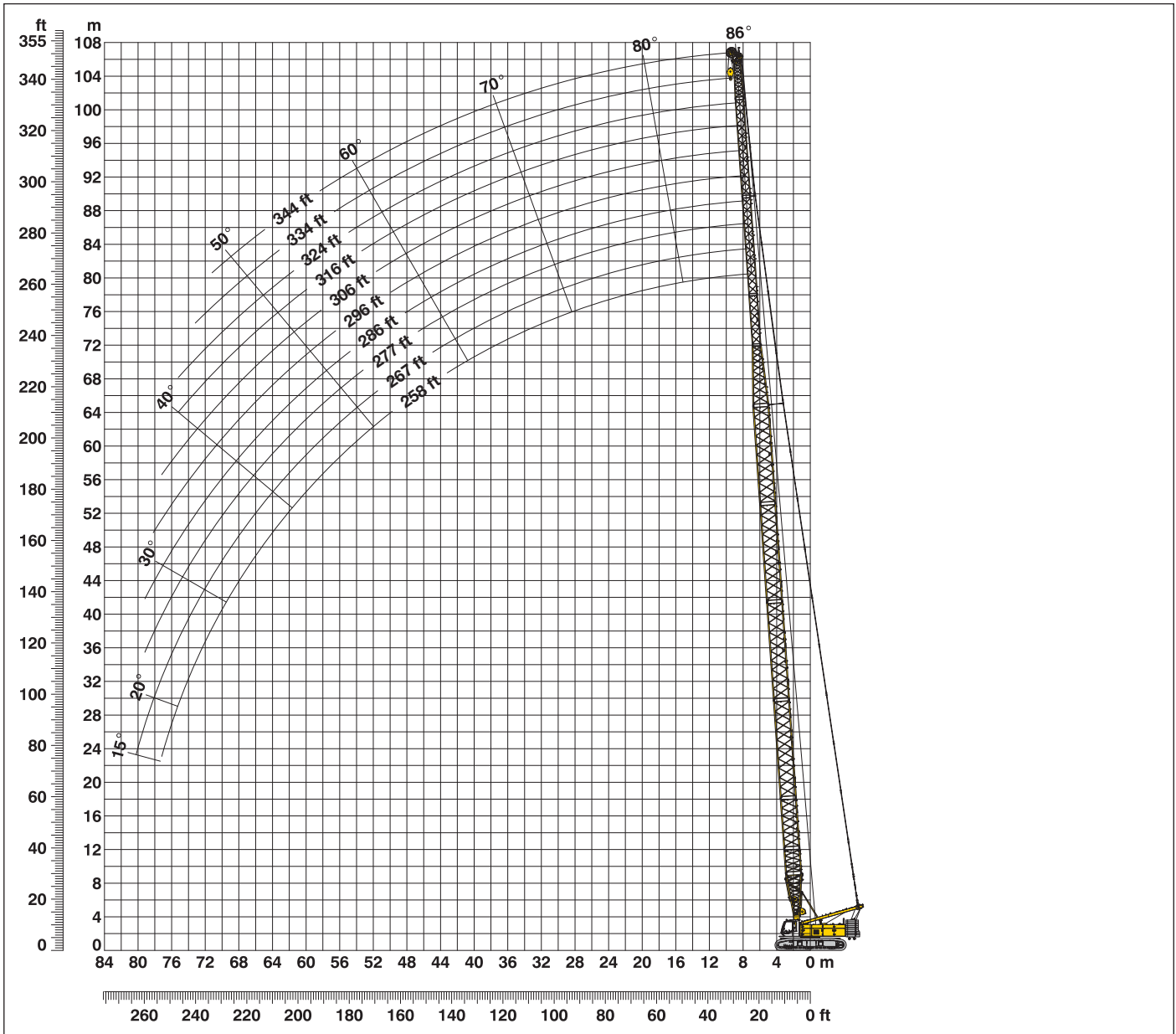

L-boom configuration with 168 ft main boom (No. 2018.xx/1309.xx)

Configuration for L-boom lengths (219 ft - 316 ft)

	Length*	Amount of boom and luffing jib extensions											
		1	1	1	1	1	1	1	1	1	1	1	1
Boom foot	23 ft	1	1	1	1	1	1	1	1	1	1	1	1
Boom insert	10 ft	1	1	1	1	1	1	1	1	1	1	1	1
Boom insert	20 ft	1	1	1	1	1	1	1	1	1	1	1	1
Boom insert	38 ft	3	3	3	3	3	3	3	3	3	3	3	3
Tapered	24 ft	1	1	1	1	1	1	1	1	1	1	1	1
Luffing insert	10 ft	1		1		1		1		1		1	
Luffing insert	20 ft		1	1			1	1			1	1	
Luffing insert	38 ft				1	1	1	1	2	2	2	2	2
Luffing jib head	18 ft	1	1	1	1	1	1	1	1	1	1	1	1
Max. L-boom length (ft)		219	229	239	248	258	267	277	286	296	306	316	

*Actual lengths of boom sections are metric (e.g. 3 m, 6 m, 7 m, 11.7 m). The figures shown above are approximate conversions to feet.

Lift chart for L-boom (No. 2018/1309.xx)

Main boom length 168 ft

Capacities in 1000 lbs
137,400 lbs counterweight and 44,100 lbs carbody counterweight

Radius	Boom length in (ft)				
	219	258	277	296	316
(ft)	lbs	lbs	lbs	lbs	lbs
22	99,5				
25	99,3	59,0			
30	97,4	57,8	43,6	33,8	24,9
40	93,6	52,7	39,2	30,9	22,3
50	80,3	47,9	35,4	27,8	20,0
60	65,4	43,9	32,1	25,1	18,1
70	53,9	40,4	29,2	22,9	16,6
80	48,2	37,3	27,0	20,9	15,2
90	42,6	34,4	24,8	19,1	14,1
100	37,9	31,7	22,9	17,5	13,0
110	33,2	29,1	20,9	16,1	12,0
120	29,4	27,2	19,5	14,7	11,0
130	26,1	25,2	18,4	13,8	10,0
140	23,5	23,3	17,3	13,0	9,5
150	21,2	21,0	16,4	12,2	9,0
160	19,1	18,9	15,7	11,5	8,5
170	17,3	17,1	14,9	11,0	8,2
180	15,8	15,6	14,1	10,4	7,8
190	14,3	14,2	13,0	9,8	7,5
200	13,1	12,7	12,0	9,4	7,2
210	11,9	11,6	11,0	8,9	6,9
215	11,2	11,0	10,4	8,7	6,7
240		8,2	8,0	7,4	6,0
255		6,6	6,5	6,2	5,3
260			6,2	5,8	5,0
270			5,3	5,1	4,4
280				4,4	3,7
290				3,6	3,2
300					2,6
305					2,3

TLT 10576462 - M124400 Offiziell

Main boom length 206 ft

Capcities in 1000 lbs
137,400 lbs counterweight and 44,100 lbs carbody counterweight

Radius	Boom length in (ft)				
	258	277	296	316	344
(ft)	lbs	lbs	lbs	lbs	lbs
24,7	70,0				
25	70,0				
30	69,4	58,2	47,1	36,1	
35	68,3	57,3	45,9	35,5	26,4
40	67,1	56,4	44,3	34,0	25,6
50	64,3	53,7	41,2	31,1	23,7
60	57,7	50,8	38,4	28,5	22,0
80	43,2	42,0	33,7	24,2	19,2
90	38,6	36,7	31,6	22,7	18,0
100	34,6	33,3	29,6	21,0	16,9
110	30,9	29,9	27,7	19,6	15,9
120	27,7	26,9	25,8	18,3	14,9
130	24,4	24,2	23,7	16,9	13,9
140	22,2	21,7	21,5	16,1	12,8
150	20,0	19,8	19,3	15,4	12,3
160	17,9	17,8	17,3	14,6	11,7
170	16,1	15,8	15,6	13,7	11,2
180	14,6	13,9	13,9	12,5	10,6
190	13,0	12,6	12,1	11,4	9,8
200	11,3	11,3	10,9	10,3	8,9
210	10,3	9,9	9,8	9,2	8,0
220	9,2	8,7	8,5	8,2	7,1
230	7,9	7,8	7,3	7,2	6,2
240	7,0	6,8	6,5	6,0	5,3
250	6,0	5,7	5,7	5,2	4,4
255	5,4	5,3	5,2	4,8	3,9
270		3,8	3,9	3,6	2,8
285			2,8	2,5	2,2
290			2,3	2,3	
295				2,0	

TLT 10576462 - M124400 Offiziell

Above lift chart is for reference only. For actual lift duty please refer to lift chart in operator's cab or manual.

L-boom configuration with 206 ft main boom (No. 2018.xx/1309.xx)

Configuration for L-boom lengths (257 ft - 344 ft)

	Length*	Amount of boom and luffing jib extensions									
		1	1	1	1	1	1	1	1	1	1
Boom foot	23 ft	1	1	1	1	1	1	1	1	1	1
Boom insert	10 ft	1	1	1	1	1	1	1	1	1	1
Boom insert	20 ft	1	1	1	1	1	1	1	1	1	1
Boom insert	38 ft	4	4	4	4	4	4	4	4	4	4
Tapered	24 ft	1	1	1	1	1	1	1	1	1	1
Luffing insert	10 ft	1		1		1		1		1	
Luffing insert	20 ft		1	1			1	1			1
Luffing insert	38 ft				1	1	1	1	2	2	2
Luffing jib head	18 ft	1	1	1	1	1	1	1	1	1	1
Max. L-boom length (ft)		258	267	277	286	296	306	316	324	334	344

*Actual lengths of boom sections are metric (e.g. 3 m, 6 m, 7 m, 11.7 m). The figures shown above are approximate conversions to feet.

L-boom high reach (No. 2018/1713.xx) **243 ft - 332 ft**

Working range 86° - 15°

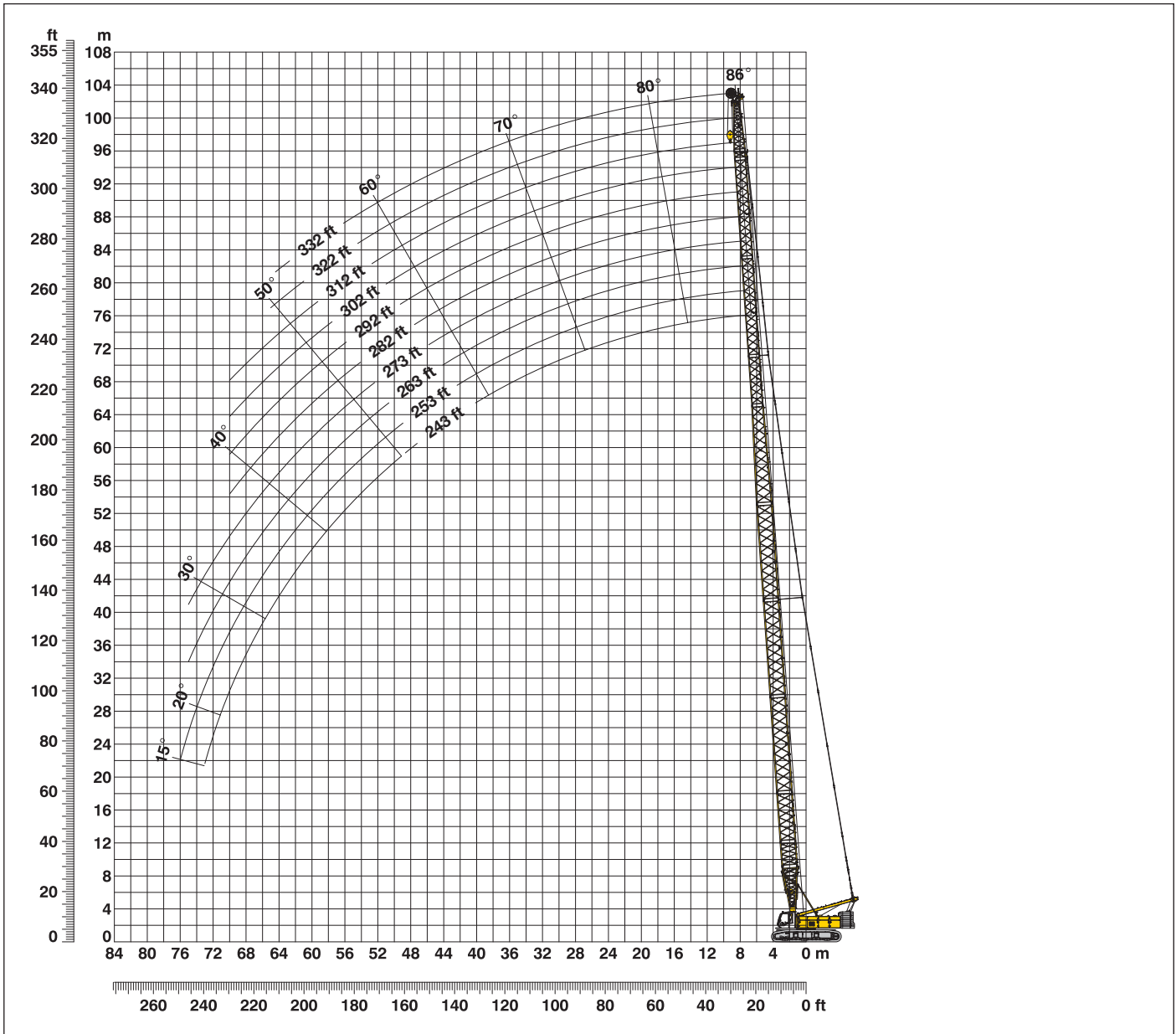

L-boom configuration with 168 ft main boom (No. 2018.xx/1713.xx)

Configuration for L-boom lengths (243 ft - 332 ft)

	Length*	Amount of boom and luffing jib extensions										
		1	1	1	1	1	1	1	1	1	1	
Boom foot	23 ft	1	1	1	1	1	1	1	1	1	1	1
Boom insert	10 ft	1	1	1	1	1	1	1	1	1	1	1
Boom insert	20 ft	1	1	1	1	1	1	1	1	1	1	1
Boom insert	38 ft	3	3	3	3	3	3	3	3	3	3	3
Tapered	40 ft	1	1	1	1	1	1	1	1	1	1	1
Luffing insert	10 ft			1		1		1		1		1
Luffing insert	20 ft		1	1		1		1		1		1
Luffing insert	40 ft				1	1	1	1	2	2		2
Luffing insert	3 ft	1	1	1	1	1	1	1	1	1	1	1
Luffing jib head	23 ft	1	1	1	1	1	1	1	1	1	1	1
Max. L-boom length (ft)		243	253	263	273	282	292	302	312	322	332	332

*Actual lengths of boom sections are metric (e.g. 1 m, 3 m, 6 m, 7 m, 11.7 m, 12 m). The figures shown above are approximate conversions to feet.

Lift chart for L-boom (No. 2018/1713.xx)

Main boom length 168 ft

Capacities in 1000 lbs for boom lengths (243 ft - 332 ft) - with 26,980 lbf winches
137,400 lbs counterweight and 44,100 lbs carbody counterweight

Radius	Boom length in (ft)										Radius	
	243	253	263	273	282	292	302	312	322	332		
(ft)	lbs	lbs	lbs	lbs	lbs	lbs	lbs	lbs	lbs	lbs	lbs	(ft)
23,7	81,5											23,7
25	81,5	73,5										25
30	80,8	72,9	66,6	60,8	53,0	49,8	45,4	40,7	36,9			30
35	79,8	71,9	65,9	59,9	53,0	49,0	44,5	40,2	36,6	32,9		35
40	78,6	70,9	65,3	59,0	53,0	47,8	43,5	39,3	35,9	32,2		40
50	74,2	68,3	62,8	56,6	50,7	45,6	41,7	37,6	34,1	30,7		50
60	62,6	59,4	57,5	53,9	47,8	43,2	39,5	35,6	32,5	29,3		60
80	45,0	43,9	43,7	43,6	40,6	37,7	34,9	31,4	28,4	25,6		80
100	35,9	34,2	34,5	33,9	32,9	32,0	30,9	28,2	25,7	23,7		100
110	32,1	30,4	30,8	30,4	29,6	29,0	28,1	26,3	24,3	22,7		110
120	28,3	27,6	27,7	27,4	26,6	26,5	25,4	24,4	22,9	21,7		120
130	25,2	24,9	24,6	24,5	24,0	24,2	23,5	22,9	21,5	20,6		130
140	22,4	22,4	22,1	22,0	21,6	21,6	21,2	20,7	19,6	19,2		140
150	20,1	20,0	19,8	19,8	19,4	19,0	18,7	18,5	17,6	17,2		150
160	18,0	18,0	17,7	17,8	17,5	17,0	16,4	16,3	15,7	15,2		160
170	16,3	16,2	15,8	16,0	15,6	15,3	14,8	14,5	13,9	13,4		170
180	14,7	14,6	14,4	14,2	13,7	13,5	13,1	12,9	12,5	12,0		180
190	13,2	13,2	12,9	12,8	12,2	11,7	11,4	11,3	11,0	10,7		190
200	12,0	11,6	11,3	11,4	11,0	10,6	10,0	9,7	9,5	9,3		200
210	10,7	10,5	10,0	9,9	9,6	9,4	8,9	8,6	8,1	7,9		210
220	9,2	9,3	8,9	8,9	8,3	8,1	7,7	7,6	7,2	6,8		220
230	8,2	8,0	7,8	7,9	7,4	7,0	6,6	6,6	6,2	5,9		230
240	7,0	7,1	6,7	6,8	6,5	6,2	5,6	5,5	5,2	5,0		240
250		6,0	5,8	5,8	5,5	5,3	4,9	4,8	4,2	4,0		250
260			4,7	5,1	4,6	4,4	4,0	4,0	3,5	3,2		260
265				4,6	4,3	3,9	3,6	3,6	3,2	3,0		265
275					3,4	3,3	2,8	2,8	2,5	2,4		275
280						2,9	2,5	2,4	2,1	2,2		280
285						2,5	2,2	2,2				285
290								2,0				290

TLT 10576462 - M124400 Offiziell

Above lift chart is for reference only. For actual lift duty please refer to lift chart in operator's cab or manual.

Working range - luffing jib (No. 1309.xx) 78° - 15°

Main boom 88° - 45°

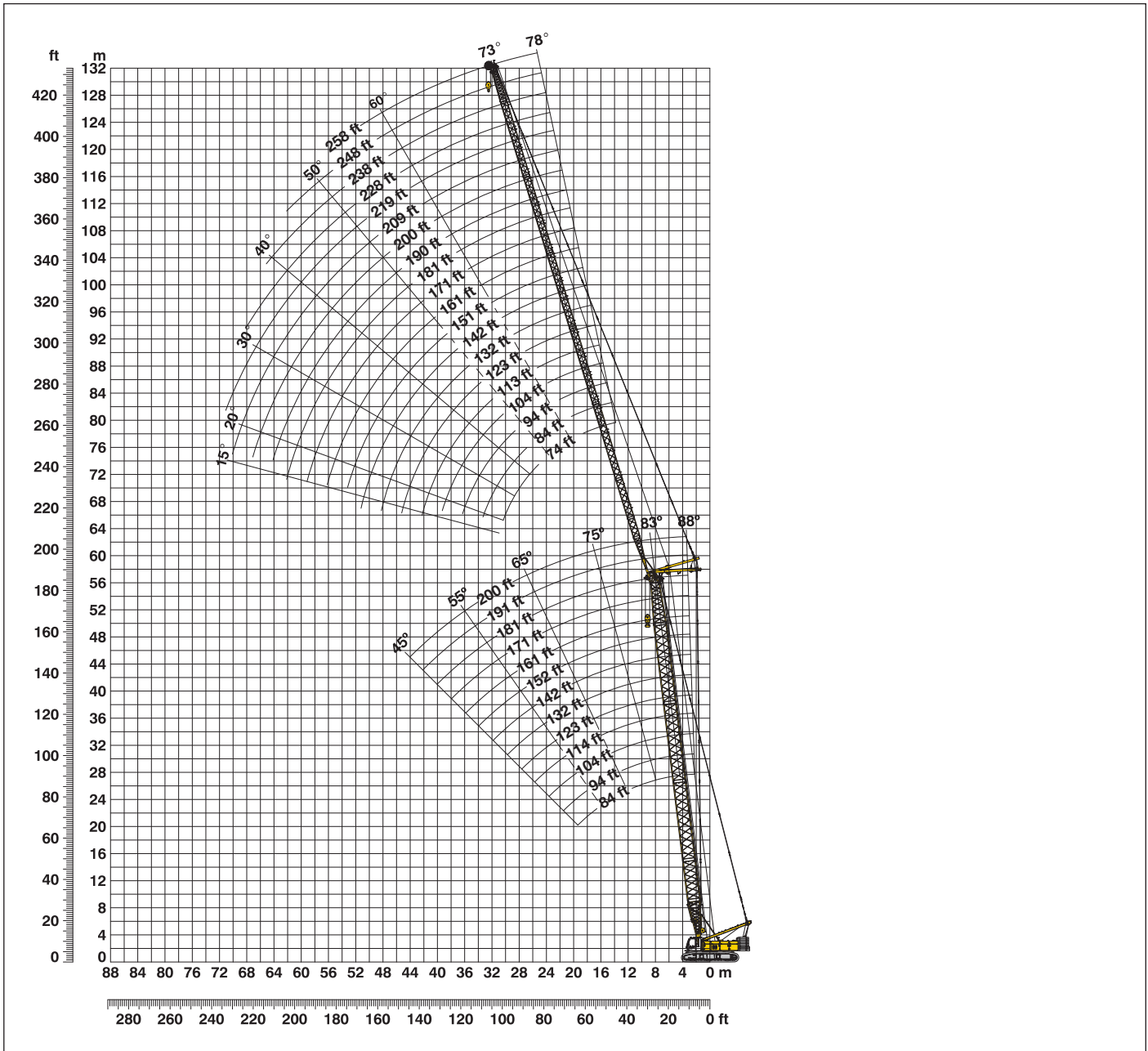

Boom configuration for main boom lengths (84 ft - 200 ft) - see table 1 on page 12 Jib configuration for jib lengths (74 ft - 258 ft)

	Length*	Amount of luffing jib extensions																			
		74	84	94	104	113	123	132	142	151	161	171	181	190	200	209	219	228	238	248	258
Luffing jib foot	18 ft	1	1	1	1	1	1	1	1	1	1	1	1	1	1	1	1	1	1	1	1
Luffing jib insert	10 ft		1		1		1		1		1		1		1		1		1		1
Luffing jib insert	20 ft			1	1		1		1		1		1		1		1		1		1
Luffing jib insert	38 ft	1	1	1	1	2	2	2	2	3	3	3	3	4	4	4	4	5	5	5	5
Luffing jib head	18 ft	1	1	1	1	1	1	1	1	1	1	1	1	1	1	1	1	1	1	1	1
Luffing jib length (ft)		74	84	94	104	113	123	132	142	151	161	171	181	190	200	209	219	228	238	248	258

*Actual lengths of boom sections are metric (e.g. 3 m, 6 m, 11.7 m). The figures shown above are approximate conversions to feet.

Lift chart - luffing jib (No. 1309.xx)

Main boom 88°

Main boom 84 ft

Radius	Jib length in (ft)							
	74	94	113	133	161	181	228	258
(ft)	lbs	lbs	lbs	lbs	lbs	lbs	lbs	lbs
28,1	104,8							
35	104,8	90,5						
40	103,0	88,5	70,7					
45	93,1	86,8	69,4	55,7				
50	84,2	79,5	68,0	54,7	38,0			
55	73,9	71,9	65,5	53,5	36,9	29,3		
65	61,3	59,6	57,8	49,7	34,9	27,7	15,8	
70	55,8	54,2	53,4	47,4	34,2	27,0	15,3	10,4
80	46,6	46,6	44,9	42,7	32,4	25,7	14,6	9,7
100		34,7	34,6	33,4	28,6	23,5	13,4	8,5
120			26,9	26,9	24,8	21,4	12,4	7,5
140				22,0	21,0	19,1	11,6	6,8
165					17,1	16,2	10,9	6,1
185						13,3	10,5	5,7
230							8,1	5,0
260								4,3

Main boom 123 ft

Radius	Jib length in (ft)							
	74	94	113	133	161	181	228	258
(ft)	lbs	lbs	lbs	lbs	lbs	lbs	lbs	lbs
29,5	100,4							
35	100,0	78,9						
40	95,4	77,4	62,9					
45	88,6	76,0	61,8	49,3				
50	83,1	73,9	60,7	48,3	34,9			
55	74,9	70,6	59,8	47,5	34,1	27,3		
65	63,5	61,2	57,3	45,2	32,5	26,0	14,5	
70	57,7	55,7	55,2	43,3	31,9	25,4	14,3	9,8
85	26,6	44,6	43,4	38,0	29,8	23,8	13,4	9,0
100		36,2	35,6	33,3	27,8	22,5	12,7	8,2
120			28,0	27,3	25,0	20,8	11,9	7,3
140				17,6	21,4	18,9	11,2	6,6
165					17,1	16,4	10,5	5,9
185						13,8	10,1	5,5
230							8,1	4,9
260								4,6

Main boom 142 ft

Radius	Jib length in (ft)							
	74	94	113	133	161	181	228	258
(ft)	lbs	lbs	lbs	lbs	lbs	lbs	lbs	lbs
30,2	88,3							
35	87,9	70,8						
40	83,3	69,5	56,8					
45	78,0	67,6	56,2	44,8				
50	73,4	65,6	55,0	43,7	32,3			
55	68,8	62,2	54,0	42,9	31,8	26,0		
65	61,2	56,5	50,9	41,5	30,5	25,0	13,8	
70	57,2	53,7	49,6	40,5	30,1	24,4	13,6	9,5
85	44,8	44,5	43,4	36,9	28,3	22,9	12,9	8,7
105		22,6	33,8	31,2	26,2	21,3	12,1	7,8
120			28,3	27,1	24,7	20,1	11,5	7,2
140				22,2	21,0	18,4	10,8	6,5
170					13,6	15,5	10,1	5,7
185						13,8	9,7	5,4
230							8,1	4,8
260								4,5

Main boom 181 ft

Radius	Jib length in (ft)							
	74	94	113	133	161	181	228	258
(ft)	lbs	lbs	lbs	lbs	lbs	lbs	lbs	lbs
31,5	64,1							
40	61,5	51,5	43,4					
45	59,2	50,3	42,9	35,7				
50	56,4	49,3	41,9	35,3	27,0			
55	53,5	47,4	40,8	34,7	26,8	22,3		
65	48,6	44,0	38,6	33,1	25,9	21,8	12,2	
70	46,4	42,1	37,8	32,2	25,4	21,4	12,0	7,9
80	43,3	39,1	35,5	31,0	24,4	20,7	11,6	7,5
100		31,4	27,9	28,0	22,7	19,4	11,0	6,5
105		17,5	25,8	27,4	22,2	19,1	10,8	6,2
120			23,2	25,4	21,0	18,1	10,4	5,9
140				19,8	16,9	16,2	9,8	5,7
170					9,6	13,0	9,0	5,0
190						9,3	8,6	4,7
235							5,5	4,1
260								4,0

Main boom 191 ft

Radius	Jib length in (ft)						
	74	94	113	133	161	181	219
(ft)	lbs	lbs	lbs	lbs	lbs	lbs	lbs
31,9	58,9						
40	56,4	48,3	40,9				
45	54,5	46,9	40,3	33,8			
50	52,4	45,7	39,4	33,3	25,6		
55	50,0	44,2	38,4	32,7	25,4	21,2	
65	45,6	41,3	36,3	31,3	24,5	20,7	11,8
70	43,5	39,7	35,5	30,5	24,1	20,4	11,5
80	40,6	37,0	33,4	29,3	23,2	19,8	11,0
85	39,5	35,6	32,6	28,4	22,7	19,4	10,8
100		32,7	29,8	26,5	21,4	18,5	10,1
105		31,9	28,9	25,8	20,9	18,2	9,9
120			27,1	24,0	19,8	17,1	9,5
140				21,5	18,3	16,0	8,9
170					11,7	14,4	8,2
190						10,0	7,7
225							7,2

Main boom 200 ft

Radius	Jib length in (ft)				
	74	94	113	133	161
(ft)	lbs	lbs	lbs	lbs	lbs
32,2	54,1				
40	52,7	44,6			
45	50,9	43,2	37,4	28,2	
55	47,1	40,9	35,7	26,5	20,8
60	44,8	40,1	34,9	25,9	20,2
70	41,1	37,2	33,1	24,6	19,2
80	38,4	34,7	31,2	23,4	18,4
85	37,5	33,4	30,4	22,8	18,0
100		28,0	27,9	21,4	17,0
105		25,2	27,2	20,8	16,6
110			26,2	20,2	16,3
125			14,1	18,8	15,3
130				18,5	14,9
140				17,7	14,3
150					13,7
170					10,3

TLT 10576462 - M124400 Offiziell

Capacities in 1000 lbs with luffing jib (No. 1309.xx), 137,400 lbs counterweight + 44,100 lbs carbody counterweight. Above lift chart is for reference only. For actual lift duty and complete chart with all available configurations please refer to lift chart in operator's cab or manual.

Lift chart - luffing jib (No. 1309.xx)

Main boom 83°

Main boom 84 ft

Radius (ft)	Jib length in (ft)							
	74	94	113	133	161	181	228	258
41,9	104,9							
50	100,3	87,6						
55	89,1	85,8	68,5					
60	78,9	76,8	67,6	54,1				
70	64,5	62,8	59,9	51,9	35,5			
75	58,6	56,7	56,0	49,2	34,5	27,3		
90	45,3	44,8	44,0	41,4	32,0	25,4	14,6	
100		39,4	38,3	36,5	30,5	24,2	13,9	8,9
110		26,6	33,8	32,6	28,3	23,3	13,3	8,4
120			30,0	29,1	26,6	22,3	12,8	7,9
125			28,1	27,6	25,5	21,9	12,6	7,7
145				22,3	21,5	19,6	11,8	6,9
175					16,9	16,0	10,9	6,0
190						13,9	10,5	5,7
240							8,0	5,0
265								4,7

Main boom 123 ft

Radius (ft)	Jib length in (ft)							
	74	94	113	133	161	181	228	258
46,6	97,4							
55	87,8	76,6						
60	78,7	75,2	61,1					
65	71,3	70,9	60,1	47,8				
75	59,9	59,5	57,4	46,3	32,7			
80	55,4	55,0	54,6	44,2	32,0	25,4		
95	44,9	44,7	44,1	38,9	30,0	23,9	13,5	
105		39,5	38,5	35,6	28,8	22,9	13,1	8,5
110		26,6	36,9	36,1	34,1	28,0	22,5	12,9
115			26,6	34,0	32,3	27,3	22,1	12,6
130				28,4	27,8	25,3	20,9	12,0
150					22,5	21,6	19,1	11,2
180						15,3	16,0	10,5
195							14,1	10,2
240								8,2
270								4,7

Main boom 142 ft

Radius (ft)	Jib length in (ft)							
	74	94	113	133	161	181	228	258
49	83,9							
55	80,3	69,3						
65	70,7	65,1	55,6					
70	64,5	62,7	54,8	44,0				
75	59,3	58,9	53,4	43,2	30,8			
85	51,0	50,6	49,8	40,9	30,0	24,1		
95	44,5	44,2	43,9	38,3	28,9	23,2	13,0	
105		39,2	38,9	35,2	28,0	22,3	12,6	8,3
110		37,0	36,7	34,1	27,4	21,9	12,4	8,1
115		35,0	34,8	32,5	26,8	21,6	12,2	7,9
135			18,9	27,2	24,4	20,1	11,4	7,1
155				16,2	21,2	18,4	10,8	6,5
180					17,0	16,2	10,2	5,8
200						11,4	9,8	5,4
245							8,0	4,8
275								4,4

Main boom 181 ft

Radius (ft)	Jib length in (ft)							
	74	94	113	133	161	181	228	258
53,7	60,1							
60	58,0	50,5						
65	55,2	49,4	42,3					
75	50,3	45,8	41,0	34,8				
80	48,5	44,1	39,6	34,3	26,1			
85	46,6	42,4	38,5	33,6	25,9	21,2		
100	40,9	38,5	35,1	31,2	24,7	20,4	11,5	
110		36,0	32,8	29,6	24,1	19,8	11,2	6,9
120		31,3	30,5	28,3	23,0	19,3	11,0	6,6
130			28,0	26,9	22,2	18,7	10,6	6,5
140			15,0	25,7	21,1	18,2	10,3	6,2
155				21,6	19,0	16,9	9,9	5,9
185					16,0	14,2	9,2	5,2
205						10,8	8,9	4,8
250							6,4	4,1
280								3,7

Main boom 191 ft

Radius (ft)	Jib length in (ft)						
	74	94	113	133	161	181	219
54,9	54,8						
65	50,8	45,2					
70	48,8	43,5	39,1				
75	46,5	41,9	37,8	32,5			
85	43,2	38,9	35,5	31,2	24,5		
90	41,8	37,7	34,4	30,2	24,1	20,0	
100	39,4	35,3	32,3	28,7	23,2	19,5	11,3
120		31,7	29,1	26,0	21,5	18,4	10,4
140			15,7	23,8	20,0	17,3	9,9
160				13,7	18,6	16,2	9,3
180					17,1	15,1	8,9
185					16,7	14,8	8,8
200						13,7	8,5
205						13,4	8,4
220							8,2
240							8,0

Main boom 200 ft

Radius (ft)	Jib length in (ft)				
	74	94	113	133	161
55,9	50,5				
65	47,3	42,1			
70	45,6	40,8	36,3		
75	43,3	39,2	35,1	27,1	
85	40,2	36,4	32,9	25,9	20,3
90	38,8	35,2	32,0	25,3	19,7
100	36,7	33,1	30,0	24,3	19,0
105	21,7	32,1	29,3	23,6	18,7
110		31,3	28,5	23,0	18,4
120		28,8	27,0	22,1	17,7
130			25,6	21,0	17,2
140			23,7	20,2	16,6
150				19,4	16,0
160				16,8	15,5
180					14,5
185					14,2

TLT 10576462 - M124400 Offiziell

Capacities in 1000 lbs with luffing jib (No. 1309.xx), 137,400 lbs counterweight + 44,100 lbs carbody counterweight. Above lift chart is for reference only. For actual lift duty and complete chart with all available configurations please refer to lift chart in operator's cab or manual.

Lift chart - luffing jib (No. 1309.xx)

Main boom 75°

Main boom 84 ft

Radius	Jib length in (ft)							
	74	94	113	133	161	181	228	258
(ft)	lbs	lbs	lbs	lbs	lbs	lbs	lbs	lbs
65	69,3							
75	58,2	57,8						
80	53,8	53,4	53,0					
90	46,7	46,3	45,9	45,5				
100	41,1	40,8	40,4	39,9	31,6			
110		36,3	36,0	35,5	30,5	24,2		
120		32,6	32,3	31,9	28,7	23,2		
130			29,3	28,9	26,5	22,2	12,7	
140			26,6	26,3	25,5	21,3	12,3	
150				24,0	23,2	20,4	12,0	7,1
155				22,8	22,3	19,7	11,7	6,9
160					21,4	19,0	11,5	6,7
185					17,4	16,1	10,8	6,0
205						13,7	10,4	5,6
250							8,1	5,0
280								4,6

Main boom 123 ft

Radius	Jib length in (ft)								
	74	94	113	133	161	181	228	258	
(ft)	lbs	lbs	lbs	lbs	lbs	lbs	lbs	lbs	
73,1	53,0								
85	48,0	47,5							
90	44,8	44,3	43,8						
100	39,4	39,0	38,6	38,0					
110	35,1	34,7	34,3	33,8	29,4				
120		31,2	30,8	30,4	28,7	22,6			
130			28,2	27,9	27,5	26,8	22,0		
140				25,5	25,1	24,4	21,4	11,5	
150				23,3	23,0	22,3	20,7	11,1	
155					22,0	21,4	20,4	11,0	7,0
165					20,3	19,7	19,2	10,7	6,6
180						17,5	17,0	10,4	6,2
195						15,6	15,2	10,1	5,8
215							13,2	9,8	5,4
260								8,0	4,9
290									4,6

Main boom 142 ft

Radius	Jib length in (ft)							
	74	94	113	133	161	181	228	258
(ft)	lbs	lbs	lbs	lbs	lbs	lbs	lbs	lbs
78,2	51,7							
90	43,6	43,1						
95	40,8	40,3	39,9					
105	36,2	35,7	35,3	34,8				
115	32,3	32,0	31,6	31,0	27,9			
125		28,9	28,5	28,0	27,2	21,6		
135		26,2	25,9	25,4	24,7	21,1		
145			23,7	23,2	22,6	20,6	11,4	
155			21,7	21,3	20,7	19,9	11,3	
160				20,5	19,8	19,3	11,1	6,8
170				18,9	18,3	17,8	10,8	6,5
180					16,9	16,4	10,5	6,2
200					14,5	14,1	10,1	5,7
220						12,2	9,7	5,3
265							7,1	4,8
295								4,5

Main boom 181 ft

Radius	Jib length in (ft)								
	74	94	113	133	161	181	228	258	
(ft)	lbs	lbs	lbs	lbs	lbs	lbs	lbs	lbs	
88,1	42,1								
100	36,1	35,6							
105	34,0	33,5	33,0						
115	30,5	30,0	29,5	28,9					
125	27,4	27,0	26,6	26,1	22,7				
135		24,6	24,1	23,7	22,3	18,7			
145		22,4	22,1	21,6	20,9	18,4			
155			20,3	19,8	19,1	17,9	10,1		
165			18,6	18,2	17,5	17,0	10,0		
170				17,5	16,8	16,3	9,9	6,1	
180				16,2	15,6	15,1	9,7	5,8	
200					13,4	12,9	9,3	5,4	
210						12,4	12,0	9,2	5,2
230							10,4	9,0	4,9
275								6,6	4,4
305									4,1

Main boom 191 ft

Radius	Jib length in (ft)						
	74	94	113	133	161	181	219
(ft)	lbs	lbs	lbs	lbs	lbs	lbs	lbs
90,7	39,9						
100	35,5	34,9					
110	31,6	31,0	30,6				
120	28,4	27,9	27,4	26,1			
130	25,6	25,2	24,8	24,3	20,4		
140		23,0	22,6	22,1	19,9	17,1	
150		20,9	20,7	20,2	19,0	16,6	
155			19,8	19,3	18,6	16,3	10,3
165			18,2	17,8	17,1	15,8	10,1
180				15,8	15,1	14,6	9,7
185				15,2	14,5	14,1	9,6
200					13,0	12,6	9,3
210					12,1	11,7	9,0
220						10,8	8,7
230						10,1	8,5
270							6,8

Main boom 200 ft

Radius	Jib length in (ft)				
	74	94	113	133	161
(ft)	lbs	lbs	lbs	lbs	lbs
93	37,9				
105	32,9	32,1			
110	31,1	30,5	28,1		
120	27,9	27,4	26,7	21,6	
130	25,2	24,8	24,4	20,8	17,0
140		22,6	22,2	19,7	16,6
150		20,6	20,3	18,8	15,9
155			19,4	18,3	15,6
160			18,6	17,9	15,2
170			15,7	16,8	14,6
175				16,1	14,3
180				15,5	14,0
185				14,9	13,7
200					12,7
210					11,8
215					11,4

TLT 10576462 - M124400 Offiziel

Capacities in 1000 lbs with luffing jib (No. 1309.xx), 137,400 lbs counterweight + 44,100 lbs carbody counterweight. Above lift chart is for reference only. For actual lift duty and complete chart with all available configurations please refer to lift chart in operator's cab or manual.

Lift chart - luffing jib (No. 1309.xx)

Main boom 65°

Main boom 84 ft

Radius (ft)	Jib length in (ft)							
	74	94	113	133	161	181	228	258
88	45,4							
100	38,9	38,5						
110	34,7	34,3	33,8					
115	32,8	32,4	32,0					
125		29,3	28,9	28,4				
135		26,6	26,3	25,8				
140			25,1	24,7	24,0			
145			24,0	23,6	22,9			
155				21,7	21,0	20,5		
170				19,2	18,6	18,1		
180					17,2	16,7	11,1	
195					15,4	14,9	10,7	6,0
210						13,4	10,4	5,6
220						12,5	10,2	5,4
265							8,2	4,9
290								4,9

Main boom 123 ft

Radius (ft)	Jib length in (ft)							
	74	94	113	133	161	181	228	258
104,2	34,2							
120	28,8	28,3						
130	26,1	25,6	25,2					
140		23,4	22,9	22,4				
150		21,4	21,0	20,5				
155			20,1	19,6	18,8			
170			17,8	17,4	16,7	16,1		
185				15,5	14,8	14,3		
195					13,7	13,2	10,4	
210					12,3	11,8	10,1	5,7
215					11,9	11,4	10,0	5,6
230						10,2	9,2	5,3
235						9,9	8,8	5,2
260							7,3	4,9
280							6,3	4,7
310								4,3

Main boom 142 ft

Radius (ft)	Jib length in (ft)							
	74	94	113	133	161	181	228	258
112,6	29,5							
125	26,0	25,4						
135	23,6	23,1	22,6					
140	22,5	22,1	21,6					
150		20,2	19,8	19,3				
160		18,6	18,2	17,7				
165			17,5	17,0	16,2			
175			16,1	15,7	14,9	14,4		
195				13,4	12,8	12,3		
205					11,8	11,3	10,0	
220					10,6	10,1	9,0	5,5
225					10,2	9,8	8,7	5,4
240						8,7	7,7	5,1
260							6,5	4,9
290							5,1	4,4
315								3,4

Main boom 181 ft

Radius (ft)	Jib length in (ft)							
	74	94	113	133	161	181	228	258
128,8	22,1							
145	19,0	18,5						
155	17,4	16,9	16,5					
165		15,6	15,1	14,6				
175		14,4	14,0	13,4				
180			13,4	12,9	12,1			
190			12,4	11,9	11,1	10,4		
195			11,9	11,5	10,7	10,1		
210				10,2	9,5	9,0		
220					8,8	8,3	6,4	
235					7,8	7,3	5,6	4,2
240					7,5	7,1	5,4	4,1
260						6,0	4,5	3,2
280							3,8	2,5
295							3,3	2,1
305							3,1	

Main boom 191 ft

Radius (ft)	Jib length in (ft)						
	74	94	113	133	161	181	219
132,9	20,4						
145	18,3	17,7					
155	16,8	16,2	15,7				
160	16,0	15,6	15,1				
170		14,3	13,9	13,3			
180		13,2	12,8	12,2			
185			12,3	11,8	10,9		
195			11,4	10,9	10,1	9,2	
215				9,3	8,6	7,9	
220					8,3	7,6	5,9
240					7,1	6,6	4,9
245					6,8	6,3	4,7
260						5,6	4,1
265						5,3	4,0
280							3,5
300							2,9

Main boom 200 ft

Radius (ft)	Jib length in (ft)				
	74	94	113	133	161
136,7	19,0				
150	16,9	16,3			
160	15,5	15,0	14,4		
165	14,8	14,4	13,9		
170		13,8	13,3	12,7	
185		12,2	11,8	11,2	
190			11,3	10,8	9,8
195			10,9	10,4	9,4
200			10,5	10,0	9,0
205				9,6	8,7
210				9,2	8,4
220				8,5	7,8
225					7,5
230					7,2
240					6,7
250					6,1

TLT 10576462 - M124400 Offiziell

Capacities in 1000 lbs with luffing jib (No. 1309.xx), 137,400 lbs counterweight + 44,100 lbs carbody counterweight. Above lift chart is for reference only. For actual lift duty and complete chart with all available configurations please refer to lift chart in operator's cab or manual.

Lift chart - luffing jib (No. 1309.xx)

Main boom 45°

Main boom 84 ft

Radius	Jib length in (ft)							
	74	94	113	133	161	181	228	258
(ft)	lbs	lbs	lbs	lbs	lbs	lbs	lbs	lbs
129,5	25,5							
140	23,1							
150		20,8						
160		19,1						
161			18,5					
175			16,6					
180				15,5				
195				13,9				
205					12,3			
220					11,0	10,5		
225					10,6	10,1		
240						9,1		
260							6,9	
280							5,9	4,7
290							5,4	4,6
315								3,7

Main boom 123 ft

Radius	Jib length in (ft)							
	74	94	113	133	161	181	228	
(ft)	lbs	lbs	lbs	lbs	lbs	lbs	lbs	
156,7	16,9							
165	15,8							
175		14,1						
185		13,1						
190			12,2					
205			10,8	10,3				
220				9,3				
230					7,9			
245					7,0	6,5		
250					6,8	6,3		
265						5,5		
270						5,3		
285								3,6
290								3,4
300								3,1
315								2,6

Main boom 142 ft

Radius	Jib length in (ft)							
	74	94	113	133	161	181		
(ft)	lbs	lbs	lbs	lbs	lbs	lbs		
170,6	13,4							
180	12,5							
190		11,0						
195		10,6						
200		10,2						
202			9,6					
210			9,1					
215			8,7					
220				7,9				
230				7,3				
235				7,0				
245					5,7			
260					5,1	4,5		
265					4,8	4,3		
285						3,6		

Main boom 181 ft

Radius	Jib length in (ft)							
	74	94	113	133				
(ft)	lbs	lbs	lbs	lbs				
197,7	7,8							
200	7,7							
205	7,3							
215		6,2						
220		6,0						
225		5,7						
230			5,0					
231			5,0					
235			4,8					
240			4,6					
245			4,4					
250				3,6				
255				3,4				
260				3,3				
265				3,1				

Main boom 191 ft

Radius	Jib length in (ft)						
	74	94	113	133			
(ft)	lbs	lbs	lbs	lbs			
204,7	6,5						
215	5,9						
225		4,9					
235		4,4					
238			3,9				
240			3,8				
250			3,4				
255				2,6			
260				2,4			
270				2,2			

Main boom 200 ft

Radius	Jib length in (ft)					
	74	94	113			
(ft)	lbs	lbs	lbs			
211	5,4					
215	5,3					
220	5,0					
230		4,0				
235		3,8				
240		3,6				
245			2,9			
250			2,7			
255			2,6			
260			2,5			

TLT 10576462 - M124400 Offiziell

Capacities in 1000 lbs with luffing jib (No. 1309.xx), 137,400 lbs counterweight + 44,100 lbs carbody counterweight. Above lift chart is for reference only. For actual lift duty and complete chart with all available configurations please refer to lift chart in operator's cab or manual.

Working range - luffing jib (No. 1713.xx) 78° - 15°

Main boom 88° - 45°

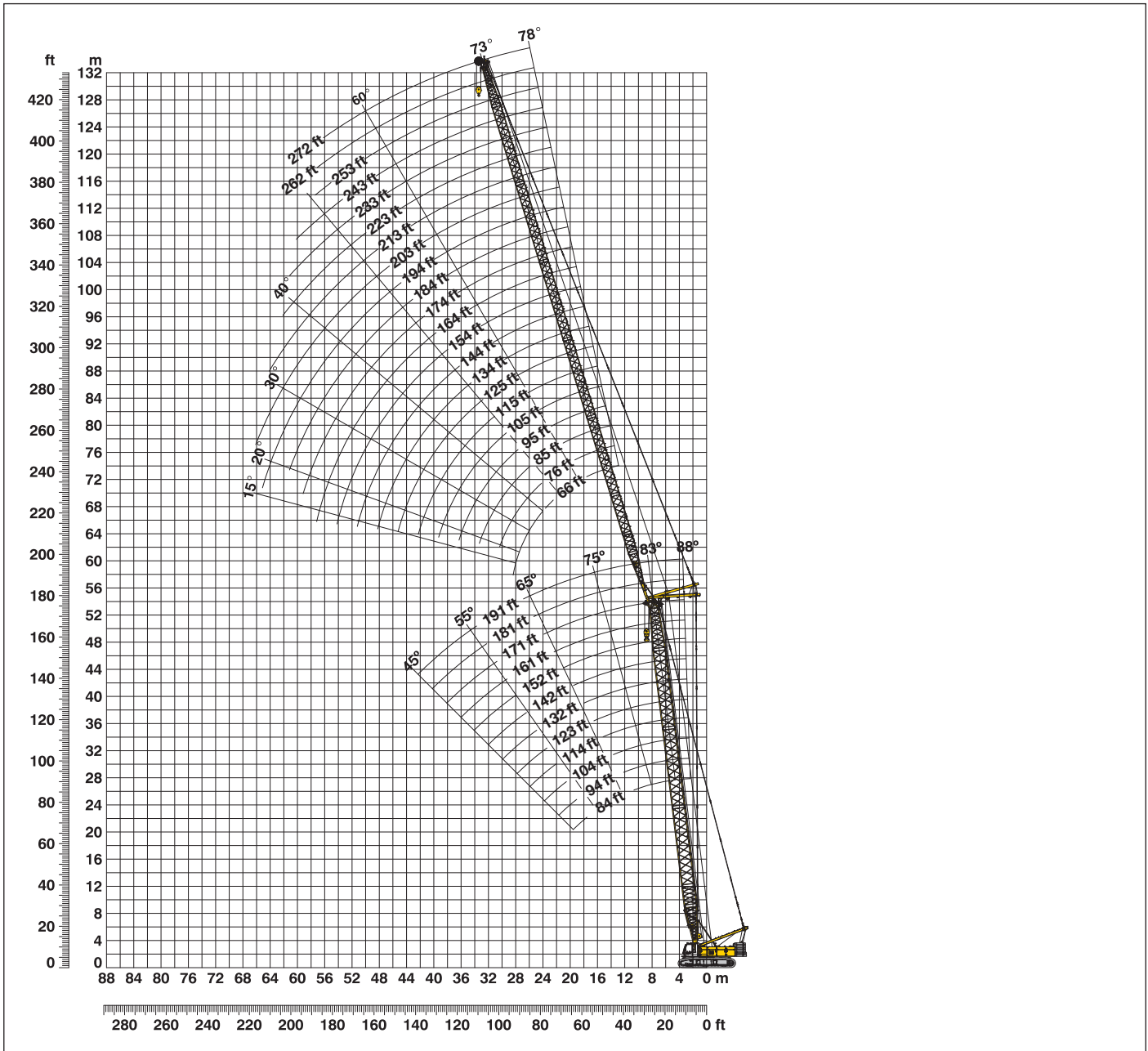

Boom configuration for main boom lengths (84 ft - 191 ft) - see table 1 on page 12

Jib configuration for jib lengths (66 ft - 272 ft)

	Length*	Amount of jib extensions																					
		1	1	1	1	1	1	1	1	1	1	1	1	1	1	1	1	1	1	1	1		
Luffing jib foot	23 ft	1	1	1	1	1	1	1	1	1	1	1	1	1	1	1	1	1	1	1	1		
Luffing jib insert	10 ft		1		1		1		1		1		1		1		1		1		1		
Luffing jib insert	20 ft	1	1		1	1		1	1		1	1		1	1		1	1		1	1		
Luffing jib insert	40 ft			1	1	1	1	2	2	2	2	3	3	3	3	4	4	4	4	5	5	5	5
Luffing jib head	23 ft	1	1	1	1	1	1	1	1	1	1	1	1	1	1	1	1	1	1	1	1	1	1
Luffing jib length (ft)		66	76	85	95	105	115	125	134	144	154	164	174	184	194	203	213	223	233	243	253	262	272

*Actual lengths of boom sections are metric (e.g. 3 m, 6 m, 7 m, 12 m). The figures shown above are approximate conversions to feet.

Lift chart - luffing jib (No. 1713.xx)

Main boom 88°

Main boom 84 ft

Radius (ft)	Jib length in (ft)							
	66 lbs	95 lbs	115 lbs	135 lbs	164 lbs	184 lbs	233 lbs	272 lbs
26,3	130,5							
35	125,4	104,9						
40	110,1	103,8	91,5					
45	98,1	92,4	88,7	74,1				
50	84,3	81,7	78,2	72,8	57,0			
55	76,0	71,8	71,9	67,1	56,1	45,9		
65	61,4	58,7	57,3	56,3	51,3	43,9	27,1	
70	55,1	53,2	52,3	50,8	48,5	42,7	26,6	17,8
75	26,6	50,0	47,6	46,7	45,6	41,8	25,9	17,8
100		34,0	33,6	32,6	31,4	30,5	23,1	15,5
120			26,3	26,4	25,9	23,6	20,6	14,2
140				21,8	21,0	20,1	17,3	13,2
170					15,4	15,1	13,0	10,4
185						12,8	11,0	9,3
235							6,1	5,0
275								2,3

Main boom 123 ft

Radius (ft)	Jib length in (ft)							
	66 lbs	95 lbs	115 lbs	135 lbs	164 lbs	184 lbs	233 lbs	272 lbs
27,6	120,0							
35	109,4	91,4						
40	100,6	87,6	74,9					
45	93,0	82,4	72,2	61,3				
50	83,6	77,5	69,0	59,8	45,6			
55	77,7	71,3	66,3	58,2	45,1	37,8		
65	63,6	60,4	57,3	54,1	43,6	36,9	23,8	
75	51,4	51,1	49,2	47,2	42,0	35,7	23,1	16,0
80		47,2	45,1	45,1	39,7	35,2	22,8	15,9
105		26,6	32,5	31,5	30,1	29,3	20,9	14,2
120			27,1	26,5	26,3	24,2	19,7	13,4
140				22,4	21,4	20,4	17,0	12,4
170					15,8	15,3	13,2	10,3
190						12,3	10,5	9,2
235							6,4	5,3
275								2,5

Main boom 142 ft

Radius (ft)	Jib length in (ft)							
	66 lbs	95 lbs	115 lbs	135 lbs	164 lbs	184 lbs	233 lbs	272 lbs
28,3	103,5							
35	95,1	77,5						
40	88,0	75,3	63,8					
45	81,7	71,6	62,6	52,6				
50	76,3	68,2	60,7	51,4	40,1			
55	71,9	63,8	58,7	50,2	39,7	33,6		
65	62,9	56,9	53,2	47,8	38,2	32,8	21,7	
75	52,5	51,0	47,6	44,3	37,0	31,6	21,3	14,9
80		47,3	44,6	43,1	36,1	31,2	21,0	14,7
105		33,1	32,8	31,7	30,0	28,3	19,4	13,5
125			25,3	25,6	25,2	23,0	18,3	12,5
140				22,5	21,5	20,6	16,4	11,9
170					16,0	15,4	13,2	10,1
190						12,4	10,8	9,3
235							6,4	5,4
275								2,7

Main boom 171 ft

Radius (ft)	Jib length in (ft)							
	66 lbs	95 lbs	115 lbs	135 lbs	164 lbs	184 lbs	233 lbs	272 lbs
29,3	78,7							
40	71,6	53,0	50,3					
45	66,7	53,0	49,6	42,3				
50	62,7	53,0	48,3	41,7	32,8			
55	59,1	50,9	46,9	40,7	32,6	27,9		
65	53,2	47,0	42,9	38,8	31,3	27,2	15,3	
75	48,6	42,8	39,4	36,0	30,1	26,2	14,9	10,6
80		40,9	37,6	35,0	29,4	25,7	14,6	10,5
100		34,4	32,1	30,4	26,7	23,7	13,7	9,6
105		32,6	30,9	29,3	25,8	23,4	13,4	9,4
125			25,6	25,0	23,0	20,8	12,5	8,8
145				21,1	19,4	18,3	11,6	8,3
170					16,0	15,1	10,7	7,5
190						12,5	9,4	7,0
240							5,7	4,4
275								2,3

Main boom 181 ft

Radius (ft)	Jib length in (ft)						
	66 lbs	95 lbs	115 lbs	135 lbs	164 lbs	184 lbs	223 lbs
29,7	72,3						
40	67,2	53,0					
45	62,6	52,2	45,6	39,1			
55	55,6	48,1	43,2	37,7	30,7	26,3	
65	50,1	43,5	39,6	35,9	29,4	25,6	16,1
70	47,9	41,3	38,0	34,5	28,7	25,2	15,7
75	46,2	39,6	36,4	33,3	28,2	24,6	15,2
80		37,9	34,8	32,4	27,5	24,2	14,9
100		32,5	30,1	28,2	25,0	22,2	13,7
105		31,2	29,1	27,4	24,3	21,9	13,5
120			26,1	24,9	22,5	20,2	12,9
125			25,8	24,3	21,9	19,7	12,8
145				21,1	19,2	17,8	11,8
170					15,9	15,2	10,8
190						12,6	10,0
230							6,7

Main boom 191 ft

Radius (ft)	Jib length in (ft)							
	66 lbs	95 lbs	115 lbs	135 lbs	154 lbs	164 lbs	0	0
30	65,9							
40	61,9	49,8						
45	57,9	48,2	42,2	36,5				
50	54,7	46,8	41,1	36,0	27,2			
55	51,6	44,3	39,8	35,3	26,3	24,8		
60	49,1	42,3	38,5	34,2	25,6	24,0		
70	44,5	38,3	35,2	32,0	24,1	22,6		
75	42,9	36,7	33,7	30,6	23,5	22,1		
80		35,2	32,2	29,6	22,8	21,6		
100		30,9	27,9	25,7	20,6	19,6		
105		30,2	27,1	25,0	20,1	19,1		
120			25,3	22,8	18,7	17,7		
125			24,7	22,3	18,2	17,3		
145				20,1	16,4	15,7		
165					11,3	14,4		
170						14,1		

TLT 10576462 - M124400 Offiziel

Capacities in 1000 lbs with luffing jib (No. 1713.xx), 137,400 lbs counterweight + 44,100 lbs carbody counterweight. Above lift chart is for reference only. For actual lift duty and complete chart with all available configurations please refer to lift chart in operator's cab or manual.

Lift chart - luffing jib (No. 1713.xx)

Main boom 83°

Main boom 84 ft

Radius (ft)	Jib length in (ft)							
	66	95	115	135	164	184	233	272
39,3	130,4							
55	88,4	87,0	82,0					
60	79,0	76,1	75,1	69,3				
70	64,5	61,9	59,9	58,6	54,0			
75	58,7	55,8	54,7	53,1	52,0	42,9		
80	53,2	52,1	49,7	48,2	47,6	42,5		
90		44,3	42,4	41,9	40,4	38,7	24,8	
100		38,5	37,1	35,7	35,1	33,4	23,9	15,7
110		32,7	32,7	31,5	30,3	29,5	23,0	15,3
120			29,1	28,0	26,7	25,8	21,5	14,6
130			26,5	26,6	25,0	22,9	20,5	14,0
145				22,6	21,4	20,5	17,9	13,2
175					16,0	15,5	13,3	10,7
195						12,5	10,8	9,3
240							6,4	5,3
280								2,5

Main boom 123 ft

Radius (ft)	Jib length in (ft)							
	66	95	115	135	164	184	233	272
44	108,3							
55	87,1	83,5						
60	78,0	77,3	70,8					
65	70,6	69,9	68,7	59,9				
75	59,1	58,5	58,0	56,6	45,3			
80	54,6	54,0	53,5	52,6	45,0	37,3		
85	50,6	50,1	49,6	48,1	44,3	37,2		
95		43,7	42,5	42,0	39,8	35,9	22,2	
105		38,5	37,2	36,1	35,2	32,4	21,9	14,6
115		33,2	32,9	31,8	30,4	29,6	21,2	14,3
135			26,5	26,6	25,2	23,2	19,4	13,1
150				22,7	21,5	20,6	17,3	12,4
180					16,0	15,5	13,4	10,4
200						12,5	10,9	9,4
245							6,6	5,3
285								2,6

Main boom 142 ft

Radius (ft)	Jib length in (ft)							
	66	95	115	135	164	184	233	272
46,4	92,3							
55	84,5	70,7						
65	69,9	65,4	60,4					
70	63,8	62,5	58,0	51,0				
80	54,0	53,4	52,9	48,3	39,5			
85	50,1	49,6	49,1	46,3	39,0	33,2		
90	26,6	46,2	45,7	44,8	38,6	32,8		
100		40,5	40,1	39,5	36,1	32,0	20,7	
110		36,0	35,6	34,7	33,5	30,4	20,2	13,7
115		34,0	33,6	32,8	31,2	29,7	19,9	13,7
135			26,6	26,5	25,9	23,6	18,7	12,6
155				22,0	21,1	19,3	16,2	11,8
185					15,6	14,6	13,0	10,1
200						12,5	11,0	9,6
250							6,3	5,3
290								2,4

Main boom 171 ft

Radius (ft)	Jib length in (ft)							
	66	95	115	135	164	184	233	272
49,9	70,9							
60	64,2	53,0						
65	60,9	52,0	46,4					
75	55,3	47,8	43,6	39,8				
80	52,7	45,7	41,7	38,5	31,8			
85	49,4	43,8	40,3	37,3	31,6	27,1		
90	45,9	42,2	38,7	36,0	30,9	27,0		
100		39,1	36,0	33,8	29,3	26,0	15,0	
115		33,4	32,2	30,6	27,1	24,3	14,4	10,0
120		31,6	31,1	29,4	26,2	23,9	14,1	9,9
140			25,2	25,2	23,0	21,0	13,3	9,2
160				21,1	19,7	18,3	12,5	8,7
185					16,1	15,1	11,3	8,0
205						12,3	9,7	7,6
255							5,8	4,6
290								2,3

Main boom 181 ft

Radius (ft)	Jib length in (ft)						
	66	95	115	135	164	184	223
51,1	64,8						
60	59,4	49,9					
70	53,4	46,4	42,0				
75	51,1	44,2	40,4	36,6			
80	48,9	42,4	38,7	35,4	29,5		
90	45,5	39,1	35,9	33,1	28,7	25,2	
95	26,6	37,7	34,5	32,2	28,0	24,8	
100		36,4	33,3	31,2	27,2	24,2	15,4
110		34,2	31,3	29,1	25,9	23,1	14,9
120		31,4	29,5	27,6	24,5	22,1	14,5
130			27,8	26,1	23,2	20,9	14,0
140			25,4	24,8	22,1	19,9	13,6
160				20,9	19,6	17,9	12,4
190					15,5	14,7	10,9
205						12,8	10,2
245							7,0

Main boom 191 ft

Radius (ft)	Jib length in (ft)					
	66	95	115	135	154	164
55	57,8					
65	52,1	44,6				
70	49,2	42,7	38,5			
75	47,1	40,7	37,0	33,2		
80	45,1	39,1	35,5	32,2	25,7	
85	43,4	37,3	34,1	31,2	25,2	23,8
95	40,5	34,6	31,7	29,0	23,8	22,6
100		33,5	30,5	28,2	23,1	22,0
120		29,9	27,1	24,8	20,7	19,8
130			25,8	23,5	19,7	18,7
140			24,5	22,3	18,7	17,9
150				21,4	17,8	17,0
160				20,3	17,1	16,2
170					16,3	15,6
180					13,8	14,9
190						12,7

TLT 10576462 - M124400 Offiziell

Capacities in 1000 lbs with luffing jib (No. 1713.xx), 137,400 lbs counterweight + 44,100 lbs carbody counterweight. Above lift chart is for reference only. For actual lift duty and complete chart with all available configurations please refer to lift chart in operator's cab or manual.

Lift chart - luffing jib (No. 1713.xx)

Main boom 75°

Main boom 84 ft

Radius (ft)	Jib length in (ft)							
	66	95	115	135	164	184	233	272
60	75,8							
75	57,4	56,7						
85	49,2	48,5	48,0					
90	45,8	45,2	44,7	44,2				
95	26,6	42,3	41,8	41,3				
105		37,3	36,8	36,4	35,6			
110		35,2	34,8	34,3	33,5	32,6		
120		31,5	31,1	30,7	30,0	29,4		
135			26,7	26,4	25,7	25,1	21,1	
140			25,5	25,2	24,5	23,9	20,7	
150				22,9	22,3	21,8	19,1	13,3
160				21,0	20,4	19,7	17,6	13,2
190					15,2	14,5	12,7	10,5
205						12,6	10,6	9,0
255							6,1	4,7
290								2,7

Main boom 123 ft

Radius (ft)	Jib length in (ft)							
	66	95	115	135	164	184	233	272
70	59,8							
85	47,1	46,2						
95	41,0	40,3	39,7					
100	38,5	37,8	37,2	36,7				
105	26,6	35,6	35,0	34,4				
120		30,1	29,5	29,0	28,2	27,6		
125		28,5	28,0	27,5	26,7	26,2		
130		27,1	26,6	26,2	25,4	24,8		
145			23,1	22,7	22,0	21,4	19,7	
150			22,1	21,7	20,9	20,4	18,9	
160				19,8	19,1	18,6	17,2	12,5
170				18,2	17,6	17,0	15,6	12,2
200					13,7	13,3	11,9	10,3
215						11,8	10,5	9,1
265							6,3	4,9
300								2,8

Main boom 142 ft

Radius (ft)	Jib length in (ft)							
	66	95	115	135	164	184	233	272
75	53,5							
90	42,7	41,8						
100	37,5	36,7	36,0					
105	35,2	34,5	33,9	33,3				
110	26,6	32,6	31,9	31,4				
120		29,2	28,6	28,0	27,2			
125		27,7	27,1	26,6	25,8	25,1		
135		25,1	24,6	24,1	23,3	22,7		
150			21,4	20,9	20,2	19,6	17,6	
155			20,4	20,0	19,3	18,7	16,8	
165				18,3	17,6	17,0	15,3	11,8
175				16,8	16,2	15,6	14,0	11,7
205					12,7	12,2	10,8	8,9
220						10,8	9,5	7,7
270							6,1	4,8
305								2,9

Main boom 171 ft

Radius (ft)	Jib length in (ft)							
	66	95	115	135	164	184	233	272
81,8	45,9							
95	38,2	37,2						
105	33,7	32,8	32,1					
115	30,0	29,2	28,6	28,0				
125		26,3	25,7	25,2	24,3			
135		23,8	23,3	22,7	21,9	21,0		
145		21,6	21,2	20,7	19,8	19,1		
155			19,3	18,8	18,1	17,4	12,8	
165			17,7	17,3	16,5	15,9	12,7	
170				16,5	15,8	15,2	12,5	8,3
180				15,2	14,5	13,9	11,6	8,3
200					12,3	11,7	9,7	7,7
210						11,3	10,8	8,9
230							9,2	7,5
275								5,1
310								2,1

Main boom 181 ft

Radius (ft)	Jib length in (ft)						
	66	95	115	135	164	184	223
84,4	43,4						
100	35,2	34,2					
110	31,2	30,3	29,7				
115	29,5	28,7	28,0	27,4			
120	26,6	27,2	26,6	26,0			
130		24,6	23,9	23,4	22,5		
135		23,4	22,8	22,2	21,4	20,1	
145		21,2	20,7	20,2	19,4	18,3	
155			18,9	18,4	17,6	16,8	12,5
160			18,1	17,6	16,8	16,0	12,5
165			17,3	16,9	16,1	15,4	12,3
180				14,8	14,1	13,5	11,5
185				14,2	13,5	12,9	11,0
215					10,6	10,1	8,5
230						8,9	7,5
270							5,4

Main boom 191 ft

Radius (ft)	Jib length in (ft)					
	66	95	115	135	154	164
86,9	41,1					
100	34,5	33,5				
110	30,6	29,7	29,0			
120	27,4	26,6	26,0	25,3		
125		25,3	24,6	24,0	19,7	
130		24,0	23,4	22,8	19,5	18,3
140		21,8	21,2	20,7	18,5	17,6
150		19,8	19,3	18,8	17,4	16,7
160			17,7	17,2	16,6	15,9
170			16,2	15,7	15,2	15,0
180				14,5	13,9	13,7
185				13,9	13,3	13,2
200					11,8	11,6
205					11,3	11,1
210						10,7
215						10,3

TLT 10576462 - M124400 Offiziell

Capacities in 1000 lbs with luffing jib (No. 1713.xx), 137,400 lbs counterweight + 44,100 lbs carbody counterweight. Above lift chart is for reference only. For actual lift duty and complete chart with all available configurations please refer to lift chart in operator's cab or manual.

Lift chart - luffing jib (No. 1713.xx)

Main boom 65°

Main boom 84 ft

Radius (ft)	Jib length in (ft)							
	66 lbs	95 lbs	115 lbs	135 lbs	164 lbs	184 lbs	233 lbs	272 lbs
83	47,9							
100	38,0	37,2						
105	35,7	35,0						
115		31,3	30,7					
125		28,1	27,6	27,1				
135		25,5	25,0	24,5				
140			23,8	23,4	22,5			
155			20,8	20,4	19,6	19,0		
175				17,1	16,5	15,9		
180					15,8	15,3	13,8	
200					13,5	12,9	11,6	
205						12,4	11,1	10,0
220						11,0	9,7	8,6
240							8,2	7,1
270							6,0	4,5
305								2,6

Main boom 123 ft

Radius (ft)	Jib length in (ft)							
	75 lbs	95 lbs	115 lbs	135 lbs	164 lbs	184 lbs	233 lbs	272 lbs
104,8	32,6							
120	27,5	27,0						
130	24,8	24,4	23,7					
140		22,1	21,5	20,9				
150		20,1	19,6	19,1				
160			17,9	17,4	16,6			
170			16,4	16,0	15,2	14,5		
190				13,5	12,8	12,2		
200					11,8	11,2	9,6	
220						10,0	9,5	8,0
225							9,1	7,6
235							8,4	7,0
260								5,5
285								4,2
300								2,2
305								2,1

Main boom 142 ft

Radius (ft)	Jib length in (ft)							
	66 lbs	95 lbs	115 lbs	135 lbs	164 lbs	184 lbs	233 lbs	272 lbs
107,5	30,3							
125	25,0	24,1						
130	23,8	22,9						
140		20,8	20,1					
150		18,9	18,3	17,7				
160		17,3	16,7	16,2				
165			16,0	15,5	14,6			
180			14,1	13,6	12,8	12,2		
200				11,5	10,8	10,2		
205					10,4	9,7	7,7	
225					8,8	8,2	6,3	
230						7,9	6,0	4,1
245							6,9	5,2
255								4,7
275								3,8
295								3,0

Main boom 171 ft

Radius (ft)	Jib length in (ft)							
	66 lbs	95 lbs	115 lbs	135 lbs	164 lbs	184 lbs	233 lbs	272 lbs
119,6	24,1							
140	19,6	18,7						
145	18,7	17,8						
150		17,0	16,3					
160		15,5	14,9	14,2				
170		14,2	13,6	13,0				
180			12,5	11,9	11,1			
185				12,0	11,4	10,6		
190				11,5	11,0	10,1	9,1	
210					9,2	8,5	7,6	
220						7,8	7,0	4,4
240						6,5	5,9	3,4
245							5,6	3,2
255							5,1	2,8
265								2,4
275								2,1

Main boom 181 ft

Radius (ft)	Jib length in (ft)							
	66 lbs	95 lbs	115 lbs	135 lbs	164 lbs	184 lbs	223 lbs	272 lbs
123,7	22,2							
145	18,0	17,1						
165		14,2	13,6	13,0				
175		13,0	12,4	11,8				
185			11,4	10,8	9,8			
195			10,4	9,9	9,0	7,9		
215				8,3	7,6	6,5	4,5	
220					7,2	6,3	4,3	
230					6,6	5,7	3,7	
235					6,3	5,5	3,5	
240					6,0	5,2	3,3	
245						5,0	3,1	
250						4,8	2,9	
260						4,4	2,5	
265							2,3	
270							2,1	

Main boom 191 ft

Radius (ft)	Jib length in (ft)							
	66 lbs	95 lbs	115 lbs	135 lbs	154 lbs	164 lbs	223 lbs	272 lbs
127,9	20,4							
145	17,3	16,2						
150	16,5	15,5						
160		14,2	13,4					
170		13,0	12,3	11,7				
180		11,9	11,2	10,7	9,6			
185			10,8	10,2	9,2	8,8		
190			10,3	9,7	8,8	8,4		
195			9,9	9,3	8,4	8,1		
200			9,4	8,9	8,1	7,7		
210				8,2	7,4	7,1		
220				7,5	6,9	6,5		
230					6,3	6,0		
235					6,0	5,8		
240						5,5		
245						5,3		

TLT 10576462 - M124400 Offiziell

Capacities in 1000 lbs with luffing jib (No. 1713.xx), 137,400 lbs counterweight + 44,100 lbs carbody counterweight. Above lift chart is for reference only. For actual lift duty and complete chart with all available configurations please refer to lift chart in operator's cab or manual.

Lift chart - luffing jib (No. 1713.xx)

Main boom 45°

Main boom 84 ft

Radius (ft)	Jib length in (ft)							
	66 lbs	85 lbs	115 lbs	135 lbs	164 lbs	184 lbs	233 lbs	272 lbs
122,3	26,4							
130	24,4							
140		21,7						
150		19,8						
165			16,5					
180			14,6	14,1				
195				12,5				
205					10,8			
220					9,5	8,9		
225					9,1	8,6		
245						7,2		
260							4,9	
290							3,5	
295								2,1

Main boom 123 ft

Radius (ft)	Jib length in (ft)						
	66 lbs	95 lbs	115 lbs	135 lbs	164 lbs	184 lbs	
149,5	17,0						
160	15,4						
175		12,7					
185		11,7					
190			10,5				
205			9,3				
210				8,4			
225				7,4			
235					6,0		
240					5,7		
250					5,2	4,6	
255					4,9	4,3	
260						4,1	
270						3,7	

Main boom 142 ft

Radius (ft)	Jib length in (ft)					
	66 lbs	95 lbs	115 lbs	135 lbs	164 lbs	184 lbs
163,4	13,2					
170	12,5					
190		9,6				
200		8,8				
205			7,8			
220			6,8	6,2		
240				5,1		
244					4,1	
265					3,2	2,5
280					2,0	2,0

Main boom 171 ft

Radius (ft)	Jib length in (ft)				
	66 lbs	95 lbs	115 lbs	135 lbs	
183,6	8,6				
190	8,1				
210		5,8			
220		5,2			
225			4,3		
235			3,9		
240			3,6	2,9	
250				2,6	
255				2,5	
260				2,3	

Main boom 181 ft

Radius (ft)	Jib length in (ft)		
	66 lbs	95 lbs	115 lbs
190,5	7,1		
200	6,5		
215		4,7	
225		4,2	
235			3,1
245			2,7

Main boom 191 ft

Radius (ft)	Jib length in (ft)		
	66 lbs	95 lbs	
197,5	5,8		
200	5,7		
205	5,4		
225		3,4	
230		3,2	
235		3,0	

TLT 10576462 - M124400 Offiziell

Capacities in 1000 lbs with luffing jib (No. 1713.xx), 137,400 lbs counterweight + 44,100 lbs carbody counterweight. Above lift chart is for reference only. For actual lift duty and complete chart with all available configurations please refer to lift chart in operator's cab or manual.

Working range - fixed jib (No. 0806.xx) 15° and 30°

Main boom 88° - 45°

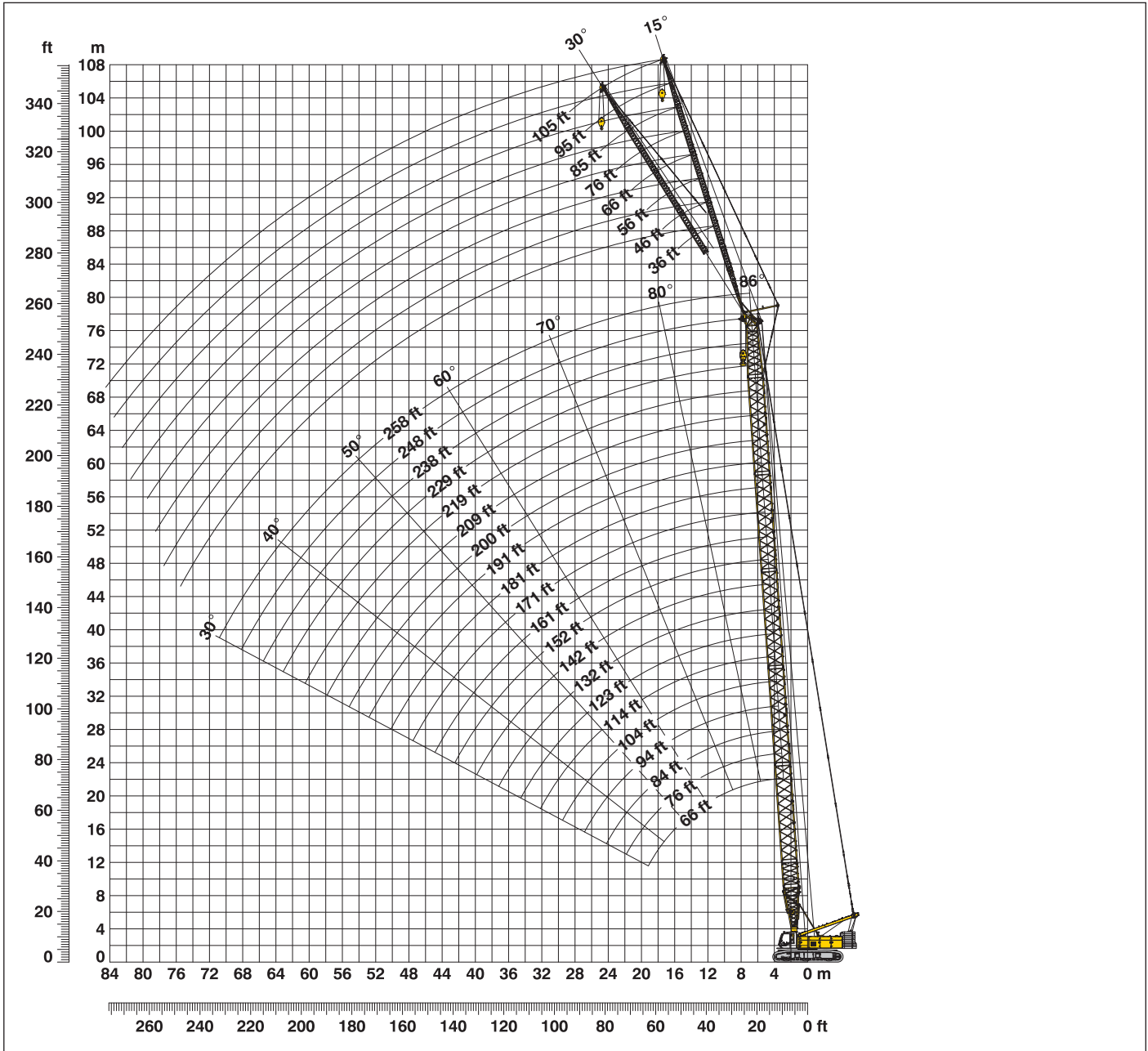

Boom configuration for boom lengths (66 ft - 258 ft) - see table 1 on page 12

Fixed jib configuration for fixed jib lengths (36 ft - 105 ft)

	Length*	Amount of fixed jib extensions							
Fixed jib foot	18 ft	1	1	1	1	1	1	1	1
Fixed jib insert	10 ft		1		1		1		1
Fixed jib insert	20 ft			1	1	2	2	3	3
Fixed jib head	18 ft	1	1	1	1	1	1	1	1
Fixed jib length (m)		36	46	56	66	76	85	95	105

*Actual lengths of boom sections are metric (e.g. 3 m, 6 m). The figures shown above are approximate conversions to feet.

Lift chart - fixed jib (No. 0806.xx)

Offset 15°

Main boom 66 ft

Radius	Fixed jib length in (ft)			
	36	66	85	105
(ft)	lbs	lbs	lbs	lbs
25	53,0			
35	53,0	37,9		
40	53,0	36,8	23,1	
50	53,0	34,7	21,9	13,2
60	53,0	32,4	20,7	12,5
70	50,4	30,0	19,5	11,8
80	44,9	27,4	18,3	11,3
90	40,7	24,9	17,4	10,8
100	36,6	23,2	16,6	10,4
130		19,0	14,5	9,5
145			13,7	9,1
165				9,1

Main boom 94 ft

Radius	Fixed jib length in (ft)			
	36	66	85	105
(ft)	lbs	lbs	lbs	lbs
20,3	53,0			
35	53,0	38,4		
45	53,0	36,6	23,0	
50	53,0	35,8	22,5	13,2
60	53,0	34,1	21,5	12,6
80	52,7	30,4	19,5	11,5
100	39,9	26,0	17,7	10,6
120	31,1	23,2	16,3	10,0
125	26,6	22,4	16,0	9,8
150		19,9	14,7	9,3
170			13,8	9,0
190				9,0

Main boom 132 ft

Radius	Fixed jib length in (ft)			
	36	66	85	105
(ft)	lbs	lbs	lbs	lbs
21,6	53,0			
35	53,0	37,4		
45	53,0	36,2	22,7	
55	53,0	34,9	21,9	12,8
60	53,0	34,3	21,5	12,6
80	52,5	31,8	19,9	11,7
100	38,9	29,0	18,4	10,9
120	30,1	25,5	17,2	10,2
155	20,6	21,5	15,5	9,4
185		16,4	14,4	9,0
205			13,7	8,9
225				8,8

Main boom 171 ft

Radius	Fixed jib length in (ft)			
	36	66	85	105
(ft)	lbs	lbs	lbs	lbs
23	53,0			
40	53,0	35,4		
45	53,0	35,0	22,1	
55	53,0	34,0	21,5	12,7
60	53,0	33,6	21,2	12,5
80	51,4	31,7	20,0	11,7
120	29,0	27,8	17,7	10,5
160	18,5	19,6	15,8	9,5
190	13,6	14,6	14,9	9,1
220		10,9	11,5	8,7
240			9,5	8,7
260				8,0

Main boom 191 ft

Radius	Fixed jib length in (ft)			
	36	66	85	105
(ft)	lbs	lbs	lbs	lbs
23,6	53,0			
40	53,0	34,5		
45	53,0	34,2	21,7	
55	53,0	33,3	21,2	12,6
80	50,9	31,2	19,8	11,7
120	28,4	28,1	17,8	10,5
160	17,9	19,0	16,1	9,7
200	11,7	12,7	13,3	9,0
205	11,0	12,1	12,6	9,0
235		8,9	9,4	8,6
250			8,1	8,5
275				6,6

Main boom 219 ft

Radius	Fixed jib length in (ft)			
	36	66	85	105
(ft)	lbs	lbs	lbs	lbs
24,6	53,0			
40	53,0	31,8		
50	53,0	31,5	20,2	
55	52,5	31,2	20,1	12,5
80	49,3	29,4	19,0	11,6
120	27,6	26,9	17,3	10,6
160	17,0	18,2	15,9	9,7
200	10,8	11,9	12,5	9,1
230	7,6	8,6	9,1	8,8
260		6,0	6,5	7,0
280			5,1	5,5
300				4,2

Main boom 238 ft

Radius	Fixed jib length in (ft)			
	36	66	85	105
(ft)	lbs	lbs	lbs	lbs
25,3	53,0			
40	51,9	30,6		
50	50,3	30,1	19,8	
55	49,5	29,8	19,6	12,2
80	45,6	28,1	18,5	11,5
120	27,0	25,6	16,9	10,5
160	16,5	17,7	15,5	9,7
200	10,2	11,3	11,9	9,1
245	5,7	6,6	7,2	7,7
275		4,3	4,9	5,4
295			3,6	4,0
315				2,9

Main boom 248 ft

Radius	Fixed jib length in (ft)			
	36	66	85	105
(ft)	lbs	lbs	lbs	lbs
25,6	50,6			
40	49,1	30,0		
50	47,4	29,6	19,5	
55	46,6	29,2	19,3	11,3
80	42,6	27,4	18,3	10,6
120	26,7	25,0	16,8	9,4
160	16,1	17,4	15,5	8,7
200	9,9	11,0	11,6	8,2
255	4,6	5,5	6,1	6,6
285		3,4	3,9	4,4
305			2,7	3,1
325				2,0

Main boom 258 ft

Radius	Fixed jib length in (ft)			
	36	46	66	85
(ft)	lbs	lbs	lbs	lbs
26	48,4			
35	47,6	40,4		
40	46,8	39,9	28,4	
50	45,2	38,6	27,8	17,7
80	40,0	34,7	25,5	16,6
120	26,5	27,0	23,3	15,0
160	15,8	16,3	17,1	13,6
240	5,5	5,8	6,5	7,0
265	3,5	3,8	4,4	5,0
275		3,1	3,7	4,3
295			2,4	3,0
310				2,1

TLT 10576462 - M124400 Offiziell

Capacities in 1000 lbs with fixed jib (No. 0806.xx), 137,400 lbs counterweight + 44,100 lbs carbody counterweight. Above lift chart is for reference only. For actual lift duty and complete chart with all available configurations please refer to lift chart in operator's cab or manual.

Lift chart - fixed jib (No. 0806.xx)

Offset 30°

Main boom 66 ft

Radius	Fixed jib length in (ft)			
	36	66	85	105
(ft)	lbs	lbs	lbs	lbs
30	53,0			
50	50,8	30,0		
60	46,3	27,3	18,3	
75	40,1	24,1	16,9	10,6
80	38,6	23,1	16,5	10,4
100	34,3	20,3	15,1	9,7
120		18,5	14,1	9,3
130		18,2	13,7	9,1
140			13,3	9,1
150			13,1	9,1
160				9,1
170				9,1

Main boom 94 ft

Radius	Fixed jib length in (ft)			
	36	66	85	105
(ft)	lbs	lbs	lbs	lbs
29,1	53,0			
50	53,0	31,1		
65	48,1	27,6	18,2	
75	44,7	25,7	17,5	10,6
80	42,9	24,9	17,1	10,4
100	37,8	22,2	15,9	9,8
110	35,4	21,0	15,3	9,6
120	31,3	20,2	14,9	9,4
125	29,5	19,8	14,7	9,3
155		18,4	13,6	9,0
175			13,3	9,0
195				9,0

Main boom 132 ft

Radius	Fixed jib length in (ft)			
	36	66	85	105
(ft)	lbs	lbs	lbs	lbs
30,4	53,0			
50	53,0	30,8		
65	51,5	28,3	18,2	
75	48,5	26,7	17,5	10,5
80	47,0	26,0	17,2	10,4
100	39,4	23,5	16,2	9,9
120	30,5	21,7	15,4	9,5
140	24,4	20,2	14,7	9,2
160	19,7	18,9	14,2	9,0
185		16,5	13,5	8,9
205			13,3	8,9
225				8,9

Main boom 171 ft

Radius	Fixed jib length in (ft)			
	36	66	85	105
(ft)	lbs	lbs	lbs	lbs
31,7	53,0			
55	52,8	29,7		
65	52,3	28,6	18,0	
80	49,7	26,7	17,3	10,3
100	38,5	24,5	16,4	9,9
120	29,6	22,7	15,7	9,6
140	23,4	21,4	15,0	9,3
160	18,8	20,2	14,5	9,0
190	13,7	15,0	13,9	8,8
220		11,0	11,8	8,8
240			9,6	8,8
260				8,3

Main boom 191 ft

Radius	Fixed jib length in (ft)			
	36	66	85	105
(ft)	lbs	lbs	lbs	lbs
32,4	53,0			
55	52,5	29,1		
65	51,4	28,5	17,7	
80	49,5	26,9	17,2	10,2
100	38,0	24,9	16,4	9,9
120	29,0	23,2	15,7	9,6
140	22,8	21,9	15,1	9,3
180	14,7	16,0	14,2	8,9
210	10,6	11,8	12,5	8,7
240		8,5	9,2	8,7
255			7,8	8,4
275				6,7

Main boom 219 ft

Radius	Fixed jib length in (ft)			
	36	66	85	105
(ft)	lbs	lbs	lbs	lbs
33,4	50,6			
55	49,3	27,3		
65	48,4	26,8	16,9	
80	47,0	26,3	16,4	10,2
100	37,3	24,6	16,0	9,8
120	28,3	23,2	15,4	9,5
160	17,5	19,0	14,4	9,1
200	11,1	12,3	13,1	8,8
235	7,2	8,4	9,1	8,6
260		6,1	6,8	7,4
280			5,2	5,8
300				4,3

Main boom 238 ft

Radius	Fixed jib length in (ft)			
	36	66	85	105
(ft)	lbs	lbs	lbs	lbs
34,1	47,5			
55	46,3	25,9		
70	44,7	25,4	16,2	
80	43,7	24,8	16,0	10,0
120	27,8	22,8	14,9	9,5
160	16,9	18,6	14,1	9,0
200	10,5	11,9	12,7	8,7
240	6,3	7,4	8,1	8,5
250	5,4	6,5	7,2	7,9
280		4,1	4,8	5,4
300			3,3	4,0
320				2,6

Main boom 248 ft

Radius	Fixed jib length in (ft)			
	36	66	85	105
(ft)	lbs	lbs	lbs	lbs
34,4	44,9			
55	43,0	25,6		
70	41,0	25,1	16,0	
80	39,7	24,6	15,8	9,3
120	27,5	22,7	14,8	8,9
160	16,6	18,3	14,1	8,4
200	10,2	11,6	12,4	8,1
240	6,0	7,1	7,8	7,9
260	4,3	5,4	6,1	6,7
285		3,5	4,1	4,8
305			2,8	3,4
325				2,1

Main boom 258 ft

Radius	Fixed jib length in (ft)			
	36	46	66	85
(ft)	lbs	lbs	lbs	lbs
34,8	42,8			
45	42,0	35,9		
55	40,5	35,1	24,4	
70	38,1	33,3	23,9	14,3
120	27,3	28,0	22,0	12,7
160	16,4	16,9	18,1	11,7
200	9,9	10,4	11,3	11,0
240	5,7	6,1	6,9	7,6
265	3,6	4,0	4,7	5,4
275		3,2	3,9	4,6
295			2,5	3,2
310				2,2

TLT 10576404 - M118422

Capacities in 1000 lbs with fixed jib (No. 0806.xx), 137,400 lbs counterweight + 44,100 lbs carbody counterweight. Above lift chart is for reference only. For actual lift duty and complete chart with all available configurations please refer to lift chart in operator's cab or manual.

Working range - fixed jib (No. 1008.xx) 15° and 30°

Main boom 88° - 30°

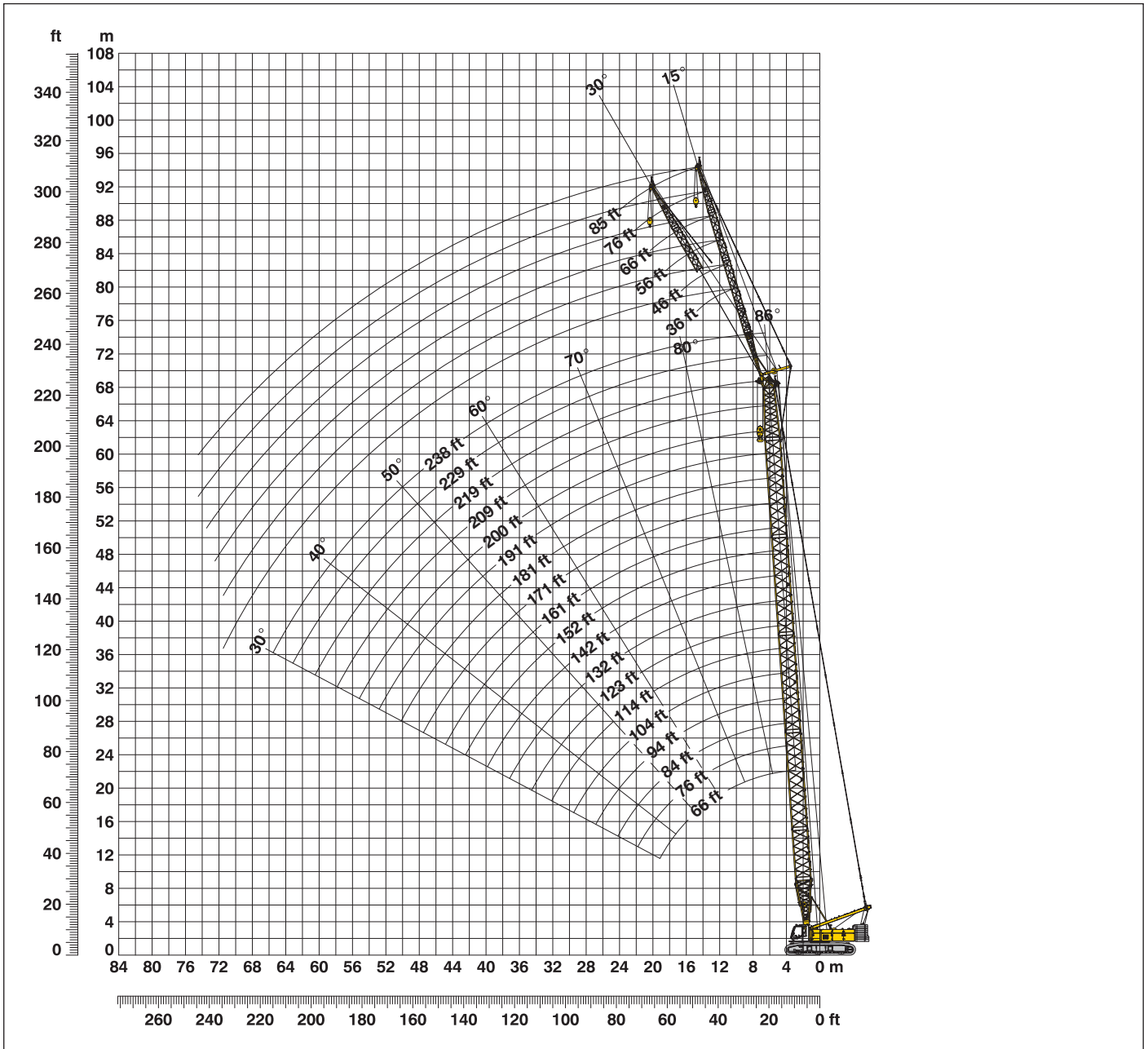

Boom configuration for boom lengths (66 ft - 238 ft) - see table 1 on page 12

Fixed jib configuration for fixed jib lengths (36 ft - 85 ft)

	Length*	Amount of fixed jib extensions					
Fixed jib foot	18 ft	1	1	1	1	1	1
Fixed jib insert	10 ft		1		1		1
Fixed jib insert	20 ft			1	1	2	2
Fixed jib head	18 ft	1	1	1	1	1	1
Fixed jib length (m)		11	14	17	20	23	26

*Actual lengths of boom sections are metric (e.g. 3 m, 6 m). The figures shown above are approximate conversions to feet.

Lift chart - fixed jib (No. 1008.xx)

Offset 15°

Main boom 66 ft

Radius	Fixed jib length in (ft)			
	36	46	66	85
(ft)	lbs	lbs	lbs	lbs
18,6	79,1			
25	79,1	79,1		
35	79,1	75,9	55,6	
40	78,6	70,2	52,0	42,9
50	77,3	61,5	46,7	37,9
60	75,5	56,9	41,6	33,8
70	62,3	55,9	37,5	30,5
80	52,3	51,9	37,1	27,4
100	38,6	39,1	33,4	26,6
110		34,2	30,3	25,6
125			27,7	23,0
145				20,4

Main boom 94 ft

Radius	Fixed jib length in (ft)			
	36	46	66	85
(ft)	lbs	lbs	lbs	lbs
19,6	79,1			
25	79,1	78,0		
35	79,1	74,6	62,8	
40	79,1	73,1	60,2	45,4
60	75,8	67,0	51,5	39,1
80	51,6	52,1	42,8	33,0
100	37,9	38,4	38,1	28,4
120	29,2	29,6	30,3	26,3
125	26,6	27,8	28,5	25,7
135		24,7	25,5	24,3
150			21,6	22,1
170				18,0

Main boom 132 ft

Radius	Fixed jib length in (ft)			
	36	46	66	85
(ft)	lbs	lbs	lbs	lbs
20,9	79,1			
25	79,1	79,1		
35	79,1	78,2	68,2	
45	79,1	75,4	65,0	46,6
60	74,9	70,2	57,6	43,7
80	50,5	51,1	49,1	37,8
100	36,9	37,3	38,1	32,7
120	28,1	28,5	29,2	28,7
155	18,5	18,8	19,4	19,9
165		16,8	17,4	17,9
185			14,0	14,5
205				11,7

Main boom 152 ft

Radius	Fixed jib length in (ft)			
	36	46	66	85
(ft)	lbs	lbs	lbs	lbs
21,6	79,1			
30	79,1	78,9		
35	79,1	78,0	65,9	
45	79,1	74,7	63,1	45,2
60	74,4	70,4	56,8	42,9
80	50,0	50,5	49,2	38,2
120	27,5	27,9	28,6	29,2
160	16,9	17,2	17,8	18,3
175	14,2	14,5	15,0	15,5
185		12,9	13,5	13,9
200			11,4	11,8
220				9,4

Main boom 171 ft

Radius	Fixed jib length in (ft)			
	36	46	66	85
(ft)	lbs	lbs	lbs	lbs
22,3	79,1			
30	79,1	75,7		
35	79,1	75,6	60,9	
45	79,1	73,3	59,9	43,4
60	73,9	69,3	55,1	41,7
80	49,5	50,1	48,0	37,9
120	27,0	27,3	28,1	28,7
160	16,4	16,7	17,3	17,8
190	11,4	11,7	12,2	12,6
200		10,3	10,9	11,3
220			8,5	8,9
240				6,9

Main boom 191 ft

Radius	Fixed jib length in (ft)			
	36	46	66	85
(ft)	lbs	lbs	lbs	lbs
22,9	79,1			
30	79,1	72,4		
35	78,9	72,1	55,9	
45	78,2	70,2	55,8	41,0
80	48,9	49,5	46,5	36,9
120	26,4	26,7	27,5	28,2
160	15,7	16,0	16,6	17,2
200	9,5	9,7	10,2	10,7
205	8,8	9,1	9,6	10,0
215		7,9	8,4	8,9
235			6,4	6,8
255				5,0

Main boom 219 ft

Radius	Fixed jib length in (ft)			
	36	46	66	85
(ft)	lbs	lbs	lbs	lbs
23,9	67,5			
30	67,1	59,8		
40	65,2	59,2	47,1	
45	64,0	58,3	47,1	36,8
80	48,2	48,8	41,4	33,8
120	25,5	25,9	26,7	27,5
160	14,9	15,2	15,8	16,4
190	9,9	10,2	10,7	11,2
230	5,4	5,6	6,0	6,4
240		4,6	5,1	5,5
260			3,4	3,8
280				2,3

Main boom 229 ft

Radius	Fixed jib length in (ft)			
	36	46	56	66
(ft)	lbs	lbs	lbs	lbs
24,3	62,1			
30	61,6	54,7		
35	60,8	54,3	48,3	
40	59,6	53,8	48,3	43,2
80	47,9	45,9	42,8	39,1
120	25,2	25,6	26,1	26,5
160	14,5	14,8	15,2	15,5
200	8,3	8,5	8,8	9,0
240	4,1	4,3	4,6	4,8
250		3,5	3,7	3,9
255			3,3	3,5
270				2,4

Main boom 238 ft

Radius	Fixed jib length in (ft)			
	36	46		
(ft)	lbs	lbs		
25,5	53,0			
30	53,0	50,3		
40	53,0	50,2		
60	51,2	47,1		
80	45,8	42,3		
100	33,8	34,3		
120	24,9	25,4		
140	18,8	19,2		
160	14,3	14,6		
200	8,0	8,3		
240	3,9	4,1		
255		2,8		

TLT 10576404 - M118422

Capacities in 1000 lbs with fixed jib (No. 1008.xx), 137,400 lbs counterweight + 44,100 lbs carbody counterweight. Above lift chart is for reference only. For actual lift duty and complete chart with all available configurations please refer to lift chart in operator's cab or manual.

Lift chart - fixed jib (No. 1008.xx)

Offset 30°

Main boom 66 ft

Radius	Fixed jib length in (ft)			
	36	46	66	85
(ft)	lbs	lbs	lbs	lbs
27,3	70,2			
35	64,9	52,8		
50	56,4	46,1	33,9	
60	53,2	42,5	31,2	25,6
65	53,0	40,7	30,0	24,6
70	53,0	40,5	28,9	23,7
80	50,2	40,0	26,8	22,0
90	45,0	37,6	26,6	20,5
100	38,7	35,2	26,4	19,4
110		34,0	25,1	19,0
130			23,1	17,3
150				16,2

Main boom 94 ft

Radius	Fixed jib length in (ft)			
	36	46	66	85
(ft)	lbs	lbs	lbs	lbs
28,3	74,3			
35	71,8	59,6		
50	65,0	54,2	37,8	
60	60,2	51,7	35,2	26,8
70	56,3	48,1	32,8	25,9
80	52,3	45,3	30,7	24,2
100	38,4	39,0	27,6	21,4
120	29,3	29,9	26,1	19,4
125	27,5	28,1	25,7	19,0
135		24,9	24,8	18,2
155			20,6	16,7
175				16,1

Main boom 132 ft

Radius	Fixed jib length in (ft)			
	36	46	66	85
(ft)	lbs	lbs	lbs	lbs
29,7	79,1			
40	78,5	64,8		
50	74,8	61,5	42,2	
60	68,6	57,2	39,2	28,4
80	51,5	50,1	34,1	26,6
100	37,5	38,1	30,4	23,6
120	28,5	29,1	27,6	21,2
150	19,8	20,2	21,1	18,4
160	17,6	18,0	18,8	17,9
170		16,0	16,8	17,3
185			14,2	14,9
205				11,9

Main boom 152 ft

Radius	Fixed jib length in (ft)			
	36	46	66	85
(ft)	lbs	lbs	lbs	lbs
30,4	79,1			
40	78,4	64,7		
50	74,8	61,5	41,9	
65	67,1	55,7	38,1	28,2
80	51,0	50,7	34,8	25,9
100	37,0	37,6	31,3	24,0
120	28,0	28,5	28,5	21,9
160	17,1	17,5	18,3	18,3
175	14,3	14,7	15,4	16,1
185		13,0	13,8	14,4
205			10,8	11,5
225				9,0

Main boom 171 ft

Radius	Fixed jib length in (ft)			
	36	46	66	85
(ft)	lbs	lbs	lbs	lbs
31	78,4			
40	77,9	63,3		
50	72,4	60,6	40,6	
65	66,3	55,2	38,4	28,2
80	50,6	50,8	35,2	25,9
100	36,5	37,2	31,9	23,4
120	27,6	28,1	29,0	22,1
160	16,7	17,1	17,9	18,7
190	11,5	11,9	12,6	13,2
200		10,4	11,2	11,8
220			8,6	9,2
240				7,0

Main boom 191 ft

Radius	Fixed jib length in (ft)			
	36	46	66	85
(ft)	lbs	lbs	lbs	lbs
31,7	73,9			
40	72,7	60,8		
50	68,6	58,3	40,0	
65	63,2	53,5	38,5	27,9
80	50,2	49,8	35,6	26,0
120	27,0	27,6	28,8	21,8
160	16,1	16,5	17,4	18,2
200	9,6	9,9	10,6	11,3
210	8,3	8,7	9,3	10,0
220		7,5	8,2	8,8
240			6,0	6,6
255				5,2

Main boom 219 ft

Radius	Fixed jib length in (ft)			
	36	56	66	85
(ft)	lbs	lbs	lbs	lbs
32,4	66,4			
45	64,0	46,6		
55	61,0	45,6	39,6	
65	58,1	43,4	37,9	27,5
80	49,8	40,4	35,2	26,0
120	26,5	27,8	28,4	22,0
160	15,6	16,5	16,9	17,8
200	9,1	9,9	10,2	10,8
225	6,2	6,9	7,2	7,8
245		4,9	5,1	5,7
255			4,2	4,8
275				3,1

Main boom 229 ft

Radius	Fixed jib length in (ft)			
	36	46	56	66
(ft)	lbs	lbs	lbs	lbs
33	56,3			
40	56,3	49,6		
50	55,1	48,5	42,5	
55	53,9	47,7	42,2	37,1
80	48,2	42,9	38,1	33,9
120	26,0	26,6	27,3	27,9
160	15,0	15,4	16,0	16,4
200	8,5	8,9	9,3	9,6
240	4,2	4,5	4,8	5,1
250		3,6	3,9	4,2
260			3,0	3,3
270				2,5

Main boom 238 ft

Radius	Fixed jib length in (ft)			
	36	46		
(ft)	lbs	lbs		
34,2	51,9			
45	51,2	44,7		
60	48,2	43,3		
80	43,5	39,3		
100	34,9	35,4		
120	25,8	26,4		
160	14,8	15,2		
200	8,3	8,7		
220	6,0	6,3		
240	4,0	4,3		
250	3,1	3,4		
260		2,5		

TLT 10576404 - M118422

Capacities in 1000 lbs with fixed jib (No. 1008.xx), 137,400 lbs counterweight + 44,100 lbs carbody counterweight. Above lift chart is for reference only. For actual lift duty and complete chart with all available configurations please refer to lift chart in operator's cab or manual.

Liebherr-Werk Nenzing GmbH

Dr. Hans Liebherr Str. 1, 6710 Nenzing/Austria
Tel.: +43 50809 41-473, Fax: +43 50809 41-499
crawler.crane@liebherr.com, www.liebherr.com
facebook.com/LiebherrConstruction