

Mobile Crane Grue mobile

LTM 1250-6.1

Technical Data Caractéristiques techniques

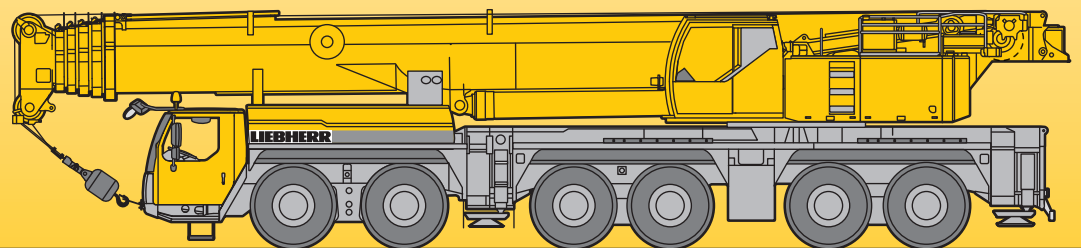

LIEBHERR

Courtesy of Crane.Market

Dimensions Encombrement

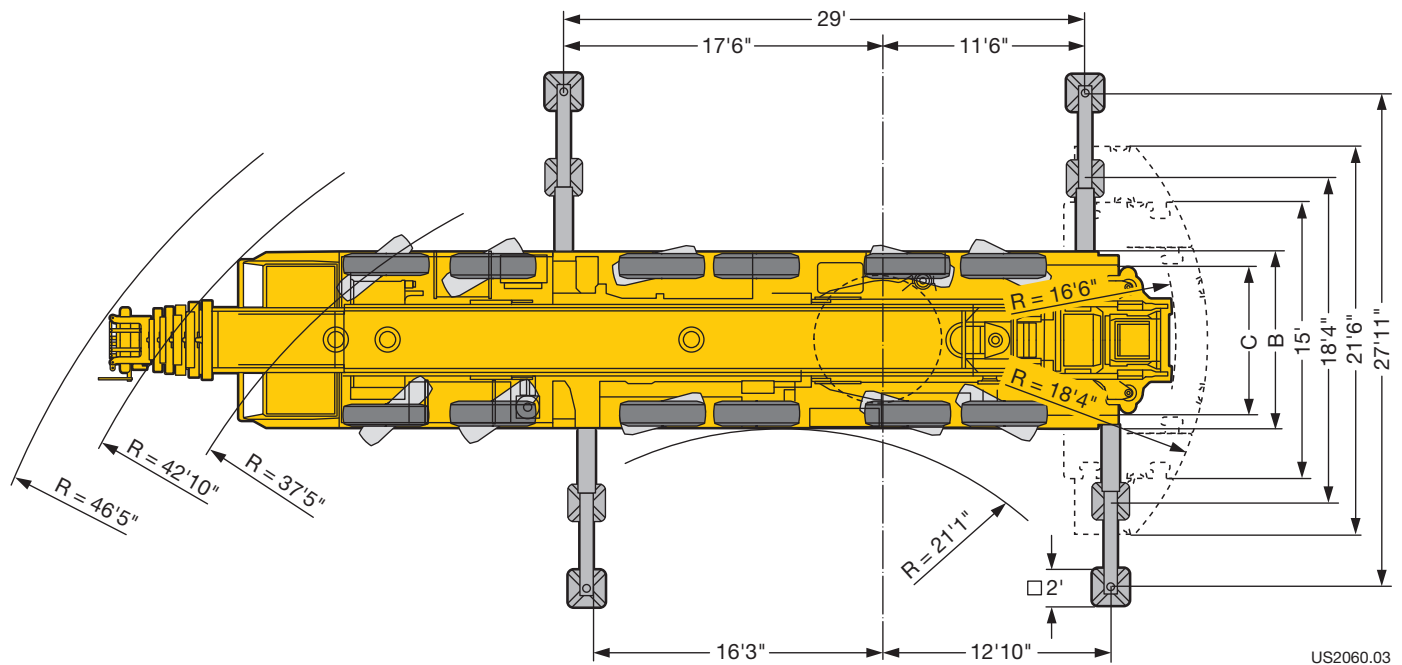
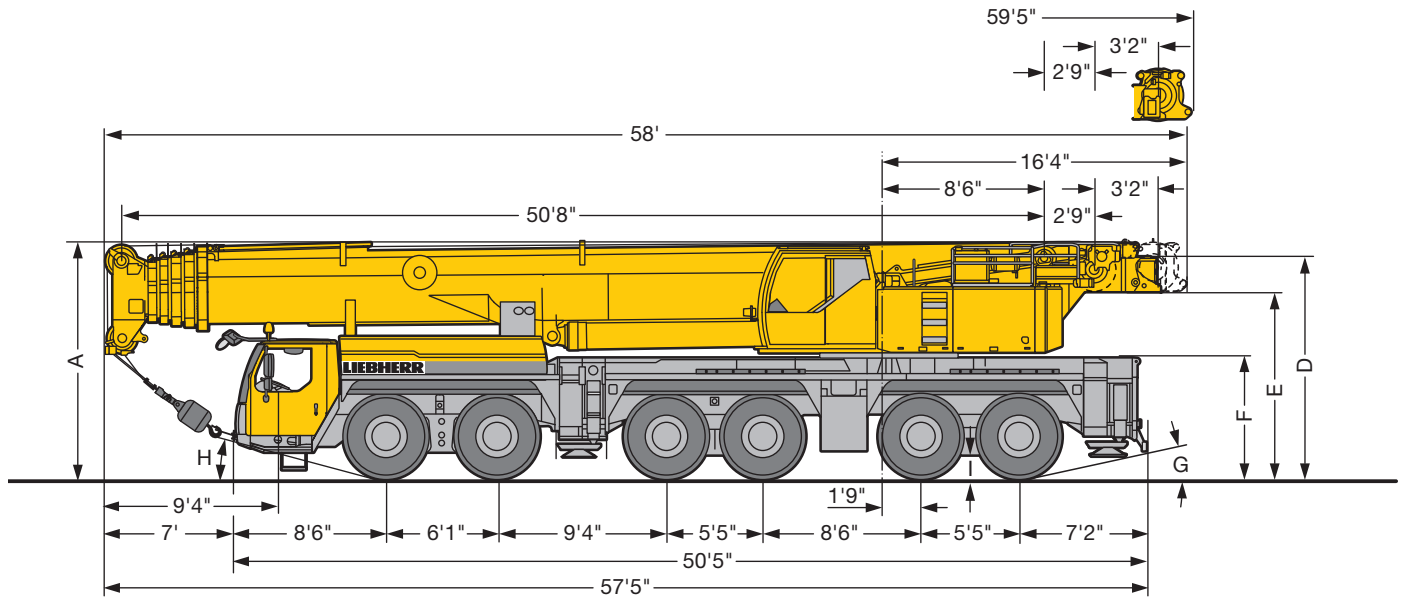

US2060.03

| Dimensions / Encombrement | | | | | | | | | | |
|---------------------------|-------|--------|-------|-------|-------|-------|------|-----|-----|------|
| | A | A | B | C | D | E | F | G | H | I |
| 445/95 R 25 (16.00 R 25) | 13'1" | 12'8"* | 9'10" | 8'4" | 12'4" | 10'4" | 6'9" | 12° | 14° | 1'3" |
| 525/80 R 25 (20.5 R 25) | 13'1" | 12'8" | 10'8" | 8'10" | 12'4" | 10'4" | 6'9" | 12° | 14° | 1'3" |

* lowered / abaissé

Weights Poids



| Axle Essieu lbs | 1 | 2 | 3 | 4 | 5 | 6 | Total weight lbs Poids total lbs |
|-----------------------|-------|-------|-------|-------|-------|-------|-------------------------------------|
| | 26400 | 26400 | 26400 | 26400 | 26400 | 26400 | 158400 |



| Load kips ¹⁾ Forces de levage kips ¹⁾ | No. of sheaves Poulies | No. of lines Brins | Weight lbs Poids lbs |
|--|---------------------------|-----------------------|-------------------------|
| 388 | 9 | 19 | 5290 |
| 315 | 7 | 14 | 3750 |
| 238 | 5 | 10 | 3200 |
| 156 | 3 | 6 | 2290 |
| 69 | 1 | 3 | 1850 |
| 22 | – | 1 | 1100 |





¹⁾ The safety regulations of the respective country shall be applicable.
Les spécifications de sécurité du pays concerné seront en vigueur.

Working speeds Vitesses







| | | 1 | 2 | 3 | 4 | 5 | 6 | 7 | 8 | 9 | 10 | 11 | 12 | R 1 | R 2 | | |
|---|---|---|-----|-----|-----|-----|-----|------|------|------|------|------|------|-----|-----|-----|---|
|  | 445/95 R 25 (16.00 R 25) 525/80 R 25 (20.5 R 25) |  | 3.5 | 4.5 | 5.8 | 7.5 | 9.5 | 12.8 | 16.1 | 20.6 | 26.7 | 34.2 | 43.4 | 50 | 3.8 | 4.9 |  |
| | | | | | | | | | | | | | | | | | 47.9 % |



| Drive Mécanismes | infinitely variable en continu | Rope diameter / Rope length Diamètre du câble / Longueur du câble | Max. single line pull Effort au brin maxi. |
|---|--|--|---|
|  | 0 – 427 ft/min single line ft/min au brin simple | 0.9" / 1181' | 23605 lbs |
|  | 0 – 492 ft/min single line ft/min au brin simple | 0.9" / 1378' | 23605 lbs |
|  | 0 – 1.6 rpm | | |
|  | approx. 60 seconds to reach 82° boom angle env. 60 s jusqu'à 82° | | |
|  | approx. 600 seconds for boom extension from 51 ft – 236 ft env. 600 s pour passer de 51 ft – 236 ft | | |

Lifting capacities Forces de levage

T

51 - 236 ft    214900 lbs  **85%**





| ft | 51 ft | | 68 ft | 85 ft | 102 ft | 119 ft | 136 ft | 153 ft | 170 ft | 187 ft | 204 ft | 221 ft | 236 ft | ft |
|-----|-------|-----|-------|-------|--------|--------|--------|--------|--------|--------|--------|--------|--------|-----|
| | * | | | | | | | | | | | | | |
| 9 | | 389 | | | | | | | | | | | | 9 |
| 10 | 585 | 388 | 297 | | | | | | | | | | | 10 |
| 12 | 370 | 370 | 297 | 258 | | | | | | | | | | 12 |
| 14 | 331 | 331 | 297 | 258 | | | | | | | | | | 14 |
| 16 | 305 | 305 | 284 | 258 | 197 | | | | | | | | | 16 |
| 18 | 286 | 286 | 268 | 250 | 197 | 157 | | | | | | | | 18 |
| 21 | 261 | 261 | 246 | 232 | 197 | 157 | 134 | | | | | | | 21 |
| 24 | 239 | 239 | 226 | 214 | 195 | 157 | 134 | 104 | | | | | | 24 |
| 27 | 220 | 220 | 209 | 198 | 188 | 157 | 134 | 104 | 81.5 | | | | | 27 |
| 30 | 201 | 201 | 195 | 184 | 175 | 157 | 132 | 102 | 81.5 | 63.5 | | | | 30 |
| 33 | 183 | 183 | 182 | 172 | 164 | 156 | 130 | 97.5 | 81 | 63.5 | | | | 33 |
| 36 | 163 | 163 | 170 | 162 | 154 | 150 | 129 | 93.5 | 79 | 63.5 | 46.3 | | | 36 |
| 39 | 142 | 142 | 158 | 153 | 145 | 141 | 124 | 89.5 | 76.5 | 63.5 | 46.3 | 41.3 | | 39 |
| 45 | | | 137 | 136 | 130 | 127 | 113 | 82 | 71.5 | 60.5 | 46.3 | 41.1 | | 45 |
| 51 | | | 116 | 121 | 117 | 115 | 104 | 74.5 | 66 | 57.4 | 46.3 | 40.8 | 34 | 51 |
| 57 | | | 77.5 | 107 | 105 | 104 | 96 | 68 | 60.5 | 53.6 | 46 | 39.8 | 33.8 | 57 |
| 63 | | | | 93 | 94.5 | 95 | 89 | 63 | 55.7 | 49.9 | 44 | 38.5 | 33.2 | 63 |
| 69 | | | | 79 | 84 | 86 | 82.5 | 59.2 | 51 | 46.4 | 41.3 | 36.9 | 32.3 | 69 |
| 75 | | | | | 75 | 78.5 | 76.5 | 56.1 | 46.9 | 43.2 | 38.8 | 35.1 | 31 | 75 |
| 81 | | | | | 67 | 72.5 | 71 | 53.2 | 43.7 | 40 | 36.4 | 33.2 | 29.4 | 81 |
| 87 | | | | | 59.1 | 67 | 65 | 50.5 | 40.9 | 37 | 34.2 | 31.4 | 27.9 | 87 |
| 93 | | | | | | 61 | 59.4 | 48 | 38.4 | 34.5 | 32.1 | 29.8 | 26.4 | 93 |
| 99 | | | | | | 53.8 | 54.3 | 45.6 | 36.1 | 32.1 | 30.1 | 28.2 | 25.1 | 99 |
| 105 | | | | | | | 49.9 | 44 | 33.8 | 30.3 | 28.3 | 26.6 | 23.7 | 105 |
| 111 | | | | | | | 45.9 | 42.4 | 32 | 28.6 | 26.5 | 25.1 | 22.5 | 111 |
| 117 | | | | | | | 40.7 | 40.9 | 30.7 | 27 | 25 | 23.8 | 21.3 | 117 |
| 123 | | | | | | | 36.7 | 39.5 | 29.5 | 25.4 | 23.6 | 22.4 | 20.1 | 123 |
| 129 | | | | | | | | 36.9 | 28.4 | 24.1 | 22.4 | 21.1 | 19 | 129 |
| 135 | | | | | | | | 33.6 | 27.4 | 22.9 | 21.2 | 19.8 | 17.9 | 135 |
| 141 | | | | | | | | 23.9 | 26.3 | 21.8 | 20.1 | 18.6 | 16.9 | 141 |
| 147 | | | | | | | | | 25.4 | 20.8 | 19.3 | 17.4 | 15.9 | 147 |
| 153 | | | | | | | | | 24.4 | 19.8 | 18.4 | 16.3 | 14.9 | 153 |
| 159 | | | | | | | | | | 19 | 17.7 | 15.4 | 14 | 159 |
| 165 | | | | | | | | | | 18.3 | 16.9 | 14.6 | 13.3 | 165 |
| 171 | | | | | | | | | | 17.7 | 16.2 | 13.7 | 12.6 | 171 |
| 177 | | | | | | | | | | 14.7 | 15.5 | 12.9 | 11.9 | 177 |
| 183 | | | | | | | | | | | 14.8 | 12.2 | 11.2 | 183 |
| 189 | | | | | | | | | | | | 11.4 | 10.5 | 189 |
| 195 | | | | | | | | | | | | 10.7 | 9.8 | 195 |
| 201 | | | | | | | | | | | | 10 | 9.2 | 201 |
| 207 | | | | | | | | | | | | | 8.5 | 207 |
| 213 | | | | | | | | | | | | | 7.9 | 213 |

* over rear · en arrière

TAB 131201 / 131351

Lifting capacities Forces de levage

T





51 - 236 ft  T   360°  187400 lbs  85%

| ft | 51 ft | 68 ft | 85 ft | 102 ft | 119 ft | 136 ft | 153 ft | 170 ft | 187 ft | 204 ft | 221 ft | 236 ft | ft |
|-----|-------|-------|-------|--------|--------|--------|--------|--------|--------|--------|--------|--------|-----|
| 9 | 389 | | | | | | | | | | | | 9 |
| 10 | 388 | 297 | | | | | | | | | | | 10 |
| 12 | 370 | 297 | 258 | | | | | | | | | | 12 |
| 14 | 331 | 297 | 258 | | | | | | | | | | 14 |
| 16 | 305 | 284 | 258 | 197 | | | | | | | | | 16 |
| 18 | 286 | 268 | 250 | 197 | 157 | | | | | | | | 18 |
| 21 | 261 | 246 | 232 | 197 | 157 | 134 | | | | | | | 21 |
| 24 | 239 | 226 | 214 | 195 | 157 | 134 | 104 | | | | | | 24 |
| 27 | 220 | 209 | 198 | 188 | 157 | 134 | 104 | 81.5 | | | | | 27 |
| 30 | 201 | 195 | 184 | 175 | 157 | 132 | 102 | 81.5 | 63.5 | | | | 30 |
| 33 | 183 | 182 | 172 | 164 | 156 | 130 | 97.5 | 81 | 63.5 | | | | 33 |
| 36 | 163 | 170 | 162 | 154 | 150 | 129 | 93.5 | 79 | 63.5 | 46.3 | | | 36 |
| 39 | 142 | 158 | 153 | 145 | 141 | 124 | 89.5 | 76.5 | 63.5 | 46.3 | 41.3 | | 39 |
| 45 | | 137 | 136 | 130 | 127 | 113 | 82 | 71.5 | 60.5 | 46.3 | 41.1 | | 45 |
| 51 | | 116 | 119 | 116 | 115 | 104 | 74.5 | 66 | 57.4 | 46.3 | 40.8 | 34 | 51 |
| 57 | | 77.5 | 103 | 102 | 103 | 96 | 68 | 60.5 | 53.6 | 46 | 39.8 | 33.8 | 57 |
| 63 | | | 90.5 | 89 | 91.5 | 89 | 63 | 55.7 | 49.9 | 44 | 38.5 | 33.2 | 63 |
| 69 | | | 78.5 | 78.5 | 83 | 82 | 59.2 | 51 | 46.4 | 41.3 | 36.9 | 32.3 | 69 |
| 75 | | | | 70.5 | 76.5 | 74.5 | 56.1 | 46.9 | 43.2 | 38.8 | 35.1 | 31 | 75 |
| 81 | | | | 64.5 | 69 | 67 | 53.2 | 43.7 | 40 | 36.4 | 33.2 | 29.4 | 81 |
| 87 | | | | 59.1 | 63 | 61 | 50.5 | 40.9 | 37 | 34.2 | 31.4 | 27.9 | 87 |
| 93 | | | | | 57.3 | 55.2 | 48 | 38.4 | 34.5 | 32.1 | 29.8 | 26.4 | 93 |
| 99 | | | | | 52.4 | 50.2 | 45.6 | 36.1 | 32.1 | 30.1 | 28.2 | 25.1 | 99 |
| 105 | | | | | | 45.8 | 44 | 33.8 | 30.3 | 28.3 | 26.6 | 23.7 | 105 |
| 111 | | | | | | 42 | 42.4 | 32 | 28.6 | 26.5 | 25.1 | 22.5 | 111 |
| 117 | | | | | | 38.6 | 40.3 | 30.7 | 27 | 25 | 23.8 | 21.3 | 117 |
| 123 | | | | | | 36.2 | 37.4 | 29.5 | 25.4 | 23.6 | 22.4 | 20.1 | 123 |
| 129 | | | | | | | 34.6 | 28.4 | 24.1 | 22.4 | 21.1 | 19 | 129 |
| 135 | | | | | | | 32.2 | 27.4 | 22.9 | 21.2 | 19.8 | 17.9 | 135 |
| 141 | | | | | | | 23.3 | 26.3 | 21.8 | 20.1 | 18.6 | 16.9 | 141 |
| 147 | | | | | | | | 25.4 | 20.8 | 19.3 | 17.4 | 15.9 | 147 |
| 153 | | | | | | | | 24.4 | 19.8 | 18.4 | 16.3 | 14.9 | 153 |
| 159 | | | | | | | | | 19 | 17.7 | 15.4 | 14 | 159 |
| 165 | | | | | | | | | 18.3 | 16.9 | 14.6 | 13.3 | 165 |
| 171 | | | | | | | | | 17.7 | 16.2 | 13.7 | 12.6 | 171 |
| 177 | | | | | | | | | 14.7 | 15.5 | 12.9 | 11.9 | 177 |
| 183 | | | | | | | | | | 14.8 | 12.2 | 11.2 | 183 |
| 189 | | | | | | | | | | | 11.4 | 10.5 | 189 |
| 195 | | | | | | | | | | | 10.7 | 9.8 | 195 |
| 201 | | | | | | | | | | | 10 | 9.2 | 201 |
| 207 | | | | | | | | | | | | 8.5 | 207 |
| 213 | | | | | | | | | | | | 7.9 | 213 |

TAB 131352

Lifting capacities Forces de levage

T





51 - 236 ft    159800 lbs  **85%**

| ft | 51 ft | 68 ft | 85 ft | 102 ft | 119 ft | 136 ft | 153 ft | 170 ft | 187 ft | 204 ft | 221 ft | 236 ft | ft |
|-----|-------|-------|-------|--------|--------|--------|--------|--------|--------|--------|--------|--------|-----|
| 9 | 389 | | | | | | | | | | | | 9 |
| 10 | 388 | 297 | | | | | | | | | | | 10 |
| 12 | 370 | 297 | 258 | | | | | | | | | | 12 |
| 14 | 331 | 297 | 258 | | | | | | | | | | 14 |
| 16 | 305 | 284 | 258 | 197 | | | | | | | | | 16 |
| 18 | 286 | 268 | 250 | 197 | 157 | | | | | | | | 18 |
| 21 | 261 | 246 | 232 | 197 | 157 | 134 | | | | | | | 21 |
| 24 | 239 | 226 | 214 | 195 | 157 | 134 | 104 | | | | | | 24 |
| 27 | 220 | 209 | 198 | 188 | 157 | 134 | 104 | 81.5 | | | | | 27 |
| 30 | 201 | 195 | 184 | 175 | 157 | 132 | 102 | 81.5 | 63.5 | | | | 30 |
| 33 | 183 | 182 | 172 | 164 | 156 | 130 | 97.5 | 81 | 63.5 | | | | 33 |
| 36 | 163 | 169 | 162 | 154 | 150 | 129 | 93.5 | 79 | 63.5 | 46.3 | | | 36 |
| 39 | 142 | 155 | 153 | 145 | 141 | 124 | 89.5 | 76.5 | 63.5 | 46.3 | 41.3 | | 39 |
| 45 | | 130 | 130 | 127 | 127 | 113 | 82 | 71.5 | 60.5 | 46.3 | 41.1 | | 45 |
| 51 | | 113 | 111 | 109 | 110 | 104 | 74.5 | 66 | 57.4 | 46.3 | 40.8 | 34 | 51 |
| 57 | | 77 | 96 | 94.5 | 97.5 | 94.5 | 68 | 60.5 | 53.6 | 46 | 39.8 | 33.8 | 57 |
| 63 | | | 84 | 82.5 | 88 | 84 | 63 | 55.7 | 49.9 | 44 | 38.5 | 33.2 | 63 |
| 69 | | | 74 | 74.5 | 79 | 74.5 | 59.2 | 51 | 46.4 | 41.3 | 36.9 | 32.3 | 69 |
| 75 | | | | 69 | 70.5 | 66.5 | 56.1 | 46.9 | 43.2 | 38.8 | 35.1 | 31 | 75 |
| 81 | | | | 64 | 63 | 59.7 | 53.2 | 43.7 | 40 | 36.4 | 33.2 | 29.4 | 81 |
| 87 | | | | 57.5 | 56.9 | 53.9 | 50.5 | 40.9 | 37 | 34.2 | 31.4 | 27.9 | 87 |
| 93 | | | | | 51.3 | 48.9 | 48 | 38.4 | 34.5 | 32.1 | 29.8 | 26.4 | 93 |
| 99 | | | | | 46.4 | 44.4 | 45.5 | 36.1 | 32.1 | 30.1 | 28.2 | 25.1 | 99 |
| 105 | | | | | | 41.5 | 41.9 | 33.8 | 30.3 | 28.3 | 26.6 | 23.7 | 105 |
| 111 | | | | | | 39.8 | 38.3 | 32 | 28.6 | 26.5 | 25.1 | 22.5 | 111 |
| 117 | | | | | | 37 | 34.9 | 30.7 | 27 | 25 | 23.8 | 21.3 | 117 |
| 123 | | | | | | 34 | 31.8 | 29.5 | 25.4 | 23.6 | 22.4 | 20.1 | 123 |
| 129 | | | | | | | 29.1 | 28.4 | 24.1 | 22.4 | 21.1 | 19 | 129 |
| 135 | | | | | | | 26.6 | 27.2 | 22.9 | 21.2 | 19.8 | 17.9 | 135 |
| 141 | | | | | | | 20.5 | 25.4 | 21.8 | 20.1 | 18.6 | 16.9 | 141 |
| 147 | | | | | | | | 23.3 | 20.8 | 19.3 | 17.4 | 15.9 | 147 |
| 153 | | | | | | | | 21.5 | 19.8 | 18.4 | 16.3 | 14.9 | 153 |
| 159 | | | | | | | | | 19 | 17.7 | 15.4 | 14 | 159 |
| 165 | | | | | | | | | 18.1 | 16.9 | 14.6 | 13.3 | 165 |
| 171 | | | | | | | | | 16.7 | 16.1 | 13.7 | 12.6 | 171 |
| 177 | | | | | | | | | 14.7 | 14.8 | 12.9 | 11.9 | 177 |
| 183 | | | | | | | | | | 13.6 | 11.8 | 11.2 | 183 |
| 189 | | | | | | | | | | | 10.7 | 10.5 | 189 |
| 195 | | | | | | | | | | | 9.6 | 9.6 | 195 |
| 201 | | | | | | | | | | | 8.6 | 8.6 | 201 |
| 207 | | | | | | | | | | | | 7.6 | 207 |
| 213 | | | | | | | | | | | | 6.8 | 213 |

TAB 131353

Lifting capacities Forces de levage

T

|      | | | | | | | | | | | | | |
|---|-------|-------|-------|--------|--------|--------|--------|--------|--------|--------|--------|--------|-----|
| ft | 51 ft | 68 ft | 85 ft | 102 ft | 119 ft | 136 ft | 153 ft | 170 ft | 187 ft | 204 ft | 221 ft | 236 ft | ft |
| 9 | 389 | | | | | | | | | | | | 9 |
| 10 | 388 | 297 | | | | | | | | | | | 10 |
| 12 | 370 | 297 | 258 | | | | | | | | | | 12 |
| 14 | 331 | 297 | 258 | | | | | | | | | | 14 |
| 16 | 305 | 284 | 258 | 197 | | | | | | | | | 16 |
| 18 | 277 | 256 | 234 | 192 | 157 | | | | | | | | 18 |
| 21 | 231 | 212 | 191 | 171 | 149 | 133 | | | | | | | 21 |
| 24 | 185 | 169 | 153 | 139 | 131 | 126 | 103 | | | | | | 24 |
| 27 | 149 | 142 | 131 | 128 | 117 | 107 | 99 | 80.5 | | | | | 27 |
| 30 | 123 | 121 | 116 | 109 | 101 | 94.5 | 89.5 | 79.5 | 63.5 | | | | 30 |
| 33 | 104 | 104 | 100 | 94.5 | 87.5 | 86 | 78.5 | 72 | 63 | | | | 33 |
| 36 | 89.5 | 90 | 87.5 | 83 | 78 | 76 | 71.5 | 67.5 | 62 | 46.3 | | | 36 |
| 39 | 78 | 79 | 77.5 | 74.5 | 69 | 68 | 65.5 | 61 | 56.4 | 46.3 | 41.3 | | 39 |
| 45 | | 63 | 62 | 62 | 55.8 | 57.4 | 54.3 | 51.7 | 48.1 | 44.4 | 40.6 | 33.9 | 45 |
| 51 | | 50.8 | 51 | 51.6 | 49.3 | 48.6 | 45.9 | 43.8 | 40.4 | 37.8 | 34.2 | 32 | 51 |
| 57 | | 41 | 42.5 | 43.4 | 42.1 | 41 | 38.8 | 36.8 | 33.7 | 31.4 | 28.1 | 27.3 | 57 |
| 63 | | | 35.8 | 36.7 | 35.7 | 34.8 | 32.9 | 31.1 | 28.3 | 26.2 | 23.2 | 22.5 | 63 |
| 69 | | | 29.8 | 31.3 | 30.4 | 29.8 | 28 | 26.4 | 23.8 | 21.9 | 19.1 | 18.6 | 69 |
| 75 | | | | 26.9 | 26.1 | 25.6 | 24 | 22.5 | 20.1 | 18.4 | 15.7 | 15.3 | 75 |
| 81 | | | | 23.1 | 22.5 | 22.1 | 20.6 | 19.3 | 17 | 15.3 | 12.8 | 12.4 | 81 |
| 87 | | | | 19.6 | 19.5 | 19.2 | 17.7 | 16.5 | 14.3 | 12.8 | 10.3 | 10 | 87 |
| 93 | | | | | 16.8 | 16.7 | 15.2 | 14.1 | 12 | 10.5 | 8.1 | 7.8 | 93 |
| 99 | | | | | 14.3 | 14.5 | 13.1 | 12 | 9.9 | 8.5 | | | 99 |
| 105 | | | | | | 12.5 | 11.2 | 10.2 | 8.2 | | | | 105 |
| 111 | | | | | | 10.6 | 9.6 | 8.6 | 6.6 | | | | 111 |
| 117 | | | | | | 9 | 8.1 | 7.1 | 5.2 | | | | 117 |
| 123 | | | | | | 7.6 | 6.7 | 5.9 | | | | | 123 |
| 129 | | | | | | | 5.3 | 4.8 | | | | | 129 |
| 135 | | | | | | | 4.2 | | | | | | 135 |

TAB 131329

Lifting heights Hauteurs de levage

T

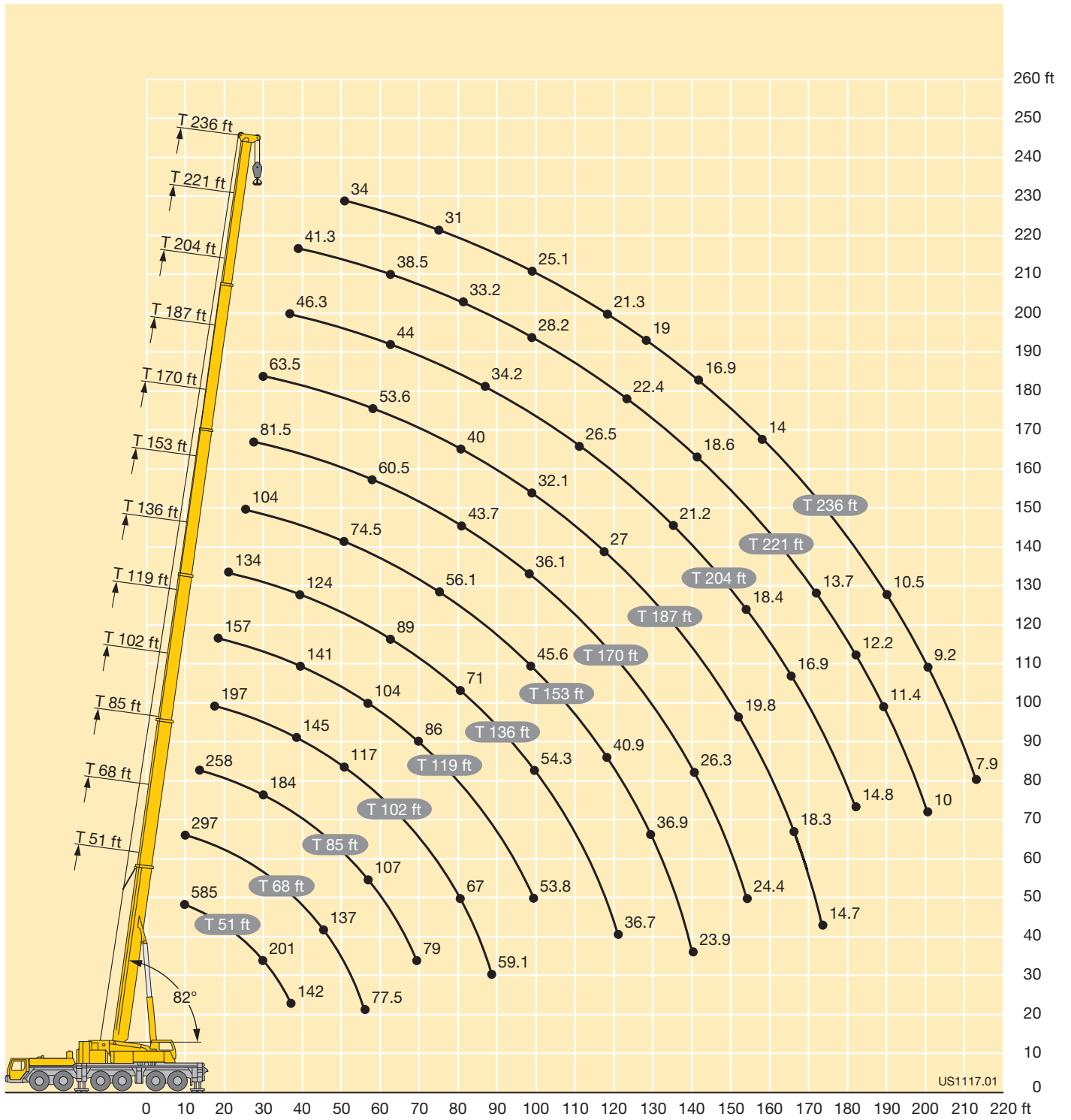

Lifting capacities Forces de levage

TK



| ft | 51 ft | | | 68 ft | | | 85 ft | | | 102 ft | | | 119 ft | | | 136 ft | | | ft |
|-----|-------|------|------|-------|------|------|-------|------|------|--------|------|------|--------|------|------|--------|------|------|-----|
| | 18 ft | | | 18 ft | | | 18 ft | | | 18 ft | | | 18 ft | | | 18 ft | | | |
| | 0° | 20° | 40° | 0° | 20° | 40° | 0° | 20° | 40° | 0° | 20° | 40° | 0° | 20° | 40° | 0° | 20° | 40° | |
| 10 | 135 | 108 | | | | | | | | | | | | | | | | | 10 |
| 12 | 135 | 107 | | 135 | 105 | | | | | | | | | | | | | | 12 |
| 14 | 132 | 102 | 84 | 135 | 104 | | | | | | | | | | | | | | 14 |
| 16 | 125 | 98.5 | 82.5 | 131 | 101 | 83.5 | 129 | 101 | | | | | | | | | | | 16 |
| 18 | 120 | 95 | 80.5 | 126 | 98 | 82.5 | 126 | 98.5 | 82.5 | | 96 | | | | | | | | 18 |
| 21 | 112 | 90 | 77.5 | 119 | 94 | 80 | 120 | 95 | 81 | 113 | 95 | 79 | | 91 | | | | | 21 |
| 24 | 105 | 86 | 75 | 112 | 90 | 77.5 | 114 | 91.5 | 79 | 112 | 92 | 78.5 | 108 | 90.5 | 77.5 | | | | 24 |
| 27 | 98.5 | 82 | 72.5 | 106 | 86.5 | 75.5 | 110 | 88.5 | 77 | 109 | 89 | 77.5 | 105 | 88 | 77 | 91 | 80 | | 27 |
| 30 | 93 | 78.5 | 70.5 | 101 | 83 | 73.5 | 105 | 85.5 | 75 | 105 | 86.5 | 76 | 102 | 86 | 76 | 90 | 80 | 71.5 | 30 |
| 33 | 88 | 75.5 | 68.5 | 96.5 | 80 | 72 | 100 | 82.5 | 73 | 102 | 84 | 74 | 99.5 | 84 | 74.5 | 88 | 78.5 | 71.5 | 33 |
| 36 | 84 | 73 | 66.5 | 92 | 77.5 | 70.5 | 96.5 | 80 | 71.5 | 98 | 81.5 | 72.5 | 97 | 82 | 73 | 86.5 | 77 | 70.5 | 36 |
| 39 | 80 | 70 | 64 | 88.5 | 75.5 | 69 | 93 | 78 | 70 | 95 | 79.5 | 71.5 | 94.5 | 80 | 72 | 85 | 75.5 | 69.5 | 39 |
| 45 | 71.5 | 63 | 60 | 82 | 71 | 65 | 87 | 74 | 67.5 | 89 | 76 | 69 | 90 | 77 | 69.5 | 82.5 | 73 | 67.5 | 45 |
| 51 | 63 | 58.6 | 31.6 | 76 | 66 | 61.5 | 81.5 | 71 | 65 | 84 | 72.5 | 66.5 | 85.5 | 74 | 68 | 79.5 | 71 | 66 | 51 |
| 57 | 55.7 | 22.7 | | 70 | 62 | 58.8 | 77 | 67.5 | 62 | 79.5 | 69.5 | 65 | 82 | 71.5 | 66 | 75.5 | 68.5 | 64.5 | 57 |
| 63 | | | | 64 | 58.3 | 37.1 | 72.5 | 63.5 | 59.6 | 76 | 67 | 63 | 79 | 69.5 | 64.5 | 71.5 | 65 | 62 | 63 |
| 69 | | | | 58 | 39.6 | 16.4 | 68 | 60.5 | 58 | 72.5 | 64.5 | 61 | 76 | 67.5 | 63 | 67.5 | 62 | 59.4 | 69 |
| 75 | | | | | | | 63.5 | 58.1 | 42.8 | 68.5 | 62 | 59 | 71.5 | 65.5 | 61.5 | 64.5 | 59.5 | 57.1 | 75 |
| 81 | | | | | | | 59.1 | 56 | 20.1 | 63.5 | 59.5 | 57.4 | 65 | 63 | 59.8 | 61.5 | 57.1 | 55.1 | 81 |
| 87 | | | | | | | 54.1 | 46.5 | | 57.4 | 56.6 | 48.1 | 58.6 | 59.2 | 57.7 | 58.3 | 54.9 | 53.3 | 87 |
| 93 | | | | | | | | | | 51.8 | 52.3 | 22.3 | 53 | 53.6 | 53.9 | 54.7 | 52.8 | 51.6 | 93 |
| 99 | | | | | | | | | | 46.8 | 45.4 | 16.7 | 48 | 48.5 | 47.9 | 49.7 | 50.3 | 49.8 | 99 |
| 105 | | | | | | | | | | | | | 43.6 | 44 | 35.2 | 45.3 | 45.8 | 46 | 105 |
| 111 | | | | | | | | | | | | | 39.8 | 40.1 | 21.9 | 41.4 | 41.9 | 42 | 111 |
| 117 | | | | | | | | | | | | | 36.4 | 36.6 | 12.9 | 38 | 38.3 | 38.5 | 117 |
| 123 | | | | | | | | | | | | | 31.6 | 26.6 | 7.6 | 34.9 | 35.2 | 27 | 123 |
| 129 | | | | | | | | | | | | | | | | 32.1 | 32.3 | 16.8 | 129 |
| 135 | | | | | | | | | | | | | | | | 29.7 | 26.8 | 10.7 | 135 |
| 141 | | | | | | | | | | | | | | | | 22.4 | | | 141 |

TAB 131430 / 131492 / 131489

Lifting capacities Forces de levage

TK



| ft | 153 ft | | | 170 ft | | | 187 ft | | | 204 ft | | | 221 ft | | | 236 ft | | | ft |
|-----|--------|------|------|--------|------|------|--------|------|------|--------|------|------|--------|------|------|--------|------|------|-----|
| | 18 ft | | | 18 ft | | | 18 ft | | | 18 ft | | | 18 ft | | | 18 ft | | | |
| | 0° | 20° | 40° | 0° | 20° | 40° | 0° | 20° | 40° | 0° | 20° | 40° | 0° | 20° | 40° | 0° | 20° | 40° | |
| 30 | 77.5 | 72.5 | | | | | | | | | | | | | | | | | 30 |
| 33 | 77.5 | 72 | | 62 | | | | | | | | | | | | | | | 33 |
| 36 | 77 | 71.5 | 67 | 62 | 62 | | 46.3 | | | | | | | | | | | | 36 |
| 39 | 76 | 70.5 | 66 | 62 | 62 | 60.5 | 46.3 | 46.3 | | | | | | | | | | | 39 |
| 45 | 71.5 | 68.5 | 65 | 59.9 | 60 | 59.9 | 46.3 | 46.3 | 46.3 | 38.8 | 38.8 | | | | | | | | 45 |
| 51 | 66 | 65.5 | 63.5 | 56.9 | 57.2 | 56.8 | 46.3 | 46.3 | 46.3 | 38.8 | 38.8 | 38.8 | 31.5 | 31.5 | | 23.4 | 23.4 | | 51 |
| 57 | 61 | 61 | 60.5 | 53.1 | 53.3 | 53.4 | 45.2 | 45.6 | 45.8 | 38.4 | 38.4 | 38.3 | 31.5 | 31.5 | 31.5 | 23.4 | 23.4 | 23.4 | 57 |
| 63 | 55.9 | 55.8 | 56.1 | 49.4 | 49.5 | 49.9 | 42.8 | 43.3 | 43.6 | 37 | 37 | 37.2 | 31.2 | 31.1 | 31.1 | 23.4 | 23.4 | 23.4 | 63 |
| 69 | 51.2 | 51.2 | 51.6 | 45.9 | 46 | 46.3 | 40.1 | 40.4 | 40.7 | 35.1 | 35.3 | 35.4 | 30.3 | 30.2 | 30.3 | 23.4 | 23.4 | 23.4 | 69 |
| 75 | 47.1 | 47.1 | 47.4 | 42.5 | 42.7 | 42.9 | 37.6 | 37.8 | 38.1 | 33 | 33.5 | 33.5 | 29 | 29 | 29.1 | 23.3 | 23.3 | 23.4 | 75 |
| 81 | 43.6 | 43.7 | 43.7 | 39.2 | 39.5 | 39.7 | 35.2 | 35.4 | 35.7 | 31.1 | 31.6 | 31.7 | 27.6 | 27.6 | 27.8 | 22.8 | 22.8 | 23 | 81 |
| 87 | 40.5 | 40.6 | 40.5 | 36.2 | 36.4 | 36.7 | 32.9 | 33.1 | 33.4 | 29.3 | 29.7 | 29.9 | 26.2 | 26.3 | 26.5 | 21.8 | 21.8 | 22.1 | 87 |
| 93 | 37.5 | 37.6 | 37.6 | 33.7 | 33.9 | 34.1 | 30.7 | 30.9 | 31.1 | 27.7 | 27.9 | 28.1 | 24.9 | 25 | 25.2 | 20.9 | 20.9 | 21.1 | 93 |
| 99 | 34.8 | 34.9 | 34.9 | 31.2 | 31.5 | 31.7 | 28.7 | 28.9 | 29.1 | 26.1 | 26.2 | 26.5 | 23.6 | 23.8 | 24 | 20 | 20.1 | 20.3 | 99 |
| 105 | 32.2 | 32.3 | 32.4 | 29 | 29.2 | 29.4 | 26.7 | 26.9 | 27.2 | 24.5 | 24.7 | 24.9 | 22.3 | 22.6 | 22.9 | 19.1 | 19.2 | 19.4 | 105 |
| 111 | 29.7 | 29.8 | 30 | 26.9 | 27.1 | 27.3 | 24.9 | 25.1 | 25.3 | 23 | 23.2 | 23.4 | 21.2 | 21.4 | 21.7 | 18.3 | 18.5 | 18.6 | 111 |
| 117 | 27.8 | 28 | 28.1 | 24.9 | 25.1 | 25.3 | 23.1 | 23.3 | 23.5 | 21.6 | 21.7 | 21.9 | 19.9 | 20.2 | 20.4 | 17.4 | 17.6 | 17.8 | 117 |
| 123 | 26.1 | 26.2 | 26.4 | 23 | 23.2 | 23.3 | 21.5 | 21.7 | 21.9 | 20.2 | 20.3 | 20.5 | 18.8 | 19 | 19.2 | 16.4 | 16.6 | 16.9 | 123 |
| 129 | 24.5 | 24.6 | 24.8 | 21.5 | 21.6 | 21.7 | 19.9 | 20.1 | 20.2 | 18.8 | 19 | 19.1 | 17.7 | 17.9 | 18.1 | 15.5 | 15.7 | 15.9 | 129 |
| 135 | 23 | 23.1 | 23.2 | 20.1 | 20.3 | 20.3 | 18.4 | 18.6 | 18.7 | 17.6 | 17.7 | 17.8 | 16.7 | 16.8 | 17 | 14.5 | 14.7 | 14.9 | 135 |
| 141 | 21.5 | 21.6 | 19.2 | 18.8 | 19 | 19 | 17 | 17.2 | 17.3 | 16.5 | 16.6 | 16.7 | 15.6 | 15.8 | 16 | 13.7 | 13.8 | 14 | 141 |
| 147 | 20.1 | 20.2 | 13.5 | 17.6 | 17.7 | 17.7 | 15.9 | 16.1 | 16.2 | 15.6 | 15.6 | 15.7 | 14.6 | 14.8 | 14.9 | 12.8 | 13 | 13.2 | 147 |
| 153 | 16.8 | 16.9 | 9.2 | 16.4 | 16.6 | 16.4 | 14.9 | 15 | 15.1 | 14.7 | 14.8 | 14.8 | 13.6 | 13.8 | 13.9 | 12 | 12.2 | 12.3 | 153 |
| 159 | | | | 15.3 | 15.4 | 14 | 13.8 | 14 | 14 | 14 | 14 | 14.1 | 12.6 | 12.8 | 12.9 | 11.2 | 11.4 | 11.5 | 159 |
| 165 | | | | 14.2 | 14.3 | | 12.9 | 12.9 | 13 | 13.1 | 13.3 | 13.3 | 11.7 | 11.8 | 11.9 | 10.5 | 10.6 | 10.8 | 165 |
| 171 | | | | | | | 11.9 | 12 | 12 | 12.3 | 12.4 | 12.4 | 10.9 | 11.1 | 11.2 | 9.8 | 9.9 | 10 | 171 |
| 177 | | | | | | | 11 | 11 | 11 | 11.5 | 11.6 | 11.6 | 10.2 | 10.4 | 10.4 | 9.2 | 9.3 | 9.4 | 177 |
| 183 | | | | | | | 10.1 | 10.1 | 9.8 | 10.8 | 10.8 | 10.8 | 9.5 | 9.6 | 9.7 | 8.6 | 8.8 | 8.8 | 183 |
| 189 | | | | | | | | | | 10 | 10.1 | 10 | 8.9 | 8.9 | 9 | 8.1 | 8.2 | 8.2 | 189 |
| 195 | | | | | | | | | | 9.3 | 9.4 | 9.2 | 8.2 | 8.3 | 8.3 | 7.5 | 7.7 | 7.6 | 195 |
| 201 | | | | | | | | | | 8.6 | 8.7 | 8.5 | 7.6 | 7.7 | 7.7 | 7 | 7.1 | 7.1 | 201 |
| 207 | | | | | | | | | | | | | 7 | 7 | 7 | 6.5 | 6.5 | 6.5 | 207 |
| 213 | | | | | | | | | | | | | 6.4 | 6.4 | 6.4 | 6 | 6 | 5.9 | 213 |
| 219 | | | | | | | | | | | | | 5.8 | | | 5.4 | 5.5 | 5.4 | 219 |
| 225 | | | | | | | | | | | | | | | | 4.9 | 5 | 4.8 | 225 |
| 231 | | | | | | | | | | | | | | | | 4.4 | 4.5 | | 231 |

TAB 131430 / 131492 / 131489

Lifting capacities Forces de levage

TK



| ft | 51 ft | | | 170 ft | | | 187 ft | | | 204 ft | | | 221 ft | | | 236 ft | | | ft |
|-----|-------|------|------|--------|------|------|--------|------|------|--------|------|------|--------|------|------|--------|------|------|-----|
| | 40 ft | | | 40 ft | | | 40 ft | | | 40 ft | | | 40 ft | | | 40 ft | | | |
| | 0° | 20° | 40° | 0° | 20° | 40° | 0° | 20° | 40° | 0° | 20° | 40° | 0° | 20° | 40° | 0° | 20° | 40° | |
| 11 | 40 | | | | | | | | | | | | | | | | | | 11 |
| 12 | 39.8 | | | | | | | | | | | | | | | | | | 12 |
| 13 | 39.4 | | | | | | | | | | | | | | | | | | 13 |
| 14 | 39.1 | | | | | | | | | | | | | | | | | | 14 |
| 15 | 38.8 | | | | | | | | | | | | | | | | | | 15 |
| 16 | 38.5 | | | | | | | | | | | | | | | | | | 16 |
| 17 | 38.2 | | | | | | | | | | | | | | | | | | 17 |
| 18 | 37.9 | 32.7 | | | | | | | | | | | | | | | | | 18 |
| 20 | 37.3 | 32.6 | | | | | | | | | | | | | | | | | 20 |
| 22 | 36.6 | 32 | | | | | | | | | | | | | | | | | 22 |
| 24 | 36 | 31.2 | | | | | | | | | | | | | | | | | 24 |
| 26 | 35.3 | 30.1 | | | | | | | | | | | | | | | | | 26 |
| 28 | 34.7 | 29.2 | 22.8 | | | | | | | | | | | | | | | | 28 |
| 30 | 33.9 | 28.3 | 22.8 | | | | | | | | | | | | | | | | 30 |
| 32 | 32.6 | 27.5 | 22.8 | 40 | | | | | | | | | | | | | | | 32 |
| 34 | 31.2 | 26.8 | 22.6 | 40 | | | | | | | | | | | | | | | 34 |
| 36 | 29.9 | 26.1 | 22.2 | 40 | | | 34.9 | | | | | | | | | | | | 36 |
| 38 | 28.6 | 25.5 | 21.8 | 39.7 | | | 34.9 | | | | | | | | | | | | 38 |
| 40 | 27.4 | 24.9 | 21.5 | 39.5 | | | 34.9 | | | | | | | | | | | | 40 |
| 45 | 24.5 | 23.5 | 20.8 | 38.9 | 32.3 | | 34.9 | | | 29.1 | | | 23.3 | | | | | | 45 |
| 50 | 22.1 | 22.5 | 20.2 | 38.3 | 31.4 | | 34.6 | 30.6 | | 29.1 | | | 23.3 | | | 19.6 | | | 50 |
| 55 | 20 | 21.3 | 19.8 | 37.6 | 30.3 | 22.8 | 34.2 | 30.1 | 22.6 | 29.1 | 27.9 | | 23.3 | | | 19.6 | | | 55 |
| 60 | 18 | 19.8 | 19.6 | 36.8 | 29.2 | 22.7 | 33.8 | 29.2 | 22.5 | 28.9 | 27.8 | | 23.3 | | | 19.6 | | | 60 |
| 65 | 16.3 | 17.8 | 18.9 | 36.2 | 28.2 | 22.3 | 33.5 | 28.3 | 22.2 | 28.7 | 27.4 | 21.6 | 23.3 | 23.3 | | 19.6 | 19.6 | | 65 |
| 70 | 14.9 | 16.1 | 17 | 35.5 | 27.5 | 21.9 | 32.9 | 27.5 | 21.8 | 28.5 | 26.7 | 21.4 | 23.3 | 23.3 | | 19.6 | 19.6 | | 70 |
| 75 | 13.7 | 14.5 | 16.1 | 34.8 | 26.8 | 21.6 | 32.4 | 26.8 | 21.5 | 28.2 | 26.1 | 21.1 | 23.2 | 23 | 20.2 | 19.6 | 19.6 | | 75 |
| 80 | | | | 33.9 | 26.1 | 21.3 | 31.7 | 26.1 | 21.2 | 27.9 | 25.5 | 20.8 | 22.9 | 22.5 | 20.2 | 19.6 | 19.6 | | 80 |
| 85 | | | | 32.6 | 25.4 | 21 | 30.6 | 25.5 | 20.9 | 26.9 | 24.9 | 20.6 | 22.2 | 22.1 | 20 | 19.3 | 19.4 | 19.2 | 85 |
| 90 | | | | 31.1 | 24.8 | 20.8 | 29.2 | 24.9 | 20.7 | 25.8 | 24.4 | 20.3 | 21.6 | 21.5 | 19.8 | 18.7 | 18.9 | 19 | 90 |
| 95 | | | | 29.7 | 24.2 | 20.5 | 27.8 | 24.4 | 20.5 | 24.6 | 23.9 | 20.2 | 21 | 20.8 | 19.6 | 18.2 | 18.3 | 18.6 | 95 |
| 100 | | | | 28.3 | 23.6 | 20.3 | 26.5 | 23.9 | 20.2 | 23.6 | 23.4 | 20 | 20.4 | 20.2 | 19.4 | 17.7 | 17.8 | 18.1 | 100 |
| 105 | | | | 27 | 23.2 | 20.1 | 25.2 | 23.4 | 20 | 22.5 | 22.9 | 19.8 | 19.8 | 19.6 | 19.3 | 17.1 | 17.3 | 17.7 | 105 |
| 110 | | | | 25.8 | 22.8 | 19.9 | 24 | 22.9 | 19.9 | 21.6 | 22.1 | 19.7 | 19.2 | 18.9 | 18.9 | 16.6 | 16.9 | 17.2 | 110 |
| 115 | | | | 24.6 | 22.3 | 19.8 | 22.9 | 22.5 | 19.7 | 20.6 | 21.3 | 19.6 | 18.6 | 18.3 | 18.4 | 16.1 | 16.4 | 16.7 | 115 |
| 120 | | | | 23.4 | 22 | 19.6 | 21.8 | 21.9 | 19.6 | 19.7 | 20.3 | 19.4 | 17.9 | 17.8 | 17.8 | 15.7 | 16 | 16.2 | 120 |
| 125 | | | | 22.4 | 21.6 | 19.5 | 20.7 | 21.2 | 19.4 | 18.8 | 19.4 | 19.2 | 17.2 | 17.2 | 17.3 | 15.2 | 15.5 | 15.7 | 125 |
| 130 | | | | 21.5 | 21.2 | 19.4 | 19.5 | 20.1 | 19.2 | 17.9 | 18.5 | 18.9 | 16.5 | 16.7 | 16.7 | 14.5 | 14.9 | 15.2 | 130 |
| 135 | | | | 20.6 | 20.5 | 19.3 | 18.4 | 19.1 | 19.1 | 17.1 | 17.6 | 18.1 | 15.8 | 16.1 | 16.2 | 13.9 | 14.4 | 14.7 | 135 |
| 140 | | | | 19.7 | 19.6 | 19.1 | 17.4 | 18.1 | 18.6 | 16.3 | 16.8 | 17.3 | 15.1 | 15.6 | 15.7 | 13.3 | 13.8 | 14.2 | 140 |
| 145 | | | | 18.8 | 18.8 | 18.9 | 16.6 | 17.1 | 17.7 | 15.5 | 15.9 | 16.5 | 14.4 | 15 | 15.2 | 12.7 | 13.2 | 13.7 | 145 |
| 150 | | | | 18 | 18.1 | 18.2 | 16 | 16.1 | 16.8 | 14.7 | 15.1 | 15.7 | 13.8 | 14.3 | 14.8 | 12.1 | 12.6 | 13.1 | 150 |
| 155 | | | | 17.2 | 17.3 | 17.5 | 15.4 | 15.4 | 15.9 | 13.9 | 14.4 | 14.9 | 13.2 | 13.7 | 14.2 | 11.5 | 12 | 12.5 | 155 |
| 160 | | | | 16.5 | 16.6 | 16.8 | 14.8 | 14.7 | 15 | 13.3 | 13.7 | 14.1 | 12.6 | 13.1 | 13.5 | 11 | 11.4 | 11.9 | 160 |
| 165 | | | | 15.9 | 15.9 | 16.2 | 14.2 | 14.1 | 14.3 | 12.8 | 13 | 13.4 | 12 | 12.5 | 12.8 | 10.4 | 10.9 | 11.4 | 165 |
| 170 | | | | 15.3 | 15.3 | 15.5 | 13.7 | 13.5 | 13.7 | 12.3 | 12.5 | 12.7 | 11.5 | 11.9 | 12.2 | 9.9 | 10.3 | 10.8 | 170 |
| 175 | | | | 14.8 | 14.8 | 14.9 | 13.2 | 12.9 | 13.1 | 11.9 | 12 | 12.1 | 10.9 | 11.3 | 11.6 | 9.4 | 9.8 | 10.2 | 175 |
| 180 | | | | 14.2 | 14.3 | 14.3 | 12.7 | 12.4 | 12.6 | 11.4 | 11.5 | 11.6 | 10.3 | 10.7 | 11 | 8.9 | 9.4 | 9.7 | 180 |
| 185 | | | | 13.7 | 13.8 | | 12.2 | 11.9 | 12.1 | 11 | 11.1 | 11.1 | 9.7 | 10.1 | 10.4 | 8.5 | 8.9 | 9.2 | 185 |
| 190 | | | | 13.2 | 13.3 | | 11.7 | 11.5 | 11.5 | 10.5 | 10.7 | 10.7 | 9.2 | 9.6 | 9.9 | 8.1 | 8.5 | 8.8 | 190 |
| 195 | | | | 10.6 | | | 11.2 | 11 | 11.1 | 10.1 | 10.3 | 10.3 | 8.6 | 9.1 | 9.3 | 7.7 | 8 | 8.3 | 195 |
| 200 | | | | | | | 10.8 | 10.6 | | 9.7 | 9.9 | 9.8 | 8.2 | 8.7 | 8.8 | 7.3 | 7.6 | 7.9 | 200 |
| 205 | | | | | | | 10.3 | 10.2 | | 9.3 | 9.5 | 9.4 | 7.8 | 8.2 | 8.2 | 7 | 7.1 | 7.5 | 205 |
| 210 | | | | | | | | | | 9 | 9.1 | 9 | 7.3 | 7.8 | 7.7 | 6.6 | 6.7 | 7.1 | 210 |
| 215 | | | | | | | | | | 8.6 | 8.7 | 8.6 | 7 | 7.3 | 7.2 | 6.3 | 6.4 | 6.7 | 215 |
| 220 | | | | | | | | | | 8.2 | 8.3 | | 6.6 | 6.9 | 6.7 | 6 | 6 | 6.2 | 220 |
| 225 | | | | | | | | | | | | | 6.2 | 6.5 | 6.3 | 5.6 | 5.6 | 5.8 | 225 |
| 230 | | | | | | | | | | | | | 5.8 | 6.1 | | 5.2 | 5.3 | 5.4 | 230 |
| 235 | | | | | | | | | | | | | 5.5 | 5.7 | | 4.9 | 4.9 | 5 | 235 |
| 240 | | | | | | | | | | | | | 5.1 | 5.3 | | 4.5 | 4.6 | 4.6 | 240 |
| 245 | | | | | | | | | | | | | | | | 4.1 | 4.3 | | 245 |
| 250 | | | | | | | | | | | | | | | | 3.8 | 3.9 | | 250 |
| 255 | | | | | | | | | | | | | | | | 3.4 | 3.5 | | 255 |

TAB 131246 / 131254 / 131262

Lifting capacities Forces de levage

TK



| ft | 51 ft | | | 170 ft | | | 187 ft | | | 204 ft | | | 221 ft | | | 236 ft | | | ft |
|-----|-------|------|------|--------|------|------|--------|------|------|--------|------|------|--------|------|------|--------|------|-----|-----|
| | 72 ft | | | 72 ft | | | 72 ft | | | 72 ft | | | 72 ft | | | 72 ft | | | |
| | 0° | 20° | 40° | 0° | 20° | 40° | 0° | 20° | 40° | 0° | 20° | 40° | 0° | 20° | 40° | 0° | 20° | 40° | |
| 13 | 17 | | | | | | | | | | | | | | | | | | 13 |
| 14 | 17 | | | | | | | | | | | | | | | | | | 14 |
| 15 | 17 | | | | | | | | | | | | | | | | | | 15 |
| 16 | 17 | | | | | | | | | | | | | | | | | | 16 |
| 17 | 17 | | | | | | | | | | | | | | | | | | 17 |
| 18 | 17 | | | | | | | | | | | | | | | | | | 18 |
| 20 | 17 | | | | | | | | | | | | | | | | | | 20 |
| 22 | 17 | | | | | | | | | | | | | | | | | | 22 |
| 24 | 17 | | | | | | | | | | | | | | | | | | 24 |
| 26 | 16.9 | | | | | | | | | | | | | | | | | | 26 |
| 28 | 16.8 | | | | | | | | | | | | | | | | | | 28 |
| 30 | 16.6 | | | | | | | | | | | | | | | | | | 30 |
| 32 | 16.4 | | | | | | | | | | | | | | | | | | 32 |
| 34 | 16.2 | | | | | | | | | | | | | | | | | | 34 |
| 36 | 16 | 14.6 | | 17 | | | | | | | | | | | | | | | 36 |
| 38 | 15.9 | 14.6 | | 17 | | | 16 | | | | | | | | | | | | 38 |
| 40 | 15.7 | 14.5 | | 17 | | | 16 | | | | | | | | | | | | 40 |
| 45 | 15.1 | 14 | | 17 | | | 16 | | | 14.3 | | | | | | | | | 45 |
| 50 | 14.6 | 13.4 | | 17 | | | 16 | | | 14.3 | | | 13.1 | | | | | | 50 |
| 55 | 14 | 12.9 | 11.4 | 17 | | | 16 | | | 14.3 | | | 13.1 | | | 11.6 | | | 55 |
| 60 | 13.5 | 12.4 | 11.3 | 16.9 | | | 16 | | | 14.3 | | | 13.1 | | | 11.6 | | | 60 |
| 65 | 13 | 12 | 10.9 | 16.8 | 14.6 | | 15.9 | | | 14.3 | | | 13 | | | 11.6 | | | 65 |
| 70 | 12.5 | 11.6 | 10.5 | 16.5 | 14.4 | | 15.7 | 14 | | 14.3 | | | 12.9 | | | 11.6 | | | 70 |
| 75 | 12.2 | 11.2 | 10.2 | 16.3 | 14.1 | | 15.5 | 13.8 | | 14.2 | 12.9 | | 12.9 | | | 11.6 | | | 75 |
| 80 | 11.9 | 10.9 | 9.9 | 16 | 13.8 | | 15.3 | 13.5 | | 14.1 | 12.8 | | 12.8 | | | 11.6 | | | 80 |
| 85 | 11.6 | 10.7 | 9.7 | 15.8 | 13.6 | 11.4 | 15.1 | 13.3 | 11.2 | 14 | 12.7 | | 12.6 | 11.9 | | 11.6 | | | 85 |
| 90 | 11.2 | 10.4 | 9.5 | 15.6 | 13.3 | 11.3 | 14.9 | 13 | 11.1 | 13.9 | 12.5 | 10.7 | 12.6 | 11.8 | | 11.5 | 10.9 | | 90 |
| 95 | 10.8 | 10.1 | 9.4 | 15.3 | 13 | 11.1 | 14.7 | 12.8 | 11 | 13.7 | 12.3 | 10.7 | 12.5 | 11.6 | 10.2 | 11.4 | 10.9 | | 95 |
| 100 | 10.3 | 9.9 | 9.3 | 15 | 12.8 | 10.9 | 14.5 | 12.6 | 10.9 | 13.6 | 12.1 | 10.6 | 12.4 | 11.4 | 10.2 | 11.3 | 10.8 | 9.7 | 100 |
| 105 | 9.6 | 9.7 | | 14.7 | 12.5 | 10.7 | 14.3 | 12.4 | 10.7 | 13.4 | 11.9 | 10.5 | 12.3 | 11.3 | 10.1 | 11.2 | 10.7 | 9.7 | 105 |
| 110 | 9 | 9.4 | | 14.4 | 12.3 | 10.5 | 14.1 | 12.1 | 10.6 | 13.3 | 11.7 | 10.3 | 12.2 | 11.1 | 10 | 11.2 | 10.6 | 9.7 | 110 |
| 115 | | | | 14.2 | 12.1 | 10.4 | 13.8 | 12 | 10.4 | 13.1 | 11.6 | 10.2 | 12.1 | 11 | 9.9 | 11.1 | 10.5 | 9.6 | 115 |
| 120 | | | | 13.9 | 11.9 | 10.2 | 13.6 | 11.8 | 10.2 | 12.9 | 11.4 | 10.2 | 12 | 10.9 | 9.8 | 11.1 | 10.4 | 9.4 | 120 |
| 125 | | | | 13.6 | 11.7 | 10 | 13.4 | 11.6 | 10.1 | 12.8 | 11.2 | 10 | 11.9 | 10.7 | 9.7 | 11 | 10.3 | 9.3 | 125 |
| 130 | | | | 13.3 | 11.5 | 9.9 | 13.2 | 11.4 | 10 | 12.6 | 11.1 | 9.9 | 11.8 | 10.6 | 9.5 | 10.9 | 10.2 | 9.2 | 130 |
| 135 | | | | 13.1 | 11.4 | 9.8 | 12.9 | 11.3 | 9.9 | 12.4 | 11 | 9.8 | 11.7 | 10.5 | 9.4 | 10.9 | 10.1 | 9.1 | 135 |
| 140 | | | | 12.8 | 11.2 | 9.7 | 12.7 | 11.1 | 9.8 | 12.3 | 10.8 | 9.6 | 11.6 | 10.4 | 9.4 | 10.8 | 10 | 9 | 140 |
| 145 | | | | 12.6 | 11.1 | 9.7 | 12.5 | 11 | 9.7 | 12.1 | 10.7 | 9.5 | 11.4 | 10.3 | 9.3 | 10.7 | 10 | 9 | 145 |
| 150 | | | | 12.4 | 10.9 | 9.6 | 12.3 | 10.9 | 9.6 | 11.9 | 10.7 | 9.5 | 11.3 | 10.2 | 9.2 | 10.4 | 9.9 | 8.9 | 150 |
| 155 | | | | 12.2 | 10.8 | 9.5 | 12.2 | 10.8 | 9.6 | 11.8 | 10.6 | 9.4 | 11.2 | 10.2 | 9.1 | 10 | 9.8 | 8.8 | 155 |
| 160 | | | | 12.1 | 10.7 | 9.5 | 12 | 10.7 | 9.5 | 11.6 | 10.5 | 9.4 | 11 | 10.1 | 9 | 9.6 | 9.7 | 8.8 | 160 |
| 165 | | | | 11.9 | 10.6 | 9.4 | 11.8 | 10.7 | 9.5 | 11.4 | 10.4 | 9.3 | 10.7 | 10 | 9 | 9.1 | 9.6 | 8.7 | 165 |
| 170 | | | | 11.8 | 10.5 | 9.3 | 11.6 | 10.6 | 9.4 | 11.1 | 10.4 | 9.2 | 10.2 | 9.9 | 9 | 8.8 | 9.5 | 8.7 | 170 |
| 175 | | | | 11.6 | 10.3 | 9.3 | 11.4 | 10.5 | 9.4 | 10.6 | 10.3 | 9.2 | 9.8 | 9.8 | 9 | 8.4 | 9.2 | 8.6 | 175 |
| 180 | | | | 11.5 | 10.2 | 9.3 | 11.1 | 10.3 | 9.4 | 10.1 | 10.1 | 9.2 | 9.4 | 9.7 | 9 | 8 | 8.8 | 8.6 | 180 |
| 185 | | | | 11.3 | 10.1 | 9.3 | 10.6 | 10.2 | 9.3 | 9.7 | 10 | 9.2 | 9 | 9.5 | 9 | 7.6 | 8.4 | 8.6 | 185 |
| 190 | | | | 11.1 | 10 | 9.3 | 10.2 | 10 | 9.3 | 9.2 | 9.8 | 9.2 | 8.6 | 9.3 | 9 | 7.3 | 8 | 8.6 | 190 |
| 195 | | | | 10.8 | 9.8 | 9.3 | 9.8 | 9.9 | 9.3 | 8.8 | 9.4 | 9.2 | 8.2 | 8.9 | 9 | 6.9 | 7.6 | 8.3 | 195 |
| 200 | | | | 10.6 | 9.7 | 9.3 | 9.5 | 9.6 | 9.3 | 8.4 | 8.9 | 9 | 7.8 | 8.5 | 8.8 | 6.6 | 7.2 | 7.9 | 200 |
| 205 | | | | 10.3 | 9.7 | 9.3 | 9.1 | 9.3 | 9.2 | 8.1 | 8.5 | 8.7 | 7.4 | 8.1 | 8.5 | 6.3 | 6.9 | 7.5 | 205 |
| 210 | | | | 10 | 9.7 | 9.3 | 8.8 | 8.9 | 9.1 | 7.7 | 8.1 | 8.4 | 7 | 7.7 | 8.1 | 6 | 6.5 | 7.1 | 210 |
| 215 | | | | 9.7 | 9.6 | 9.3 | 8.4 | 8.6 | 8.7 | 7.5 | 7.8 | 8.1 | 6.7 | 7.2 | 7.6 | 5.7 | 6.2 | 6.7 | 215 |
| 220 | | | | 9.3 | 9.4 | | 8.1 | 8.2 | 8.3 | 7.2 | 7.4 | 7.7 | 6.3 | 6.8 | 7.2 | 5.4 | 5.9 | 6.4 | 220 |
| 225 | | | | | | | 7.8 | 7.9 | 7.9 | 6.9 | 7.1 | 7.4 | 6 | 6.4 | 6.7 | 5.1 | 5.6 | 6 | 225 |
| 230 | | | | | | | 7.5 | 7.5 | | 6.7 | 6.8 | 7 | 5.7 | 6.1 | 6.3 | 4.9 | 5.3 | 5.6 | 230 |
| 235 | | | | | | | 7.2 | 7.2 | | 6.4 | 6.6 | 6.7 | 5.4 | 5.7 | 5.9 | 4.5 | 5 | 5.3 | 235 |
| 240 | | | | | | | 6.9 | | | 6.2 | 6.3 | 6.3 | 5.1 | 5.4 | 5.5 | 4.2 | 4.7 | 5 | 240 |
| 245 | | | | | | | | | | 6 | 6.1 | | 4.9 | 5.1 | 5.2 | 3.9 | 4.4 | 4.6 | 245 |
| 250 | | | | | | | | | | 5.7 | 5.8 | | 4.6 | 4.8 | 4.8 | 3.6 | 4.1 | 4.3 | 250 |
| 255 | | | | | | | | | | 5.5 | 5.6 | | 4.3 | 4.4 | 4.4 | 3.3 | 3.7 | 3.9 | 255 |
| 260 | | | | | | | | | | | | | 4 | 4.2 | 4.1 | 3 | 3.4 | 3.5 | 260 |
| 265 | | | | | | | | | | | | | 3.7 | 3.8 | | 2.7 | 3 | 3.1 | 265 |
| 270 | | | | | | | | | | | | | 3.4 | 3.5 | | 2.4 | 2.7 | 2.7 | 270 |
| 275 | | | | | | | | | | | | | 3.1 | 3.2 | | 2.2 | 2.4 | 2.3 | 275 |

TAB 131246 / 131254 / 131262

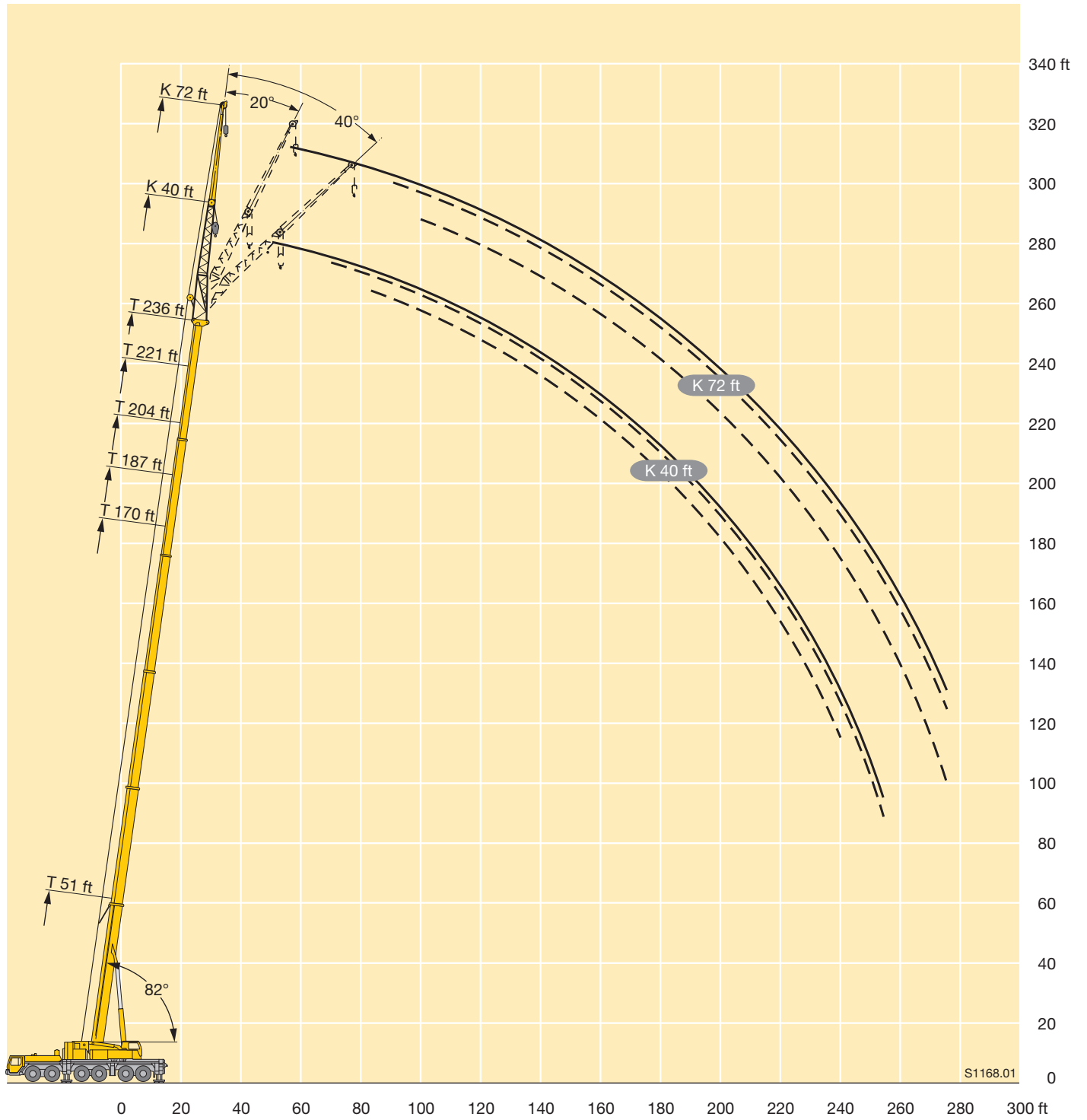

S1168.01

Lifting capacities Forces de levage

TK



| ft | 51 ft | | | 170 ft | | | 187 ft | | | 204 ft | | | 221 ft | | | 236 ft | | | ft |
|-----|-------|-----|-----|--------|-----|-----|--------|-----|-----|--------|-----|-----|--------|-----|-----|--------|-----|-----|-----|
| | 95 ft | | | 95 ft | | | 95 ft | | | 95 ft | | | 95 ft | | | 95 ft | | | |
| | 0° | 20° | 40° | 0° | 20° | 40° | 0° | 20° | 40° | 0° | 20° | 40° | 0° | 20° | 40° | 0° | 20° | 40° | |
| 16 | 12.9 | | | | | | | | | | | | | | | | | | 16 |
| 17 | 12.9 | | | | | | | | | | | | | | | | | | 17 |
| 18 | 12.9 | | | | | | | | | | | | | | | | | | 18 |
| 20 | 12.9 | | | | | | | | | | | | | | | | | | 20 |
| 22 | 12.9 | | | | | | | | | | | | | | | | | | 22 |
| 24 | 12.9 | | | | | | | | | | | | | | | | | | 24 |
| 26 | 12.9 | | | | | | | | | | | | | | | | | | 26 |
| 28 | 12.8 | | | | | | | | | | | | | | | | | | 28 |
| 30 | 12.8 | | | | | | | | | | | | | | | | | | 30 |
| 32 | 12.8 | | | | | | | | | | | | | | | | | | 32 |
| 34 | 12.7 | | | | | | | | | | | | | | | | | | 34 |
| 36 | 12.6 | | | | | | | | | | | | | | | | | | 36 |
| 38 | 12.4 | | | 12.9 | | | | | | | | | | | | | | | 38 |
| 40 | 12.1 | | | 12.9 | | | | | | | | | | | | | | | 40 |
| 45 | 11.5 | | | 12.9 | | | 11.6 | | | | | | | | | | | | 45 |
| 50 | 11 | 9.9 | | 12.9 | | | 11.6 | | | 10.2 | | | | | | | | | 50 |
| 55 | 10.5 | 9.7 | | 12.8 | | | 11.6 | | | 10.2 | | | 9 | | | | | | 55 |
| 60 | 10 | 9.2 | | 12.8 | | | 11.6 | | | 10.2 | | | 9 | | | | | | 60 |
| 65 | 9.6 | 8.7 | | 12.8 | | | 11.6 | | | 10.2 | | | 9 | | | | | | 65 |
| 70 | 9.2 | 8.3 | 7 | 12.7 | | | 11.6 | | | 10.2 | | | 9 | | | 7.8 | | | 70 |
| 75 | 8.8 | 7.9 | 6.9 | 12.5 | 10 | | 11.6 | | | 10.2 | | | 9 | | | 7.8 | | | 75 |
| 80 | 8.5 | 7.6 | 6.7 | 12.2 | 9.9 | | 11.6 | | | 10.2 | | | 9 | | | 7.8 | | | 80 |
| 85 | 8.1 | 7.3 | 6.5 | 11.8 | 9.6 | | 11.5 | 9.2 | | 10.2 | 8.5 | | 9 | | | 7.8 | | | 85 |
| 90 | 7.8 | 7 | 6.2 | 11.5 | 9.3 | | 11.2 | 9.1 | | 10.2 | 8.5 | | 9 | 7.8 | | 7.8 | | | 90 |
| 95 | 7.6 | 6.8 | 6 | 11.2 | 9.1 | 7 | 10.9 | 8.9 | | 10.1 | 8.4 | | 9 | 7.8 | | 7.8 | 7 | | 95 |
| 100 | 7.3 | 6.6 | 5.9 | 10.9 | 8.8 | 7 | 10.6 | 8.7 | 6.8 | 9.9 | 8.2 | | 9 | 7.7 | | 7.8 | 7 | | 100 |
| 105 | 7 | 6.3 | 5.8 | 10.6 | 8.6 | 6.9 | 10.4 | 8.4 | 6.8 | 9.7 | 8.1 | | 8.9 | 7.5 | | 7.8 | 7 | | 105 |
| 110 | 6.8 | 6.1 | 5.7 | 10.4 | 8.4 | 6.8 | 10.2 | 8.3 | 6.7 | 9.5 | 7.9 | 6.3 | 8.7 | 7.4 | | 7.8 | 7 | | 110 |
| 115 | 6.6 | 6 | 5.6 | 10.1 | 8.2 | 6.6 | 9.9 | 8.1 | 6.6 | 9.3 | 7.7 | 6.3 | 8.6 | 7.3 | 5.8 | 7.8 | 6.9 | | 115 |
| 120 | 6.4 | 5.8 | 5.6 | 9.9 | 8 | 6.5 | 9.7 | 7.9 | 6.5 | 9.1 | 7.5 | 6.3 | 8.4 | 7.1 | 5.8 | 7.7 | 6.8 | 5.6 | 120 |
| 125 | 6.2 | 5.7 | 5.5 | 9.6 | 7.8 | 6.4 | 9.4 | 7.7 | 6.4 | 8.9 | 7.4 | 6.3 | 8.2 | 7 | 5.8 | 7.7 | 6.6 | 5.6 | 125 |
| 130 | 6 | 5.7 | 5 | 9.4 | 7.6 | 6.3 | 9.2 | 7.5 | 6.3 | 8.8 | 7.3 | 6.2 | 8.1 | 6.9 | 5.8 | 7.6 | 6.5 | 5.6 | 130 |
| 135 | | | | 9.2 | 7.5 | 6.2 | 9 | 7.4 | 6.2 | 8.6 | 7.1 | 6.1 | 7.9 | 6.8 | 5.8 | 7.4 | 6.4 | 5.6 | 135 |
| 140 | | | | 9 | 7.3 | 6.1 | 8.8 | 7.2 | 6.1 | 8.4 | 7 | 6 | 7.8 | 6.7 | 5.8 | 7.3 | 6.3 | 5.6 | 140 |
| 145 | | | | 8.8 | 7.1 | 6 | 8.6 | 7.1 | 6 | 8.2 | 6.8 | 6 | 7.7 | 6.5 | 5.8 | 7.2 | 6.3 | 5.6 | 145 |
| 150 | | | | 8.6 | 7 | 5.9 | 8.5 | 6.9 | 6 | 8.1 | 6.7 | 5.9 | 7.5 | 6.4 | 5.8 | 7.1 | 6.2 | 5.6 | 150 |
| 155 | | | | 8.4 | 6.9 | 5.9 | 8.3 | 6.8 | 5.9 | 7.9 | 6.6 | 5.9 | 7.4 | 6.3 | 5.7 | 7 | 6.1 | 5.6 | 155 |
| 160 | | | | 8.2 | 6.8 | 5.8 | 8.1 | 6.7 | 5.8 | 7.7 | 6.6 | 5.8 | 7.3 | 6.3 | 5.7 | 6.9 | 6 | 5.5 | 160 |
| 165 | | | | 8 | 6.7 | 5.8 | 7.9 | 6.6 | 5.7 | 7.6 | 6.5 | 5.7 | 7.2 | 6.2 | 5.6 | 6.8 | 6 | 5.5 | 165 |
| 170 | | | | 7.9 | 6.6 | 5.7 | 7.8 | 6.6 | 5.7 | 7.4 | 6.4 | 5.7 | 7.1 | 6.1 | 5.6 | 6.7 | 5.9 | 5.4 | 170 |
| 175 | | | | 7.7 | 6.5 | 5.7 | 7.6 | 6.5 | 5.6 | 7.3 | 6.4 | 5.6 | 7 | 6.1 | 5.5 | 6.6 | 5.8 | 5.4 | 175 |
| 180 | | | | 7.6 | 6.4 | 5.6 | 7.5 | 6.4 | 5.6 | 7.2 | 6.3 | 5.6 | 6.9 | 6 | 5.5 | 6.5 | 5.8 | 5.4 | 180 |
| 185 | | | | 7.4 | 6.2 | 5.6 | 7.3 | 6.3 | 5.5 | 7.1 | 6.2 | 5.5 | 6.8 | 6 | 5.4 | 6.4 | 5.8 | 5.4 | 185 |
| 190 | | | | 7.3 | 6.1 | 5.6 | 7.2 | 6.3 | 5.5 | 7 | 6.1 | 5.5 | 6.7 | 6 | 5.4 | 6.3 | 5.7 | 5.3 | 190 |
| 195 | | | | 7.1 | 6.1 | 5.6 | 7.1 | 6.2 | 5.4 | 6.9 | 6.1 | 5.4 | 6.6 | 5.9 | 5.4 | 6.1 | 5.7 | 5.3 | 195 |
| 200 | | | | 7 | 6 | 5.6 | 7 | 6.1 | 5.4 | 6.8 | 6.1 | 5.4 | 6.6 | 5.9 | 5.4 | 5.8 | 5.6 | 5.3 | 200 |
| 205 | | | | 6.8 | 5.9 | 5.6 | 6.9 | 6.1 | 5.4 | 6.8 | 6 | 5.4 | 6.5 | 5.9 | 5.4 | 5.5 | 5.6 | 5.3 | 205 |
| 210 | | | | 6.7 | 5.8 | 5.6 | 6.8 | 6 | 5.4 | 6.7 | 6 | 5.4 | 6.4 | 5.8 | 5.4 | 5.3 | 5.5 | 5.3 | 210 |
| 215 | | | | 6.6 | 5.8 | 5.6 | 6.7 | 5.9 | 5.4 | 6.5 | 5.9 | 5.4 | 6.1 | 5.8 | 5.4 | 5 | 5.5 | 5.3 | 215 |
| 220 | | | | 6.5 | 5.8 | 5.6 | 6.6 | 5.9 | 5.4 | 6.3 | 5.9 | 5.4 | 5.8 | 5.8 | 5.4 | 4.7 | 5.4 | 5.3 | 220 |
| 225 | | | | 6.4 | 5.7 | 5.6 | 6.5 | 5.8 | 5.4 | 6.1 | 5.8 | 5.4 | 5.6 | 5.8 | 5.4 | 4.4 | 5.3 | 5.3 | 225 |
| 230 | | | | 6.3 | 5.7 | 5.6 | 6.4 | 5.8 | 5.4 | 5.9 | 5.8 | 5.4 | 5.3 | 5.7 | 5.4 | 4.2 | 5 | 5.3 | 230 |
| 235 | | | | 6.2 | 5.7 | 5.6 | 6.2 | 5.7 | 5.4 | 5.7 | 5.7 | 5.4 | 5 | 5.6 | 5.4 | 3.9 | 4.7 | 5.1 | 235 |
| 240 | | | | 6.1 | 5.7 | | 6 | 5.6 | 5.4 | 5.5 | 5.5 | 5.4 | 4.7 | 5.3 | 5.4 | 3.6 | 4.4 | 4.9 | 240 |
| 245 | | | | 6 | | | 5.8 | 5.6 | 5.4 | 5.3 | 5.3 | 5.4 | 4.4 | 5 | 5.3 | 3.4 | 4.1 | 4.7 | 245 |
| 250 | | | | | | | 5.6 | 5.5 | | 5.1 | 5.1 | 5.4 | 4.1 | 4.7 | 5 | 3.1 | 3.8 | 4.3 | 250 |
| 255 | | | | | | | 5.4 | 5.4 | | 4.9 | 4.9 | 5.1 | 3.7 | 4.4 | 4.6 | 2.9 | 3.5 | 4 | 255 |
| 260 | | | | | | | 5.2 | 5.3 | | 4.7 | 4.8 | 4.8 | 3.5 | 4.1 | 4.3 | 2.6 | 3.2 | 3.6 | 260 |
| 265 | | | | | | | | | | 4.5 | 4.6 | 4.4 | 3.2 | 3.7 | 3.9 | | 2.9 | 3.2 | 265 |
| 270 | | | | | | | | | | 4.3 | 4.4 | | 2.9 | 3.4 | 3.5 | | 2.6 | 2.8 | 270 |
| 275 | | | | | | | | | | 4.2 | 4.2 | | 2.7 | 3.1 | 3.1 | | 2.3 | 2.5 | 275 |
| 280 | | | | | | | | | | 4 | | | 2.4 | 2.8 | 2.7 | | | | 280 |
| 285 | | | | | | | | | | | | | | 2.4 | | | | | 285 |

TAB 131246 / 131254 / 131262

Lifting heights Hauteurs de levage

TK

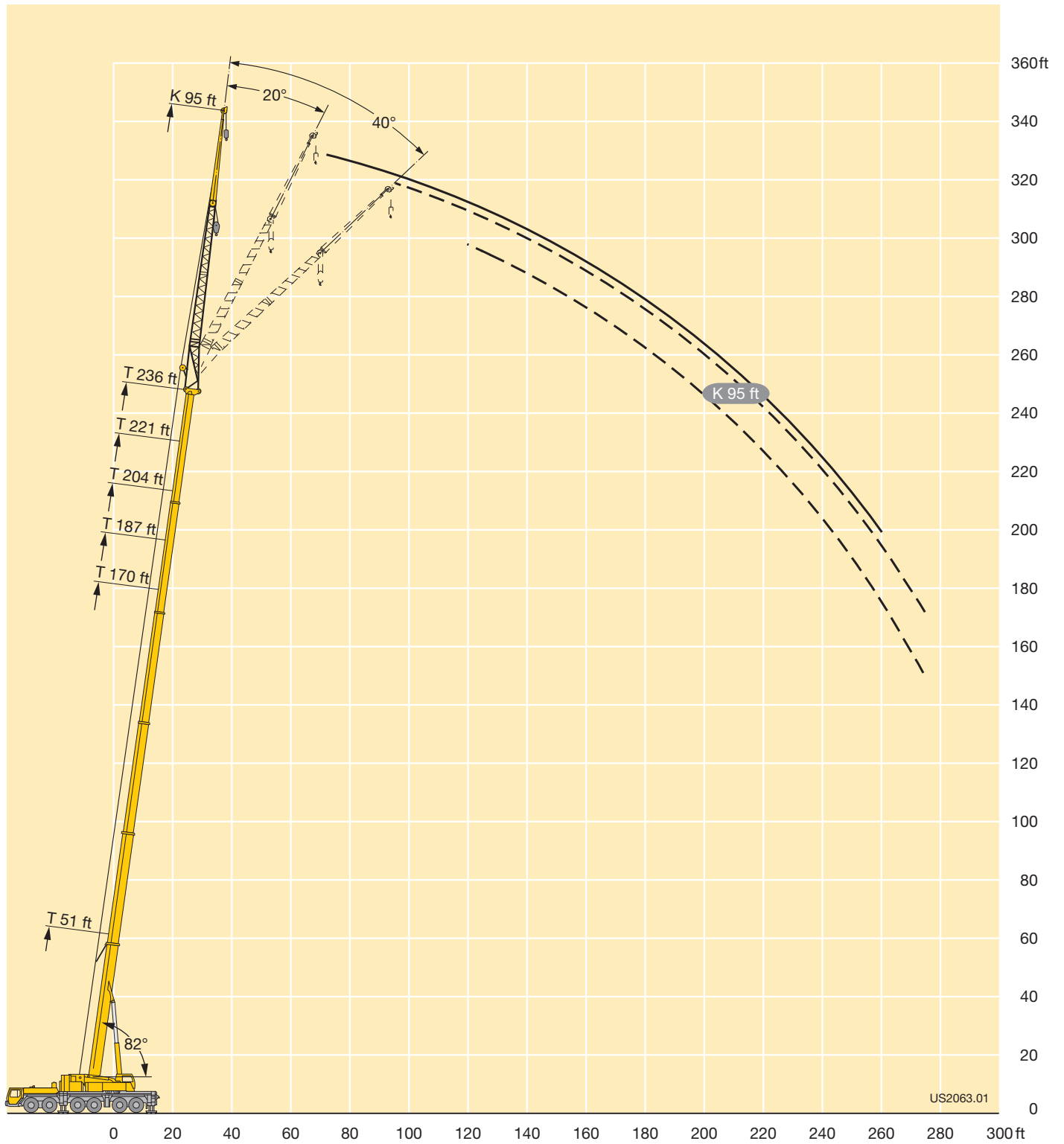

Lifting capacities Forces de levage

TK



| ft | 51 ft | | | 170 ft | | | 187 ft | | | 204 ft | | | 221 ft | | | 236 ft | | | ft |
|-----|--------|-----|-----|--------|-----|-----|--------|-----|-----|--------|-----|-----|--------|-----|-----|--------|-----|-----|-----|
| | 118 ft | | | 118 ft | | | 118 ft | | | 118 ft | | | 118 ft | | | 118 ft | | | |
| | 0° | 20° | 40° | 0° | 20° | 40° | 0° | 20° | 40° | 0° | 20° | 40° | 0° | 20° | 40° | 0° | 20° | 40° | |
| 18 | 8.7 | | | | | | | | | | | | | | | | | | 18 |
| 20 | 8.7 | | | | | | | | | | | | | | | | | | 20 |
| 22 | 8.7 | | | | | | | | | | | | | | | | | | 22 |
| 24 | 8.7 | | | | | | | | | | | | | | | | | | 24 |
| 26 | 8.7 | | | | | | | | | | | | | | | | | | 26 |
| 28 | 8.7 | | | | | | | | | | | | | | | | | | 28 |
| 30 | 8.7 | | | | | | | | | | | | | | | | | | 30 |
| 32 | 8.7 | | | | | | | | | | | | | | | | | | 32 |
| 34 | 8.7 | | | | | | | | | | | | | | | | | | 34 |
| 36 | 8.7 | | | | | | | | | | | | | | | | | | 36 |
| 38 | 8.7 | | | | | | | | | | | | | | | | | | 38 |
| 40 | 8.7 | | | | | | | | | | | | | | | | | | 40 |
| 45 | 8.4 | | | | | | | | | | | | | | | | | | 45 |
| 50 | 8 | | | 8.5 | | | | | | | | | | | | | | | 50 |
| 55 | 7.6 | 6.1 | | 8.5 | | | 7.8 | | | | | | | | | | | | 55 |
| 60 | 7.2 | 6.1 | | 8.5 | | | 7.8 | | | | | | | | | | | | 60 |
| 65 | 6.9 | 6.1 | | 8.5 | | | 7.8 | | | 6.8 | | | | | | | | | 65 |
| 70 | 6.5 | 5.9 | | 8.5 | | | 7.8 | | | 6.8 | | | 5.8 | | | | | | 70 |
| 75 | 6.2 | 5.7 | | 8.5 | | | 7.8 | | | 6.8 | | | 5.8 | | | 4.9 | | | 75 |
| 80 | 6 | 5.4 | | 8.5 | | | 7.8 | | | 6.8 | | | 5.8 | | | 4.9 | | | 80 |
| 85 | 5.7 | 5.2 | | 8.3 | | | 7.8 | | | 6.8 | | | 5.8 | | | 4.9 | | | 85 |
| 90 | 5.4 | 5 | 4.4 | 8.1 | 6.1 | | 7.7 | 5.8 | | 6.8 | | | 5.8 | | | 4.9 | | | 90 |
| 95 | 5.2 | 4.7 | 4.3 | 7.8 | 6 | | 7.6 | 5.8 | | 6.8 | | | 5.8 | | | 4.9 | | | 95 |
| 100 | 5 | 4.6 | 4.2 | 7.6 | 6 | | 7.3 | 5.7 | | 6.8 | 5.1 | | 5.8 | 4.6 | | 4.9 | | | 100 |
| 105 | 4.9 | 4.4 | 4 | 7.4 | 5.8 | | 7.1 | 5.6 | | 6.6 | 5.1 | | 5.8 | 4.6 | | 4.9 | | | 105 |
| 110 | 4.7 | 4.3 | 3.9 | 7.2 | 5.7 | | 6.9 | 5.5 | | 6.5 | 5.1 | | 5.8 | 4.6 | | 4.9 | 4.1 | | 110 |
| 115 | 4.6 | 4.2 | 3.8 | 7 | 5.5 | 4.1 | 6.7 | 5.4 | | 6.3 | 5.1 | | 5.7 | 4.6 | | 4.9 | 4.1 | | 115 |
| 120 | 4.5 | 4.1 | 3.7 | 6.8 | 5.3 | 4.1 | 6.5 | 5.3 | 3.9 | 6.2 | 5.1 | | 5.6 | 4.6 | | 4.9 | 4.1 | | 120 |
| 125 | 4.3 | 3.9 | 3.6 | 6.6 | 5.2 | 4.1 | 6.4 | 5.1 | 3.9 | 6 | 4.9 | | 5.6 | 4.6 | | 4.9 | 4.1 | | 125 |
| 130 | 4.2 | 3.9 | 3.5 | 6.4 | 5.1 | 4.1 | 6.2 | 5 | 3.9 | 5.9 | 4.8 | 3.6 | 5.4 | 4.6 | | 4.9 | 4.1 | | 130 |
| 135 | 4.1 | 3.8 | 3.4 | 6.2 | 5 | 4 | 6.1 | 4.9 | 3.9 | 5.7 | 4.7 | 3.6 | 5.3 | 4.5 | 3.5 | 4.9 | 4.1 | | 135 |
| 140 | 4 | 3.7 | 3.4 | 6.1 | 4.8 | 3.9 | 5.9 | 4.8 | 3.9 | 5.6 | 4.6 | 3.6 | 5.2 | 4.4 | 3.5 | 4.8 | 4.1 | 3.2 | 140 |
| 145 | 3.9 | 3.6 | 3.4 | 5.9 | 4.7 | 3.9 | 5.8 | 4.7 | 3.9 | 5.5 | 4.6 | 3.6 | 5.1 | 4.3 | 3.5 | 4.8 | 4.1 | 3.2 | 145 |
| 150 | 3.8 | 3.5 | 3.4 | 5.8 | 4.6 | 3.9 | 5.7 | 4.6 | 3.7 | 5.4 | 4.5 | 3.6 | 5 | 4.2 | 3.5 | 4.7 | 4 | 3.2 | 150 |
| 155 | 3.7 | 3.4 | | 5.6 | 4.5 | 3.8 | 5.6 | 4.5 | 3.6 | 5.3 | 4.4 | 3.6 | 4.9 | 4.2 | 3.5 | 4.6 | 4 | 3.2 | 155 |
| 160 | | | | 5.5 | 4.4 | 3.7 | 5.4 | 4.4 | 3.6 | 5.2 | 4.3 | 3.6 | 4.9 | 4.1 | 3.5 | 4.6 | 3.9 | 3.2 | 160 |
| 165 | | | | 5.3 | 4.4 | 3.7 | 5.3 | 4.3 | 3.6 | 5.1 | 4.2 | 3.6 | 4.8 | 4 | 3.5 | 4.5 | 3.9 | 3.2 | 165 |
| 170 | | | | 5.2 | 4.4 | 3.7 | 5.2 | 4.3 | 3.6 | 5 | 4.1 | 3.5 | 4.7 | 4 | 3.5 | 4.4 | 3.8 | 3.2 | 170 |
| 175 | | | | 5.1 | 4.3 | 3.6 | 5.1 | 4.2 | 3.6 | 4.9 | 4.1 | 3.5 | 4.6 | 3.9 | 3.5 | 4.4 | 3.8 | 3.2 | 175 |
| 180 | | | | 5 | 4.2 | 3.6 | 5 | 4.2 | 3.6 | 4.8 | 4 | 3.5 | 4.6 | 3.9 | 3.4 | 4.3 | 3.7 | 3.2 | 180 |
| 185 | | | | 4.9 | 4.2 | 3.6 | 4.9 | 4.1 | 3.6 | 4.7 | 4 | 3.5 | 4.5 | 3.8 | 3.4 | 4.3 | 3.7 | 3.2 | 185 |
| 190 | | | | 4.8 | 4.1 | 3.5 | 4.8 | 4.1 | 3.5 | 4.6 | 4 | 3.5 | 4.4 | 3.8 | 3.4 | 4.2 | 3.6 | 3.2 | 190 |
| 195 | | | | 4.7 | 4 | 3.5 | 4.7 | 4 | 3.5 | 4.6 | 3.9 | 3.5 | 4.4 | 3.7 | 3.4 | 4.1 | 3.6 | 3.2 | 195 |
| 200 | | | | 4.6 | 4 | 3.5 | 4.6 | 4 | 3.5 | 4.5 | 3.9 | 3.5 | 4.3 | 3.7 | 3.4 | 4.1 | 3.6 | 3.2 | 200 |
| 205 | | | | 4.6 | 3.9 | 3.4 | 4.6 | 3.9 | 3.4 | 4.4 | 3.9 | 3.4 | 4.2 | 3.7 | 3.4 | 4.1 | 3.5 | 3.2 | 205 |
| 210 | | | | 4.5 | 3.9 | 3.4 | 4.5 | 3.9 | 3.4 | 4.4 | 3.8 | 3.4 | 4.2 | 3.7 | 3.4 | 4 | 3.5 | 3.2 | 210 |
| 215 | | | | 4.4 | 3.8 | 3.4 | 4.4 | 3.8 | 3.4 | 4.3 | 3.8 | 3.4 | 4.1 | 3.7 | 3.4 | 3.9 | 3.5 | 3.2 | 215 |
| 220 | | | | 4.3 | 3.8 | 3.4 | 4.4 | 3.8 | 3.4 | 4.3 | 3.7 | 3.4 | 4.1 | 3.6 | 3.4 | 3.8 | 3.4 | 3.2 | 220 |
| 225 | | | | 4.2 | 3.7 | 3.4 | 4.3 | 3.8 | 3.4 | 4.2 | 3.7 | 3.4 | 4.1 | 3.6 | 3.4 | 3.7 | 3.4 | 3.2 | 225 |
| 230 | | | | 4.2 | 3.7 | 3.4 | 4.3 | 3.7 | 3.4 | 4.1 | 3.7 | 3.4 | 4 | 3.6 | 3.4 | 3.4 | 3.4 | 3.2 | 230 |
| 235 | | | | 4.1 | 3.6 | 3.4 | 4.2 | 3.7 | 3.4 | 4.1 | 3.6 | 3.4 | 4 | 3.6 | 3.4 | 3.2 | 3.3 | 3.2 | 235 |
| 240 | | | | 4.1 | 3.6 | 3.4 | 4.1 | 3.6 | 3.4 | 4 | 3.6 | 3.4 | 3.9 | 3.5 | 3.4 | 2.9 | 3.3 | 3.2 | 240 |
| 245 | | | | 4 | 3.5 | 3.4 | 4.1 | 3.6 | 3.4 | 4 | 3.5 | 3.4 | 3.8 | 3.5 | 3.3 | 2.7 | 3.2 | 3.2 | 245 |
| 250 | | | | 3.9 | 3.5 | 3.4 | 4 | 3.6 | 3.4 | 3.9 | 3.5 | 3.4 | 3.6 | 3.4 | 3.3 | | 3.1 | 3.2 | 250 |
| 255 | | | | 3.9 | 3.5 | 3.4 | 4 | 3.5 | 3.4 | 3.9 | 3.5 | 3.4 | 3.3 | 3.4 | 3.3 | | 3 | 3.2 | 255 |
| 260 | | | | 3.8 | 3.4 | | 3.9 | 3.5 | 3.4 | 3.8 | 3.4 | 3.4 | 3 | 3.4 | 3.3 | | 2.8 | 3.2 | 260 |
| 265 | | | | 3.7 | 3.4 | | 3.8 | 3.4 | 3.4 | 3.8 | 3.4 | 3.4 | 2.7 | 3.3 | 3.3 | | 2.6 | 3.1 | 265 |
| 270 | | | | | | | 3.7 | 3.4 | | 3.6 | 3.3 | 3.4 | 2.5 | 3.2 | 3.2 | | | 2.9 | 270 |
| 275 | | | | | | | 3.7 | 3.4 | | 3.4 | 3.3 | 3.2 | 2.2 | 2.9 | 3.2 | | | 2.6 | 275 |
| 280 | | | | | | | 3.7 | 3.4 | | 3.3 | 3.3 | 3.2 | | 2.6 | 2.9 | | | 2.3 | 280 |
| 285 | | | | | | | 3.6 | | | 3.1 | 3.2 | | | | 2.5 | | | | 285 |
| 290 | | | | | | | | | | 2.9 | 3.1 | | | | | | | | 290 |
| 295 | | | | | | | | | | 2.7 | 2.9 | | | | | | | | 295 |
| 300 | | | | | | | | | | 2.6 | 2.7 | | | | | | | | 300 |

TAB 131246 / 131254 / 131262

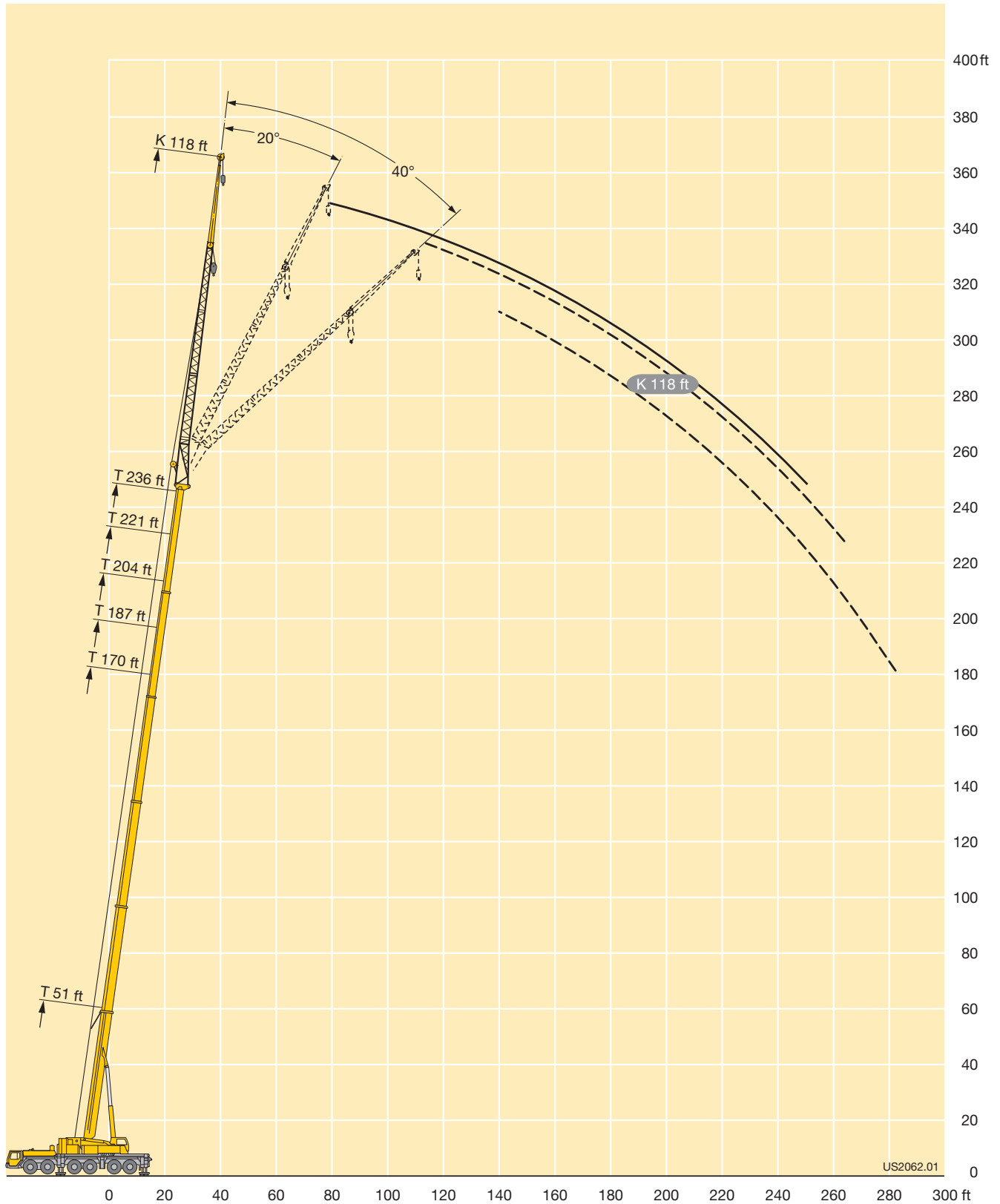

Lifting capacities Forces de levage

TNZK



| ft | 51 ft | | | 68 ft | | | 85 ft | | | 102 ft | | | 119 ft | | | 136 ft | | | ft |
|-----|-------|------|------|-------|------|------|-------|------|------|--------|------|------|--------|------|------|--------|------|------|-----|
| | 18 ft | | | 18 ft | | | 18 ft | | | 18 ft | | | 18 ft | | | 18 ft | | | |
| | 0° | 20° | 45° | 0° | 20° | 45° | 0° | 20° | 45° | 0° | 20° | 45° | 0° | 20° | 45° | 0° | 20° | 45° | |
| 10 | 135 | 108 | | | | | | | | | | | | | | | | | 10 |
| 12 | 135 | 107 | | 135 | 105 | | | | | | | | | | | | | | 12 |
| 14 | 132 | 102 | 82.5 | 135 | 104 | | | | | | | | | | | | | | 14 |
| 16 | 125 | 98.5 | 81 | 131 | 101 | 81 | 129 | 101 | | | | | | | | | | | 16 |
| 18 | 120 | 95 | 79 | 126 | 98 | 80 | 126 | 98.5 | 79 | | 96 | | | | | | | | 18 |
| 21 | 112 | 90 | 76.5 | 119 | 94 | 78 | 120 | 95 | 78 | 113 | 95 | 76.5 | | 91 | | | | | 21 |
| 24 | 105 | 86 | 74 | 112 | 90 | 75.5 | 114 | 91.5 | 76.5 | 112 | 92 | 76 | 108 | 90.5 | 75 | | | | 24 |
| 27 | 98.5 | 82 | 72 | 106 | 86.5 | 73.5 | 110 | 88.5 | 74.5 | 109 | 89 | 75.5 | 105 | 88 | 75 | 91 | 80 | | 27 |
| 30 | 93 | 78.5 | 70 | 101 | 83 | 72 | 105 | 85.5 | 73 | 105 | 86.5 | 74 | 102 | 86 | 74 | 90 | 80 | | 30 |
| 33 | 88 | 75.5 | 67.5 | 96.5 | 80 | 70.5 | 100 | 82.5 | 71.5 | 102 | 84 | 72.5 | 99.5 | 84 | 72.5 | 88 | 78.5 | 70 | 33 |
| 36 | 84 | 73 | 65.5 | 92 | 77.5 | 69 | 96.5 | 80 | 70 | 98 | 81.5 | 71 | 97 | 82 | 71.5 | 86.5 | 77 | 69 | 36 |
| 39 | 80 | 70 | 63.5 | 88.5 | 75.5 | 67.5 | 93 | 78 | 69 | 95 | 79.5 | 70 | 94.5 | 80 | 70.5 | 85 | 75.5 | 68.5 | 39 |
| 45 | 71.5 | 63 | 29 | 82 | 71 | 64 | 87 | 74 | 66.5 | 89 | 76 | 67.5 | 90 | 77 | 68.5 | 82.5 | 73 | 66.5 | 45 |
| 51 | 63 | 58.6 | 16.4 | 76 | 66 | 61 | 81.5 | 71 | 64 | 84 | 72.5 | 66 | 85.5 | 74 | 67 | 79.5 | 71 | 65.5 | 51 |
| 57 | 55.7 | 22.7 | | 70 | 62 | 35 | 77 | 67.5 | 61.5 | 79.5 | 69.5 | 64.5 | 82 | 71.5 | 65.5 | 75.5 | 68.5 | 64 | 57 |
| 63 | | | | 64 | 58.3 | 19.8 | 72.5 | 63.5 | 59.5 | 76 | 67 | 62.5 | 79 | 69.5 | 64 | 71.5 | 65 | 61.5 | 63 |
| 69 | | | | 58 | 39.6 | 12.2 | 68 | 60.5 | 40.4 | 72.5 | 64.5 | 60.5 | 76 | 67.5 | 62.5 | 67.5 | 62 | 59 | 69 |
| 75 | | | | | | | 63.5 | 58.1 | 21.7 | 68.5 | 62 | 59.1 | 71.5 | 65.5 | 61 | 64.5 | 59.5 | 56.8 | 75 |
| 81 | | | | | | | 59.1 | 56 | 16.1 | 63.5 | 59.5 | 46.1 | 65 | 63 | 59.8 | 61.5 | 57.1 | 55 | 81 |
| 87 | | | | | | | 54.1 | 46.5 | | 57.4 | 56.6 | 22.8 | 58.6 | 59.2 | 57.9 | 58.3 | 54.9 | 53.3 | 87 |
| 93 | | | | | | | | | | 51.8 | 52.3 | 19.5 | 53 | 53.6 | 53.9 | 54.7 | 52.8 | 51.7 | 93 |
| 99 | | | | | | | | | | 46.8 | 45.4 | 11.1 | 48 | 48.5 | 46.8 | 49.7 | 50.3 | 50 | 99 |
| 105 | | | | | | | | | | | | | 43.6 | 44 | 22.5 | 45.3 | 45.8 | 46 | 105 |
| 111 | | | | | | | | | | | | | 39.8 | 40.1 | 13.8 | 41.4 | 41.9 | 42 | 111 |
| 117 | | | | | | | | | | | | | 36.4 | 36.6 | 9.2 | 38 | 38.3 | 26.5 | 117 |
| 123 | | | | | | | | | | | | | 31.6 | 26.6 | | 34.9 | 35.2 | 16.6 | 123 |
| 129 | | | | | | | | | | | | | | | | 32.1 | 32.3 | 11.3 | 129 |
| 135 | | | | | | | | | | | | | | | | 29.7 | 26.8 | 8 | 135 |
| 141 | | | | | | | | | | | | | | | | 22.4 | | | 141 |

TAB 131430 / 131492 / 131540

Lifting capacities Forces de levage

TNZK



| ft | 153 ft | | | 170 ft | | | 187 ft | | | 204 ft | | | 221 ft | | | 236 ft | | | ft |
|-----|--------|------|------|--------|------|------|--------|------|------|--------|------|------|--------|------|------|--------|------|------|-----|
| | 18 ft | | | 18 ft | | | 18 ft | | | 18 ft | | | 18 ft | | | 18 ft | | | |
| | 0° | 20° | 45° | 0° | 20° | 45° | 0° | 20° | 45° | 0° | 20° | 45° | 0° | 20° | 45° | 0° | 20° | 45° | |
| 30 | 77.5 | 72.5 | | | | | | | | | | | | | | | | | 30 |
| 33 | 77.5 | 72 | | 62 | | | | | | | | | | | | | | | 33 |
| 36 | 77 | 71.5 | 66 | 62 | 62 | | 46.3 | | | | | | | | | | | | 36 |
| 39 | 76 | 70.5 | 65.5 | 62 | 62 | 60.5 | 46.3 | 46.3 | | | | | | | | | | | 39 |
| 45 | 71.5 | 68.5 | 64 | 59.9 | 60 | 60 | 46.3 | 46.3 | 46.3 | 38.8 | 38.8 | | | | | | | | 45 |
| 51 | 66 | 65.5 | 63 | 56.9 | 57.2 | 57 | 46.3 | 46.3 | 46.3 | 38.8 | 38.8 | 38.8 | 31.5 | 31.5 | | 23.4 | 23.4 | | 51 |
| 57 | 61 | 61 | 60.5 | 53.1 | 53.3 | 53.6 | 45.2 | 45.6 | 45.8 | 38.4 | 38.4 | 38.4 | 31.5 | 31.5 | 31.5 | 23.4 | 23.4 | 23.4 | 57 |
| 63 | 55.9 | 55.8 | 56.2 | 49.4 | 49.5 | 50 | 42.8 | 43.3 | 43.7 | 37 | 37 | 37.3 | 31.2 | 31.1 | 31.2 | 23.4 | 23.4 | 23.4 | 63 |
| 69 | 51.2 | 51.2 | 51.6 | 45.9 | 46 | 46.4 | 40.1 | 40.4 | 40.9 | 35.1 | 35.3 | 35.5 | 30.3 | 30.2 | 30.4 | 23.4 | 23.4 | 23.4 | 69 |
| 75 | 47.1 | 47.1 | 47.4 | 42.5 | 42.7 | 43 | 37.6 | 37.8 | 38.3 | 33 | 33.5 | 33.6 | 29 | 29 | 29.2 | 23.3 | 23.3 | 23.3 | 75 |
| 81 | 43.6 | 43.7 | 43.7 | 39.2 | 39.5 | 39.8 | 35.2 | 35.4 | 35.8 | 31.1 | 31.6 | 31.8 | 27.6 | 27.6 | 27.8 | 22.8 | 22.8 | 23 | 81 |
| 87 | 40.5 | 40.6 | 40.6 | 36.2 | 36.4 | 36.8 | 32.9 | 33.1 | 33.5 | 29.3 | 29.7 | 30 | 26.2 | 26.3 | 26.5 | 21.8 | 21.8 | 22.1 | 87 |
| 93 | 37.5 | 37.6 | 37.7 | 33.7 | 33.9 | 34.2 | 30.7 | 30.9 | 31.2 | 27.7 | 27.9 | 28.2 | 24.9 | 25 | 25.3 | 20.9 | 20.9 | 21.2 | 93 |
| 99 | 34.8 | 34.9 | 35 | 31.2 | 31.5 | 31.8 | 28.7 | 28.9 | 29.1 | 26.1 | 26.2 | 26.6 | 23.6 | 23.8 | 24.1 | 20 | 20.1 | 20.3 | 99 |
| 105 | 32.2 | 32.3 | 32.4 | 29 | 29.2 | 29.5 | 26.7 | 26.9 | 27.2 | 24.5 | 24.7 | 25 | 22.3 | 22.6 | 23 | 19.1 | 19.2 | 19.5 | 105 |
| 111 | 29.7 | 29.8 | 30 | 26.9 | 27.1 | 27.3 | 24.9 | 25.1 | 25.4 | 23 | 23.2 | 23.4 | 21.2 | 21.4 | 21.7 | 18.3 | 18.5 | 18.7 | 111 |
| 117 | 27.8 | 28 | 28.1 | 24.9 | 25.1 | 25.3 | 23.1 | 23.3 | 23.6 | 21.6 | 21.7 | 21.9 | 19.9 | 20.2 | 20.5 | 17.4 | 17.6 | 17.9 | 117 |
| 123 | 26.1 | 26.2 | 26.4 | 23 | 23.2 | 23.4 | 21.5 | 21.7 | 21.9 | 20.2 | 20.3 | 20.5 | 18.8 | 19 | 19.3 | 16.4 | 16.6 | 16.9 | 123 |
| 129 | 24.5 | 24.6 | 24.3 | 21.5 | 21.6 | 21.8 | 19.9 | 20.1 | 20.3 | 18.8 | 19 | 19.2 | 17.7 | 17.9 | 18.2 | 15.5 | 15.7 | 15.9 | 129 |
| 135 | 23 | 23.1 | 18.8 | 20.1 | 20.3 | 20.3 | 18.4 | 18.6 | 18.7 | 17.6 | 17.7 | 17.9 | 16.7 | 16.8 | 17.1 | 14.5 | 14.7 | 15 | 135 |
| 141 | 21.5 | 21.6 | 13.2 | 18.8 | 19 | 19 | 17 | 17.2 | 17.4 | 16.5 | 16.6 | 16.7 | 15.6 | 15.8 | 16 | 13.7 | 13.8 | 14.1 | 141 |
| 147 | 20.1 | 20.2 | 9.6 | 17.6 | 17.7 | 17.5 | 15.9 | 16.1 | 16.2 | 15.6 | 15.6 | 15.8 | 14.6 | 14.8 | 15 | 12.8 | 13 | 13.2 | 147 |
| 153 | 16.8 | 16.9 | 7.1 | 16.4 | 16.6 | 14.9 | 14.9 | 15 | 15.1 | 14.7 | 14.8 | 14.9 | 13.6 | 13.8 | 13.9 | 12 | 12.2 | 12.4 | 153 |
| 159 | | | | 15.3 | 15.4 | 11 | 13.8 | 14 | 14 | 14 | 14 | 14.1 | 12.6 | 12.8 | 12.9 | 11.2 | 11.4 | 11.6 | 159 |
| 165 | | | | 14.2 | 14.3 | | 12.9 | 12.9 | 13 | 13.1 | 13.3 | 13.3 | 11.7 | 11.8 | 12 | 10.5 | 10.6 | 10.8 | 165 |
| 171 | | | | | | | 11.9 | 12 | 11.9 | 12.3 | 12.4 | 12.4 | 10.9 | 11.1 | 11.2 | 9.8 | 9.9 | 10 | 171 |
| 177 | | | | | | | 11 | 11 | 9.8 | 11.5 | 11.6 | 11.6 | 10.2 | 10.4 | 10.4 | 9.2 | 9.3 | 9.4 | 177 |
| 183 | | | | | | | 10.1 | 10.1 | 7.7 | 10.8 | 10.8 | 10.8 | 9.5 | 9.6 | 9.7 | 8.6 | 8.8 | 8.8 | 183 |
| 189 | | | | | | | | | | 10 | 10.1 | 10 | 8.9 | 8.9 | 9 | 8.1 | 8.2 | 8.2 | 189 |
| 195 | | | | | | | | | | 9.3 | 9.4 | 8.8 | 8.2 | 8.3 | 8.3 | 7.5 | 7.7 | 7.6 | 195 |
| 201 | | | | | | | | | | 8.6 | 8.7 | 7.3 | 7.6 | 7.7 | 7.7 | 7 | 7.1 | 7.1 | 201 |
| 207 | | | | | | | | | | | | | 7 | 7 | 7 | 6.5 | 6.5 | 6.5 | 207 |
| 213 | | | | | | | | | | | | | 6.4 | 6.4 | 6.4 | 6 | 6 | 5.9 | 213 |
| 219 | | | | | | | | | | | | | 5.8 | | | 5.4 | 5.5 | 5.4 | 219 |
| 225 | | | | | | | | | | | | | | | | 4.9 | 5 | 4.8 | 225 |
| 231 | | | | | | | | | | | | | | | | 4.4 | 4.5 | | 231 |

TAB 131430 / 131492 / 131540

Lifting capacities Forces de levage

TNZK



| ft | 51 ft | | | 170 ft | | | 187 ft | | | 204 ft | | | 221 ft | | | 236 ft | | | ft |
|-----|-------|------|------|--------|------|------|--------|------|------|--------|------|------|--------|------|------|--------|------|------|-----|
| | 40 ft | | | 40 ft | | | 40 ft | | | 40 ft | | | 40 ft | | | 40 ft | | | |
| | 0° | 20° | 45° | 0° | 20° | 45° | 0° | 20° | 45° | 0° | 20° | 45° | 0° | 20° | 45° | 0° | 20° | 45° | |
| 11 | 40 | | | | | | | | | | | | | | | | | | 11 |
| 12 | 39.8 | | | | | | | | | | | | | | | | | | 12 |
| 13 | 39.4 | | | | | | | | | | | | | | | | | | 13 |
| 14 | 39.1 | | | | | | | | | | | | | | | | | | 14 |
| 15 | 38.8 | | | | | | | | | | | | | | | | | | 15 |
| 16 | 38.5 | | | | | | | | | | | | | | | | | | 16 |
| 17 | 38.2 | | | | | | | | | | | | | | | | | | 17 |
| 18 | 37.9 | 32.7 | | | | | | | | | | | | | | | | | 18 |
| 20 | 37.3 | 32.6 | | | | | | | | | | | | | | | | | 20 |
| 22 | 36.6 | 32 | | | | | | | | | | | | | | | | | 22 |
| 24 | 36 | 31.2 | | | | | | | | | | | | | | | | | 24 |
| 26 | 35.3 | 30.1 | | | | | | | | | | | | | | | | | 26 |
| 28 | 34.7 | 29.2 | | | | | | | | | | | | | | | | | 28 |
| 30 | 33.9 | 28.3 | | | | | | | | | | | | | | | | | 30 |
| 32 | 32.6 | 27.5 | 21.1 | 39.8 | | | | | | | | | | | | | | | 32 |
| 34 | 31.2 | 26.8 | 21 | 39.8 | | | | | | | | | | | | | | | 34 |
| 36 | 29.9 | 26.1 | 20.9 | 39.7 | | | 34.7 | | | | | | | | | | | | 36 |
| 38 | 28.6 | 25.5 | 20.6 | 39.5 | | | 34.7 | | | | | | | | | | | | 38 |
| 40 | 27.4 | 24.9 | 20.3 | 39.2 | | | 34.7 | | | | | | | | | | | | 40 |
| 45 | 24.5 | 23.5 | 19.8 | 38.6 | 31.8 | | 34.5 | | | 28.9 | | | 22.8 | | | | | | 45 |
| 50 | 22.1 | 22.5 | 19.3 | 37.9 | 30.9 | | 34.2 | 30.1 | | 28.9 | | | 22.8 | | | 19.2 | | | 50 |
| 55 | 20 | 21.3 | 18.9 | 37.2 | 29.9 | 21.1 | 33.9 | 29.6 | | 28.8 | 27.5 | | 22.8 | | | 19.2 | | | 55 |
| 60 | 18 | 19.8 | 18.7 | 36.4 | 28.9 | 21.1 | 33.5 | 28.8 | | 28.6 | 27.4 | | 22.8 | | | 19.2 | | | 60 |
| 65 | 16.3 | 17.8 | 18.4 | 35.7 | 28 | 20.8 | 33 | 28 | 20.6 | 28.4 | 27 | | 22.8 | 23 | | 19.2 | | | 65 |
| 70 | 14.9 | 16.1 | 16.6 | 35 | 27.2 | 20.5 | 32.5 | 27.2 | 20.5 | 28.1 | 26.4 | 20.1 | 22.8 | 22.9 | | 19.2 | 19.2 | | 70 |
| 75 | 13.7 | 14.5 | | 34.3 | 26.5 | 20.3 | 31.9 | 26.5 | 20.3 | 27.9 | 25.8 | 20 | 22.7 | 22.6 | 19.4 | 19.2 | 19.2 | | 75 |
| 80 | | | | 33.4 | 25.8 | 20 | 31.3 | 25.8 | 20 | 27.5 | 25.2 | 19.9 | 22.5 | 22.2 | 19.4 | 19.1 | 19.1 | | 80 |
| 85 | | | | 32.2 | 25.2 | 19.8 | 30.2 | 25.2 | 19.8 | 26.5 | 24.6 | 19.7 | 21.8 | 21.7 | 19.3 | 18.8 | 19 | 18.7 | 85 |
| 90 | | | | 30.7 | 24.5 | 19.6 | 28.8 | 24.6 | 19.6 | 25.4 | 24.2 | 19.5 | 21.2 | 21.1 | 19.2 | 18.4 | 18.5 | 18.6 | 90 |
| 95 | | | | 29.3 | 24 | 19.5 | 27.4 | 24.1 | 19.5 | 24.3 | 23.7 | 19.3 | 20.6 | 20.5 | 19.1 | 17.8 | 18 | 18.3 | 95 |
| 100 | | | | 27.9 | 23.4 | 19.3 | 26.1 | 23.6 | 19.3 | 23.2 | 23.2 | 19.2 | 20 | 19.9 | 19 | 17.3 | 17.4 | 17.9 | 100 |
| 105 | | | | 26.7 | 23 | 19.2 | 24.8 | 23.2 | 19.1 | 22.2 | 22.6 | 19.1 | 19.4 | 19.2 | 18.9 | 16.8 | 17 | 17.4 | 105 |
| 110 | | | | 25.4 | 22.5 | 19 | 23.7 | 22.7 | 19 | 21.2 | 21.9 | 19 | 18.8 | 18.6 | 18.6 | 16.3 | 16.5 | 16.9 | 110 |
| 115 | | | | 24.2 | 22.1 | 18.9 | 22.6 | 22.2 | 18.8 | 20.3 | 21 | 18.9 | 18.2 | 18 | 18.1 | 15.8 | 16 | 16.4 | 115 |
| 120 | | | | 23 | 21.8 | 18.8 | 21.5 | 21.6 | 18.7 | 19.4 | 20 | 18.8 | 17.5 | 17.4 | 17.5 | 15.3 | 15.6 | 15.9 | 120 |
| 125 | | | | 22.1 | 21.4 | 18.7 | 20.4 | 20.9 | 18.6 | 18.5 | 19.1 | 18.7 | 16.8 | 16.9 | 17 | 14.8 | 15.1 | 15.4 | 125 |
| 130 | | | | 21.1 | 20.9 | 18.6 | 19.2 | 19.8 | 18.5 | 17.6 | 18.2 | 18.7 | 16.1 | 16.3 | 16.4 | 14.2 | 14.5 | 14.9 | 130 |
| 135 | | | | 20.2 | 20.1 | 18.6 | 18.1 | 18.8 | 18.5 | 16.8 | 17.3 | 18 | 15.5 | 15.8 | 15.9 | 13.5 | 14 | 14.4 | 135 |
| 140 | | | | 19.3 | 19.3 | 18.5 | 17.1 | 17.7 | 18.1 | 16 | 16.4 | 17.1 | 14.8 | 15.3 | 15.4 | 12.9 | 13.4 | 14 | 140 |
| 145 | | | | 18.4 | 18.5 | 18.4 | 16.3 | 16.7 | 17.3 | 15.2 | 15.6 | 16.2 | 14.1 | 14.6 | 14.9 | 12.3 | 12.8 | 13.5 | 145 |
| 150 | | | | 17.6 | 17.7 | 17.9 | 15.6 | 15.7 | 16.4 | 14.4 | 14.8 | 15.4 | 13.5 | 14 | 14.5 | 11.8 | 12.2 | 12.9 | 150 |
| 155 | | | | 16.8 | 17 | 17.3 | 15 | 15 | 15.4 | 13.6 | 14 | 14.6 | 12.9 | 13.4 | 13.9 | 11.2 | 11.7 | 12.3 | 155 |
| 160 | | | | 16.1 | 16.2 | 16.6 | 14.4 | 14.4 | 14.6 | 12.9 | 13.3 | 13.7 | 12.3 | 12.8 | 13.2 | 10.6 | 11.1 | 11.7 | 160 |
| 165 | | | | 15.5 | 15.6 | 15.9 | 13.9 | 13.8 | 14 | 12.4 | 12.6 | 13 | 11.7 | 12.2 | 12.6 | 10.1 | 10.5 | 11.1 | 165 |
| 170 | | | | 15 | 15 | 15.3 | 13.3 | 13.2 | 13.4 | 11.9 | 12.1 | 12.4 | 11.1 | 11.5 | 11.9 | 9.6 | 10 | 10.5 | 170 |
| 175 | | | | 14.4 | 14.5 | 14.7 | 12.8 | 12.6 | 12.9 | 11.5 | 11.6 | 11.8 | 10.5 | 10.9 | 11.3 | 9.1 | 9.5 | 10 | 175 |
| 180 | | | | 13.8 | 13.9 | | 12.3 | 12.1 | 12.3 | 11 | 11.2 | 11.3 | 9.9 | 10.3 | 10.7 | 8.6 | 9 | 9.4 | 180 |
| 185 | | | | 13.3 | 13.4 | | 11.8 | 11.6 | 11.8 | 10.6 | 10.7 | 10.8 | 9.4 | 9.8 | 10.1 | 8.1 | 8.6 | 8.9 | 185 |
| 190 | | | | 12.7 | 12.9 | | 11.3 | 11.1 | 11.2 | 10.2 | 10.3 | 10.4 | 8.8 | 9.3 | 9.5 | 7.7 | 8.1 | 8.5 | 190 |
| 195 | | | | 10.2 | | | 10.9 | 10.7 | | 9.8 | 9.9 | 9.9 | 8.3 | 8.8 | 9 | 7.4 | 7.7 | 8 | 195 |
| 200 | | | | | | | 10.4 | 10.2 | | 9.4 | 9.5 | 9.5 | 7.8 | 8.3 | 8.4 | 7 | 7.2 | 7.6 | 200 |
| 205 | | | | | | | 10 | 9.8 | | 9 | 9.1 | | 7.4 | 7.9 | 7.9 | 6.7 | 6.8 | 7.2 | 205 |
| 210 | | | | | | | | | | 8.6 | 8.7 | | 7 | 7.4 | 7.4 | 6.3 | 6.4 | 6.8 | 210 |
| 215 | | | | | | | | | | 8.2 | 8.3 | | 6.6 | 7 | 6.9 | 5.9 | 6 | 6.3 | 215 |
| 220 | | | | | | | | | | 7.8 | 7.9 | | 6.3 | 6.5 | 6.4 | 5.6 | 5.7 | 5.9 | 220 |
| 225 | | | | | | | | | | | | | 5.9 | 6.1 | | 5.2 | 5.3 | 5.4 | 225 |
| 230 | | | | | | | | | | | | | 5.5 | 5.7 | | 4.8 | 5 | 5 | 230 |
| 235 | | | | | | | | | | | | | 5.2 | 5.3 | | 4.4 | 4.6 | 4.5 | 235 |
| 240 | | | | | | | | | | | | | 4.8 | 4.9 | | 4.1 | 4.2 | | 240 |
| 245 | | | | | | | | | | | | | | | | 3.7 | 3.8 | | 245 |
| 250 | | | | | | | | | | | | | | | | 3.4 | 3.4 | | 250 |
| 255 | | | | | | | | | | | | | | | | 3 | 3.1 | | 255 |

TAB 131366 / 131407 / 131418

Lifting capacities Forces de levage

TNZK



| ft | 51 ft | | | 170 ft | | | 187 ft | | | 204 ft | | | 221 ft | | | 236 ft | | | ft |
|-----|-------|------|------|--------|------|------|--------|------|------|--------|------|------|--------|------|-----|--------|------|-----|-----|
| | 72 ft | | | 72 ft | | | 72 ft | | | 72 ft | | | 72 ft | | | 72 ft | | | |
| | 0° | 20° | 45° | 0° | 20° | 45° | 0° | 20° | 45° | 0° | 20° | 45° | 0° | 20° | 45° | 0° | 20° | 45° | |
| 13 | 17 | | | | | | | | | | | | | | | | | | 13 |
| 14 | 17 | | | | | | | | | | | | | | | | | | 14 |
| 15 | 17 | | | | | | | | | | | | | | | | | | 15 |
| 16 | 17 | | | | | | | | | | | | | | | | | | 16 |
| 17 | 17 | | | | | | | | | | | | | | | | | | 17 |
| 18 | 17 | | | | | | | | | | | | | | | | | | 18 |
| 20 | 17 | | | | | | | | | | | | | | | | | | 20 |
| 22 | 17 | | | | | | | | | | | | | | | | | | 22 |
| 24 | 17 | | | | | | | | | | | | | | | | | | 24 |
| 26 | 16.9 | | | | | | | | | | | | | | | | | | 26 |
| 28 | 16.8 | | | | | | | | | | | | | | | | | | 28 |
| 30 | 16.6 | | | | | | | | | | | | | | | | | | 30 |
| 32 | 16.4 | | | | | | | | | | | | | | | | | | 32 |
| 34 | 16.2 | | | | | | | | | | | | | | | | | | 34 |
| 36 | 16 | 14.6 | | 17 | | | | | | | | | | | | | | | 36 |
| 38 | 15.9 | 14.6 | | 17 | | | 16 | | | | | | | | | | | | 38 |
| 40 | 15.7 | 14.5 | | 17 | | | 16 | | | | | | | | | | | | 40 |
| 45 | 15.1 | 14 | | 17 | | | 16 | | | 14.1 | | | | | | | | | 45 |
| 50 | 14.6 | 13.4 | | 17 | | | 16 | | | 14.1 | | | 12.9 | | | | | | 50 |
| 55 | 14 | 12.9 | 10.7 | 16.9 | | | 16 | | | 14.1 | | | 12.9 | | | 11.4 | | | 55 |
| 60 | 13.5 | 12.4 | 10.6 | 16.9 | | | 16 | | | 14.1 | | | 12.9 | | | 11.4 | | | 60 |
| 65 | 13 | 12 | 10.4 | 16.7 | 14.3 | | 15.8 | | | 14.1 | | | 12.9 | | | 11.4 | | | 65 |
| 70 | 12.5 | 11.6 | 10 | 16.4 | 14.2 | | 15.6 | 13.8 | | 14.1 | | | 12.8 | | | 11.4 | | | 70 |
| 75 | 12.2 | 11.2 | 9.7 | 16.2 | 14 | | 15.4 | 13.7 | | 14.1 | 12.6 | | 12.7 | | | 11.4 | | | 75 |
| 80 | 11.9 | 10.9 | 9.5 | 16 | 13.7 | | 15.2 | 13.4 | | 14 | 12.6 | | 12.6 | | | 11.4 | | | 80 |
| 85 | 11.6 | 10.7 | 9.3 | 15.7 | 13.4 | 10.7 | 15 | 13.1 | | 13.9 | 12.6 | | 12.5 | 11.6 | | 11.4 | | | 85 |
| 90 | 11.2 | 10.4 | 9.2 | 15.4 | 13.2 | 10.5 | 14.8 | 12.9 | 10.4 | 13.7 | 12.4 | | 12.4 | 11.6 | | 11.4 | 10.7 | | 90 |
| 95 | 10.8 | 10.1 | 9.2 | 15.1 | 12.9 | 10.3 | 14.6 | 12.7 | 10.3 | 13.6 | 12.2 | 10.1 | 12.3 | 11.5 | | 11.3 | 10.7 | | 95 |
| 100 | 10.3 | 9.9 | 9.2 | 14.9 | 12.6 | 10.2 | 14.4 | 12.5 | 10.2 | 13.4 | 12 | 10.1 | 12.3 | 11.3 | 9.8 | 11.2 | 10.7 | | 100 |
| 105 | 9.6 | 9.7 | | 14.6 | 12.4 | 10 | 14.2 | 12.3 | 10 | 13.3 | 11.8 | 10 | 12.2 | 11.2 | 9.8 | 11.1 | 10.6 | | 105 |
| 110 | 9 | 9.4 | | 14.3 | 12.2 | 9.9 | 13.9 | 12 | 9.9 | 13.2 | 11.6 | 9.9 | 12.1 | 11 | 9.7 | 11.1 | 10.5 | 9.4 | 110 |
| 115 | | | | 14.1 | 12 | 9.8 | 13.7 | 11.8 | 9.8 | 13 | 11.5 | 9.8 | 12 | 10.9 | 9.6 | 11 | 10.4 | 9.3 | 115 |
| 120 | | | | 13.8 | 11.8 | 9.7 | 13.5 | 11.7 | 9.7 | 12.8 | 11.3 | 9.7 | 11.9 | 10.8 | 9.5 | 10.9 | 10.3 | 9.2 | 120 |
| 125 | | | | 13.5 | 11.6 | 9.6 | 13.3 | 11.5 | 9.6 | 12.6 | 11.2 | 9.6 | 11.8 | 10.6 | 9.4 | 10.9 | 10.2 | 9.1 | 125 |
| 130 | | | | 13.2 | 11.4 | 9.5 | 13.1 | 11.3 | 9.5 | 12.5 | 11 | 9.5 | 11.7 | 10.5 | 9.3 | 10.8 | 10.1 | 9.1 | 130 |
| 135 | | | | 13 | 11.3 | 9.4 | 12.8 | 11.2 | 9.5 | 12.3 | 10.8 | 9.4 | 11.6 | 10.4 | 9.3 | 10.7 | 10 | 9 | 135 |
| 140 | | | | 12.7 | 11.1 | 9.4 | 12.6 | 11 | 9.4 | 12.2 | 10.7 | 9.3 | 11.4 | 10.3 | 9.2 | 10.6 | 9.9 | 8.9 | 140 |
| 145 | | | | 12.5 | 11 | 9.3 | 12.4 | 10.9 | 9.3 | 12 | 10.7 | 9.3 | 11.3 | 10.2 | 9.1 | 10.4 | 9.9 | 8.9 | 145 |
| 150 | | | | 12.3 | 10.9 | 9.3 | 12.2 | 10.8 | 9.2 | 11.8 | 10.6 | 9.2 | 11.2 | 10.2 | 9.1 | 10.1 | 9.7 | 8.8 | 150 |
| 155 | | | | 12.1 | 10.8 | 9.2 | 12.1 | 10.7 | 9.2 | 11.7 | 10.5 | 9.2 | 11 | 10.1 | 9 | 9.7 | 9.6 | 8.8 | 155 |
| 160 | | | | 12 | 10.6 | 9.2 | 11.9 | 10.7 | 9.1 | 11.5 | 10.4 | 9.1 | 10.8 | 10 | 9 | 9.3 | 9.5 | 8.7 | 160 |
| 165 | | | | 11.8 | 10.4 | 9.2 | 11.7 | 10.6 | 9.1 | 11.3 | 10.4 | 9.1 | 10.4 | 9.9 | 8.9 | 8.9 | 9.4 | 8.7 | 165 |
| 170 | | | | 11.7 | 10.3 | 9.2 | 11.5 | 10.5 | 9.1 | 10.8 | 10.2 | 9.1 | 10 | 9.8 | 8.9 | 8.5 | 9.3 | 8.6 | 170 |
| 175 | | | | 11.5 | 10.2 | 9.2 | 11.2 | 10.4 | 9.1 | 10.4 | 10.1 | 9.1 | 9.6 | 9.7 | 8.9 | 8.1 | 9 | 8.6 | 175 |
| 180 | | | | 11.3 | 10.1 | 9.2 | 10.8 | 10.2 | 9.1 | 9.9 | 9.9 | 9.1 | 9.1 | 9.6 | 8.9 | 7.7 | 8.6 | 8.6 | 180 |
| 185 | | | | 11.1 | 10 | 9.2 | 10.3 | 10 | 9.1 | 9.4 | 9.7 | 9.1 | 8.7 | 9.4 | 8.9 | 7.3 | 8.2 | 8.6 | 185 |
| 190 | | | | 10.9 | 9.8 | 9.2 | 9.9 | 9.8 | 9.1 | 8.9 | 9.6 | 9.1 | 8.3 | 9.1 | 8.9 | 7 | 7.8 | 8.6 | 190 |
| 195 | | | | 10.6 | 9.7 | 9.2 | 9.6 | 9.6 | 9.1 | 8.5 | 9.1 | 9.1 | 7.9 | 8.7 | 8.9 | 6.7 | 7.4 | 8.2 | 195 |
| 200 | | | | 10.4 | 9.6 | 9.2 | 9.2 | 9.3 | 9.1 | 8.1 | 8.6 | 9 | 7.5 | 8.2 | 8.7 | 6.3 | 7 | 7.8 | 200 |
| 205 | | | | 10.1 | 9.5 | 9.2 | 8.9 | 9 | 9.1 | 7.8 | 8.2 | 8.7 | 7.1 | 7.8 | 8.4 | 6 | 6.6 | 7.3 | 205 |
| 210 | | | | 9.7 | 9.5 | | 8.5 | 8.6 | 8.9 | 7.4 | 7.8 | 8.2 | 6.7 | 7.4 | 7.9 | 5.8 | 6.3 | 6.9 | 210 |
| 215 | | | | 9.4 | 9.3 | | 8.2 | 8.3 | 8.4 | 7.2 | 7.5 | 7.8 | 6.4 | 7 | 7.4 | 5.4 | 6 | 6.5 | 215 |
| 220 | | | | 9 | 9.1 | | 7.9 | 7.9 | 8 | 6.9 | 7.1 | 7.5 | 6 | 6.6 | 6.9 | 5.1 | 5.7 | 6.1 | 220 |
| 225 | | | | | | | 7.5 | 7.6 | | 6.6 | 6.8 | 7.1 | 5.7 | 6.2 | 6.5 | 4.8 | 5.4 | 5.7 | 225 |
| 230 | | | | | | | 7.2 | 7.3 | | 6.4 | 6.5 | 6.7 | 5.5 | 5.8 | 6 | 4.5 | 5.1 | 5.4 | 230 |
| 235 | | | | | | | 6.9 | 6.9 | | 6.1 | 6.3 | 6.4 | 5.1 | 5.5 | 5.6 | 4.2 | 4.8 | 5 | 235 |
| 240 | | | | | | | 6.6 | | | 5.9 | 6 | | 4.8 | 5.1 | 5.2 | 3.9 | 4.4 | 4.6 | 240 |
| 245 | | | | | | | | | | 5.7 | 5.8 | | 4.6 | 4.8 | 4.8 | 3.5 | 4 | 4.2 | 245 |
| 250 | | | | | | | | | | 5.5 | 5.6 | | 4.3 | 4.5 | | 3.2 | 3.7 | 3.8 | 250 |
| 255 | | | | | | | | | | 5.2 | 5.3 | | 3.9 | 4.2 | | 2.9 | 3.4 | 3.3 | 255 |
| 260 | | | | | | | | | | | | | 3.6 | 3.8 | | 2.6 | 3 | 2.9 | 260 |
| 265 | | | | | | | | | | | | | 3.3 | 3.5 | | 2.4 | 2.7 | | 265 |
| 270 | | | | | | | | | | | | | 3 | 3.1 | | | | | 270 |
| 275 | | | | | | | | | | | | | 2.7 | 2.8 | | | | | 275 |

TAB 131366 / 131407 / 131418

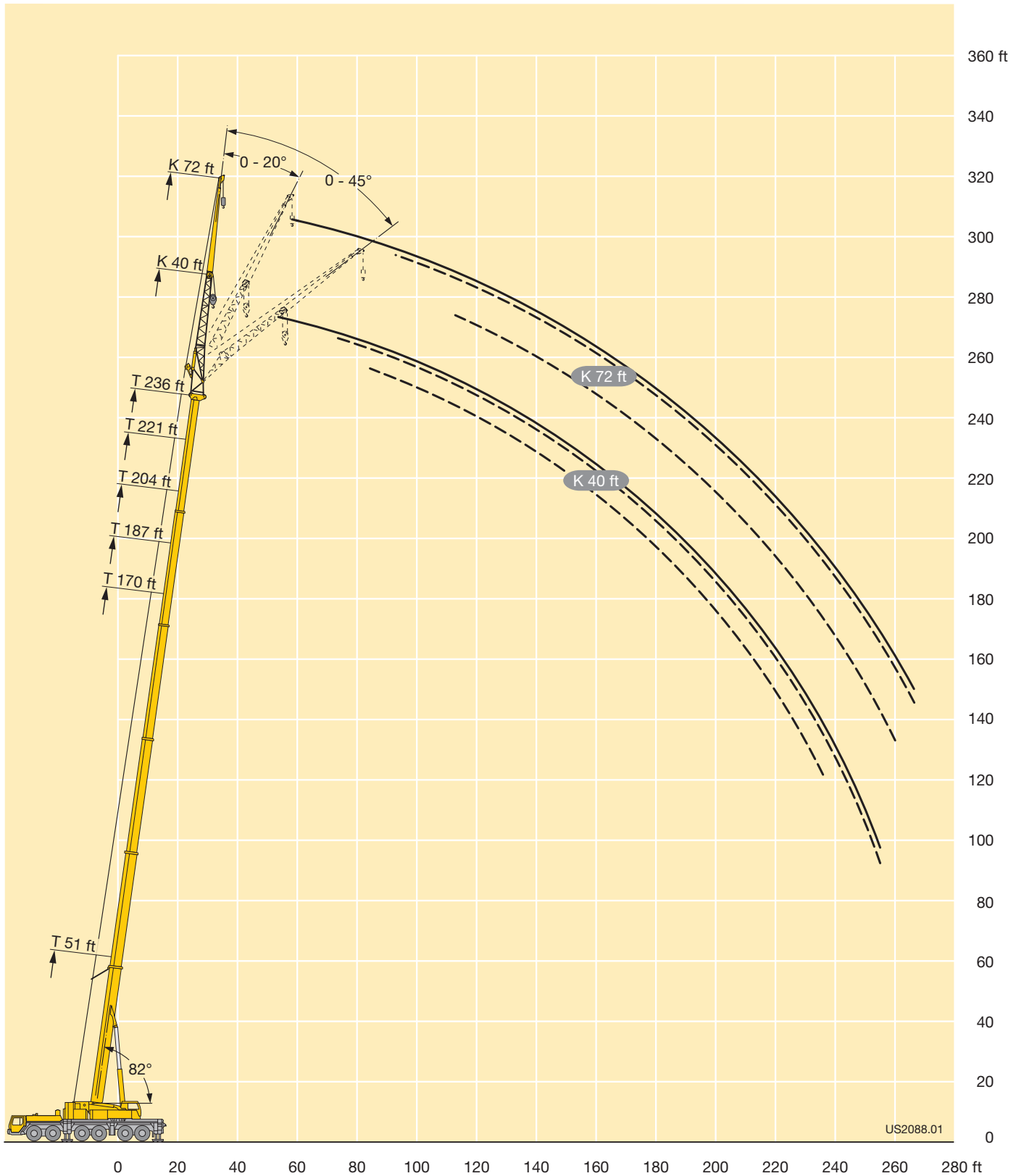

US2088.01

Lifting capacities Forces de levage

TNZK



| ft | 51 ft | | | 170 ft | | | 187 ft | | | 204 ft | | | 221 ft | | | 236 ft | | | ft |
|-----|-------|-----|-----|--------|-----|-----|--------|-----|-----|--------|-----|-----|--------|-----|-----|--------|-----|-----|-----|
| | 95 ft | | | 95 ft | | | 95 ft | | | 95 ft | | | 95 ft | | | 95 ft | | | |
| | 0° | 20° | 45° | 0° | 20° | 45° | 0° | 20° | 45° | 0° | 20° | 45° | 0° | 20° | 45° | 0° | 20° | 45° | |
| 16 | 12.9 | | | | | | | | | | | | | | | | | | 16 |
| 17 | 12.9 | | | | | | | | | | | | | | | | | | 17 |
| 18 | 12.9 | | | | | | | | | | | | | | | | | | 18 |
| 20 | 12.9 | | | | | | | | | | | | | | | | | | 20 |
| 22 | 12.9 | | | | | | | | | | | | | | | | | | 22 |
| 24 | 12.9 | | | | | | | | | | | | | | | | | | 24 |
| 26 | 12.9 | | | | | | | | | | | | | | | | | | 26 |
| 28 | 12.8 | | | | | | | | | | | | | | | | | | 28 |
| 30 | 12.8 | | | | | | | | | | | | | | | | | | 30 |
| 32 | 12.8 | | | | | | | | | | | | | | | | | | 32 |
| 34 | 12.7 | | | | | | | | | | | | | | | | | | 34 |
| 36 | 12.6 | | | | | | | | | | | | | | | | | | 36 |
| 38 | 12.4 | | | | | | | | | | | | | | | | | | 38 |
| 40 | 12.1 | | | | | | | | | | | | | | | | | | 40 |
| 45 | 11.5 | | | 12.9 | | | 11.4 | | | | | | | | | | | | 45 |
| 50 | 11 | 9.9 | | 12.9 | | | 11.4 | | 9.9 | | | | | | | | | | 50 |
| 55 | 10.5 | 9.7 | | 12.8 | | | 11.4 | | 9.9 | | | | 8.7 | | | | | | 55 |
| 60 | 10 | 9.2 | | 12.8 | | | 11.4 | | 9.9 | | | | 8.7 | | | | | | 60 |
| 65 | 9.6 | 8.7 | | 12.7 | | | 11.4 | | 9.9 | | | | 8.7 | | | | | | 65 |
| 70 | 9.2 | 8.3 | | 12.7 | | | 11.4 | | 9.9 | | | | 8.7 | | | 7.5 | | | 70 |
| 75 | 8.8 | 7.9 | 6.3 | 12.4 | 9.7 | | 11.4 | | 9.9 | | | | 8.7 | | | 7.5 | | | 75 |
| 80 | 8.5 | 7.6 | 6.3 | 12.1 | 9.7 | | 11.4 | | 9.9 | | | | 8.7 | | | 7.5 | | | 80 |
| 85 | 8.1 | 7.3 | 6.1 | 11.7 | 9.5 | | 11.3 | 9 | 9.9 | | | | 8.7 | | | 7.5 | | | 85 |
| 90 | 7.8 | 7 | 6 | 11.4 | 9.2 | | 11.1 | 8.9 | 9.9 | 8.3 | | | 8.7 | | | 7.5 | | | 90 |
| 95 | 7.6 | 6.8 | 5.8 | 11.1 | 9 | | 10.8 | 8.7 | 9.9 | 8.2 | | | 8.7 | 7.5 | | 7.5 | | | 95 |
| 100 | 7.3 | 6.6 | 5.6 | 10.8 | 8.7 | 6.3 | 10.5 | 8.5 | 9.7 | 8.1 | | | 8.7 | 7.5 | | 7.5 | 7 | | 100 |
| 105 | 7 | 6.3 | 5.6 | 10.5 | 8.5 | 6.3 | 10.3 | 8.3 | 9.6 | 8 | | | 8.7 | 7.5 | | 7.5 | 7 | | 105 |
| 110 | 6.8 | 6.1 | 5.5 | 10.3 | 8.3 | 6.3 | 10 | 8.2 | 6.1 | 9.4 | 7.8 | | 8.6 | 7.3 | | 7.5 | 6.9 | | 110 |
| 115 | 6.6 | 6 | 5.4 | 10 | 8.1 | 6.2 | 9.8 | 8 | 6.1 | 9.2 | 7.6 | 5.8 | 8.4 | 7.2 | | 7.5 | 6.8 | | 115 |
| 120 | 6.4 | 5.8 | 5.4 | 9.8 | 7.9 | 6.1 | 9.6 | 7.8 | 6 | 9 | 7.5 | 5.8 | 8.3 | 7 | 5.8 | 7.5 | 6.7 | | 120 |
| 125 | 6.2 | 5.7 | | 9.5 | 7.7 | 6 | 9.4 | 7.6 | 6 | 8.8 | 7.3 | 5.8 | 8.1 | 6.9 | 5.8 | 7.5 | 6.5 | | 125 |
| 130 | 6 | 5.7 | | 9.3 | 7.6 | 5.9 | 9.1 | 7.5 | 5.9 | 8.6 | 7.2 | 5.8 | 8 | 6.8 | 5.8 | 7.4 | 6.5 | 5.6 | 130 |
| 135 | | | | 9.1 | 7.4 | 5.8 | 8.9 | 7.3 | 5.9 | 8.5 | 7.1 | 5.8 | 7.8 | 6.7 | 5.7 | 7.3 | 6.4 | 5.6 | 135 |
| 140 | | | | 8.9 | 7.2 | 5.8 | 8.7 | 7.2 | 5.8 | 8.3 | 6.9 | 5.7 | 7.7 | 6.6 | 5.7 | 7.2 | 6.3 | 5.5 | 140 |
| 145 | | | | 8.7 | 7.1 | 5.7 | 8.5 | 7 | 5.7 | 8.1 | 6.8 | 5.7 | 7.6 | 6.5 | 5.6 | 7.1 | 6.2 | 5.5 | 145 |
| 150 | | | | 8.5 | 7 | 5.6 | 8.4 | 6.9 | 5.7 | 8 | 6.7 | 5.6 | 7.4 | 6.4 | 5.6 | 7 | 6.1 | 5.5 | 150 |
| 155 | | | | 8.3 | 6.9 | 5.6 | 8.2 | 6.8 | 5.6 | 7.8 | 6.6 | 5.6 | 7.3 | 6.3 | 5.6 | 6.9 | 6 | 5.4 | 155 |
| 160 | | | | 8.2 | 6.8 | 5.6 | 8 | 6.7 | 5.6 | 7.6 | 6.5 | 5.6 | 7.2 | 6.2 | 5.5 | 6.8 | 6 | 5.4 | 160 |
| 165 | | | | 8 | 6.7 | 5.6 | 7.8 | 6.6 | 5.5 | 7.5 | 6.4 | 5.5 | 7.1 | 6.1 | 5.5 | 6.7 | 5.9 | 5.4 | 165 |
| 170 | | | | 7.8 | 6.6 | 5.5 | 7.7 | 6.5 | 5.5 | 7.3 | 6.4 | 5.5 | 7 | 6.1 | 5.5 | 6.6 | 5.8 | 5.3 | 170 |
| 175 | | | | 7.7 | 6.4 | 5.5 | 7.5 | 6.5 | 5.5 | 7.2 | 6.3 | 5.4 | 6.9 | 6 | 5.4 | 6.5 | 5.8 | 5.3 | 175 |
| 180 | | | | 7.5 | 6.3 | 5.5 | 7.4 | 6.4 | 5.4 | 7.1 | 6.2 | 5.4 | 6.8 | 6 | 5.4 | 6.4 | 5.7 | 5.3 | 180 |
| 185 | | | | 7.4 | 6.2 | 5.4 | 7.3 | 6.3 | 5.4 | 7 | 6.2 | 5.4 | 6.7 | 6 | 5.4 | 6.3 | 5.6 | 5.3 | 185 |
| 190 | | | | 7.2 | 6.1 | 5.4 | 7.2 | 6.2 | 5.4 | 7 | 6.1 | 5.4 | 6.6 | 5.9 | 5.4 | 6.1 | 5.6 | 5.3 | 190 |
| 195 | | | | 7.1 | 6 | 5.4 | 7.1 | 6.1 | 5.4 | 6.9 | 6.1 | 5.4 | 6.6 | 5.9 | 5.4 | 5.9 | 5.5 | 5.3 | 195 |
| 200 | | | | 6.9 | 5.9 | 5.4 | 6.9 | 6 | 5.4 | 6.8 | 6 | 5.4 | 6.5 | 5.8 | 5.4 | 5.6 | 5.5 | 5.3 | 200 |
| 205 | | | | 6.8 | 5.8 | 5.4 | 6.8 | 6 | 5.4 | 6.7 | 6 | 5.4 | 6.3 | 5.8 | 5.4 | 5.3 | 5.4 | 5.3 | 205 |
| 210 | | | | 6.6 | 5.8 | 5.4 | 6.8 | 5.9 | 5.4 | 6.6 | 5.9 | 5.4 | 6.2 | 5.8 | 5.4 | 5 | 5.4 | 5.3 | 210 |
| 215 | | | | 6.6 | 5.7 | 5.4 | 6.6 | 5.9 | 5.4 | 6.3 | 5.9 | 5.4 | 5.9 | 5.8 | 5.4 | 4.7 | 5.3 | 5.3 | 215 |
| 220 | | | | 6.4 | 5.7 | 5.4 | 6.5 | 5.8 | 5.4 | 6 | 5.8 | 5.4 | 5.6 | 5.8 | 5.4 | 4.4 | 5.2 | 5.3 | 220 |
| 225 | | | | 6.3 | 5.7 | 5.4 | 6.3 | 5.8 | 5.4 | 5.8 | 5.8 | 5.4 | 5.3 | 5.7 | 5.4 | 4.2 | 5.1 | 5.3 | 225 |
| 230 | | | | 6.3 | 5.6 | | 6.1 | 5.7 | 5.4 | 5.6 | 5.7 | 5.4 | 5.1 | 5.7 | 5.4 | 3.9 | 4.8 | 5.3 | 230 |
| 235 | | | | 6.2 | 5.6 | | 6 | 5.7 | 5.4 | 5.4 | 5.6 | 5.4 | 4.7 | 5.4 | 5.4 | 3.6 | 4.4 | 5.1 | 235 |
| 240 | | | | 6.1 | 5.6 | | 5.7 | 5.6 | 5.4 | 5.2 | 5.4 | 5.4 | 4.4 | 5.1 | 5.3 | 3.4 | 4.1 | 4.8 | 240 |
| 245 | | | | 6 | | | 5.5 | 5.5 | | 5 | 5.2 | 5.3 | 4.1 | 4.8 | 5.1 | 3.1 | 3.8 | 4.4 | 245 |
| 250 | | | | | | | 5.3 | 5.4 | | 4.9 | 5 | 5.1 | 3.8 | 4.5 | 4.7 | 2.8 | 3.5 | 4.1 | 250 |
| 255 | | | | | | | 5.1 | 5.2 | | 4.6 | 4.8 | 4.9 | 3.4 | 4.1 | 4.3 | 2.5 | 3.2 | 3.7 | 255 |
| 260 | | | | | | | 4.9 | 5 | | 4.5 | 4.6 | | 3.1 | 3.8 | 3.8 | | 2.9 | 3.3 | 260 |
| 265 | | | | | | | | | | 4.3 | 4.4 | | 2.9 | 3.4 | 3.4 | | 2.6 | 2.8 | 265 |
| 270 | | | | | | | | | | 4.1 | 4.2 | | 2.6 | 3.1 | 3 | | | | 270 |
| 275 | | | | | | | | | | 3.9 | 4 | | 2.3 | 2.7 | 2.5 | | | | 275 |
| 280 | | | | | | | | | | 3.8 | | | | | 2.4 | | | | 280 |

TAB 131366 / 131407 / 131418

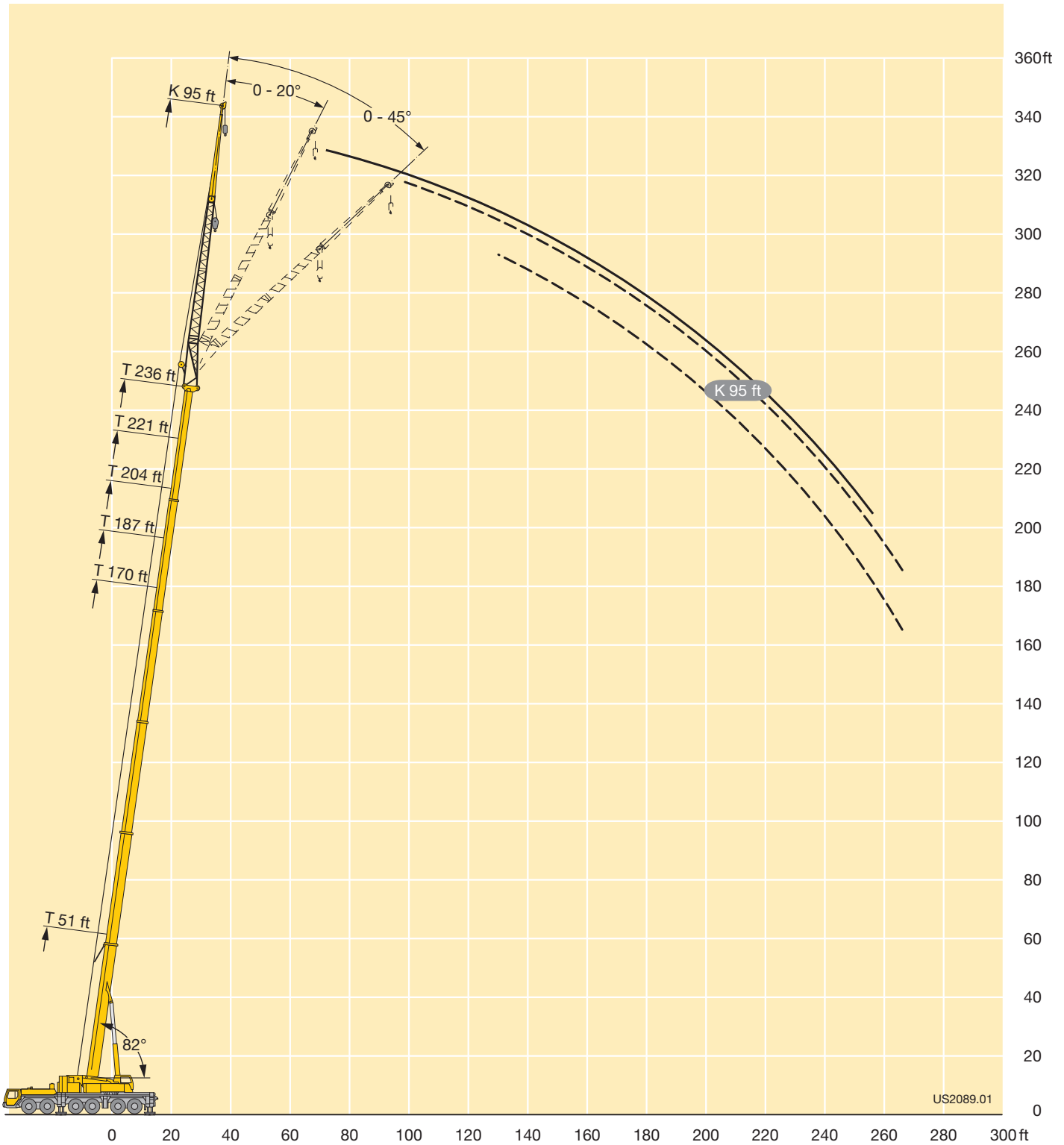

Lifting capacities Forces de levage

TNZK



| ft | 51 ft | | | 170 ft | | | 187 ft | | | 204 ft | | | 221 ft | | | 236 ft | | | ft | |
|-----|--------|-----|-----|--------|-----|-----|--------|-----|-----|--------|-----|-----|--------|-----|-----|--------|-----|-----|-----|-----|
| | 118 ft | | | 118 ft | | | 118 ft | | | 118 ft | | | 118 ft | | | 118 ft | | | | |
| | 0° | 20° | 45° | 0° | 20° | 45° | 0° | 20° | 45° | 0° | 20° | 45° | 0° | 20° | 45° | 0° | 20° | 45° | | |
| 18 | 8.7 | | | | | | | | | | | | | | | | | | 18 | |
| 20 | 8.7 | | | | | | | | | | | | | | | | | | 20 | |
| 22 | 8.7 | | | | | | | | | | | | | | | | | | 22 | |
| 24 | 8.7 | | | | | | | | | | | | | | | | | | 24 | |
| 26 | 8.7 | | | | | | | | | | | | | | | | | | 26 | |
| 28 | 8.7 | | | | | | | | | | | | | | | | | | 28 | |
| 30 | 8.7 | | | | | | | | | | | | | | | | | | 30 | |
| 32 | 8.7 | | | | | | | | | | | | | | | | | | 32 | |
| 34 | 8.7 | | | | | | | | | | | | | | | | | | 34 | |
| 36 | 8.7 | | | | | | | | | | | | | | | | | | 36 | |
| 38 | 8.7 | | | | | | | | | | | | | | | | | | 38 | |
| 40 | 8.7 | | | | | | | | | | | | | | | | | | 40 | |
| 45 | 8.4 | | | | | | | | | | | | | | | | | | 45 | |
| 50 | 8 | | | 8.5 | | | | | | | | | | | | | | | 50 | |
| 55 | 7.6 | 6.1 | | 8.5 | | | 7.8 | | | | | | | | | | | | 55 | |
| 60 | 7.2 | 6.1 | | 8.5 | | | 7.8 | | | | | | | | | | | | 60 | |
| 65 | 6.9 | 6.1 | | 8.5 | | | 7.8 | | | | | | | | | | | | 65 | |
| 70 | 6.5 | 5.9 | | 8.5 | | | 7.8 | | | 6.8 | | | 5.8 | | | | | | 70 | |
| 75 | 6.2 | 5.7 | | 8.4 | | | 7.8 | | | 6.8 | | | 5.8 | | | | 4.9 | | 75 | |
| 80 | 6 | 5.4 | | 8.3 | | | 7.8 | | | 6.8 | | | 5.8 | | | | 4.9 | | 80 | |
| 85 | 5.7 | 5.2 | | 8.1 | | | 7.8 | | | 6.8 | | | 5.8 | | | | 4.9 | | 85 | |
| 90 | 5.4 | 5 | | 7.9 | 5.8 | | 7.6 | | | 6.8 | | | 5.8 | | | | 4.9 | | 90 | |
| 95 | 5.2 | 4.7 | 3.9 | 7.7 | 5.8 | | 7.5 | 5.3 | | 6.8 | | | 5.8 | | | | 4.9 | | 95 | |
| 100 | 5 | 4.6 | 3.9 | 7.5 | 5.8 | | 7.2 | 5.3 | | 6.7 | 4.9 | | 5.8 | | | | 4.9 | | 100 | |
| 105 | 4.9 | 4.4 | 3.9 | 7.3 | 5.7 | | 7 | 5.3 | | 6.6 | 4.9 | | 5.8 | | | | 4.9 | | 105 | |
| 110 | 4.7 | 4.3 | 3.7 | 7.1 | 5.6 | | 6.9 | 5.3 | | 6.4 | 4.9 | | 5.7 | 4.6 | | | 4.9 | | 110 | |
| 115 | 4.6 | 4.2 | 3.6 | 6.9 | 5.4 | | 6.7 | 5.3 | | 6.2 | 4.9 | | 5.6 | 4.6 | | | 4.9 | 4.1 | 115 | |
| 120 | 4.5 | 4.1 | 3.5 | 6.7 | 5.3 | | 6.5 | 5.2 | | 6.1 | 4.9 | | 5.5 | 4.6 | | | 4.9 | 4.1 | 120 | |
| 125 | 4.3 | 3.9 | 3.4 | 6.5 | 5.2 | | 6.3 | 5.1 | | 5.9 | 4.9 | | 5.4 | 4.6 | | | 4.9 | 4.1 | 125 | |
| 130 | 4.2 | 3.9 | 3.4 | 6.4 | 5.1 | 3.9 | 6.1 | 5 | 3.9 | 5.8 | 4.8 | | 5.3 | 4.5 | | | 4.9 | 4.1 | 130 | |
| 135 | 4.1 | 3.8 | 3.4 | 6.2 | 4.9 | 3.9 | 6 | 4.9 | 3.9 | 5.7 | 4.7 | 3.6 | 5.2 | 4.4 | | | 4.9 | 4.1 | 135 | |
| 140 | 4 | 3.7 | 3.4 | 6 | 4.8 | 3.8 | 5.9 | 4.8 | 3.8 | 5.5 | 4.6 | 3.6 | 5.1 | 4.3 | 3.4 | | 4.8 | 4.1 | 140 | |
| 145 | 3.9 | 3.6 | 3.4 | 5.8 | 4.7 | 3.8 | 5.7 | 4.6 | 3.7 | 5.4 | 4.5 | 3.6 | 5.1 | 4.3 | 3.4 | | 4.7 | 4.1 | 145 | |
| 150 | 3.8 | 3.5 | 3.4 | 5.7 | 4.6 | 3.7 | 5.6 | 4.6 | 3.7 | 5.3 | 4.4 | 3.6 | 5 | 4.2 | 3.4 | | 4.6 | 4 | 3.2 | 150 |
| 155 | 3.7 | 3.4 | | 5.6 | 4.5 | 3.6 | 5.5 | 4.5 | 3.6 | 5.2 | 4.3 | 3.6 | 4.9 | 4.1 | 3.4 | | 4.5 | 3.9 | 3.2 | 155 |
| 160 | | | | 5.4 | 4.4 | 3.6 | 5.4 | 4.4 | 3.6 | 5.1 | 4.3 | 3.6 | 4.8 | 4.1 | 3.4 | | 4.4 | 3.9 | 3.2 | 160 |
| 165 | | | | 5.3 | 4.4 | 3.5 | 5.3 | 4.3 | 3.6 | 5 | 4.2 | 3.5 | 4.7 | 4 | 3.4 | | 4.4 | 3.8 | 3.2 | 165 |
| 170 | | | | 5.1 | 4.3 | 3.5 | 5.1 | 4.2 | 3.5 | 4.9 | 4.1 | 3.5 | 4.6 | 3.9 | 3.4 | | 4.4 | 3.7 | 3.2 | 170 |
| 175 | | | | 5 | 4.2 | 3.5 | 5 | 4.2 | 3.5 | 4.8 | 4.1 | 3.5 | 4.6 | 3.9 | 3.4 | | 4.3 | 3.7 | 3.2 | 175 |
| 180 | | | | 5 | 4.2 | 3.4 | 4.9 | 4.1 | 3.4 | 4.8 | 4 | 3.4 | 4.5 | 3.8 | 3.4 | | 4.2 | 3.7 | 3.2 | 180 |
| 185 | | | | 4.9 | 4.1 | 3.4 | 4.8 | 4.1 | 3.4 | 4.7 | 4 | 3.4 | 4.4 | 3.8 | 3.4 | | 4.2 | 3.6 | 3.2 | 185 |
| 190 | | | | 4.8 | 4.1 | 3.4 | 4.7 | 4 | 3.4 | 4.6 | 3.9 | 3.4 | 4.4 | 3.7 | 3.4 | | 4.1 | 3.6 | 3.2 | 190 |
| 195 | | | | 4.7 | 4 | 3.4 | 4.7 | 4 | 3.4 | 4.5 | 3.9 | 3.3 | 4.3 | 3.7 | 3.3 | | 4.1 | 3.5 | 3.2 | 195 |
| 200 | | | | 4.6 | 3.9 | 3.4 | 4.6 | 3.9 | 3.4 | 4.5 | 3.9 | 3.3 | 4.2 | 3.7 | 3.3 | | 4 | 3.5 | 3.2 | 200 |
| 205 | | | | 4.5 | 3.9 | 3.4 | 4.5 | 3.9 | 3.4 | 4.4 | 3.8 | 3.3 | 4.2 | 3.6 | 3.3 | | 4 | 3.5 | 3.2 | 205 |
| 210 | | | | 4.4 | 3.8 | 3.4 | 4.4 | 3.8 | 3.4 | 4.3 | 3.8 | 3.3 | 4.1 | 3.6 | 3.3 | | 3.9 | 3.4 | 3.2 | 210 |
| 215 | | | | 4.4 | 3.8 | 3.4 | 4.4 | 3.8 | 3.3 | 4.3 | 3.7 | 3.3 | 4.1 | 3.6 | 3.3 | | 3.8 | 3.4 | 3.2 | 215 |
| 220 | | | | 4.3 | 3.7 | 3.4 | 4.3 | 3.8 | 3.3 | 4.2 | 3.7 | 3.3 | 4.1 | 3.5 | 3.3 | | 3.6 | 3.4 | 3.2 | 220 |
| 225 | | | | 4.2 | 3.7 | 3.4 | 4.3 | 3.7 | 3.3 | 4.2 | 3.7 | 3.3 | 4 | 3.5 | 3.3 | | 3.4 | 3.3 | 3.2 | 225 |
| 230 | | | | 4.1 | 3.6 | 3.4 | 4.2 | 3.7 | 3.3 | 4.1 | 3.6 | 3.3 | 3.9 | 3.4 | 3.3 | | 3.2 | 3.3 | 3.2 | 230 |
| 235 | | | | 4.1 | 3.6 | 3.4 | 4.1 | 3.6 | 3.3 | 4.1 | 3.6 | 3.3 | 3.9 | 3.4 | 3.3 | | 2.9 | 3.2 | 3.2 | 235 |
| 240 | | | | 4 | 3.5 | 3.4 | 4.1 | 3.6 | 3.3 | 4 | 3.5 | 3.3 | 3.8 | 3.4 | 3.3 | | 2.7 | 3.2 | 3.2 | 240 |
| 245 | | | | 3.9 | 3.5 | 3.4 | 4 | 3.6 | 3.3 | 3.9 | 3.5 | 3.3 | 3.6 | 3.4 | 3.3 | | | 3.2 | 3.2 | 245 |
| 250 | | | | 3.9 | 3.4 | | 4 | 3.5 | 3.3 | 3.9 | 3.4 | 3.3 | 3.3 | 3.4 | 3.3 | | | 3.1 | 3.2 | 250 |
| 255 | | | | 3.8 | 3.4 | | 3.9 | 3.5 | 3.3 | 3.8 | 3.4 | 3.3 | 3 | 3.3 | 3.3 | | | 2.9 | 3.2 | 255 |
| 260 | | | | 3.8 | 3.4 | | 3.9 | 3.5 | 3.3 | 3.7 | 3.3 | 3.3 | 2.7 | 3.3 | 3.3 | | | 2.6 | 3.2 | 260 |
| 265 | | | | 3.7 | 3.4 | | 3.8 | 3.4 | 3.3 | 3.5 | 3.3 | 3.3 | 2.5 | 3.1 | 3.2 | | | | 3 | 265 |
| 270 | | | | | | | 3.7 | 3.4 | | 3.4 | 3.2 | 3.3 | | 2.9 | 3.2 | | | | 2.7 | 270 |
| 275 | | | | | | | 3.6 | 3.4 | | 3.2 | 3.2 | 3.3 | | 2.6 | 2.9 | | | | 2.3 | 275 |
| 280 | | | | | | | 3.6 | 3.4 | | 3 | 3.2 | 3 | | 2.3 | 2.5 | | | | | 280 |
| 285 | | | | | | | 3 | | | | 2.8 | 3.1 | | | | | | | | 285 |
| 290 | | | | | | | | | | | 2.6 | 2.9 | | | | | | | | 290 |
| 295 | | | | | | | | | | | 2.5 | 2.6 | | | | | | | | 295 |
| 300 | | | | | | | | | | | 2.3 | | | | | | | | | 300 |

TAB 131366 / 131407 / 131418

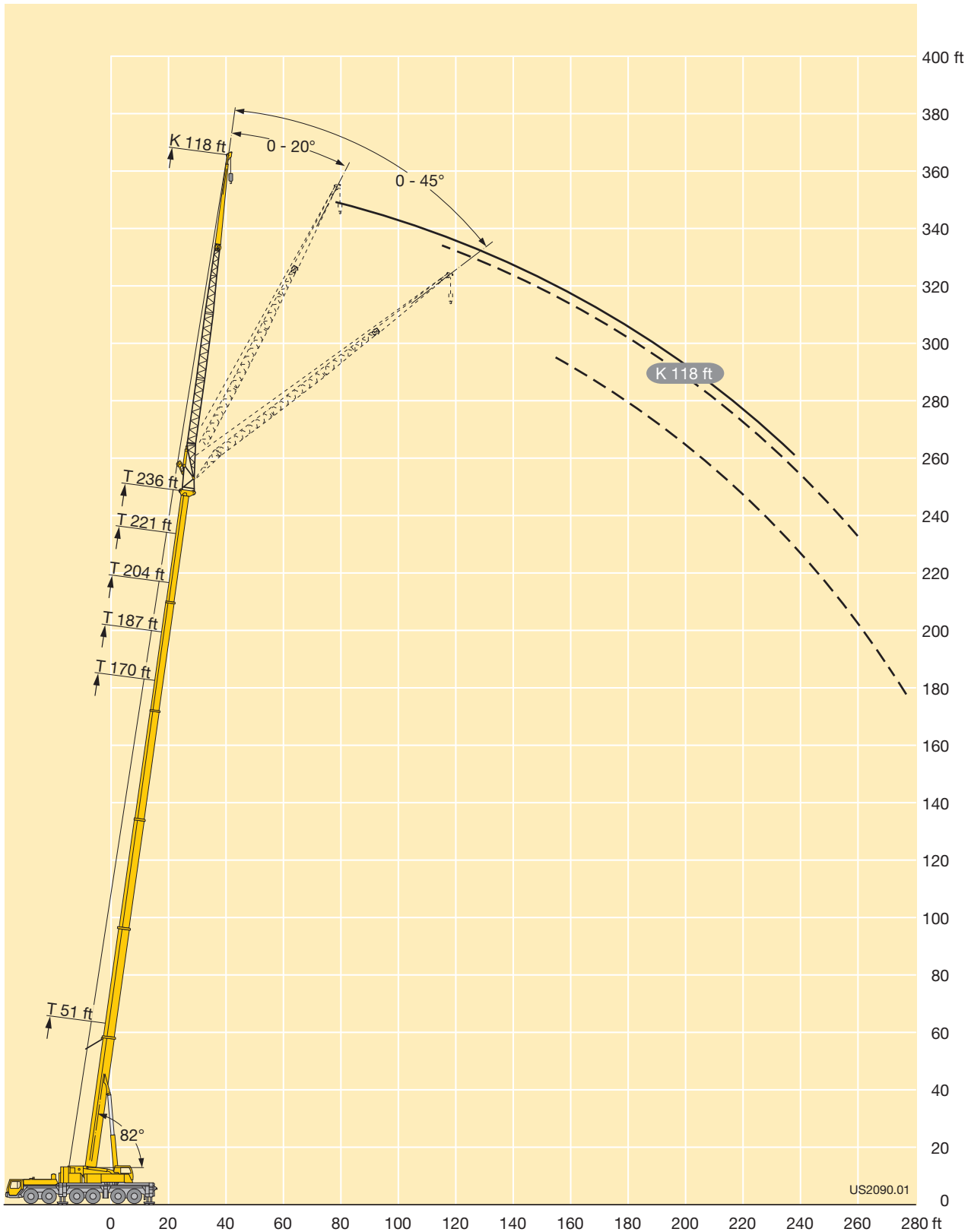

Lifting capacities Forces de levage

TF



| ft | 51 ft + 5 ft* | | | | | | | | | | | | | | | ft |
|-----|---------------|------|------|-------|------|------|-------|------|------|--------|-----|-----|--------|-----|-----|-----|
| | 46 ft | | | 69 ft | | | 92 ft | | | 115 ft | | | 138 ft | | | |
| | 0° | 20° | 40° | 0° | 20° | 40° | 0° | 20° | 40° | 0° | 20° | 40° | 0° | 20° | 40° | |
| 9 | 43.3 | | | | | | | | | | | | | | | 9 |
| 10 | 43.3 | | | | | | | | | | | | | | | 10 |
| 11 | 43.3 | | | | | | | | | | | | | | | 11 |
| 12 | 43.3 | | | | | | | | | | | | | | | 12 |
| 13 | 43.3 | | | 33 | | | | | | | | | | | | 13 |
| 14 | 43.3 | | | 32.9 | | | | | | | | | | | | 14 |
| 15 | 43.3 | | | 32.9 | | | | | | | | | | | | 15 |
| 16 | 43.1 | | | 32.7 | | | | | | | | | | | | 16 |
| 17 | 42.8 | | | 32.5 | | | | | | | | | | | | 17 |
| 18 | 42.5 | | | 32.3 | | | 24.4 | | | | | | | | | 18 |
| 20 | 41.9 | | | 31.8 | | | 24.3 | | | | | | | | | 20 |
| 22 | 41.1 | | | 31.2 | | | 23.8 | | | | | | | | | 22 |
| 24 | 40.1 | | | 30.6 | | | 23.3 | | | | | | | | | 24 |
| 26 | 39 | 39 | | 29.9 | | | 22.8 | | | | | | | | | 26 |
| 28 | 37.8 | 38 | | 29.2 | | | 22.2 | | | 16.7 | | | | | | 28 |
| 30 | 36.6 | 36.8 | | 28.6 | | | 21.7 | | | 16.6 | | | | | | 30 |
| 32 | 35 | 35.7 | | 27.9 | | | 21.1 | | | 16.2 | | | 12.3 | | | 32 |
| 34 | 33.6 | 34.6 | | 27.4 | | | 20.6 | | | 15.9 | | | 12.2 | | | 34 |
| 36 | 32.1 | 33.5 | | 26.8 | 24.2 | | 20.1 | | | 15.5 | | | 11.9 | | | 36 |
| 38 | 30.8 | 32.5 | 30.4 | 26.2 | 23.7 | | 19.7 | | | 15.2 | | | 11.6 | | | 38 |
| 40 | 29.4 | 31.6 | 30.2 | 25.7 | 23.2 | | 19.2 | | | 14.9 | | | 11.4 | | | 40 |
| 45 | 26.3 | 29.5 | 28.6 | 24.3 | 22 | | 18.2 | | | 14 | | | 10.8 | | | 45 |
| 50 | 23.3 | 27.6 | 27.1 | 22.9 | 21 | | 17.2 | 14.9 | | 13.3 | | | 10.2 | | | 50 |
| 55 | 20.6 | 25.1 | 25.6 | 21.4 | 20.1 | 17.6 | 16.3 | 14.6 | | 12.5 | | | 9.7 | | | 55 |
| 60 | 18.2 | 22.2 | 24.2 | 19.8 | 19.3 | 17.5 | 15.4 | 13.9 | | 11.8 | | | 9.1 | | | 60 |
| 65 | 16 | 19.4 | 22.5 | 18.1 | 18.6 | 17 | 14.7 | 13.2 | | 11.2 | 9.9 | | 8.6 | | | 65 |
| 70 | 14 | 16.9 | 19.6 | 16.3 | 18 | 16.6 | 14 | 12.6 | | 10.6 | 9.4 | | 8.1 | 7 | | 70 |
| 75 | 12.3 | 14.6 | 16.7 | 14.6 | 17.3 | 16.2 | 13.4 | 12.1 | 10.7 | 10 | 8.9 | | 7.7 | 6.8 | | 75 |
| 80 | 10.8 | 12.6 | 14.3 | 13 | 16.4 | 15.8 | 12.8 | 11.6 | 10.3 | 9.5 | 8.5 | | 7.2 | 6.4 | | 80 |
| 85 | 9.4 | 10.6 | 13.3 | 11.5 | 15.1 | 15.6 | 12.1 | 11.2 | 9.9 | 9 | 8.1 | | 6.8 | 6 | | 85 |
| 90 | 8.1 | 8.9 | | 10.4 | 13.4 | 15.2 | 11.5 | 10.8 | 9.6 | 8.6 | 7.7 | 6.5 | 6.4 | 5.7 | | 90 |
| 95 | | | | 9.3 | 11.8 | 13.9 | 10.7 | 10.4 | 9.3 | 8.3 | 7.3 | 6.3 | 6.1 | 5.4 | | 95 |
| 100 | | | | 8.3 | 10.3 | 12 | 9.8 | 10.1 | 9.1 | 7.9 | 7 | 6.1 | 5.8 | 5.2 | | 100 |
| 105 | | | | 7.3 | 8.8 | | 8.8 | 9.7 | 8.9 | 7.4 | 6.6 | 5.8 | 5.6 | 4.9 | | 105 |
| 110 | | | | 6.4 | 7.3 | | 8 | 9.4 | 8.8 | 7 | 6.4 | 5.7 | 5.4 | 4.7 | 4 | 110 |
| 115 | | | | | | | 7.2 | 9 | 8.8 | 6.6 | 6.2 | 5.5 | 5.2 | 4.5 | 3.9 | 115 |
| 120 | | | | | | | 6.5 | 8.3 | 8.7 | 6.3 | 6 | 5.4 | 4.9 | 4.3 | 3.8 | 120 |
| 125 | | | | | | | 5.8 | 7.2 | 8.6 | 6.1 | 5.8 | 5.3 | 4.7 | 4.1 | 3.6 | 125 |
| 130 | | | | | | | 5.1 | 6.1 | 8.5 | 5.8 | 5.6 | 5.2 | 4.4 | 4 | 3.5 | 130 |
| 135 | | | | | | | 4.4 | 5.1 | | 5.3 | 5.5 | 5.2 | 4.2 | 3.8 | 3.4 | 135 |
| 140 | | | | | | | | | | 4.7 | 5.5 | 5.2 | 4 | 3.7 | 3.3 | 140 |
| 145 | | | | | | | | | | 4.1 | 5.4 | 5.1 | 3.9 | 3.6 | 3.2 | 145 |
| 150 | | | | | | | | | | 3.6 | 4.8 | 5.1 | 3.8 | 3.4 | 3.1 | 150 |
| 155 | | | | | | | | | | 3 | 4 | | 3.5 | 3.4 | 3.1 | 155 |
| 160 | | | | | | | | | | | | | 3.1 | 3.3 | 3.1 | 160 |
| 165 | | | | | | | | | | | | | 2.7 | 3.3 | 3.1 | 165 |
| 170 | | | | | | | | | | | | | 2.5 | 3.3 | 3.1 | 170 |
| 175 | | | | | | | | | | | | | 2.4 | 2.8 | 3.1 | 175 |
| 180 | | | | | | | | | | | | | 2.4 | | | 180 |

* adapter - pièce d'adaptateur

TAB 131562 / 131572 / 131582

Lifting capacities Forces de levage

TF



| ft | 170 ft + 5 ft* | | | | | | | | | | | | | | | ft |
|-----|----------------|------|------|-------|------|------|-------|------|------|--------|-----|-----|--------|-----|-----|-----|
| | 46 ft | | | 69 ft | | | 92 ft | | | 115 ft | | | 138 ft | | | |
| | 0° | 20° | 40° | 0° | 20° | 40° | 0° | 20° | 40° | 0° | 20° | 40° | 0° | 20° | 40° | |
| 32 | 43.3 | | | | | | | | | | | | | | | 32 |
| 34 | 43.3 | | | | | | | | | | | | | | | 34 |
| 36 | 43.3 | | | | | | | | | | | | | | | 36 |
| 38 | 43.3 | | | 32.4 | | | | | | | | | | | | 38 |
| 40 | 43.3 | | | 32.3 | | | | | | | | | | | | 40 |
| 45 | 42.6 | | | 31.8 | | | 23.5 | | | | | | | | | 45 |
| 50 | 41.9 | 37.3 | | 31 | | | 23 | | | 16.8 | | | 12.6 | | | 50 |
| 55 | 41 | 36.6 | | 30.2 | | | 22.3 | | | 16.6 | | | 12.4 | | | 55 |
| 60 | 39.9 | 35.4 | | 29.3 | | | 21.5 | | | 16.1 | | | 12 | | | 60 |
| 65 | 38.6 | 34.1 | 29.6 | 28.4 | 22.8 | | 20.8 | | | 15.5 | | | 11.6 | | | 65 |
| 70 | 37.2 | 33 | 29.1 | 27.7 | 22.3 | | 20.1 | | | 15 | | | 11.2 | | | 70 |
| 75 | 35.6 | 32 | 28.5 | 27 | 21.7 | | 19.5 | 14.6 | | 14.6 | | | 10.9 | | | 75 |
| 80 | 33.9 | 31 | 27.8 | 26.2 | 21.2 | | 18.9 | 14.5 | | 14.1 | | | 10.5 | | | 80 |
| 85 | 32.2 | 30.1 | 27.1 | 25.5 | 20.8 | 17.5 | 18.3 | 14.2 | | 13.6 | | | 10.2 | | | 85 |
| 90 | 30.7 | 29.2 | 26.5 | 24.8 | 20.3 | 17.3 | 17.7 | 13.8 | | 13.2 | 9.7 | | 9.8 | | | 90 |
| 95 | 29.1 | 28.4 | 25.9 | 24.2 | 19.9 | 17 | 17.2 | 13.4 | 10.6 | 12.7 | 9.5 | | 9.5 | | | 95 |
| 100 | 27.7 | 27.7 | 25.4 | 23.5 | 19.6 | 16.8 | 16.7 | 13.1 | 10.5 | 12.3 | 9.3 | | 9.2 | 6.4 | | 100 |
| 105 | 26.3 | 26.9 | 24.9 | 22.8 | 19.2 | 16.6 | 16.2 | 12.8 | 10.3 | 11.9 | 9 | | 8.8 | 6.4 | | 105 |
| 110 | 24.9 | 25.5 | 24.4 | 22 | 18.8 | 16.5 | 15.8 | 12.5 | 10.2 | 11.5 | 8.7 | | 8.5 | 6.2 | | 110 |
| 115 | 23.5 | 24.2 | 24 | 21.2 | 18.5 | 16.3 | 15.3 | 12.3 | 10 | 11.1 | 8.5 | 6.3 | 8.2 | 6 | | 115 |
| 120 | 22.3 | 23 | 23.4 | 20.4 | 18.2 | 16.1 | 14.9 | 12 | 9.8 | 10.8 | 8.3 | 6.3 | 7.9 | 5.8 | | 120 |
| 125 | 21.1 | 21.8 | 22.4 | 19.6 | 17.9 | 15.9 | 14.5 | 11.8 | 9.7 | 10.5 | 8.1 | 6.1 | 7.7 | 5.6 | | 125 |
| 130 | 19.9 | 20.6 | 21.2 | 18.7 | 17.6 | 15.8 | 14.1 | 11.5 | 9.5 | 10.2 | 7.8 | 6 | 7.4 | 5.5 | | 130 |
| 135 | 18.8 | 19.5 | 20.1 | 17.8 | 17.3 | 15.7 | 13.7 | 11.3 | 9.4 | 9.8 | 7.6 | 5.9 | 7.1 | 5.3 | 3.9 | 135 |
| 140 | 17.8 | 18.4 | 19 | 16.8 | 17 | 15.6 | 13.4 | 11.1 | 9.3 | 9.5 | 7.4 | 5.8 | 6.9 | 5.1 | 3.9 | 140 |
| 145 | 16.8 | 17.4 | 17.9 | 15.9 | 16.6 | 15.5 | 13.1 | 10.9 | 9.1 | 9.2 | 7.2 | 5.7 | 6.6 | 5 | 3.8 | 145 |
| 150 | 15.8 | 16.3 | 16.9 | 15.1 | 16.1 | 15.4 | 12.8 | 10.7 | 9.1 | 9 | 7 | 5.6 | 6.4 | 4.9 | 3.7 | 150 |
| 155 | 14.8 | 15.4 | | 14.3 | 15.4 | 15.2 | 12.4 | 10.5 | 9 | 8.7 | 6.8 | 5.6 | 6.2 | 4.7 | 3.7 | 155 |
| 160 | 14 | 14.6 | | 13.5 | 14.6 | 14.9 | 12.1 | 10.3 | 8.9 | 8.5 | 6.7 | 5.5 | 6 | 4.6 | 3.6 | 160 |
| 165 | 13.2 | 13.7 | | 12.7 | 13.8 | 14.5 | 11.7 | 10.2 | 8.9 | 8.3 | 6.5 | 5.4 | 5.8 | 4.5 | 3.5 | 165 |
| 170 | 12.5 | 13 | | 11.9 | 13 | 13.7 | 11.4 | 10 | 8.8 | 8.1 | 6.4 | 5.4 | 5.7 | 4.4 | 3.5 | 170 |
| 175 | 11.8 | 12.2 | | 11.3 | 12.3 | 12.9 | 11 | 9.8 | 8.8 | 7.9 | 6.3 | 5.3 | 5.6 | 4.3 | 3.4 | 175 |
| 180 | 11.2 | 11.4 | | 10.7 | 11.6 | | 10.5 | 9.7 | 8.8 | 7.6 | 6.2 | 5.3 | 5.5 | 4.2 | 3.4 | 180 |
| 185 | 10.5 | 10.7 | | 10.1 | 10.9 | | 9.9 | 9.5 | 8.8 | 7.3 | 6 | 5.2 | 5.3 | 4.1 | 3.3 | 185 |
| 190 | 9.9 | 10 | | 9.6 | 10.3 | | 9.3 | 9.4 | 8.8 | 7.1 | 6 | 5.2 | 5.2 | 4 | 3.3 | 190 |
| 195 | 9.3 | | | 9.1 | 9.7 | | 8.8 | 9.3 | 8.8 | 6.8 | 5.8 | 5.2 | 5 | 3.9 | 3.2 | 195 |
| 200 | 8.7 | | | 8.6 | 9.1 | | 8.4 | 9.1 | | 6.6 | 5.7 | 5.2 | 4.9 | 3.8 | 3.2 | 200 |
| 205 | | | | 8.1 | 8.5 | | 8 | 8.7 | | 6.4 | 5.6 | 5.2 | 4.7 | 3.8 | 3.2 | 205 |
| 210 | | | | 7.6 | | | 7.5 | 8.1 | | 6.3 | 5.6 | 5.2 | 4.6 | 3.7 | 3.1 | 210 |
| 215 | | | | 7.1 | | | 7.1 | 7.6 | | 6.2 | 5.5 | 5.2 | 4.4 | 3.6 | 3.1 | 215 |
| 220 | | | | 6.7 | | | 6.7 | 7.2 | | 6 | 5.5 | 5.2 | 4.3 | 3.5 | 3.1 | 220 |
| 225 | | | | | | | 6.3 | 6.7 | | 5.9 | 5.5 | | 4.1 | 3.5 | 3.1 | 225 |
| 230 | | | | | | | 6 | 6.2 | | 5.6 | 5.5 | | 4.1 | 3.4 | 3.1 | 230 |
| 235 | | | | | | | 5.6 | 5.7 | | 5.3 | 5.4 | | 4 | 3.4 | 3.1 | 235 |
| 240 | | | | | | | 5.2 | | | 5 | 5.3 | | 3.9 | 3.4 | 3.1 | 240 |
| 245 | | | | | | | 4.9 | | | 4.6 | 5.1 | | 3.8 | 3.3 | | 245 |
| 250 | | | | | | | | | | 4.3 | 4.7 | | 3.7 | 3.3 | | 250 |
| 255 | | | | | | | | | | 4 | 4.4 | | 3.6 | 3.3 | | 255 |
| 260 | | | | | | | | | | 3.7 | | | 3.4 | 3.3 | | 260 |
| 265 | | | | | | | | | | 3.4 | | | 3.1 | 3.3 | | 265 |
| 270 | | | | | | | | | | | | | 2.8 | 3.2 | | 270 |
| 275 | | | | | | | | | | | | | 2.5 | 3 | | 275 |
| 280 | | | | | | | | | | | | | | 2.6 | | 280 |

* adapter · pièce d'adaptateur

TAB 131562 / 131572 / 131582

Lifting capacities Forces de levage

TF



| ft | 187 ft + 5 ft* | | | | | | | | | | | | | | | ft |
|-----|----------------|------|------|-------|------|------|-------|------|------|--------|-----|-----|--------|-----|-----|-----|
| | 46 ft | | | 69 ft | | | 92 ft | | | 115 ft | | | 138 ft | | | |
| | 0° | 20° | 40° | 0° | 20° | 40° | 0° | 20° | 40° | 0° | 20° | 40° | 0° | 20° | 40° | |
| 36 | 35.1 | | | | | | | | | | | | | | | 36 |
| 38 | 35.1 | | | | | | | | | | | | | | | 38 |
| 40 | 35.1 | | | | | | | | | | | | | | | 40 |
| 45 | 34.9 | | | 26.2 | | | 20.7 | | | | | | | | | 45 |
| 50 | 34.8 | | | 26.1 | | | 20.4 | | | 15.3 | | | | | | 50 |
| 55 | 34.4 | 33.1 | | 25.9 | | | 20 | | | 15.1 | | | 10.9 | | | 55 |
| 60 | 33.6 | 32.9 | | 25.5 | | | 19.3 | | | 14.7 | | | 10.9 | | | 60 |
| 65 | 32.6 | 32 | | 25.1 | | | 18.8 | | | 14.3 | | | 10.6 | | | 65 |
| 70 | 31.6 | 31.1 | 28 | 24.8 | 20.9 | | 18.3 | | | 13.9 | | | 10.3 | | | 70 |
| 75 | 30.5 | 30.2 | 27.6 | 24.5 | 20.7 | | 17.8 | | | 13.4 | | | 10 | | | 75 |
| 80 | 29.3 | 29.2 | 27 | 24.2 | 20.3 | | 17.4 | | | 13 | | | 9.7 | | | 80 |
| 85 | 27.9 | 28.2 | 26.4 | 23.8 | 19.9 | | 17 | 13.6 | | 12.6 | | | 9.4 | | | 85 |
| 90 | 26.6 | 27.1 | 25.9 | 23 | 19.5 | 16.8 | 16.6 | 13.3 | | 12.2 | | | 9.1 | | | 90 |
| 95 | 25.4 | 26.1 | 25.4 | 22.2 | 19.2 | 16.7 | 16.2 | 13 | | 11.9 | 9 | | 8.8 | | | 95 |
| 100 | 24.2 | 25.1 | 24.7 | 21.3 | 18.8 | 16.5 | 15.7 | 12.7 | 10.2 | 11.5 | 8.9 | | 8.5 | | | 100 |
| 105 | 23.1 | 24 | 23.9 | 20.5 | 18.5 | 16.3 | 15.3 | 12.4 | 10.2 | 11.2 | 8.6 | | 8.2 | | | 105 |
| 110 | 22 | 22.9 | 23.1 | 19.6 | 18.3 | 16.2 | 15 | 12.1 | 10 | 10.9 | 8.4 | | 8 | 5.9 | | 110 |
| 115 | 21 | 21.8 | 22.4 | 18.8 | 18 | 16 | 14.6 | 11.9 | 9.8 | 10.6 | 8.2 | | 7.7 | 5.8 | | 115 |
| 120 | 19.9 | 20.7 | 21.4 | 17.9 | 17.7 | 15.9 | 14.2 | 11.7 | 9.7 | 10.3 | 8 | 6 | 7.5 | 5.6 | | 120 |
| 125 | 18.9 | 19.6 | 20.3 | 17.2 | 17.5 | 15.8 | 13.9 | 11.4 | 9.5 | 10 | 7.8 | 6 | 7.2 | 5.5 | | 125 |
| 130 | 18 | 18.6 | 19.3 | 16.4 | 17.1 | 15.7 | 13.6 | 11.2 | 9.4 | 9.7 | 7.6 | 5.9 | 7 | 5.3 | | 130 |
| 135 | 17 | 17.6 | 18.2 | 15.7 | 16.5 | 15.6 | 13.3 | 11.1 | 9.3 | 9.4 | 7.4 | 5.9 | 6.8 | 5.2 | | 135 |
| 140 | 16.1 | 16.7 | 17.3 | 15 | 15.9 | 15.5 | 13 | 10.9 | 9.2 | 9.2 | 7.3 | 5.8 | 6.6 | 5 | 3.8 | 140 |
| 145 | 15.2 | 15.8 | 16.3 | 14.2 | 15.2 | 15.4 | 12.7 | 10.7 | 9.1 | 8.9 | 7.1 | 5.7 | 6.4 | 4.9 | 3.8 | 145 |
| 150 | 14.3 | 14.9 | 15.5 | 13.6 | 14.5 | 15 | 12.4 | 10.5 | 9 | 8.7 | 6.9 | 5.6 | 6.2 | 4.8 | 3.7 | 150 |
| 155 | 13.5 | 14 | 14.6 | 12.9 | 13.7 | 14.4 | 11.9 | 10.3 | 8.9 | 8.5 | 6.8 | 5.5 | 6 | 4.7 | 3.6 | 155 |
| 160 | 12.7 | 13.2 | 13.7 | 12.2 | 13 | 13.8 | 11.3 | 10.2 | 8.9 | 8.2 | 6.7 | 5.5 | 5.8 | 4.6 | 3.6 | 160 |
| 165 | 12.1 | 12.4 | | 11.5 | 12.3 | 13 | 10.8 | 10.1 | 8.8 | 8.1 | 6.5 | 5.4 | 5.7 | 4.4 | 3.5 | 165 |
| 170 | 11.5 | 11.8 | | 10.8 | 11.7 | 12.3 | 10.3 | 9.9 | 8.8 | 7.9 | 6.4 | 5.3 | 5.5 | 4.4 | 3.4 | 170 |
| 175 | 10.9 | 11.3 | | 10.2 | 11 | 11.7 | 9.7 | 9.8 | 8.7 | 7.8 | 6.2 | 5.3 | 5.4 | 4.2 | 3.4 | 175 |
| 180 | 10.3 | 10.7 | | 9.6 | 10.4 | 11 | 9.2 | 9.7 | 8.7 | 7.6 | 6.1 | 5.3 | 5.3 | 4.1 | 3.3 | 180 |
| 185 | 9.8 | 10.1 | | 9 | 9.8 | | 8.7 | 9.5 | 8.6 | 7.4 | 6 | 5.2 | 5.2 | 4.1 | 3.3 | 185 |
| 190 | 9.2 | 9.5 | | 8.6 | 9.2 | | 8.1 | 9.1 | 8.6 | 7.2 | 5.9 | 5.2 | 5.1 | 4 | 3.2 | 190 |
| 195 | 8.7 | 8.8 | | 8.3 | 8.6 | | 7.6 | 8.6 | 8.6 | 7 | 5.8 | 5.1 | 5 | 3.9 | 3.2 | 195 |
| 200 | 8.2 | 8.2 | | 7.9 | 8.2 | | 7.1 | 8.1 | 8.5 | 6.7 | 5.8 | 5.1 | 4.9 | 3.8 | 3.2 | 200 |
| 205 | 7.7 | | | 7.6 | 7.7 | | 6.7 | 7.6 | 8.2 | 6.3 | 5.7 | 5.1 | 4.8 | 3.8 | 3.1 | 205 |
| 210 | 7.2 | | | 7.1 | 7.3 | | 6.4 | 7.1 | | 5.9 | 5.6 | 5.1 | 4.6 | 3.7 | 3.1 | 210 |
| 215 | 6.7 | | | 6.7 | 6.9 | | 6.1 | 6.7 | | 5.5 | 5.5 | 5.1 | 4.5 | 3.6 | 3.1 | 215 |
| 220 | | | | 6.3 | 6.5 | | 5.9 | 6.3 | | 5.1 | 5.4 | 5.1 | 4.4 | 3.6 | 3.1 | 220 |
| 225 | | | | 5.9 | 6 | | 5.6 | 5.9 | | 4.8 | 5.4 | 5.1 | 4.2 | 3.5 | 3.1 | 225 |
| 230 | | | | 5.5 | | | 5.3 | 5.6 | | 4.6 | 5.3 | | 4 | 3.4 | 3.1 | 230 |
| 235 | | | | 5.1 | | | 5 | 5.3 | | 4.4 | 5 | | 3.6 | 3.4 | 3.1 | 235 |
| 240 | | | | 4.7 | | | 4.7 | 5 | | 4.2 | 4.6 | | 3.4 | 3.3 | 3.1 | 240 |
| 245 | | | | | | | 4.4 | 4.7 | | 3.9 | 4.3 | | 3.1 | 3.3 | 3.1 | 245 |
| 250 | | | | | | | 4 | | | 3.6 | 4.1 | | 2.9 | 3.3 | 3.1 | 250 |
| 255 | | | | | | | 3.7 | | | 3.2 | 3.8 | | 2.7 | 3.3 | 3.1 | 255 |
| 260 | | | | | | | 3.3 | | | 2.9 | 3.5 | | 2.5 | 3 | | 260 |
| 265 | | | | | | | | | | 2.6 | 3.1 | | | 2.8 | | 265 |
| 270 | | | | | | | | | | | 2.8 | | | 2.6 | | 270 |
| 275 | | | | | | | | | | | 2.4 | | | 2.3 | | 275 |

* adapter · pièce d'adaptateur

TAB 131562 / 131572 / 131582

Lifting capacities Forces de levage

TF



| ft | 204 ft + 5 ft* | | | | | | | | | | | | 221 ft + 5 ft* | | | | | | | | | | | | 236 ft + 5 ft* | | ft | | |
|-----|----------------|------|------|-------|------|------|-------|------|-----|--------|-----|-----|----------------|------|------|-------|------|------|-------|------|------|--------|-----|-----|----------------|-----|-----|-----|-----|
| | 46 ft | | | 69 ft | | | 92 ft | | | 115 ft | | | 46 ft | | | 69 ft | | | 92 ft | | | 115 ft | | | 115 ft | | | | |
| | 0° | 20° | 40° | 0° | 20° | 40° | 0° | 20° | 40° | 0° | 20° | 40° | 0° | 20° | 40° | 0° | 20° | 40° | 0° | 20° | 40° | 0° | 20° | 40° | 0° | 20° | | | |
| 45 | 28.1 | | | 20.9 | | | | | | | | | | 21.1 | | | | | | | | | | | | | | 45 | |
| 50 | 27.9 | | | 20.9 | | | 16.7 | | | | | | | 21.1 | | 16.6 | | | | | | | | | | | | 50 | |
| 55 | 27.8 | | | 20.9 | | | 16.7 | | | 12.7 | | | | 21.1 | | 16.6 | | | 12.9 | | | | | | | | | 55 | |
| 60 | 27.5 | | | 20.8 | | | 16.7 | | | 12.7 | | | | 21 | | 16.6 | | | 12.9 | | | | | | | | | 60 | |
| 65 | 26.9 | 25.8 | | 20.7 | | | 16.5 | | | 12.4 | | | | 20.9 | | 16.5 | | | 12.9 | | | 9 | | | | | | 65 | |
| 70 | 26.3 | 25.1 | | 20.6 | | | 16.2 | | | 12.1 | | | | 20.7 | 20.3 | 16.5 | | | 12.9 | | | 9 | | | | | | 70 | |
| 75 | 25.6 | 24.4 | 23.5 | 20.3 | 18.9 | | 15.8 | | | 11.8 | | | | 20.3 | 20 | 16.3 | | | 12.9 | | | 9 | | | | | | 75 | |
| 80 | 24.8 | 23.7 | 23.3 | 19.9 | 18.8 | | 15.5 | | | 11.5 | | | | 19.9 | 19.4 | 16 | | | 12.8 | | | 9 | | | | | | 80 | |
| 85 | 24.1 | 23 | 22.7 | 19.5 | 18.5 | | 15.2 | | | 11.2 | | | | 19.5 | 18.9 | 18.7 | 15.7 | 15.3 | 12.6 | | | 9 | | | | 6.6 | | 85 | |
| 90 | 23.2 | 22.3 | 22.1 | 19.1 | 18.1 | | 14.9 | 12.3 | | 10.9 | | | | 19.1 | 18.4 | 18.2 | 15.4 | 14.9 | 12.4 | | | 9 | | | | 6.6 | | 90 | |
| 95 | 22.2 | 21.5 | 21.4 | 18.6 | 17.7 | 16 | 14.7 | 12.2 | | 10.7 | | | | 18.5 | 17.9 | 17.8 | 15 | 14.5 | 12.1 | 11.1 | | 9 | | | | 6.6 | | 95 | |
| 100 | 21.2 | 20.7 | 20.6 | 17.9 | 17.2 | 15.9 | 14.4 | 11.9 | | 10.4 | 8.1 | | | 17.9 | 17.4 | 17.3 | 14.7 | 14.1 | 13.6 | 11.9 | 11 | | 9 | | | 6.6 | | 100 | |
| 105 | 20.3 | 20 | 19.9 | 17.3 | 16.8 | 15.8 | 14 | 11.7 | | 10.2 | 8.1 | | | 17.3 | 16.9 | 16.8 | 14.2 | 13.7 | 13.6 | 11.6 | 10.8 | | 8.9 | | | 6.6 | | 105 | |
| 110 | 19.4 | 19.3 | 19.2 | 16.7 | 16.3 | 15.7 | 13.7 | 11.5 | 9.7 | 9.9 | 7.9 | | | 16.7 | 16.4 | 16.4 | 13.8 | 13.3 | 13.2 | 11.3 | 10.7 | | 8.7 | 7.2 | | 6.6 | | 110 | |
| 115 | 18.5 | 18.6 | 18.6 | 16.1 | 15.9 | 15.4 | 13.5 | 11.3 | 9.6 | 9.7 | 7.7 | | | 16.2 | 15.9 | 15.9 | 13.4 | 12.9 | 12.9 | 10.9 | 10.5 | | 8.5 | 7.1 | | 6.6 | 6.5 | 115 | |
| 120 | 17.7 | 18 | 18 | 15.5 | 15.4 | 15.1 | 13.2 | 11.1 | 9.5 | 9.4 | 7.6 | | | 15.6 | 15.4 | 15.5 | 13 | 12.6 | 12.5 | 10.6 | 10.3 | 9.1 | 8.4 | 7 | | 6.6 | 6.5 | 120 | |
| 125 | 16.9 | 17.4 | 17.4 | 15 | 14.8 | 14.8 | 12.9 | 10.9 | 9.4 | 9.2 | 7.4 | | | 15 | 14.9 | 15 | 12.6 | 12.2 | 12.2 | 10.3 | 10 | 9.1 | 8.1 | 6.8 | | 6.6 | 6.3 | 125 | |
| 130 | 16.1 | 16.8 | 16.8 | 14.4 | 14.3 | 14.4 | 12.4 | 10.8 | 9.2 | 9 | 7.2 | 5.8 | | 14.5 | 14.4 | 14.5 | 12.3 | 11.9 | 11.9 | 10 | 9.7 | 9 | 7.9 | 6.7 | | 6.6 | 6.3 | 130 | |
| 135 | 15.3 | 16.1 | 16.3 | 13.8 | 13.9 | 13.9 | 12 | 10.6 | 9.2 | 8.8 | 7.1 | 5.7 | | 14 | 13.9 | 14 | 11.9 | 11.6 | 11.6 | 9.7 | 9.4 | 8.9 | 7.6 | 6.6 | | 6.5 | 6.2 | 135 | |
| 140 | 14.6 | 15.4 | 15.7 | 13.2 | 13.4 | 13.5 | 11.6 | 10.4 | 9.1 | 8.6 | 7 | 5.6 | | 13.4 | 13.4 | 13.6 | 11.5 | 11.2 | 11.3 | 9.4 | 9.1 | 8.8 | 7.4 | 6.5 | 5.4 | 6.4 | 6.1 | 140 | |
| 145 | 13.8 | 14.6 | 15.2 | 12.7 | 12.9 | 13 | 11.2 | 10.3 | 9 | 8.4 | 6.8 | 5.6 | | 12.8 | 13 | 13.1 | 11.1 | 10.9 | 11 | 9.1 | 8.9 | 8.8 | 7.2 | 6.3 | 5.4 | 6.2 | 6 | 145 | |
| 150 | 13.1 | 13.9 | 14.4 | 12 | 12.5 | 12.6 | 10.8 | 10.2 | 8.9 | 8.2 | 6.7 | 5.5 | | 12.2 | 12.5 | 12.7 | 10.7 | 10.6 | 10.7 | 8.9 | 8.6 | 8.7 | 6.9 | 6.3 | 5.3 | 6 | 5.9 | 150 | |
| 155 | 12.4 | 13.1 | 13.6 | 11.5 | 12.1 | 12.2 | 10.4 | 10 | 8.8 | 8 | 6.6 | 5.4 | | 11.6 | 12.1 | 12.3 | 10.3 | 10.3 | 10.4 | 8.6 | 8.4 | 8.5 | 6.7 | 6.2 | 5.3 | 5.8 | 5.8 | 155 | |
| 160 | 11.7 | 12.4 | 12.9 | 10.9 | 11.7 | 11.8 | 9.9 | 9.9 | 8.7 | 7.8 | 6.5 | 5.4 | | 11 | 11.6 | 11.9 | 9.9 | 9.9 | 10.2 | 8.3 | 8.1 | 8.3 | 6.5 | 6.1 | 5.2 | 5.5 | 5.7 | 160 | |
| 165 | 11 | 11.7 | 12.2 | 10.3 | 11.2 | 11.4 | 9.4 | 9.7 | 8.7 | 7.6 | 6.3 | 5.3 | | 10.5 | 11.1 | 11.5 | 9.4 | 9.6 | 9.8 | 8.1 | 7.9 | 8 | 6.3 | 6 | 5.2 | 5.3 | 5.5 | 165 | |
| 170 | 10.5 | 11.1 | 11.5 | 9.8 | 10.7 | 11.1 | 9 | 9.4 | 8.7 | 7.5 | 6.2 | 5.3 | | 9.9 | 10.5 | 10.9 | 9 | 9.3 | 9.5 | 7.8 | 7.7 | 7.8 | 6.1 | 6 | 5.1 | 5.1 | 5.3 | 170 | |
| 175 | 10 | 10.4 | 10.8 | 9.3 | 10.1 | 10.6 | 8.6 | 9.1 | 8.7 | 7.3 | 6.1 | 5.2 | | 9.4 | 9.9 | 10.3 | 8.5 | 8.9 | 9.1 | 7.5 | 7.5 | 7.6 | 5.9 | 5.9 | 5.1 | 4.8 | 5.2 | 175 | |
| 180 | 9.5 | 9.8 | | 8.7 | 9.5 | 10.1 | 8.1 | 8.8 | 8.6 | 7 | 6 | 5.2 | | 8.9 | 9.3 | 9.7 | 8.1 | 8.6 | 8.8 | 7.2 | 7.3 | 7.4 | 5.8 | 5.7 | 5.1 | 4.5 | 5.1 | 180 | |
| 185 | 9.1 | 9.4 | | 8.2 | 8.9 | 9.5 | 7.7 | 8.4 | 8.5 | 6.7 | 5.9 | 5.1 | | 8.4 | 8.8 | | 7.7 | 8.3 | 8.5 | 6.8 | 7.1 | 7.3 | 5.6 | 5.6 | 5 | 4.3 | 4.9 | 185 | |
| 190 | 8.7 | 8.9 | | 7.7 | 8.4 | 9 | 7.3 | 8.2 | 8.3 | 6.3 | 5.8 | 5.1 | | 7.8 | 8.3 | | 7.3 | 7.9 | 8.3 | 6.5 | 6.9 | 7.1 | 5.4 | 5.4 | 5 | 4 | 4.8 | 190 | |
| 195 | 8.3 | 8.5 | | 7.3 | 7.9 | 8.4 | 6.9 | 7.7 | 8.1 | 6 | 5.8 | 5.1 | | 7.3 | 7.9 | | 6.9 | 7.5 | 8 | 6.1 | 6.6 | 6.8 | 5.1 | 5.3 | 5 | 3.7 | 4.7 | 195 | |
| 200 | 8 | 8.1 | | 6.9 | 7.5 | | 6.5 | 7.3 | 7.8 | 5.6 | 5.7 | 5.1 | | 6.8 | 7.4 | | 6.5 | 7 | 7.5 | 5.8 | 6.4 | 6.6 | 4.8 | 5.1 | 5 | 3.4 | 4.5 | 200 | |
| 205 | 7.6 | 7.7 | | 6.6 | 7.1 | | 6.1 | 6.8 | 7.5 | 5.3 | 5.6 | 5.1 | | 6.4 | 7 | | 6 | 6.6 | 7.1 | 5.5 | 6.2 | 6.4 | 4.5 | 5 | 5 | 3.1 | 4.3 | 205 | |
| 210 | 7.2 | 7.3 | | 6.4 | 6.7 | | 5.7 | 6.4 | 7.1 | 4.9 | 5.6 | 5 | | 6.1 | 6.5 | | 5.6 | 6.1 | | 5.1 | 6 | 6.2 | 4.2 | 4.9 | 5 | | 4.1 | 210 | |
| 215 | 6.8 | 6.8 | | 6.1 | 6.4 | | 5.4 | 6 | 6.7 | 4.6 | 5.5 | 5 | | 5.7 | 6.1 | | 5.2 | 5.8 | | 4.8 | 5.7 | 6 | 3.9 | 4.7 | 4.9 | | 3.9 | 215 | |
| 220 | 6.3 | | | 5.8 | 6.1 | | 5.1 | 5.7 | 6.2 | 4.3 | 5.3 | 5 | | 5.3 | 5.7 | | 4.9 | 5.5 | | 4.5 | 5.3 | 5.8 | 3.7 | 4.6 | 4.8 | | 3.6 | 220 | |
| 225 | 5.9 | | | 5.6 | 5.8 | | 4.9 | 5.4 | | 4 | 5 | 5 | | 5 | 5.2 | | 4.5 | 5.1 | | 4.1 | 5 | 5.5 | 3.4 | 4.4 | 4.7 | | 3.3 | 225 | |
| 230 | 5.6 | | | 5.3 | 5.5 | | 4.7 | 5 | | 3.8 | 4.7 | 5 | | 4.6 | 4.8 | | 4.1 | 4.7 | | 3.8 | 4.6 | | 3.1 | 4.1 | 4.5 | | 3 | 230 | |
| 235 | 5.2 | | | 5 | 5.2 | | 4.5 | 4.8 | | 3.5 | 4.3 | 4.9 | | 4.2 | 4.4 | | 3.8 | 4.3 | | 3.4 | 4.3 | | 2.8 | 3.8 | 4.4 | | 2.7 | 235 | |
| 240 | | | | 4.7 | 4.8 | | 4.3 | 4.5 | | 3.3 | 3.9 | 4.6 | | 3.8 | | | 3.5 | 3.9 | | 3.1 | 3.9 | | 2.5 | 3.5 | 4.2 | | | 240 | |
| 245 | | | | 4.3 | | | 4 | 4.3 | | 3.1 | 3.6 | | | 3.5 | | | 3.1 | 3.5 | | 2.8 | 3.5 | | | 3.2 | 3.9 | | | 245 | |
| 250 | | | | 4 | | | 3.7 | 4.1 | | 2.9 | 3.4 | | | | | | 2.8 | 3.1 | | | 3.2 | | | 2.9 | 3.5 | | | 250 | |
| 255 | | | | 3.7 | | | 3.4 | 3.8 | | 2.6 | 3.1 | | | | | | 2.5 | 2.7 | | | 2.8 | | | 2.6 | 3.2 | | | 255 | |
| 260 | | | | | | | 3.1 | 3.5 | | 2.4 | 2.9 | | | | | | | | | | 2.4 | | | 2.2 | | | | | 260 |
| 265 | | | | | | | 2.8 | | | | 2.6 | | | | | | | | | | | | | | | | | | 265 |
| 270 | | | | | | | 2.5 | | | | 2.4 | | | | | | | | | | | | | | | | | | 270 |
| 275 | | | | | | | 2.2 | | | | 2.2 | | | | | | | | | | | | | | | | | | 275 |

* adapter · pièce d'adaptateur

TAB 131562 / 131572 / 131582

Lifting heights Hauteurs de levage

TF

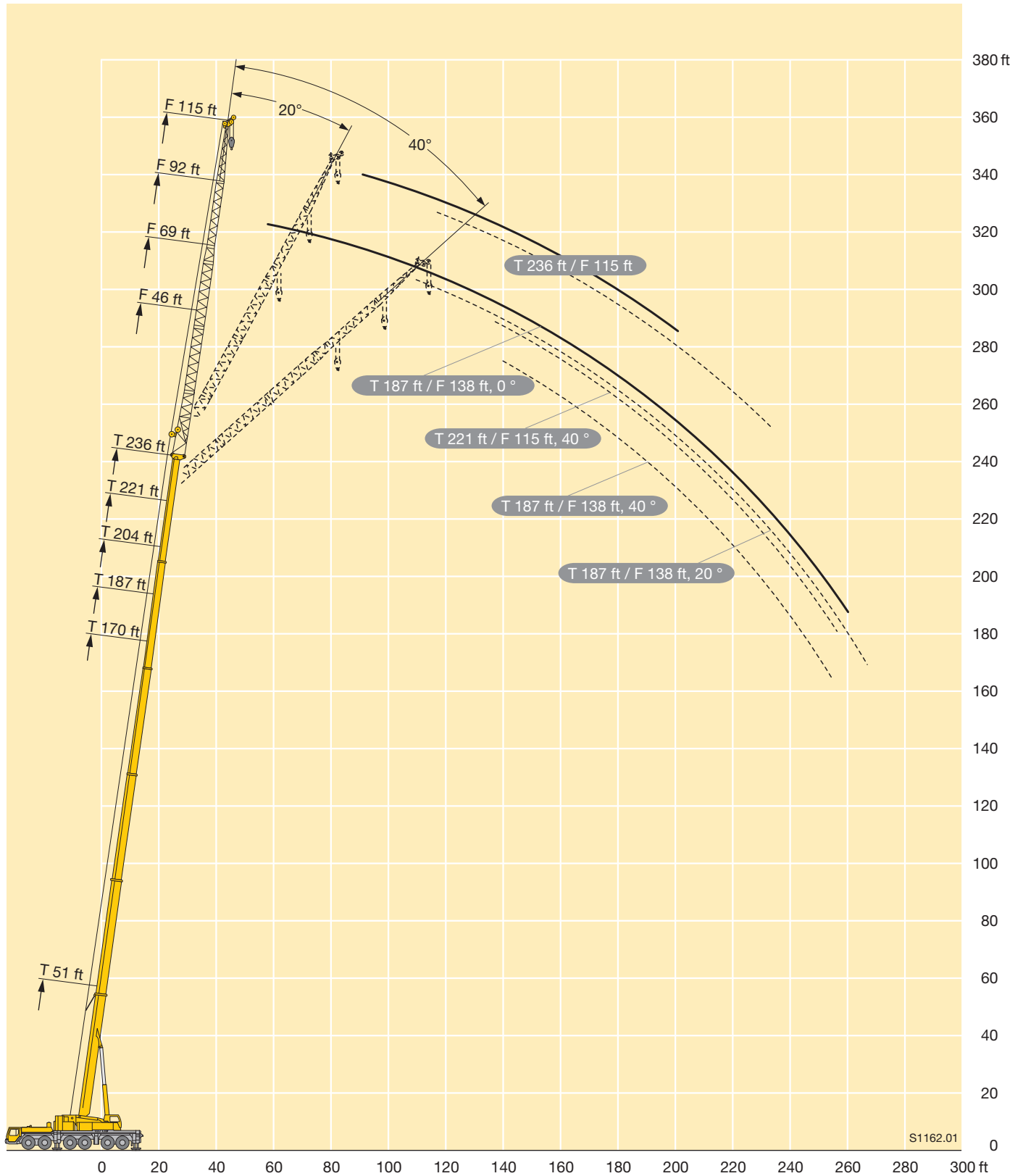

Lifting capacities Forces de levage

TN







| ft | 51 ft + 10 ft* | | | | | | | | 85 ft + 10 ft* | | | | | | | | 119 ft + 10 ft* | | | | | | | ft | | | | | |
|-----|----------------|-------|-------|--------|--------|--------|--------|--------|----------------|-------|-------|-------|--------|--------|--------|--------|-----------------|--------|-------|-------|-------|--------|--------|------|--------|--------|--------|-----|-----|
| | 57 ft | 69 ft | 92 ft | 115 ft | 138 ft | 161 ft | 184 ft | 207 ft | 230 ft | 57 ft | 69 ft | 92 ft | 115 ft | 138 ft | 161 ft | 184 ft | 207 ft | 230 ft | 57 ft | 69 ft | 92 ft | 115 ft | 138 ft | | 161 ft | 184 ft | 207 ft | | |
| 22 | 112 | | | | | | | | | | | | | | | | | | | | | | | | | | | 22 | |
| 24 | 112 | | | | | | | | | | | | | | | | | | | | | | | | | | | 24 | |
| 26 | 112 | 112 | | | | | | | | | | | | | | | | | | | | | | | | | | 26 | |
| 28 | 112 | 112 | | | | | | | | | | | | | | | | | | | | | | | | | | 28 | |
| 30 | 112 | 112 | | | | | | | 95.5 | | | | | | | | | | | | | | | | | | | 30 | |
| 32 | 112 | 112 | | | | | | | 95.5 | 85.5 | | | | | | | | | | | | | | | | | | 32 | |
| 34 | 112 | 111 | | | | | | | 95.5 | 85.5 | | | | | | | | | | | | | | | | | | 34 | |
| 36 | 111 | 109 | 86.5 | | | | | | 95.5 | 85.5 | | | | | | | | | 65 | | | | | | | | | 36 | |
| 38 | 111 | 108 | 85.5 | | | | | | 95.5 | 85.5 | | | | | | | | | 65 | 57.6 | | | | | | | | 38 | |
| 40 | 110 | 107 | 84.5 | | | | | | 95.5 | 85.5 | 67 | | | | | | | | 65 | 57.5 | | | | | | | | 40 | |
| 45 | 106 | 104 | 82.5 | 65.5 | | | | | 95.5 | 85.5 | 66.5 | | | | | | | | 65 | 57.3 | 44.7 | | | | | | | 45 | |
| 50 | 95.5 | 102 | 80.5 | 64.5 | 50.8 | | | | 95.5 | 85.5 | 66 | 51.1 | | | | | | | 65 | 57.2 | 44.6 | | | | | | | 50 | |
| 55 | 80.5 | 96.5 | 79 | 63.5 | 50.6 | 39.8 | | | 93 | 85.5 | 65.5 | 50.9 | 40.3 | | | | | | 65 | 57.1 | 44.4 | 35.6 | | | | | | 55 | |
| 60 | | 86 | 78 | 62 | 50 | 39.7 | | | | 85 | 65.5 | 50.6 | 40.3 | | | | | | 65 | 57.1 | 44.3 | 35.6 | | | | | | 60 | |
| 65 | | 72.5 | 77 | 61 | 49.3 | 39.3 | 31.1 | | | 84.5 | 65.5 | 50.3 | 40 | 31.8 | | | | | 65 | 57.1 | 44.2 | 35.4 | 28.5 | | | | | 65 | |
| 70 | | | 73.5 | 60.5 | 48.5 | 38.9 | 30.8 | 24.6 | | | 77.5 | 65 | 50.1 | 39.8 | 31.6 | 24.9 | | | | 57.1 | 44.1 | 35.3 | 28.4 | 22.6 | | | | 70 | |
| 75 | | | 67.5 | 59.6 | 47.8 | 38.5 | 30.4 | 24.4 | 18.2 | | | 65 | 50 | 39.5 | 31.3 | 24.8 | 20 | | | 57.1 | 44.1 | 35.1 | 28.2 | 22.5 | 18 | | | 75 | |
| 80 | | | 59 | 59 | 47.2 | 38.1 | 30.1 | 24.1 | 18 | | | 64.5 | 50 | 39.3 | 31.1 | 24.6 | 19.9 | | | | 44.1 | 35 | 28.1 | 22.4 | 18 | | | 80 | |
| 85 | | | 50.5 | 58.3 | 46.6 | 37.6 | 29.8 | 23.9 | 17.3 | | | 62.5 | 49.9 | 39.1 | 30.9 | 24.4 | 19.7 | 15.5 | | | 44.1 | 35 | 28 | 22.3 | 17.9 | 14.1 | | 85 | |
| 90 | | | 41.3 | 55.2 | 46.2 | 37.2 | 29.5 | 23.6 | 16.6 | | | 56.6 | 49.9 | 39.1 | 30.7 | 24.3 | 19.6 | 15.1 | | | 44.1 | 35 | 27.9 | 22.3 | 17.8 | 14 | | 90 | |
| 95 | | | | 50.7 | 45.3 | 36.8 | 29.3 | 23.4 | 16 | | | 46.3 | 49.8 | 39 | 30.5 | 24.1 | 19.4 | 14.6 | | | 44.1 | 35 | 27.9 | 22.2 | 17.7 | 14 | | 95 | |
| 100 | | | | 45.5 | 44.1 | 36.5 | 29 | 23.1 | 15.4 | | | | 49.5 | 39 | 30.5 | 23.9 | 19.2 | 14.1 | | | | 35 | 27.9 | 22.1 | 17.6 | 13.9 | | 100 | |
| 105 | | | | 40.3 | 42.7 | 36.1 | 28.8 | 22.8 | 14.8 | | | | 48.7 | 39 | 30.4 | 23.8 | 19.1 | 13.6 | | | | 35 | 27.9 | 22.1 | 17.5 | 13.8 | | 105 | |
| 110 | | | | 34.5 | 41.2 | 35.8 | 28.6 | 22.5 | 14.2 | | | | 45 | 38.7 | 30.3 | 23.7 | 18.9 | 13.2 | | | | 35 | 27.9 | 22.1 | 17.5 | 13.8 | | 110 | |
| 115 | | | | | 39 | 35.5 | 28.3 | 22 | 13.7 | | | | 40.3 | 38.2 | 30.3 | 23.6 | 18.8 | 12.8 | | | | 35 | 27.9 | 22.1 | 17.4 | 13.7 | | 115 | |
| 120 | | | | | 36 | 35.2 | 27.8 | 21.6 | 13.2 | | | | | 37.5 | 30.2 | 23.4 | 18.7 | 12.3 | | | | 35 | 27.9 | 22.1 | 17.4 | 13.7 | | 120 | |
| 125 | | | | | 32.4 | 34.7 | 27.3 | 21.2 | 12.6 | | | | | 36.5 | 30.2 | 23.2 | 18.6 | 11.9 | | | | | 27.9 | 22.1 | 17.4 | 13.6 | | 125 | |
| 130 | | | | | 28.6 | 33.7 | 26.7 | 20.7 | 12.1 | | | | | 34.7 | 30.1 | 22.8 | 18.5 | 11.5 | | | | | 27.9 | 22.1 | 17.4 | 13.6 | | 130 | |
| 135 | | | | | 23.6 | 31.5 | 26.2 | 20.2 | 11.6 | | | | | 31.8 | 30.1 | 22.5 | 18.4 | 11.1 | | | | | 27.9 | 22.1 | 17.4 | 13.6 | | 135 | |
| 140 | | | | | | 28.9 | 25.7 | 19.7 | 11.1 | | | | | 27.2 | 30.1 | 22.1 | 18.1 | 10.7 | | | | | 27.9 | 22.1 | 17.4 | 13.6 | | 140 | |
| 145 | | | | | | 26.2 | 25.3 | 19.3 | 10.6 | | | | | | 29.9 | 21.7 | 17.8 | 10.2 | | | | | | | 22.1 | 17.4 | 13.6 | | 145 |
| 150 | | | | | | 23.5 | 25 | 18.8 | 10.2 | | | | | | 28.5 | 21.4 | 17.5 | 9.8 | | | | | | | 22.1 | 17.4 | 13.6 | | 150 |
| 155 | | | | | | 20.6 | 24.3 | 18.4 | 9.7 | | | | | | 26.1 | 21.2 | 17.2 | 9.4 | | | | | | | 22.1 | 17.4 | 13.6 | | 155 |
| 160 | | | | | | | 23.1 | 18 | 9.3 | | | | | | 23.4 | 21 | 16.9 | 9.1 | | | | | | | 22.1 | 17.4 | 13.6 | | 160 |
| 165 | | | | | | | 21.3 | 17.6 | 8.9 | | | | | | | 20.8 | 16.6 | 8.7 | | | | | | | 22.1 | 17.4 | 13.6 | | 165 |
| 170 | | | | | | | 19.3 | 17.2 | 8.5 | | | | | | | 20.6 | 16.3 | 8.3 | | | | | | | 22.1 | 17.4 | 13.6 | | 170 |
| 175 | | | | | | | 17.3 | 16.9 | 8.1 | | | | | | | 20.5 | 16.1 | 8 | | | | | | | | 17.4 | 13.6 | | 175 |
| 180 | | | | | | | 14.5 | 16.6 | 7.7 | | | | | | | 19.8 | 15.8 | 7.7 | | | | | | | | 17.4 | 13.6 | | 180 |
| 185 | | | | | | | | 16.2 | 7.4 | | | | | | | | 15.6 | 7.3 | | | | | | | | 17.4 | 13.6 | | 185 |
| 190 | | | | | | | | 15.9 | 7.1 | | | | | | | | 15.4 | 7 | | | | | | | | 17.4 | 13.6 | | 190 |
| 195 | | | | | | | | 14.6 | 6.8 | | | | | | | | 15.1 | 6.7 | | | | | | | | | 13.6 | | 195 |
| 200 | | | | | | | | 12.8 | 6.5 | | | | | | | | 14.9 | 6.5 | | | | | | | | | 13.5 | | 200 |
| 205 | | | | | | | | | 6.2 | | | | | | | | 14.3 | 6.2 | | | | | | | | | 13.4 | | 205 |
| 210 | | | | | | | | | 5.9 | | | | | | | | | 6 | | | | | | | | | 13.3 | | 210 |
| 215 | | | | | | | | | 5.7 | | | | | | | | | | 5.7 | | | | | | | | 13 | | 215 |
| 220 | | | | | | | | | 5.4 | | | | | | | | | | 5.5 | | | | | | | | | | 220 |
| 225 | | | | | | | | | 5.3 | | | | | | | | | | 5.3 | | | | | | | | | | 225 |

* adapter · pièce d'adaptateur

TAB 131218

Lifting capacities Forces de levage

TN



| ft | 153 ft + 10 ft* | | | | | | | 187 ft + 10 ft* | | | | | 204 ft + 10 ft* | | | | 221 ft + 10 ft* | | | ft | |
|-----|-----------------|-------|-------|--------|--------|--------|--------|-----------------|-------|-------|--------|--------|-----------------|-------|-------|--------|-----------------|-------|-------|----|-----|
| | 57 ft | 69 ft | 92 ft | 115 ft | 138 ft | 161 ft | 184 ft | 57 ft | 69 ft | 92 ft | 115 ft | 138 ft | 57 ft | 69 ft | 92 ft | 115 ft | 57 ft | 69 ft | 92 ft | | |
| 45 | 40.3 | 35.6 | | | | | | | | | | | | | | | | | | | 45 |
| 50 | 40.2 | 35.5 | 27.8 | | | | | 24.1 | 21.3 | | | | | 18.1 | | | | | | | 50 |
| 55 | 40.1 | 35.4 | 27.7 | | | | | 24 | 21.2 | | | | 18 | 15.6 | | | 13.1 | | | | 55 |
| 60 | 40.1 | 35.3 | 27.6 | | | | | 23.9 | 21.1 | | | | 17.9 | 15.6 | | | 13 | | | | 60 |
| 65 | 40.1 | 35.2 | 27.5 | 21.5 | | | | 23.9 | 21 | 16.2 | | | 17.8 | 15.5 | 11.6 | | 13 | 11.1 | | | 65 |
| 70 | 40.1 | 35.2 | 27.4 | 21.4 | 17.2 | | | 23.9 | 20.9 | 16.1 | 12.3 | | 17.8 | 15.4 | 11.5 | 7.5 | 12.9 | 11 | 6.8 | | 70 |
| 75 | | 35.2 | 27.3 | 21.3 | 17.1 | 13.2 | | 23.9 | 20.9 | 16.1 | 12.2 | 8.5 | 17.8 | 15.4 | 11.5 | 7.5 | 12.9 | 11 | 6.8 | | 75 |
| 80 | | 35.2 | 27.3 | 21.2 | 17 | 13.2 | | | 20.9 | 16 | 12.2 | 8.5 | | 15.4 | 11.4 | 7.5 | | 10.9 | 6.8 | | 80 |
| 85 | | 35.2 | 27.3 | 21.2 | 16.9 | 13.1 | 9.5 | | 20.9 | 16 | 12.1 | 8.5 | | 15.4 | 11.3 | 7.5 | | 10.9 | 6.8 | | 85 |
| 90 | | | 27.3 | 21.1 | 16.9 | 13.1 | 9.5 | | | 16 | 12 | 8.5 | | 15.4 | 11.3 | 7.5 | | 10.9 | 6.8 | | 90 |
| 95 | | | 27.3 | 21.1 | 16.8 | 13 | 9.5 | | | 16 | 12 | 8.5 | | | 11.3 | 7.5 | | | 6.8 | | 95 |
| 100 | | | 27.3 | 21.1 | 16.8 | 12.9 | 9.5 | | | 15.9 | 12 | 8.5 | | | 11.2 | 7.5 | | | 6.8 | | 100 |
| 105 | | | | 21.1 | 16.8 | 12.9 | 9.5 | | | 15.9 | 12 | 8.5 | | | 11.2 | 7.5 | | | 6.8 | | 105 |
| 110 | | | | 21.1 | 16.8 | 12.8 | 9.5 | | | 15.9 | 12 | 8.5 | | | 11.2 | 7.5 | | | 6.8 | | 110 |
| 115 | | | | 21.1 | 16.8 | 12.8 | 9.5 | | | | 12 | 8.5 | | | | 7.5 | | | | | 115 |
| 120 | | | | 21.1 | 16.8 | 12.8 | 9.5 | | | | 12 | 8.5 | | | | 7.5 | | | | | 120 |
| 125 | | | | 21.1 | 16.8 | 12.8 | 9.5 | | | | 12 | 8.5 | | | | 7.5 | | | | | 125 |
| 130 | | | | 21.1 | 16.8 | 12.8 | 9.5 | | | | 12 | 8.5 | | | | 7.5 | | | | | 130 |
| 135 | | | | | 16.8 | 12.8 | 9.5 | | | | | 8.5 | | | | 7.5 | | | | | 135 |
| 140 | | | | | 16.8 | 12.8 | 9.5 | | | | | 8.5 | | | | | | | | | 140 |
| 145 | | | | | 16.8 | 12.8 | 9.5 | | | | | 8.5 | | | | | | | | | 145 |
| 150 | | | | | 16.8 | 12.8 | 9.5 | | | | | 8.5 | | | | | | | | | 150 |
| 155 | | | | | | 12.8 | 9.5 | | | | | 8.5 | | | | | | | | | 155 |
| 160 | | | | | | 12.8 | 9.5 | | | | | | | | | | | | | | 160 |
| 165 | | | | | | 12.8 | 9.5 | | | | | | | | | | | | | | 165 |
| 170 | | | | | | 12.8 | 9.5 | | | | | | | | | | | | | | 170 |
| 175 | | | | | | | 9.5 | | | | | | | | | | | | | | 175 |
| 180 | | | | | | | 9.5 | | | | | | | | | | | | | | 180 |
| 185 | | | | | | | | 9.5 | | | | | | | | | | | | | 185 |
| 190 | | | | | | | | 9.5 | | | | | | | | | | | | | 190 |
| 195 | | | | | | | | 9.5 | | | | | | | | | | | | | 195 |

* adapter · pièce d'adaptateur

TAB 131218

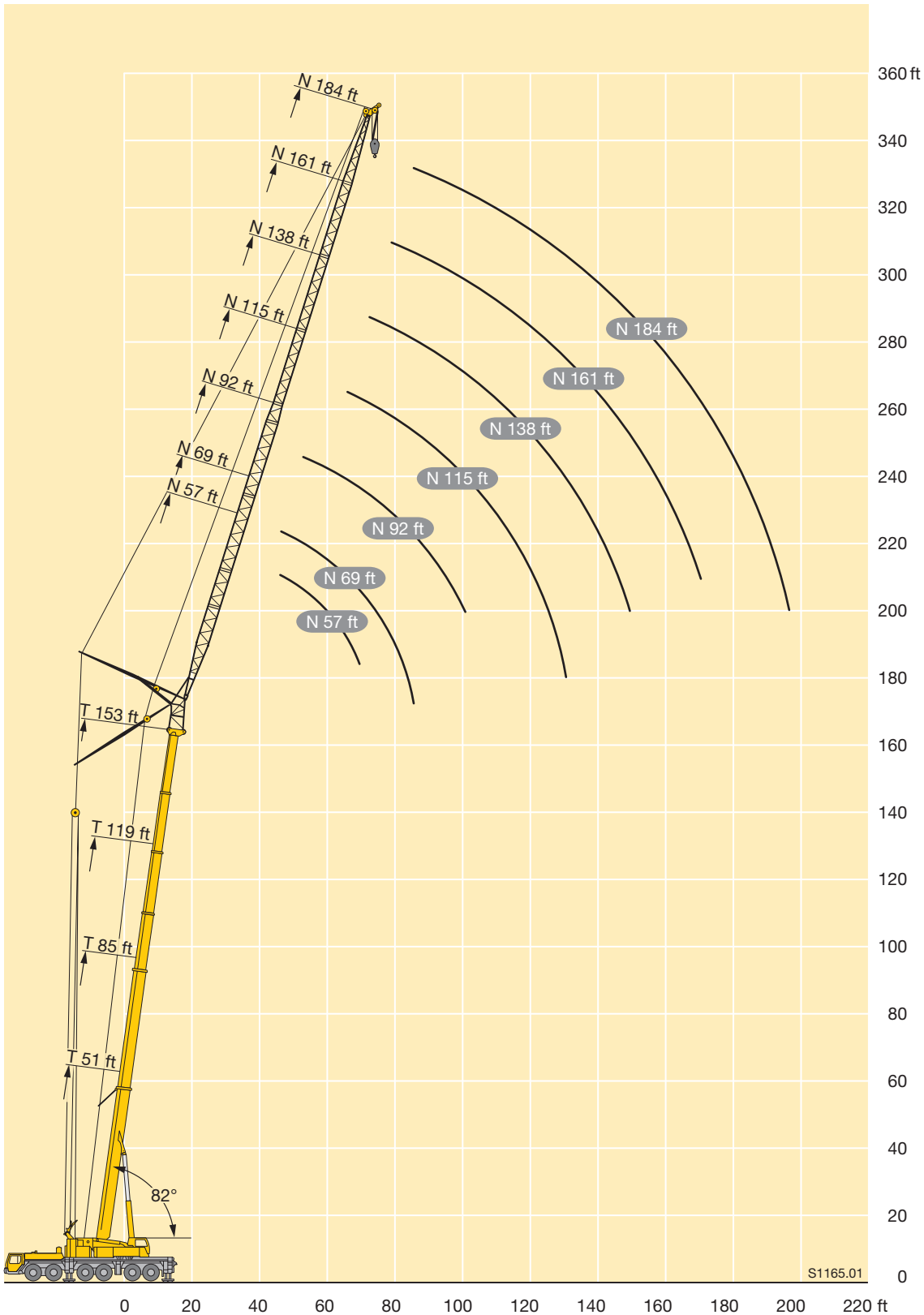

Lifting capacities Forces de levage

TN

| ft | 51 - 119 ft | | 57 - 230 ft | | 360° | | 159800 lbs | | 85% | | ft | | | | | | | | | | | | | | | | | |
|-----|----------------|-------|-------------|--------|--------|--------|------------|--------|----------------|-------|------|-------|-------|--------|--------|--------|-----------------|--------|--------|-------|-------|-------|--------|--------|--------|--------|--------|-----|
| | 51 ft + 10 ft* | | | | | | | | 85 ft + 10 ft* | | | | | | | | 119 ft + 10 ft* | | | | | | | | | | | |
| | 57 ft | 69 ft | 92 ft | 115 ft | 138 ft | 161 ft | 184 ft | 207 ft | 230 ft | 57 ft | | 69 ft | 92 ft | 115 ft | 138 ft | 161 ft | 184 ft | 207 ft | 230 ft | 57 ft | 69 ft | 92 ft | 115 ft | 138 ft | 161 ft | 184 ft | 207 ft | |
| 38 | 112 | | | | | | | | | | | | | | | | | | | | | | | | | 38 | | |
| 40 | 112 | | | | | | | | | | | | | | | | | | | | | | | | | | 40 | |
| 45 | 109 | 102 | | | | | | | | | | | | | | | | | | | | | | | | | 45 | |
| 50 | 106 | 98.5 | | | | | | | 92.5 | | | | | | | | | | | | | | | | | | 50 | |
| 55 | 99 | 95 | 78 | | | | | | 92 | 83 | | | | | | | | | | | | | | | | | 55 | |
| 60 | 89.5 | 91.5 | 76 | | | | | | 90.5 | 82.5 | | | | | | | | | 63 | | | | | | | | 60 | |
| 65 | 79 | 88.5 | 74 | 60 | | | | | 86.5 | 81.5 | 63.5 | | | | | | | | 63 | 55.9 | | | | | | | 65 | |
| 70 | | 81.5 | 73 | 59.1 | 48 | | | | 83 | 79.5 | 63 | 49.3 | | | | | | | 60.5 | 55.9 | | | | | | | 70 | |
| 75 | | | 72 | 57.9 | 47.5 | | | | 76 | 62.5 | 49.2 | | | | | | | | 58.3 | 55.2 | 43.4 | | | | | | 75 | |
| 80 | | | 70.5 | 56.8 | 46.6 | | | | 72 | 62 | 49 | | | | | | | | 53.8 | 43.4 | | | | | | | 80 | |
| 85 | | | 66.5 | 56.1 | 45.7 | 37.4 | | | 68 | 62 | 48.7 | 38.6 | | | | | | | 51.7 | 43.3 | 34.5 | | | | | | 85 | |
| 90 | | | 58.7 | 55.6 | 44.9 | 36.8 | 29.3 | | | 60.5 | 48.4 | 38.4 | 30.3 | | | | | | 49.8 | 43.2 | 34.4 | | | | | | 90 | |
| 95 | | | 49.7 | 55.1 | 44.3 | 36.2 | 29.1 | | | 57.9 | 48.1 | 38.2 | 30.1 | | | | | | | 43.1 | 34.3 | 27.4 | | | | | 95 | |
| 100 | | | | 53.9 | 43.8 | 35.7 | 28.8 | 22.8 | | 55 | 48 | 38 | 30 | 23.5 | | | | | | 42.7 | 34.3 | 27.4 | 21.8 | | | | 100 | |
| 105 | | | | 50.9 | 43.4 | 35.1 | 28.5 | 22.8 | | | 48 | 37.9 | 29.8 | 23.5 | | | | | | 41.5 | 34.2 | 27.3 | 21.8 | | | | 105 | |
| 110 | | | | 45.9 | 42.8 | 34.8 | 28.1 | 22.6 | 14.9 | | 47.4 | 37.8 | 29.7 | 23.4 | 18.7 | | | | | 40.4 | 34.2 | 27.3 | 21.7 | | | | 110 | |
| 115 | | | | 40.5 | 41.7 | 34.5 | 27.7 | 22.3 | 14.5 | | 45.8 | 37.8 | 29.6 | 23.2 | 18.7 | | | | | 39.6 | 34.2 | 27.2 | 21.7 | 17.2 | | | 115 | |
| 120 | | | | | 40.4 | 34.3 | 27.4 | 21.9 | 13.9 | | 43.8 | 37.8 | 29.5 | 23.1 | 18.6 | 12.9 | | | | | 34.1 | 27.2 | 21.6 | 17.2 | 13.1 | | 120 | |
| 125 | | | | | 38.9 | 34.2 | 27.1 | 21.5 | 13.3 | | 41.9 | 37.7 | 29.4 | 22.9 | 18.5 | 12.8 | | | | | 33.8 | 27.2 | 21.5 | 17.2 | 13.1 | | 125 | |
| 130 | | | | | 36.7 | 34 | 27 | 21 | 12.8 | | 38.3 | 37.2 | 29.4 | 22.8 | 18.4 | 12.4 | | | | | 33 | 27.2 | 21.5 | 17.1 | 13.1 | | 130 | |
| 135 | | | | | 33.4 | 33.9 | 26.8 | 20.6 | 12.3 | | | | | | | | | | | | | 32.5 | 27.2 | 21.4 | 17.1 | 13.1 | | 135 |
| 140 | | | | | 29.5 | 33.5 | 26.4 | 20.2 | 11.8 | | | | | | | | | | | | | | 27.2 | 21.4 | 17.1 | 13.1 | | 140 |
| 145 | | | | | 32.4 | 26 | 19.8 | 11.3 | | | | | | | | | | | | | | | 27.2 | 21.4 | 17 | 13.1 | | 145 |
| 150 | | | | | 30.1 | 25.6 | 19.3 | 10.8 | | | | | | | | | | | | | | | 27.2 | 21.4 | 17 | 13.1 | | 150 |
| 155 | | | | | 27.4 | 25.2 | 18.9 | 10.4 | | | | | | | | | | | | | | | 26.7 | 21.4 | 17 | 13.1 | | 155 |
| 160 | | | | | 24.6 | 24.8 | 18.5 | 9.9 | | | | | | | | | | | | | | | 26.1 | 21.4 | 17 | 13.1 | | 160 |
| 165 | | | | | | 24.4 | 18.1 | 9.5 | | | | | | | | | | | | | | | | 21.4 | 17 | 13.1 | | 165 |
| 170 | | | | | | 23.9 | 17.7 | 9.1 | | | | | | | | | | | | | | | | 21.4 | 17 | 13.1 | | 170 |
| 175 | | | | | | 22.3 | 17.3 | 8.7 | | | | | | | | | | | | | | | | 21.4 | 17 | 13.1 | | 175 |
| 180 | | | | | | 20.4 | 16.9 | 8.3 | | | | | | | | | | | | | | | | 21.4 | 17 | 13.1 | | 180 |
| 185 | | | | | | 18.2 | 16.6 | 7.9 | | | | | | | | | | | | | | | | | 17 | 13.1 | | 185 |
| 190 | | | | | | 15.6 | 16.3 | 7.5 | | | | | | | | | | | | | | | | | 17 | 13.1 | | 190 |
| 195 | | | | | | | 16 | 7.1 | | | | | | | | | | | | | | | | | 17 | 13.1 | | 195 |
| 200 | | | | | | | 15.8 | 6.8 | | | | | | | | | | | | | | | | | 17 | 13.1 | | 200 |
| 205 | | | | | | | | 15.2 | 6.4 | | | | | | | | | | | | | | | | 17 | 13.1 | | 205 |
| 210 | | | | | | | | | 6.2 | | | | | | | | | | | | | | | | | 13.1 | | 210 |
| 215 | | | | | | | | | 5.9 | | | | | | | | | | | | | | | | | 13.1 | | 215 |
| 220 | | | | | | | | | 5.7 | | | | | | | | | | | | | | | | | 13.1 | | 220 |
| 225 | | | | | | | | | 5.5 | | | | | | | | | | | | | | | | | 13.1 | | 225 |
| 230 | | | | | | | | | 5.3 | | | | | | | | | | | | | | | | | | | 230 |
| 235 | | | | | | | | | 5.2 | | | | | | | | | | | | | | | | | | | 235 |
| 240 | | | | | | | | | | | | | | | | | | | | | | | | | | | | 240 |

* adapter - pièce d'adaptateur

TAB 131221

Lifting capacities Forces de levage

TN



| ft | 153 ft + 10 ft* | | | | | | | 187 ft + 10 ft* | | | | | 204 ft + 10 ft* | | | | 221 ft + 10 ft* | | | ft | |
|-----|-----------------|-------|-------|--------|--------|--------|--------|-----------------|-------|-------|--------|--------|-----------------|-------|-------|--------|-----------------|-------|-------|-----|-----|
| | 57 ft | 69 ft | 92 ft | 115 ft | 138 ft | 161 ft | 184 ft | 57 ft | 69 ft | 92 ft | 115 ft | 138 ft | 57 ft | 69 ft | 92 ft | 115 ft | 57 ft | 69 ft | 92 ft | | |
| 70 | 39.3 | | | | | | | | | | | | | | | | | | | | 70 |
| 75 | 39.1 | 34.4 | | | | | | | | | | | | | | | | | | | 75 |
| 80 | 38.8 | 34.4 | | | | | | | | | | | | | | | | | | | 80 |
| 85 | 38.1 | 34.4 | | | | | | | | | | | | | | | | | | | 85 |
| 90 | 37.2 | 34.2 | 26.8 | | | | | 22.8 | 20.4 | | | | | | | | | | | | 90 |
| 95 | | 33.7 | 26.7 | 20.6 | | | | 22.5 | 20.3 | | | | 17.1 | 14.8 | | | | | | | 95 |
| 100 | | 33 | 26.7 | 20.6 | | | | | 20.1 | 15.5 | | | 16.9 | 14.8 | | | 11.6 | | | | 100 |
| 105 | | | 26.7 | 20.6 | | | | | 19.8 | 15.5 | | | | 14.8 | | | 11.6 | | | | 105 |
| 110 | | | 26.6 | 20.5 | 16.3 | | | | 19.4 | 15.5 | 10.9 | | | 14.6 | 9.9 | | 11.6 | | | | 110 |
| 115 | | | 26.4 | 20.5 | 16.3 | 11.9 | | | | 15.4 | 10.9 | | | 14.4 | 9.9 | | | | | | 115 |
| 120 | | | 26.1 | 20.5 | 16.3 | 11.9 | | | | 15.4 | 10.9 | 7 | | | 9.9 | 6.1 | | | | 5.3 | 120 |
| 125 | | | | 20.5 | 16.3 | 11.9 | | | | 15.2 | 10.9 | 7 | | | 9.9 | 6.1 | | | | 5.3 | 125 |
| 130 | | | | 20.5 | 16.2 | 11.9 | 8 | | | 15 | 10.9 | 7 | | | 9.9 | 6.1 | | | | 5.3 | 130 |
| 135 | | | | 20.5 | 16.2 | 11.9 | 8 | | | | 10.9 | 7 | | | 9.9 | 6.1 | | | | 5.3 | 135 |
| 140 | | | | 20.5 | 16.2 | 11.9 | 8 | | | | 10.9 | 7 | | | | 6.1 | | | | 5.3 | 140 |
| 145 | | | | | 16.2 | 11.9 | 8 | | | | 10.9 | 7 | | | | 6.1 | | | | | 145 |
| 150 | | | | | 16.2 | 11.9 | 8 | | | | 10.9 | 7 | | | | 6.1 | | | | | 150 |
| 155 | | | | | 16.2 | 11.9 | 8 | | | | 10.9 | 7 | | | | 6.1 | | | | | 155 |
| 160 | | | | | 16.2 | 11.9 | 8 | | | | | 7 | | | | | | | | | 160 |
| 165 | | | | | 16.2 | 11.9 | 8 | | | | | 7 | | | | | | | | | 165 |
| 170 | | | | | 16.2 | 11.9 | 8 | | | | | 7 | | | | | | | | | 170 |
| 175 | | | | | | 11.9 | 8 | | | | | 7 | | | | | | | | | 175 |
| 180 | | | | | | 11.9 | 8 | | | | | | | | | | | | | | 180 |
| 185 | | | | | | 11.9 | 8 | | | | | | | | | | | | | | 185 |
| 190 | | | | | | 11.9 | 8 | | | | | | | | | | | | | | 190 |
| 195 | | | | | | | 8 | | | | | | | | | | | | | | 195 |
| 200 | | | | | | | 8 | | | | | | | | | | | | | | 200 |
| 205 | | | | | | | 8 | | | | | | | | | | | | | | 205 |
| 210 | | | | | | | 8 | | | | | | | | | | | | | | 210 |
| 215 | | | | | | | 8 | | | | | | | | | | | | | | 215 |

* adapter · pièce d'adaptateur

TAB 131221

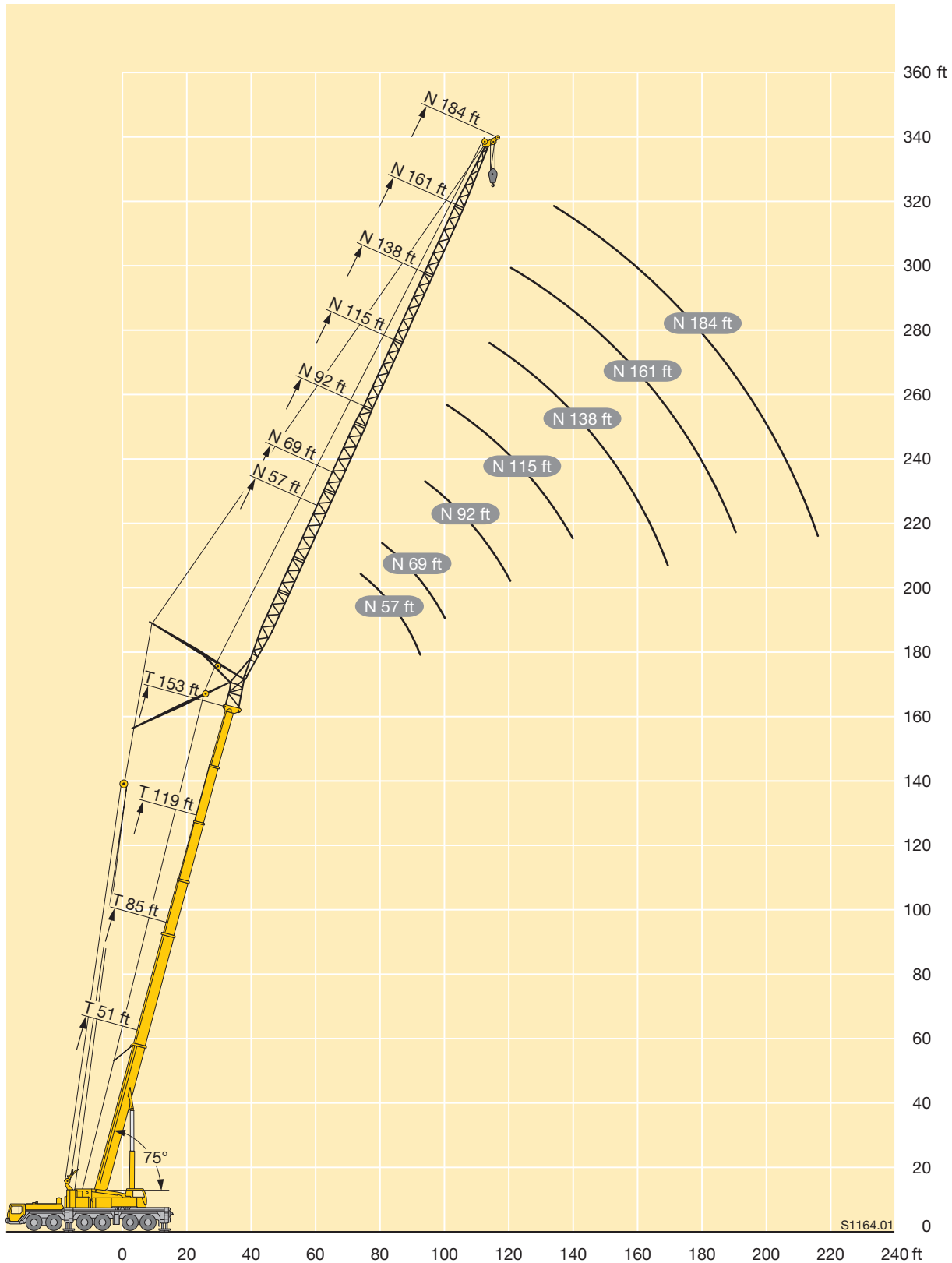

Lifting capacities Forces de levage

TN

51 - 119 ft
 68° T

57 - 230 ft

360°

187400 lbs

85%

| ft | 51 ft + 10 ft* | | | | | | | | 85 ft + 10 ft* | | | | | | | | 119 ft + 10 ft* | | | | | | | | ft | | | | |
|-----|----------------|-------|-------|--------|--------|--------|--------|--------|----------------|-------|-------|-------|--------|--------|--------|--------|-----------------|--------|-------|-------|-------|--------|--------|--------|------|--------|--------|------|-----|
| | 57 ft | 69 ft | 92 ft | 115 ft | 138 ft | 161 ft | 184 ft | 207 ft | 230 ft | 57 ft | 69 ft | 92 ft | 115 ft | 138 ft | 161 ft | 184 ft | 207 ft | 230 ft | 57 ft | 69 ft | 92 ft | 115 ft | 138 ft | 161 ft | | 184 ft | 207 ft | | |
| 55 | 93.5 | | | | | | | | | | | | | | | | | | | | | | | | | | 55 | | |
| 60 | 92.5 | 89 | | | | | | | | | | | | | | | | | | | | | | | | | 60 | | |
| 65 | 89 | 84 | | | | | | | 81 | | | | | | | | | | | | | | | | | | 65 | | |
| 70 | 82.5 | 81 | | | | | | | 77 | | | | | | | | | | | | | | | | | | 70 | | |
| 75 | | 78.5 | 69.5 | | | | | | 73 | 72 | | | | | | | | | | | | | | | | | 75 | | |
| 80 | | 74 | 67.5 | | | | | | 69.5 | 68 | | | | | | | | | | | | | | | | | 80 | | |
| 85 | | 62 | 66 | 54.9 | | | | | 66.5 | 64.5 | 60 | | | | | | | | 48.4 | | | | | | | | 85 | | |
| 90 | | | 65 | 53.9 | | | | | | 62 | 58.6 | | | | | | | | 46.2 | 44.6 | | | | | | | 90 | | |
| 95 | | | 62.5 | 52.9 | 43.2 | | | | | | 56.6 | 46.8 | | | | | | | 44.2 | 43.3 | | | | | | | 95 | | |
| 100 | | | 57.6 | 52.2 | 43 | | | | | | 54.5 | 46.6 | | | | | | | | 41.4 | 37.7 | | | | | | 100 | | |
| 105 | | | | 51.8 | 42.2 | 35 | | | | | 52.6 | 46.1 | | | | | | | | | 37.7 | | | | | | 105 | | |
| 110 | | | | 51.5 | 41.5 | 34.4 | | | | | 50.5 | 45.7 | 37 | | | | | | | | 36.3 | | | | | | 110 | | |
| 115 | | | | 49.5 | 41 | 33.8 | 27.4 | | | | 48.1 | 45.2 | 36.8 | | | | | | | | 35 | 32 | | | | | 115 | | |
| 120 | | | | 45.9 | 40.7 | 33.3 | 27.3 | | | | | 44.4 | 36.5 | 28.9 | | | | | | | 33.8 | 31.6 | 26.7 | | | | 120 | | |
| 125 | | | | | 40.4 | 32.8 | 26.9 | | | | | 43 | 36.2 | 28.9 | | | | | | | 32.6 | 30.5 | 26.7 | | | | 125 | | |
| 130 | | | | | 39.3 | 32.6 | 26.5 | 21.4 | | | | 41.1 | 36.1 | 28.8 | | | | | | | 31.6 | 29.6 | 26.6 | | | | 130 | | |
| 135 | | | | | 38 | 32.5 | 26.2 | 21.1 | | | | 39.3 | 36 | 28.7 | 22.4 | | | | | | | 28.6 | 26.2 | 21 | | | 135 | | |
| 140 | | | | | 36.3 | 32.5 | 25.9 | 20.7 | 12 | | | | 35.8 | 28.6 | 22.4 | 17.8 | | | | | | 27.8 | 25.6 | 21 | | | 140 | | |
| 145 | | | | | 33.8 | 32.5 | 25.7 | 20.4 | 11.9 | | | | 35.2 | 28.5 | 22.4 | 17.8 | | | | | | 26.9 | 24.9 | 21 | | | 145 | | |
| 150 | | | | | 30.3 | 32.5 | 25.7 | 20 | 11.4 | | | | 33.8 | 28.5 | 22.4 | 17.8 | | | | | | 26.1 | 24.2 | 21 | 16.7 | | 150 | | |
| 155 | | | | | | 31.9 | 25.5 | 19.5 | 11 | | | | 32.4 | 28.5 | 22.2 | 17.8 | 11 | | | | | | 23.6 | 21 | 16.7 | | 155 | | |
| 160 | | | | | | 30.4 | 25.2 | 19.1 | 10.5 | | | | 31.1 | 28.5 | 22 | 17.8 | 10.8 | | | | | | 23 | 20.9 | 16.7 | 12.6 | 160 | | |
| 165 | | | | | | 28.1 | 24.9 | 18.7 | 10.1 | | | | | 28.4 | 21.8 | 17.7 | 10.4 | | | | | | 22.4 | 20.7 | 16.7 | 12.6 | 165 | | |
| 170 | | | | | | 25.4 | 24.6 | 18.3 | 9.7 | | | | | | 27.9 | 21.5 | 17.5 | 10 | | | | | | 21.7 | 20.1 | 16.7 | 12.6 | 170 | |
| 175 | | | | | | | 24.3 | 17.9 | 9.3 | | | | | | 27 | 21.2 | 17.3 | 9.6 | | | | | | 21.3 | 19.6 | 16.7 | 12.6 | 175 | |
| 180 | | | | | | | 23.8 | 17.5 | 8.8 | | | | | | 26 | 21 | 17 | 9.3 | | | | | | | 19.2 | 16.7 | 12.6 | 180 | |
| 185 | | | | | | | 22.9 | 17.1 | 8.5 | | | | | | | 20.8 | 16.7 | 8.9 | | | | | | | | 18.7 | 16.7 | 12.6 | 185 |
| 190 | | | | | | | 21.2 | 16.8 | 8.1 | | | | | | | 20.5 | 16.4 | 8.6 | | | | | | | | 18.2 | 16.5 | 12.6 | 190 |
| 195 | | | | | | | 18.8 | 16.4 | 7.7 | | | | | | | 20.4 | 16.1 | 8.2 | | | | | | | | 17.9 | 16.1 | 12.6 | 195 |
| 200 | | | | | | | | 16.1 | 7.3 | | | | | | | 20.3 | 15.9 | 7.9 | | | | | | | | | 15.8 | 12.6 | 200 |
| 205 | | | | | | | | 15.8 | 7 | | | | | | | 20.3 | 15.6 | 7.5 | | | | | | | | | 15.4 | 12.6 | 205 |
| 210 | | | | | | | | 15.6 | 6.6 | | | | | | | | 15.3 | 7.2 | | | | | | | | | 15.1 | 12.6 | 210 |
| 215 | | | | | | | | 15.4 | 6.3 | | | | | | | | 15.1 | 6.9 | | | | | | | | | 14.8 | 12.6 | 215 |
| 220 | | | | | | | | | 6 | | | | | | | | 14.9 | 6.6 | | | | | | | | | 14.6 | 12.6 | 220 |
| 225 | | | | | | | | | 5.7 | | | | | | | | 14.8 | 6.2 | | | | | | | | | | 12.5 | 225 |
| 230 | | | | | | | | | 5.5 | | | | | | | | | 6 | | | | | | | | | | 12.2 | 230 |
| 235 | | | | | | | | | 5.4 | | | | | | | | | | | | | | | | | | | 12 | 235 |
| 240 | | | | | | | | | 5.2 | | | | | | | | | | | | | | | | | | | 11.8 | 240 |
| 245 | | | | | | | | | | | | | | | | | | | | | | | | | | | | | 245 |
| 250 | | | | | | | | | | | | | | | | | | | | | | | | | | | | | 250 |
| 255 | | | | | | | | | | | | | | | | | | | | | | | | | | | | | 255 |

* adapter · pièce d'adaptateur

TAB 131223

Lifting capacities Forces de levage

TN



| ft | 153 ft + 10 ft* | | | | | | | 187 ft + 10 ft* | | | | | 204 ft + 10 ft* | | 221 ft + 10 ft* | ft |
|-----|-----------------|-------|-------|--------|--------|--------|--------|-----------------|-------|-------|--------|--------|-----------------|--------|-----------------|-----|
| | 57 ft | 69 ft | 92 ft | 115 ft | 138 ft | 161 ft | 184 ft | 57 ft | 69 ft | 92 ft | 115 ft | 138 ft | 92 ft | 115 ft | 92 ft | |
| 95 | 31.9 | | | | | | | | | | | | | | | 95 |
| 100 | 31.4 | 29.1 | | | | | | | | | | | | | | 100 |
| 105 | 30.1 | 29.1 | | | | | | | | | | | | | | 105 |
| 110 | 28.9 | 28 | | | | | | | | | | | | | | 110 |
| 115 | | 26.9 | 23.7 | | | | | 17 | | | | | | | | 115 |
| 120 | | | 23.5 | | | | | 16.7 | 15.1 | | | | | | | 120 |
| 125 | | | 22.8 | | | | | | 15.1 | | | | | | | 125 |
| 130 | | | 22.2 | 19.2 | | | | | 14.6 | | | | | | | 130 |
| 135 | | | 21.5 | 18.9 | | | | | | 11.9 | | | | | | 135 |
| 140 | | | 20.8 | 18.4 | 15.3 | | | | | 11.7 | | | | | | 140 |
| 145 | | | | 18 | 15.3 | | | | | 11.3 | | | | | | 145 |
| 150 | | | | 17.6 | 15.2 | | | | | 11 | 9 | | 7.5 | | | 150 |
| 155 | | | | 17.2 | 15 | 10.9 | | | | 10.6 | 8.7 | | 7.2 | | 4.4 | 155 |
| 160 | | | | 16.8 | 14.8 | 10.9 | | | | | 8.5 | 6.3 | 7 | 5.1 | 4.4 | 160 |
| 165 | | | | | 14.5 | 10.9 | | | | | 8.2 | 6.3 | | 5.1 | 4.4 | 165 |
| 170 | | | | | 14.3 | 10.9 | 7.5 | | | | 7.9 | 6.3 | | 5.1 | 4.4 | 170 |
| 175 | | | | | 13.9 | 10.9 | 7.5 | | | | 7.7 | 6.1 | | 4.9 | | 175 |
| 180 | | | | | 13.6 | 10.9 | 7.5 | | | | | 6 | | 4.8 | | 180 |
| 185 | | | | | 13.2 | 10.9 | 7.5 | | | | | 5.8 | | | | 185 |
| 190 | | | | | 12.9 | 10.9 | 7.5 | | | | | 5.7 | | | | 190 |
| 195 | | | | | | 10.9 | 7.5 | | | | | 5.5 | | | | 195 |
| 200 | | | | | | 10.7 | 7.5 | | | | | 5.4 | | | | 200 |
| 205 | | | | | | 10.4 | 7.5 | | | | | | | | | 205 |
| 210 | | | | | | | 7.5 | | | | | | | | | 210 |
| 215 | | | | | | | 7.5 | | | | | | | | | 215 |
| 220 | | | | | | | 7.5 | | | | | | | | | 220 |
| 225 | | | | | | | 7.5 | | | | | | | | | 225 |
| 230 | | | | | | | 7.5 | | | | | | | | | 230 |
| 235 | | | | | | | 7.5 | | | | | | | | | 235 |

* adapter · pièce d'adaptateur

TAB 131223

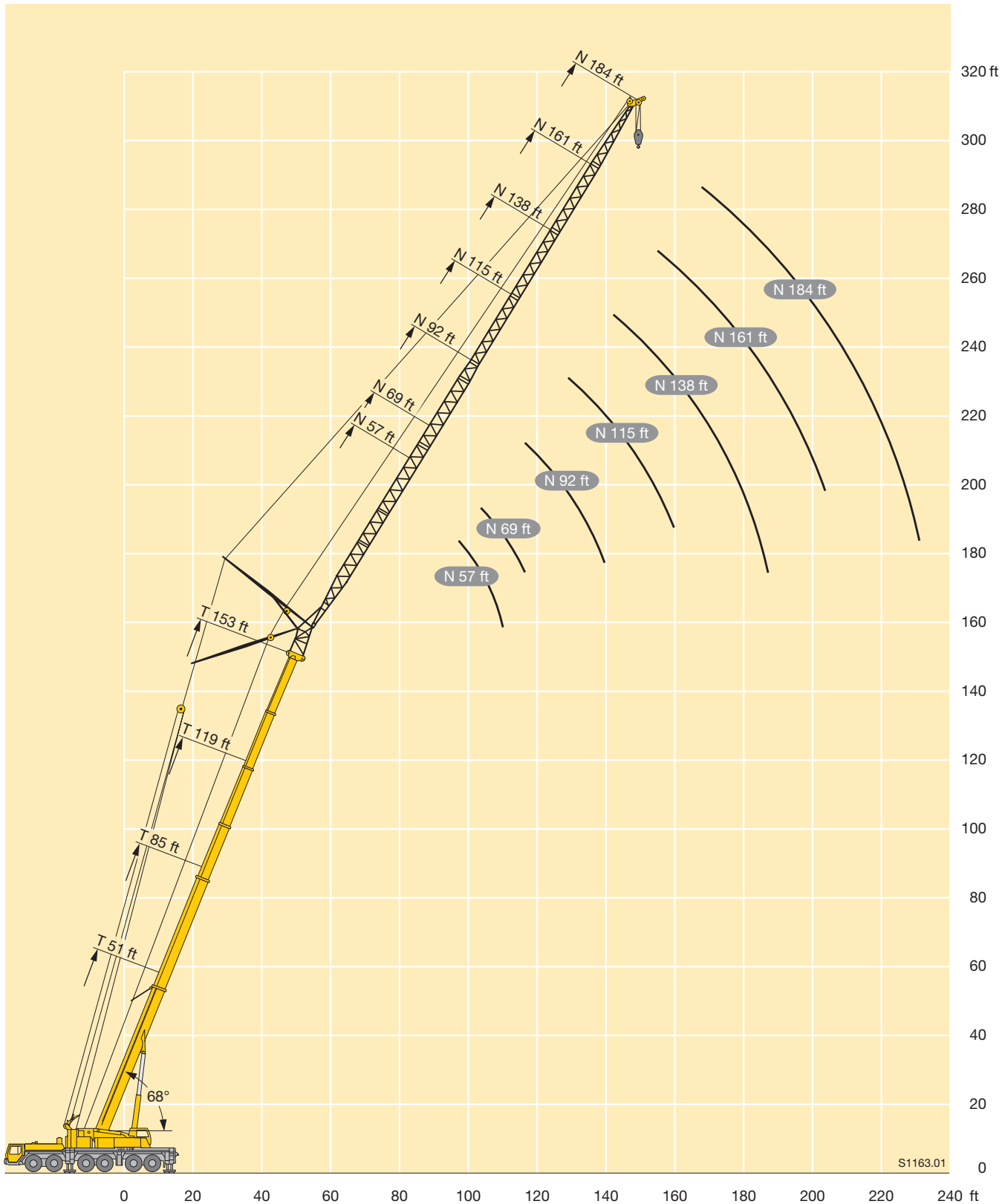

Equipment Equipement

Crane carrier

| | |
|--------------------------|---|
| Frame | Liebherr designed and manufactured, box-type, torsion resistant design of high-tensile fine grained structural steel. |
| Outriggers | Four hydraulically extendable sliding beams with hydraulic jacks and supporting pads. The front outrigger casing is mounted between axles 2 and 3 and the rear casing is located at the rear of the carrier. |
| Engine | 8-cylinder Diesel engine, make Liebherr, watercooled, output 450 kW (612 h.p.), max. torque 2095 lbs-ft. Exhaust emissions acc. to 97/68/EG and EPA/CARB. Fuel reservoir: 141 gallons. |
| Transmission | Automatic transmission system with converter control clutch, make ZF, type TC-TRONIC with 12 forward speeds and 2 reverse speeds, transfer case with transfer differential. |
| Axles | Crane carrier axles of minor maintenance. All axles suspended. Axles 1 to 3 and 5 and 6 steered. Axles 1, 5 and 6 are planetary axles, intermediate differential at axle 5, all driven axles with transverse differential locks. |
| Cardan shaft | All cardan shafts with 70° diagonal toothing and maintenance-free. |
| Suspension | All axles with hydropneumatic suspension and automatic levelling system. Load equalization between the axle pairs 1 + 2, 3 + 4 and 5 + 6. The suspension can be locked hydraulically. |
| Tyre equipment | 12 tyres, all axles equipped with single tyres. Size of tyres: 445/95 R 25 (16.00 R 25). |
| Steering | ZF semi-integral power steering, dual circuit system with hydraulic servo-system and additional backing pump driven by an axle. |
| Brakes | Service brake: All-wheel servo-air brake, dual circuit system. Supplementary brakes: Exhaust brake with Liebherr supplementary brake system, retarder in the automatic transmission. Hand brake: Spring-loaded, acting on all wheels of axles 2 to 6. |
| Driving cab | Spacious sheet steel cab, cataphoretic dip-primed, mounted on rubber shock absorbers, safety glass windows, operating and control elements. |
| Electrical system | Modern data bus technique, 24 Volt DC, 2 batteries of 170 Ah each. |

Crane superstructure

| | |
|---------------------|---|
| Frame | Liebherr-made torsion resistant, welded construction of high-tensile structural steel, linked to carrier by a roller slewing rim for 360° continuous rotation. |
| Crane engine | 4-cylinder Diesel, make Liebherr, watercooled, output 180 kW (245 h.p.), max. torque 840 lbs-ft. Exhaust emissions acc. to 97/68/EG and EPA/CARB. Fuel reservoir: 72 gallons. |

| | |
|------------------------|--|
| Crane drive | Diesel-hydraulic, with 5 axial piston variable displacement pumps, with servo-control and capacity control. |
| Crane control | Two self-centering control levers (joy-sticks). Electronic control by means of the LICCON system, infinitely variable crane motions through displacement control of the hydraulic pumps. Additional working speed control by variation of the Diesel engine speed. |
| Hoist gear | Axial piston variable displacement motor, Liebherr hoist drum with integrated planetary gear and spring-loaded static brake. |
| Luffing gear | 1 differential hydraulic rams with nonreturn valve. |
| Slewing gear | Hydraulic motor, planetary gear, slewing pinion and spring-loaded static brake. |
| Crane cab | Galvanized steel construction, powder coating, safety glazing, operating and control elements. Cab tiltable backwards by 20°. |
| Safety devices | LICCON safe load indicator, test system, hoist limit switches, safety valves against rupture of pipes and hoses. |
| Counterweight | 159800 lbs counterweight comprising 1 basic slab of 22000 lbs and 3 slabs of 27500 lbs each, 2 lateral hang on slabs of 27500 lbs each. |
| Telescopic boom | 1 base section and 5 telescopic sections. All telescopic sections extendable individually by means of the rapid-cycle telescoping system TELEMATIK. Boom length 51 ft to 236 ft. |
| Electric system | Modern data bus technique, 24 Volt DC, 2 batteries of 170 Ah each. |

Additional equipment

| | |
|--------------------------------------|---|
| Folding jibs | Single folding jib, 40 ft long, for mounting on telescopic boom at 0°, 20° or 40°. Double folding jib, 40 ft to 72 ft long, for mounting on telescopic boom at 0°, 20° or 40°. |
| Intermediate sections | 2 intermediate sections of 23 ft each for the extension of the biparted swing-away jib to 95 ft or 118 ft. |
| Lattice jibs | Fixed lattice jib 46 ft to 138 ft long, installation at 0°, 20° or 40°, luffing lattice jib 57 ft to 230 ft long. |
| 2nd hoist gear | For 2-hook operation or for operating the luffing lattice jib. |
| Additional counterweight | 2 additional lateral hang on slabs of 27500 lbs each for a total counterweight of 214900 lbs. |
| Tyre equipment | 12 tyres, all axles with single tyres. Tyre size 525/80 R 25 (20.5 R 25). |
| Drive 12 x 8 | Axle 3 additionally driven. |
| TELMA-type eddy current brake | Fitted to the 4 th axle for increasing the sustained-action braking performance. |

Other items of equipment available on request.

Equipment Equipment

Châssis porteur

| | |
|--------------------------------|---|
| Châssis | Fabrication Liebherr, construction en caisson indéformable, en acier à haute résistance à grains fins. |
| Stabilisateurs | Quatre poutres horizontales télescopiques, avec vérins hydrauliques de calage verticaux et patins. Les caissons de poutres de calage avants sont situés entre les essieux 2 et 3, et les caissons des poutres de calage arrières sont situés à l'arrière du châssis. |
| Moteur | Moteur diesel, 8 cylindres, fabriqué par Liebherr, à refroidissement par eau, de 450 kW (612 ch), couple max. 2095 lbs-ft. Emissions des gaz d'échappement conformes aux directives 97/68/EG et EPA/CARB. Capacité du réservoir à carburant: 141 gallons. |
| Boîte de vitesse | Boîte automatique avec convertisseur-embayage, marque ZF, type TC-TRONIC avec 12 marches AV et 2 marches AR, boîte de transfert avec différentiel répartiteur. |
| Essieux | Essieux de la grue exempts d'entretien, les 6 essieux sont suspendus. Les essieux 1 à 3, 5 et 6 sont directeurs. Les essieux 1, 5 et 6 sont des essieux planétaires, entraînés, différentiel intermédiaire à l'essieu 5, tous les essieux moteurs sont munis de dispositifs de blocage du différentiel transversal. |
| Arbres articulés | Tous les arbres articulés à denture étagée de 70° et exempts d'entretien. |
| Suspension | Tous les essieux sont suspendus hydropneumatiquement avec mise à niveau et équilibrage entre essieux automatiques. Egalisation de la charge par essieu entre essieux 1 + 2, 3 + 4 et 5 + 6. Suspension blocable hydrauliquement. |
| Pneumatiques | 12 roues à monte simple. Taille: 445/95 R 25 (16.00 R 25). |
| Direction | Direction semi-bloc ZF, à double circuit, assistée hydrauliquement, avec pompe auxiliaire entraînée par un essieu. |
| Freins | Frein de service: à double circuit assisté pneumatiquement, sur toutes les roues. Freins supplémentaires: frein à clapet d'échappement avec système de freinage supplémentaire Liebherr, ralentisseur dans la boîte automatique. Frein de secours et frein à main: par cylindres à ressorts sur les essieux 2 à 6. |
| Cabine | Cabine spacieuse, tôle d'acier, revêtue anti-corrosion par bain de cataphorèse, suspendue sur silent blocs, vitrage de sécurité, tableau de bord complet. |
| Installation électrique | Technique moderne de transmission de données par BUS de données, courant continu 24 Volts, 2 batteries de 170 Ah chacune. |

Partie tournante

| | |
|----------------|---|
| Châssis | Construction mécanosoudée en tôle d'acier à haute résistance à grains fins. Reliée au porteur par une couronne d'orientation à 3 rangées de rouleaux. Rotation totale 360°. |
|----------------|---|

| | |
|----------------------------|--|
| Moteur | Moteur diesel Liebherr, 4 cylindres, à refroidissement par eau, de 180 kW (245 ch), couple max. 840 lbs-ft. Emissions des gaz d'échappement conformes aux directives 97/68/EG et EPA/CARB. Capacité du réservoir à carburant: 72 gallons. |
| Entraînement | Diesel hydraulique à 3 pompes à débit variable servo commandées à régulation de puissance. |
| Commande | 2 leviers à 4 directions avec rappel automatique au point mort. Commande électronique via le dispositif LICCON. Commande des mouvements progressive en continu par variation de l'inclinaison des pompes et augmentation du régime moteur. |
| Treuil | Moteur hydraulique à cylindrée variable, treuil de marque Liebherr avec réducteur planétaire à frein d'arrêt à lamelles intégrées. |
| Relevage de flèche | 1 vérin hydraulique différentiel avec clapet anti-retour de sécurité. |
| Orientation | Un moteur hydraulique, un réducteur planétaire, un pignon d'orientation et un frein à lamelles. |
| Cabine de grue | En tôle d'acier galvanisée, peinte par poudre polyester et cuisson au four, avec vitrage de sécurité, dotées de tous les éléments de contrôle et de commande, cabine inclinable vers l'arrière de 20°. |
| Sécurités | Contrôleur de charge LICCON, système test, fin de course crochet haut, clapets de sécurité en cas de ruptures de flexibles. |
| Contrepoids | 159800 lbs, composé d'une plaque de base de 22000 lbs et 3 plaques de 27500 lbs unitaires, 2 blocs latéraux de suspension de 27500 lbs. |
| Flèche télescopique | Un élément de base et de 5 télescopes. Chaque partie peut être télescopée individuellement à l'aide du système de télescopage séquentiel rapide TELEMATIK. Longueur de flèche: 51 ft – 236 ft. |
| Circuit électrique | Technique moderne de transmission de données par BUS de données. Courant continu 24 Volts, 2 batteries de 170 Ah chacune. |

















Équipement supplémentaire

| | |
|-----------------------------------|---|
| Fléchettes pliante | Fléchette pliante, 40 ft, pour le montage à la flèche télescopique à 0°, 20° ou 40°. Fléchette pliante double, 40 ft à 72 ft, pour montage à la flèche télescopique à 0°, 20° ou 40°. |
| Éléments intermédiaires | 2 éléments intermédiaires de 23 ft de long pour l'allongement de la fléchette pliante double jusqu'à 95 ft resp. 118 ft. |
| Fléchettes | Fléchette fixe de 46 ft à 138 ft; montable à 0°, 20° ou 40° fléchette à volée variable de 57 ft à 230 ft. |
| Deuxième treuil | Pour le travail avec 2 crochets ou le relevage de la fléchette à volée variable. |
| Contrepoids complémentaire | 2 blocs latéraux de suspension de 27500 lbs pour un contrepoids total de 214900 lbs. |
| Pneumatiques | 12 fois, tous les essieux munis de roues simples. Taille 525/80 R 25 (20.5 R 25). |
| Entraînement 12 x 8 | 3ème essieu est entraîné additionnellement. |
| Frein Telma | Monté sur le 4ème essieu pour augmenter la puissance de freinage continu. |





Autres équipements supplémentaires sur demande.

Description of symbols Explication des symboles

General symbols Symboles généraux

| | | | |
|---|---|---|---|
|  | Outriggers Calage |  | Driving speed Vitesse de translation |
|  | Axle Essieu |  | Gear Vitesse |
|  | Radius Portée |  | Hookblock / Capacity Moufle à crochet / Capacité de charge |
|  | Boom length Longueur de la flèche |  | Hoist gear Treuil de levage |
|  | Boom position Position de la flèche |  | Crane carrier Châssis porteur |
|  | Counterweight Contrepoids |  | Crane superstructure Partie tournante de la grue |
|  | Tyres Pneumatiques |  | Standard Norme |
|  | Slewing gear / Working area 360° Mécanisme d'orientation / Plage de travail 360° |  | Gradability Aptitude à gravir les pentes |

Crane specific symbols Symboles spécifiques à la grue

| | | | |
|---|---|---|---|
|  | Telescopic boom Flèche télescopique |  | Fixed lattice jib Fléchette fixe |
|  | Swing away jib Fléchette pliante |  | Luffing lattice jib Fléchette à volée variable |
|  | Hydraulic swing away jib Fléchette pliante hydraulique | | |

Remarks referring to load charts

1. The lifting capacities do not exceed 85 % of the tipping load according to ASME B 30.5.
The crane's structural steelwork is in accordance with EN 13000 and ASME B 30.5.
2. For the calculation of the load charts at least a wind speed of 23 ft/s (7 m/s, 15.7 mph) and regarding the load a sail area of 1 m² per ton load and a wind resistance coefficient of 1.2 on the load have been taken into account. For lifting of loads with large sail areas and/or high wind resistance coefficients the maximum wind speed as stated in the load charts has to be reduced.
3. Lifting capacities are given in kips.
4. The weight of the hook blocks and hooks is part of the load and therefore it must be deducted from the lifting capacities.
5. Working radii are measured from the slewing centre.
6. The lifting capacities given for the telescopic boom apply if the folding jib is removed.
7. Subject to modification of lifting capacities.
8. Lifting capacities above 298 kips only with additional pulley block/special equipment.
9. The data of this brochure serves only for general information. All information is provided without warranty. Instructions for the correct commissioning of the crane please take from the operation manual and the load chart book.

Remarques relatives aux tableaux des charges

1. La capacité de charge ne doit pas dépasser 85 % de la charge de basculement conformément à ASME B 30.5.
La structure métallique de la grue est conforme à EN 13000 et ASME B 30.5.
2. Une vitesse de vent de 23 ft/s (7 m/s, 15.7 mph) minimum, une surface de prise au vent de 1 m² par tonne ainsi qu'un coefficient de résistance au vent de la charge 1,2 sont pris en compte pour le calcul des tableaux de charge. Lorsque des charges ayant une surface de prise au vent et/ou un coefficient de résistance au vent plus élevé(e)s sont levées, la vitesse de vent maximale indiquée dans les tableaux de charge doit être réduite.
3. Les charges sont indiquées en kips.
4. Le poids du crochet de levage resp. de la moufle à crochet est une partie de la charge et doit donc être déduit de la capacité de charge.
5. Les portées sont calculées à partir de l'axe de rotation.
6. Les charges indiquées pour la flèche télescopique sont valables lorsque la fléchette pliante est démontée.
7. Charges données sous réserve de modification.
8. Forces de levage plus de 298 kips seulement avec moufle additionnel/équipement supplémentaire.
9. Les données de cette brochure sont données à titre informatif. Ces renseignements sont sans garantie. Les consignes relatives à la bonne mise en service de la grue sont disponibles dans le manuel d'utilisation et le manuel de tableaux de charge.