

# Mobile crane Product advantages

# LTM 1300-6.1

**Max. lifting capacity: 300 t at 3 m radius**

**Max. height under hook: 116 m with lattice luffing jib**

**Max. radius: 92 m with lattice luffing jib**



# LIEBHERR

*Courtesy of Crane.Market*

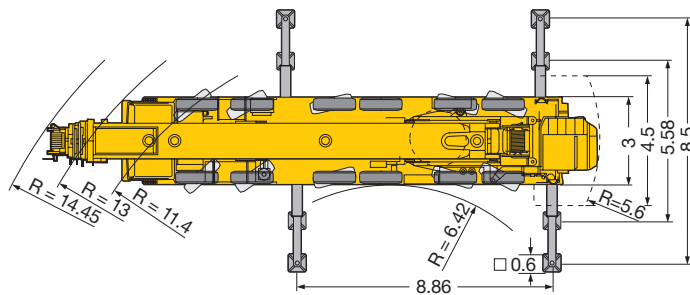
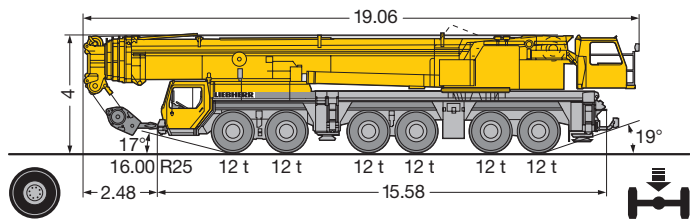

## Compact, manoeuvrable and safe

- Overall length 19 m, length of carrier 15.3 m
- Large front and rear overhang angles, front up to 17°, rear up to 19°
- Small turning radius due to 5-axle steering (13.1 m over carrier)
- Equal axle load distribution (12 t) due to the hydropneumatic suspension „Niveaumatik“
- 12.5 t basic counterweight, biparted swing-away jib and telescopic boom guying system can be transported with the crane
- In addition to the service and parking brakes, the following sustained-action brakes for safe travel are part of the standard equipment: retarder (in the automatic transmission), TELMA-type eddy current brake on 4th axle and exhaust brake with Liebherr auxiliary brake system by valve control (ZBS).

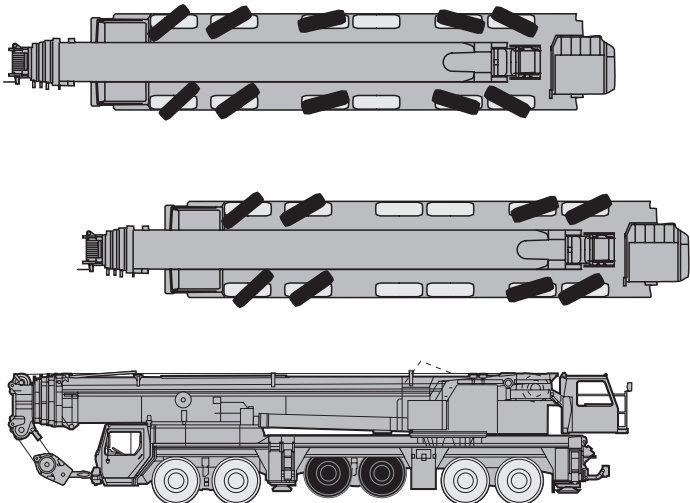

## Variable drive and steering concept

- Standard 5-axle steering, 5th and 6th axle can also be steered independent from axles 1 - 3. During crab steering/diagonal displacement, axles 3 and 4 are raised hydraulically
- Drive 12 x 6, axles 1, 5 and 6 are driven
- Drive 12 x 8, axles 1, 3, 5 and 6 are driven, 3rd axle can be activated for off-road travel
- Electronically controlled Allison automatic transmission type CLBT 755 with 5 forward speeds and 1 reverse gear, a robust and reliable automatic gear which decisively improves the driving comfort
- Transfer case with off-road ratio and transfer differential
- Driving axles with differential locks for transvers locking in off-road ratio

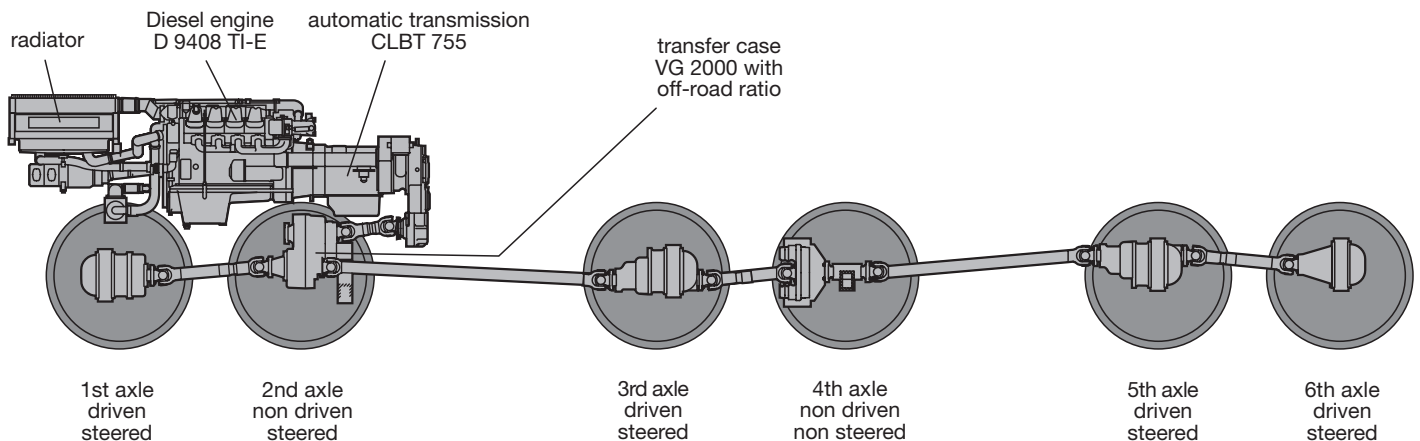

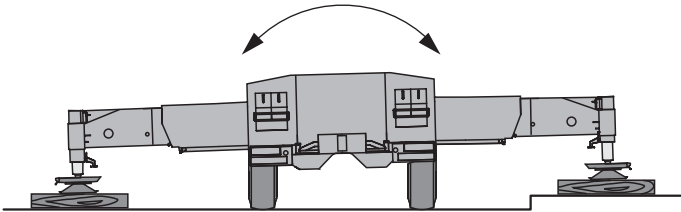
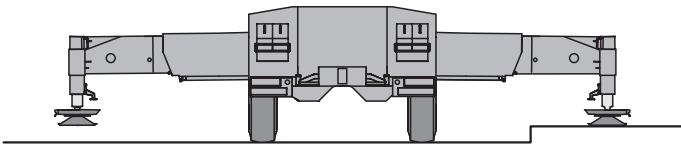
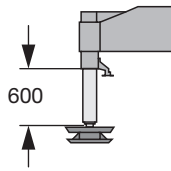

## Setting crane on outriggers - quick, convenient and safe

- Supporting basis 8.85 m x 8.5 m or 8.85 m x 5.58 m
- Fixed lightweight supporting pads (plastic) with lateral compensation
- Supporting rams with 600 mm travel
- Level control of supporting system, automatic levelling of the crane during the supporting procedure by „push-button control“
- 2 x 9° lateral inclination even with locked suspension
- Inclinometer (electronic display of inclination) with two indicators on the carrier and display on the LICCON monitor in the crane cabin
- 2 indicators of supporting forces in the control panels on the carrier and on the LICCON monitor
- Control of outriggers with display of the state of extension on the LICCON monitor (optional)
- Operation of the outriggers in accordance with the rules for the prevention of accidents

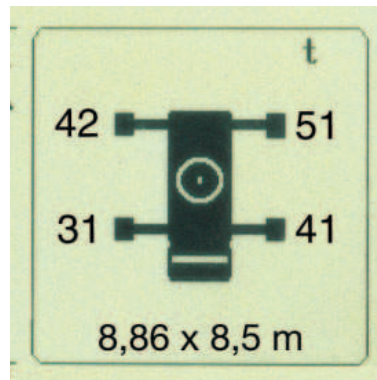

### Ultra-modern boom technology

- Focal points of the new boom technology:
  - optimized oviform boom profile
  - patented internal interlocking system of the telescopes
  - automatic telescoping system „Telematik“
- Telescopic boom with electronically controlled telescoping system
- Boom bearings of low maintenance polyamide slide blocks
- Outstanding lifting capacities, e.g.
  - 87.0 t at 10 m radius
  - 42.5 t at 20 m radius
  - 25.9 t at 30 m radius
  - 16.9 t at 40 m radius
  - 10 t at 60 m radius
  - 1.1 t at 92 m radius

### Powerful carrier drive

- 8-cylinder Liebherr turbo-charged Diesel engine type D 9408 TI-E with charge cooling, 440 kW/598 h.p. (EURO 3), energy-saving, emission-optimized, robust and reliable, electronic engine management
- Allison automatic transmission with torque converter and hydrodynamic brake, electronic transmission management, 5 forward speeds and 1 reverse gear, proved and well tested serial transmission
- 2-step, robust transfer case with transfer differential
- Robust crane axles, welded design
- Max. driving speed 76 km/h, max. gradability 43 %

### Weight-optimized steel structure of the crane

- Carrier, superstructure and telescopic boom in light-gauge design, calculated by the F.E.M. method and thus weight-optimized; particularly torsionally rigid structural components
- Tensile property of material with high safety factors through the application of STE 960 (960 N/mm<sup>2</sup>) for all supporting members
- Hydraulic oil and fuel tanks as well as trim panels made of aluminium

### Crane drive with proved components

- 4-cylinder Liebherr turbo-charged Diesel engine type D 924 TI-E with charge cooling, 180 kW/245 h.p., engine speed controlled electronically, engine easy-to-service located at right angles to the rear of the superstructure
- Enclosed „power pack“ (dieselhydraulic drive assembly) for reduced noise emission
- Pump distribution gear with 4 servo-controlled axial piston variable displacement pumps operating in a closed oil circuit for winches 1, 2, 3 and slewing gear, 1 servo-controlled double axial variable displacement pump operating in an open oil circuit for luffing/telescoping; oil cooler in the hydraulic oil circuit

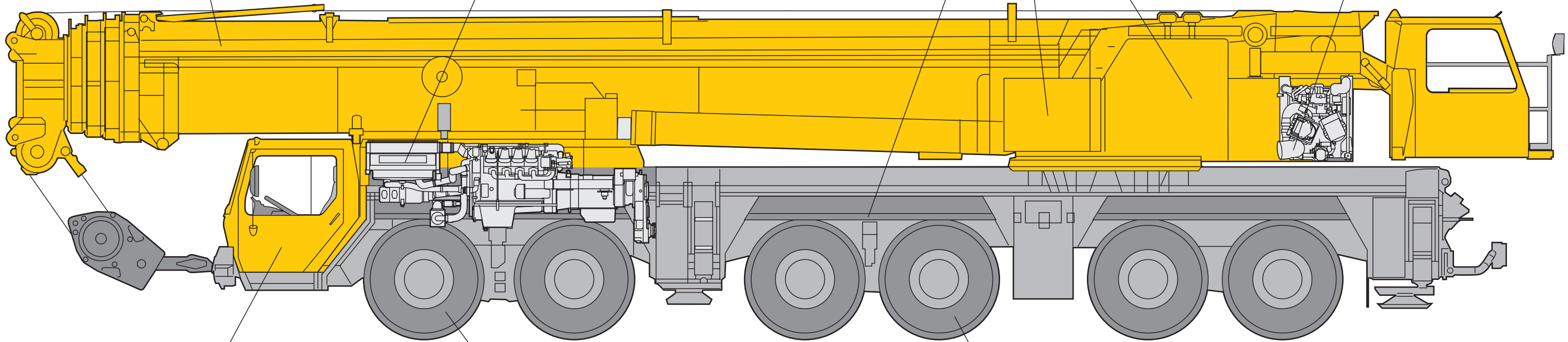

### Data bus technique revolutionizes crane electric system

- The data transmission to the individual functional blocks is realized digitally by just a few data cables instead of the traditional electric wiring. Thus, increased reliability due to considerably less contacts
- Self-manufactured Liebherr bus systems (LSB), especially adapted to the requirements of a mobile crane
- The vehicle and crane electrics with all cockpit functions, the outrigger system and boom sensor system are interconnected by 5 Liebherr system busses
- Comprehensive diagnostic facilities, quick localization of errors
- The new data bus technique provides a distinctive increase in functionality and efficiency of the mobile crane

### Outstanding carrier technology for on-road and off-road application

- Weight-optimized axles, almost maintenance-free, made of high-tensile steel, perfect track keeping and lateral stability due to special control linkage arrangement
- The maintenance-free steering knuckles are steel mounted
- The perfected and robust axles are manufactured in large series and are troublefree components
- The cardan shafts are maintenance-free; easy and quick fitting of the cardan shafts due to 70° diagonal toothing and 4 fixing screws

### Crane- and road-preserving Niveaumatik suspension

- Maintenance-free suspension rams, free of lateral forces and protected against damage by synthetic tubes
- Level adjustment (suspension set to „travel mode“) can be performed automatically by push-button control from any position
- Stable cornering ability of the crane due to cross mounting of the hydraulic suspension
- Axle locking system (locking of the suspension for travelling with equipment) integrated into the suspension ram and controllable from the driver's cabin



## Load handling - precise and safe

- 5-section, 60 m long telescopic boom for 60 m height under hook and 58 m radius
- Optimized, oviform boom profile with continuous curvature of the lower shell and joint offset upwards, particular torsional rigidity for the highest load capacities
- Wide boom profile for the strengthening of the lateral neutral axis and the stabilization of long auxiliary jibs
- Patented internal locking system of the telescopes - of functional reliability and maintenance-free
- High functionality of the boom system due to the automatic telescoping system „Telematik“
- Optimal utilization of the telescopic boom through numerous telescoping variants

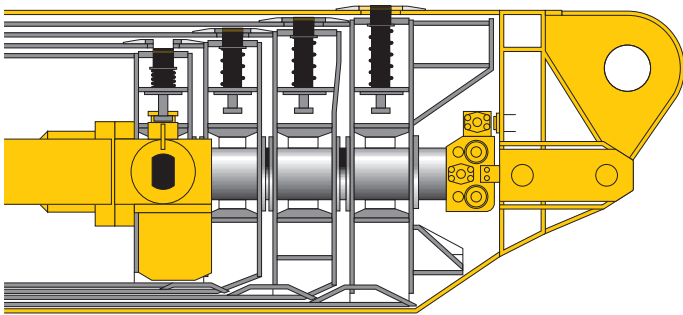

oviform boom profile

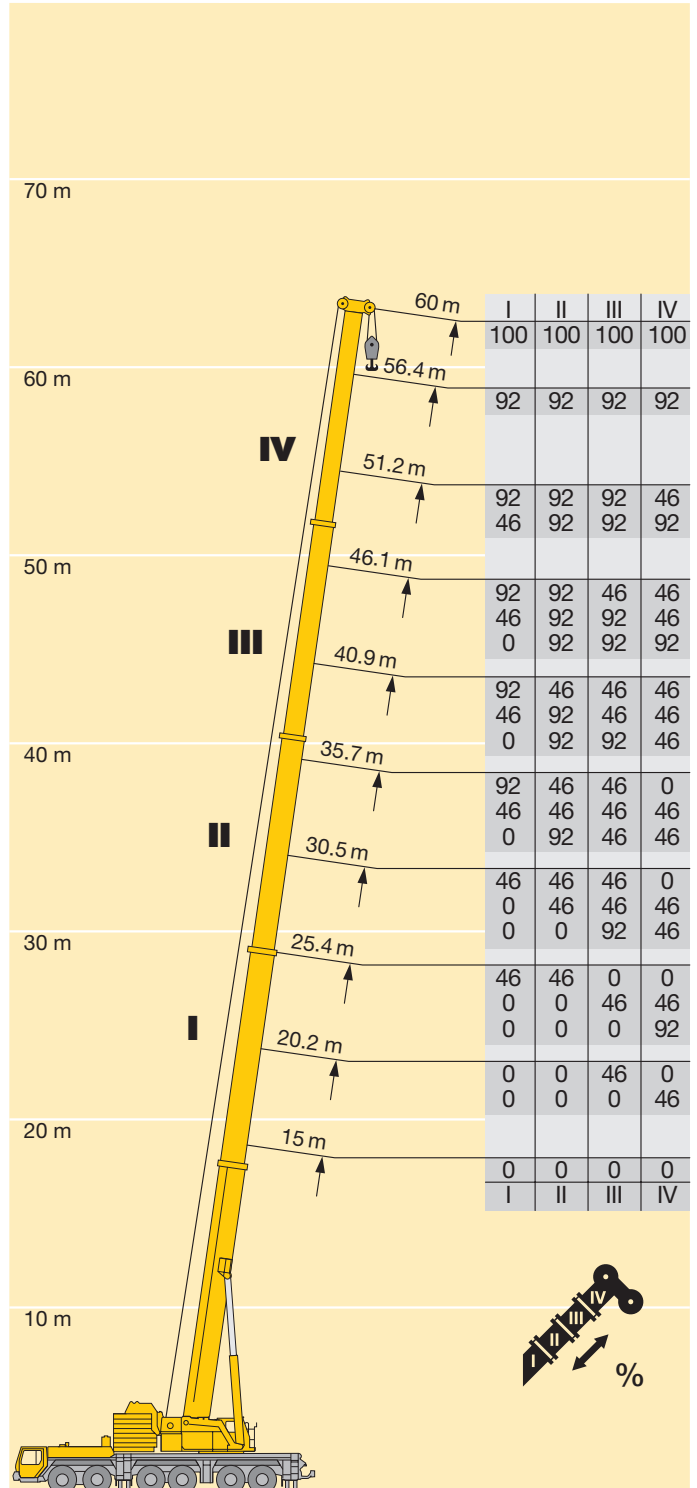
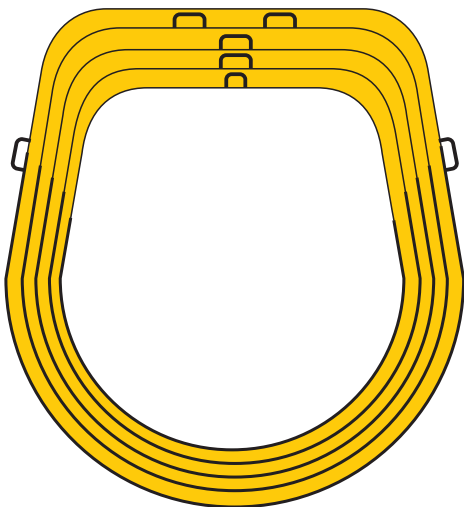

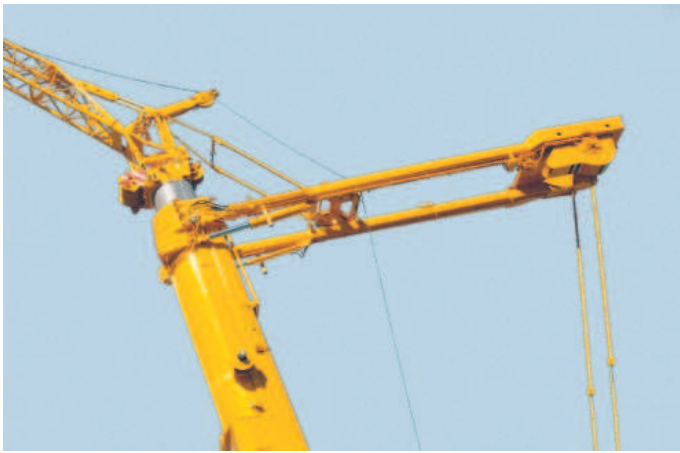

## Multi-variable boom configuration system

- Telescopic boom T, 15 m - 60 m, also with additional guying system TA
- Single swing-away jib K, 12.1 m long, biparted swing-away jib K, 12.1 m - 21 m long, both mountable at 0°, 20° or 40°, also with additional guying system TAK
- Fixed lattice jib TF, 10.5 m - 49 m, mountable at 0°, 20° or 40°, also with additional guying system TAF
- Luffing lattice jib TN, 17.5 m - 70 m, mountable to the 15 m - 56.4 m long telescopic boom at 82°, 74° and 66° inclination, also with additional guying system TAN
- Intermediate sections TF and TN configuration are identical and can be slid into one another for transportation
- Jib A-frames with T-adapter and N-base section form a complete mounting/transport unit and can be mounted with 4 pins only
- Easy-to-rig stay rods which remain on the intermediate sections during transportation
- Standard auxiliary winch on the ballasting frame for easy reeving of the hoist and luffing ropes
- Rigging of the jib is practicable in suspended condition on restricted sites
- Winch 2 for 2-hook operation
- Winch 3 for luffing of the jib
- Stepless load capacity interpolation during luffing of the boom combinations TN or TAN between 82° and 66° inclination of the telescopic boom

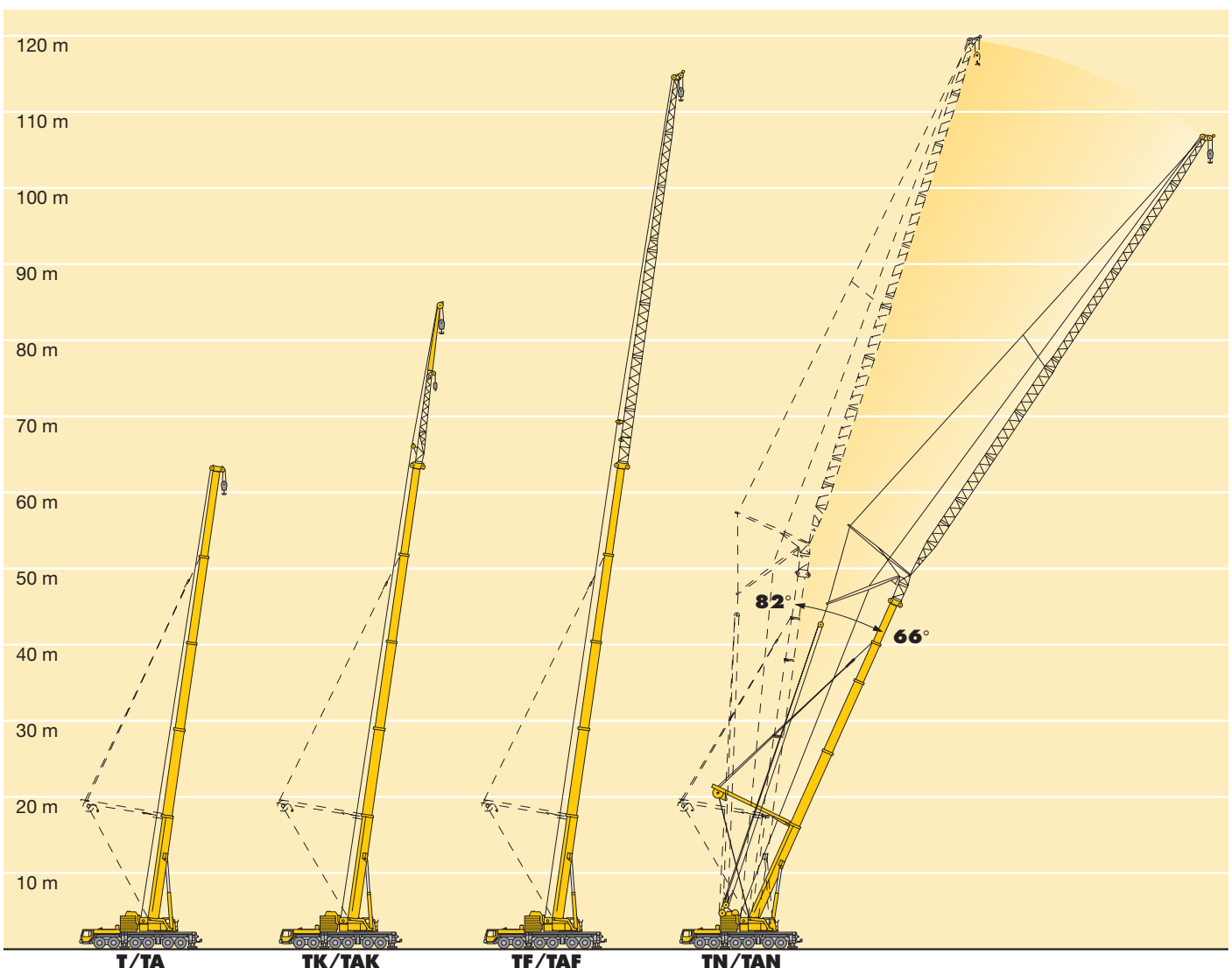

- The electrical and electronic components are interconnected by the most modern data bus transmission technique
- Digital data transmission to the individual functional blocks by only a few data cables instead of the traditional electric wiring; thus increased reliability due to considerably less contacts
- Self-manufactured Liebherr bus systems, especially adapted to the requirements of a mobile crane
- Diesel engine and automatic transmission are controlled via a CAN data bus. The fully electronic drive management reduces fuel consumption and improves the emission of exhaust gases
- The electric systems of the vehicle and crane as well as all cockpit functions, the outrigger system and sensor system of the boom are interconnected by 5 Liebherr system busses
- The control of the functional blocks is realized by I/O modules, the programming of which is performed by means of the Liebherr system busses. The control intelligence is integrated into the LICCON central unit
- Comprehensive diagnostic facilities, quick error location, operating error display
- Test programs for functional test of keyboard and display unit as well as for the test of the control devices of the engine and transmission management, anti-skid system (optional), Liebherr additional brake system, hydraulic ventilator, hydraulic suspension and outrigger operating units
- The new data bus technique distinctively increases functionality and efficiency of the crane

- Legend:
- Yellow line: LSB – Liebherr system bus 1 (also for TN mode)
  - Orange line: LSB – Liebherr system bus 2
  - Red line: LSB – Liebherr system bus 3 (also for TN mode)
  - Blue line: LSB – Liebherr system bus 4
  - Purple line: LSB – Liebherr system bus 5 (also for TA mode)
  - Green line: CAN bus
  - Blue line: CAN bus
  - Green line: SCI – serial communication interface

- 1 Input/out module for electronic control of suspension, Liebherr Diesel engine, automatic transmission, operating functions, compressed air control for brake function
- 2 Input/output module for differential locks, display functions
- 3 Input/output module for outriggers - right
- 4 Input/output module for outriggers - left
- 5 Input/output module for engine brake, tempostat, tempaset, electronic control of Diesel engine (steering column switch, right) and automatic transmission
- 6 Control of Allison automatic transmission
- 7 Control of injection pump Liebherr Diesel engine/carrier
- 8 Slewing sensor within slipping unit
- 9 Connection Liebherr system bus (LSB 1, 2, 3, 4, 5)
- 10 LICCON central unit
- 11 LICCON monitor in the crane cabin (2nd LICCON monitor for TA mode)
- 12 Length sensor and cable drum/energy cable for interlocking of gripper/telescopic boom
- 13 Inductive sensor (12x)
- 14 Angle sensor on base section
- 15 Cable drum for items 16, 17, 18 and jib
- 16 Wind sensor
- 17 Hoist limit switch
- 18 Angle sensor
- 19 Input/output module for electronic control of Diesel engine/superstructure, air flap, ventilator clutch, exhaust flap
- 20 Control injection pump Liebherr Diesel engine/superstructure
- 21 Control sensor
- 22 Pedal for telescoping

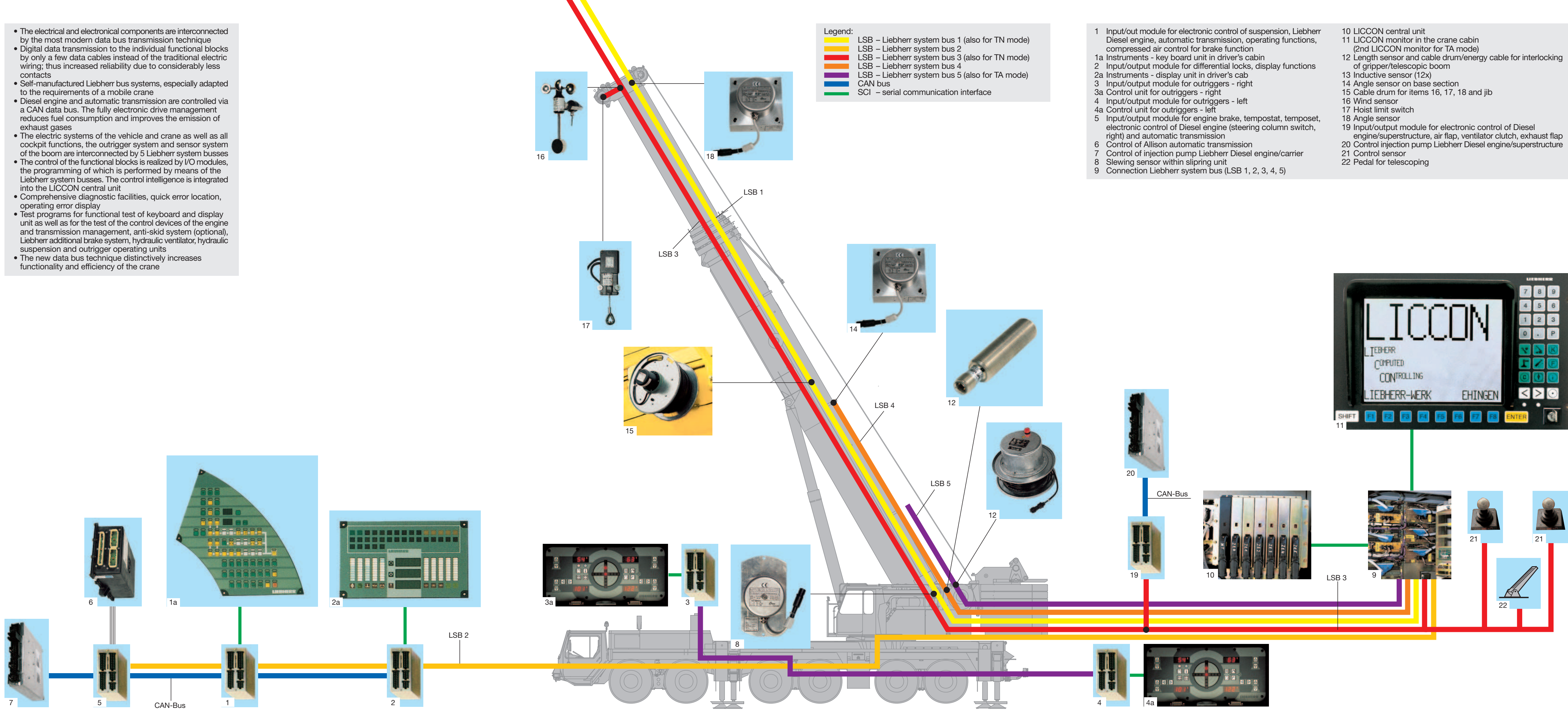



## Comfortable driver's cab of outstanding functionality

- Modern and comfortable driver's cab of modern design
- Heat and sound absorbing internal panelling
- Ergonomically arranged operating and display elements for safe and convenient handling at permanent operation
- Digital display and keyboard units interconnected with the function blocks by data bus technique
- Air-cushioned driver's and co-driver's seats, headrests, driver's seat with pneumatic lumbar support
- Height and inclination adjustable steering wheel
- Heated and electrically adjustable rear mirrors
- Side panes with electric lifters
- Additional engine independent warm water heater „Thermo 90“
- Safety belts for driver and co-driver
- Green-tinted windows for heat absorption
- Automatic windscreen washers/wipers with intermittent control
- Delayed disconnection of interior lighting
- Various racks and boxes
- **Optional equipment**  
Air conditioning, seat heating, 3rd seat with headrest, sleeper berth, cassette radio, and more







## Spacious comfortable crane cabin

- Galvanized crane cab with tinted panes all-round, front knockout window with large parallel windscreen wiper, large skylight of bullet-proof glass with large parallel windscreen wiper, roller blind on skylight, space-saving sliding door, cabin inclinable backwards
- Spring-mounted and hydraulically cushioned crane operator's seat with pneumatic lumbar support and headrest
- Convenient armrest-integrated controls, vertically and horizontally adjustable master switch consoles and armrests, ergonomically inclined operating consoles
- Heat and sound absorbing internal panelling
- Display of all essential operational data on the LICCON monitor



- Green-tinted front and side panes for heat absorption
- Windscreen washers/wipers for front window and skylight
- Two working projectors, 70 watt each, at the front and rear of the cabin
- Additional engine independent warm water heater „Thermo 90“





## LICCON-assisted telescoping system

- Telescoping by single-stage hydraulic ram with hydraulic driving tenons
- Telescoping procedure controllable on the LICCON monitor, convenient and simple guide mode on the monitor, precise approach of the interlocking positions
- Telescopic loads are displayed on the monitor operating image
- „Automatic operation“, fully automatic telescoping to the desired boom length, rapid-cycle telescoping system with high working speeds
- Extremely light telescoping system, thus increase in lifting capacity, especially with long booms and at large radii
- Automatic cushioning of telescopes in end positions during telescoping and retracting for the preservation of structural members

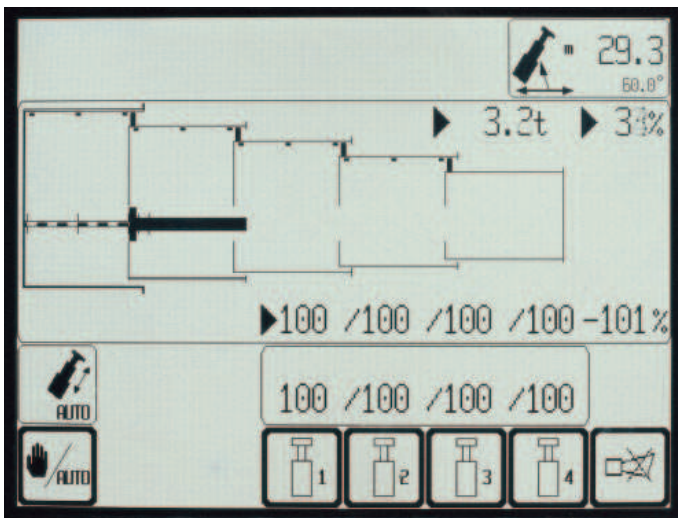
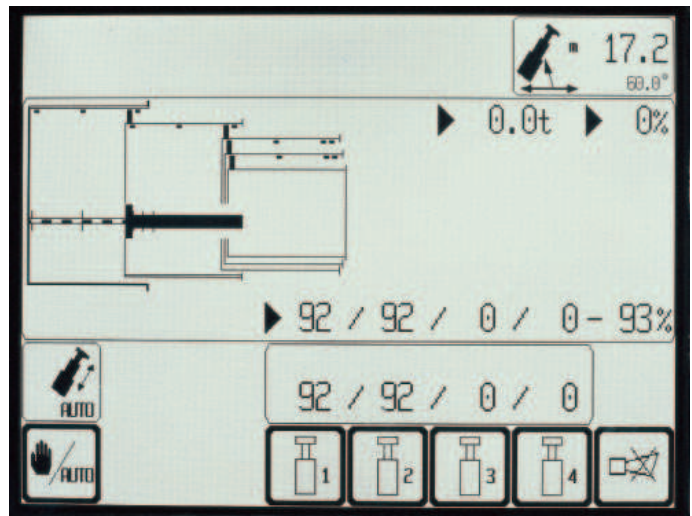
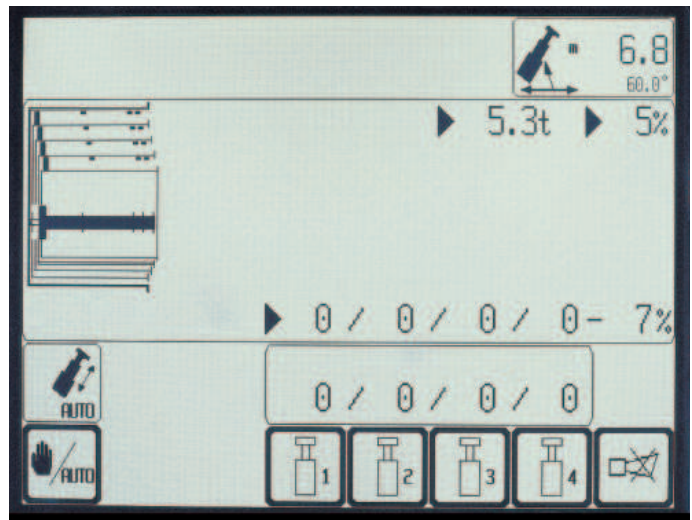

## The LICCON work area limitation system

- It relieves the crane operator, especially in situations where the handling of loads requires his full attention, by controlling the work area limits. Work areas can be restricted by buildings, bridges, roofs, high-tension lines, pipe lines or adjacent cranes. The automatic work area limitation system can easily be programmed. Four different limitation functions are practicable:
  - Height limitation of pulley head
  - Radius limitation
  - Slewing angle limitation
  - Limitation of edges

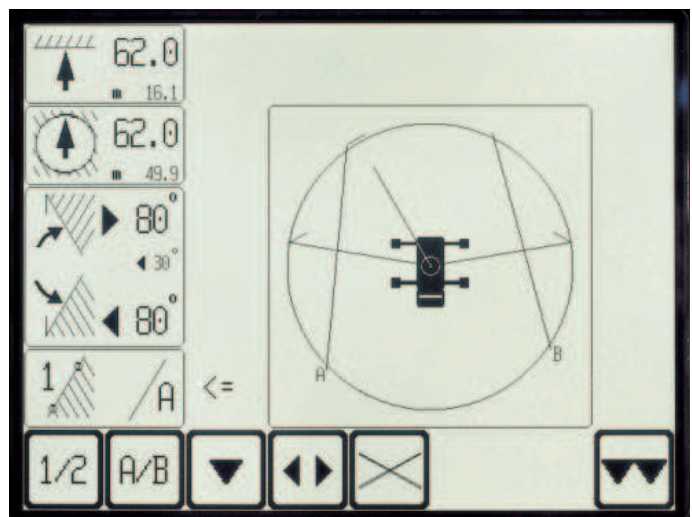

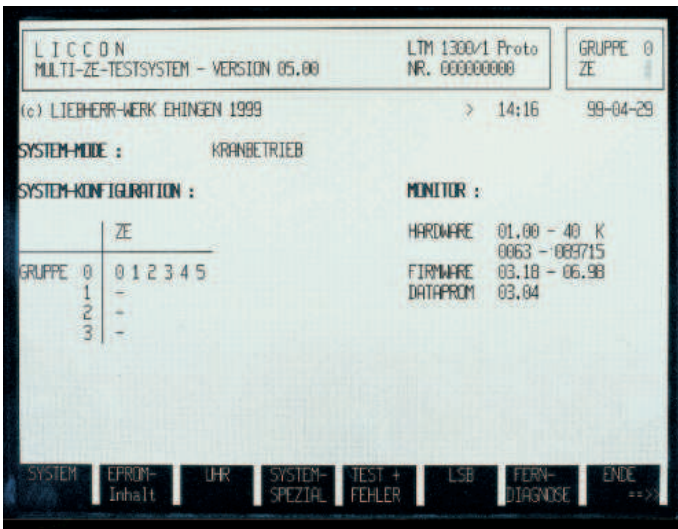

## The LICCON test system

- The test system assists the servicing personnel in quickly localizing errors of the sensor system without needing any further measuring instruments
- Convenient interactive functions permit the observation of all in- and outputs of the general system by different displays on the monitor even during crane operation. It equally visualizes the allocation of the individual sensors to the system as well as their function and the terminals concerned in the control cabinet
- The table of contents enables the display of the contents and the state of development of the program modules as well as the load charts on the monitor
- The service starts on the monitor, error detection becomes a matter of seconds



## The service and diagnostic system LiSSy

- This service and diagnostic system enables the data base assisted administration of the programmed errors in the crane control, including error text, description of cause of error as well as the measures for the error elimination
- The system provides the facility of a remote diagnostic analysis due to the rapid online access to the service documentation such as electric circuit diagram and workshop manual
- The possibility to memorize also the experiences of the crane users contributes to a progressive growth of the service and diagnostic system LiSSy to a data base of experience and knowledge

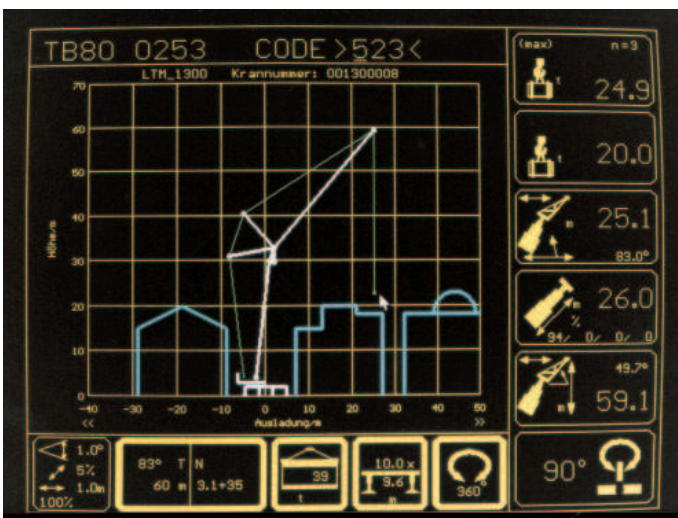

## The LICCON work planner

- The Liccon work planner consists of a software program of diskettes for planning, simulation and documentation of crane applications
- The 2D-planner allows to draw buildings, to write texts and to represent a crane model to scale including its entire motions within a fictional construction site
- The work planner enables the preparation of more transparent offers, it facilitates the briefing of the crane operators and it can be run on a laptop at the construction site



## Multivariable counterweight system

- Counterweight variants of 112.5, 87.5, 50, 37.5 and 12.5 t, thus a wide application spectrum
- Counterweight slabs with ideal transport dimensions
- Counterweight radius only 5.6 m
- Counterweight frame of modular set-up, consisting of basic frame and two winch packets, compact transport unit
- The counterweight basic slab (12.5 t) with the ballasting rams, the 6 counterweight slabs (12.5 t each) as well as the counterweight frame with winch 2 and 3 (optional) can be mounted as a complete unit
- 12.5 t basic counterweight can be carried during transport and can be mounted separately
- Winch 2 and winch 3 are mountable by pins and consequently are rapidly exchangeable if required, e.g. for the operation of a second LTM 1300/1
- Connection of the winches to the crane hydraulic system by rapid action couplings
- Standard auxiliary winch with transportable control panel for reeving of the hoist and luffing ropes

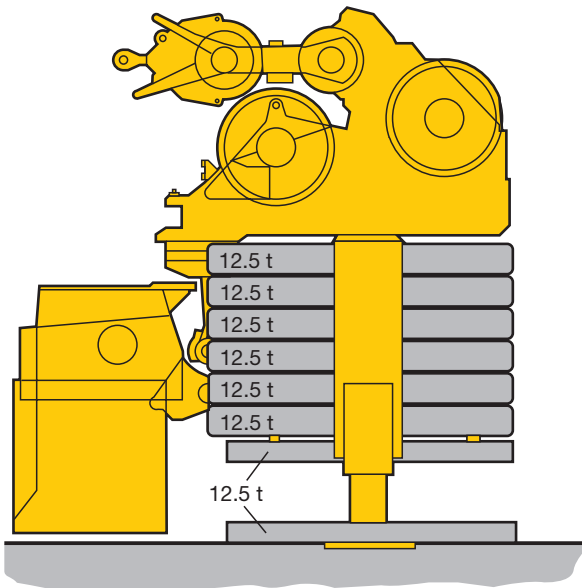

## Ballasting

- Stack the counterweight slabs on the carrier frame, the basic slab with the ballasting ram is the carrying slab
- Pick up, if required, the counterweight frame with winches 2 and 3 and lower and pin it to the fixing devices
- Depending on the counterweight required, stack the lateral counterweight slabs (a total of 2 slabs of 12.5 t each)
- Connect hydraulic couplings and remote control panel
- Extend ballasting rams and push counterweight frame upwards
- Swing superstructure into the longitudinal axis to the counterweight frame, lower the counterweight frame by retracting the ballasting rams and pin counterweight frame to superstructure
- Raise support
- Disconnect hydraulic couplings and remote control panel

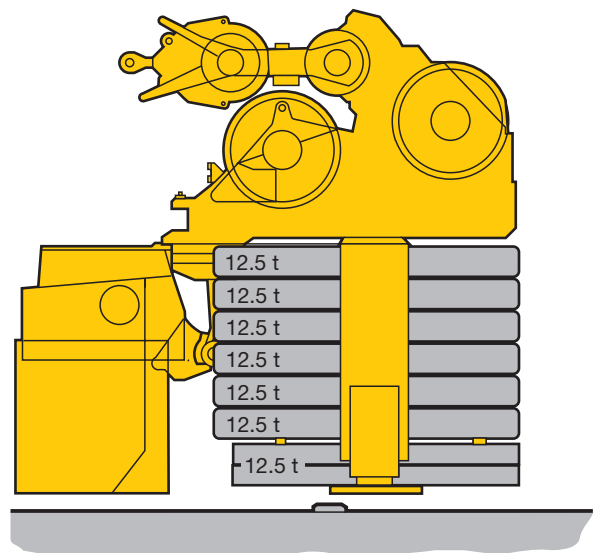
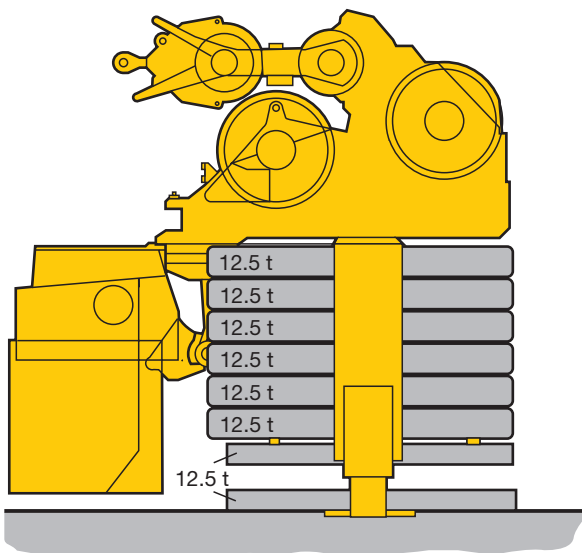

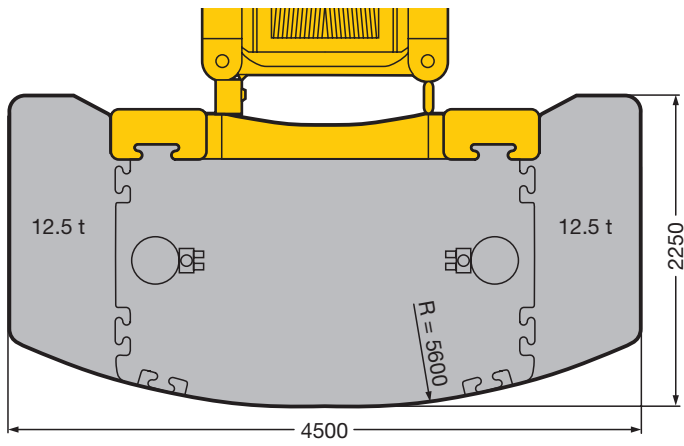

### Immediately operational with partial counterweight

- The basic counterweight of 12.5 t, the biparted swing-away jib as well as the telescopic boom guying system can be transported on the crane. Ballasting is performed without auxiliary crane within a few minutes.

#### Ballasting:

- Crane on outriggers, the basic counterweight placed on the carrier frame; after the telescopic boom has been raised, the superstructure is slewed into longitudinal direction to the basic counterweight
- Connect hydraulic couplings and remote control panel
- Extend ballasting rams entirely and pin basic counterweight to superstructure
- Retract ballasting rams entirely and raise support
- Disconnect hydraulic couplings and remote control panel

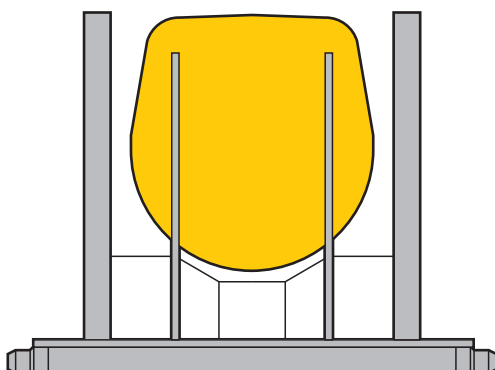
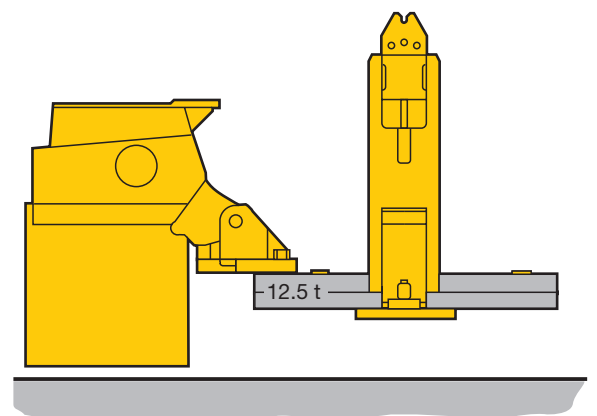
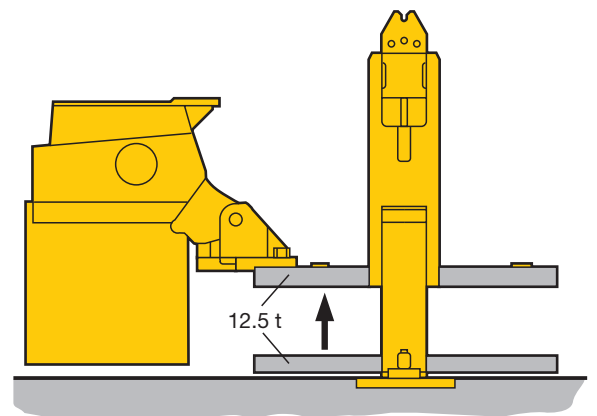
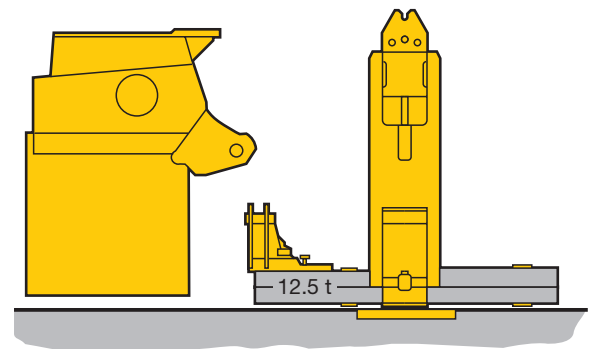

## Electric/electronic crane control with integrated safe load indicator

- Control of winches, slewing gear as well as luffing and telescoping motions via LICCON system (PLC control)
- Four working motions can be performed independent from one another
- Speeds of hoisting/lowering, slewing and luffing are preselectable in 5 steps
- Luffing speed controlled automatically dependent on the boom length
- Extremely short response times when initiating working motions

- Hoist gear and slewing gear are operating in a „closed oil circuit“. This ensures high-precision lifting, lowering and slewing of loads. Moreover, the potential energy generated during lowering is not transformed into heat but can be reemployed for a 2nd motion which results in the particular advantage of fuel saving and less thermal effects on the oil compared to an open circuit. No overheating of the oil.

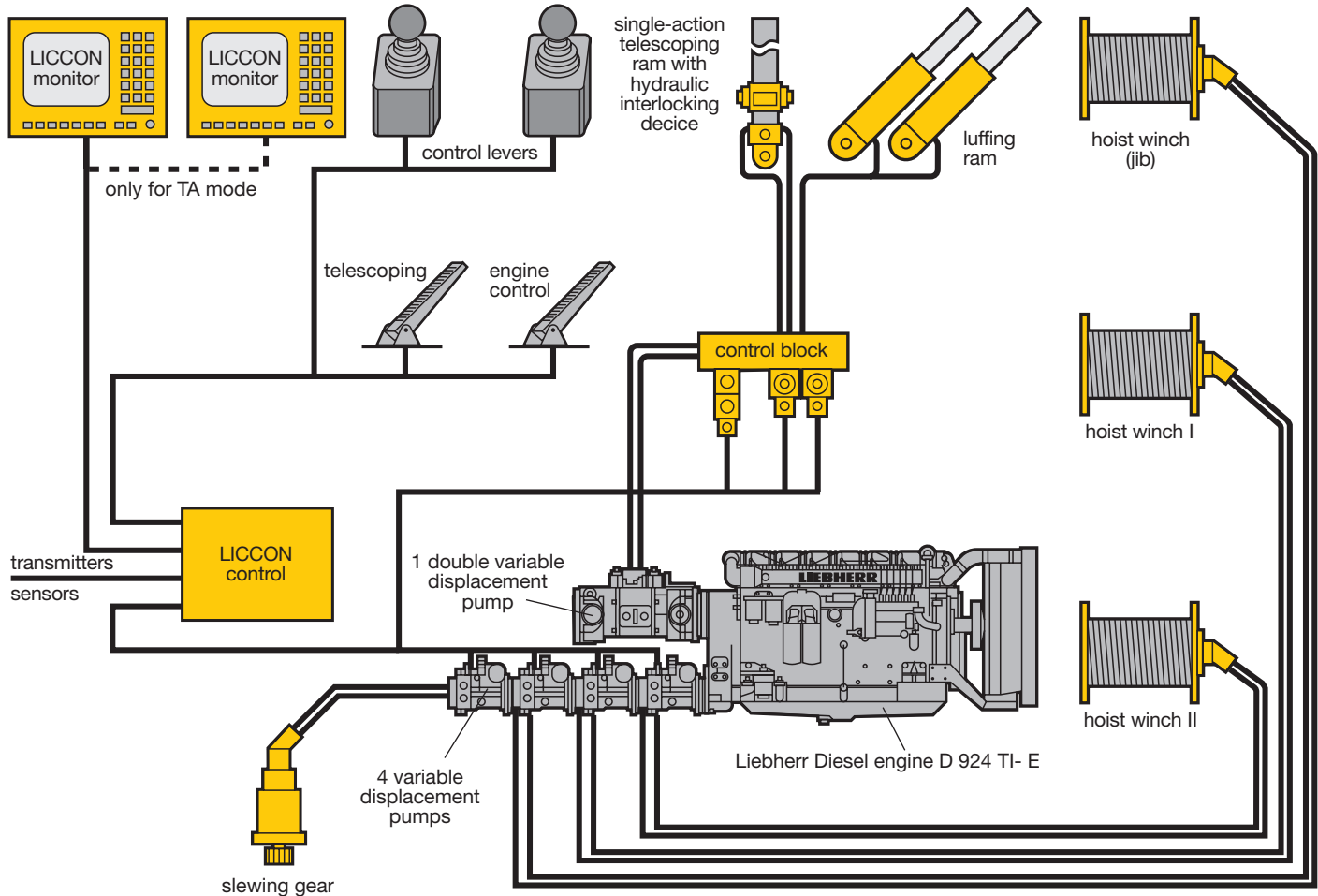

## Optional features contribute to an expansion of the application spectrum and increase comfort and safety

### On carrier

- Eddy-current-brake
- Outrigger control
- Rope box
- Air-conditioning system
- Radio preparation device
- Seat heating for driver's and co-driver's seat
- 3rd seat
- Shunting coupling
- Fog lamps
- Cassette radio set

### On crane superstructure

- Air-conditioning system
- Seat heating
- Mirror installation on hoist gear
- Work area limitation system
- Wind warning device – telescopic boom/swing-away jib
- Aircraft warning light
- Work projector 2 x 150 W on telescopic boom base section
- GSM module for remote diagnostic
- Radio preparation device
- Cassette radio set

Further optional features by request