

Mining Truck

T 282 B

Maximum Operating Weight 592 t / 652 ton
Payload Class 363 t / 400 ton



Photo shows optional equipment

LIEBHERR

Courtesy of Machine.Market

The T 282 B

The Liebherr T 282 B combines a high horsepower diesel engine with an extremely efficient Liebherr-Siemens AC drive system to maximize productivity and reduce downtime. The AC alternator and traction motors are virtually maintenance free, since their rotors are the only moving parts. The drive system is controlled via electronic solid state controllers, which are small, extremely fast and have no moving components to wear out. Lighter than both a DC drive system or a mechanical drive train, an AC drive system allows for greater payload to empty vehicle weight ratios, faster acceleration and higher travel speeds. This results in faster cycle times and lower cost per ton productivity.



Photo shows optional equipment and paint





Front Wheel and Brakes

When stopping, electric retarding will slow the truck to a virtual stand still, at which time the service brakes are automatically applied by the control system while the operator is applying the retarder pedal. The service brakes are also automatically applied by the anti roll back function at very low speeds.



AC Drive Performance

The Liebherr-Siemens AC drive system has been tested and proven extensively in mining applications and other industries. It is dependable, easy to service and maintain and offers a long life expectancy. When coupled to a high horsepower diesel engine, the continuous acceleration and retard performance without having to shift gears provides the mine operator with fuel efficiency and high productivity to reduce cost per ton.

Main Features

- Steering support – the system will automatically send more power to the outside rear wheel or reduce power to the inside rear wheel to help reduce tire wear.
- Anti Rollback – When facing uphill with the travel lever in forward or when facing downhill with the travel lever in reverse, the truck will not roll down hill when propulsion is started.
- Two speed over speed – Automatically limits the truck speed to the pre-set limit. One setting for a loaded truck and one setting for an empty truck. Overrides the cruise control setting
- Cruise control – Two modes are available, retard only cruise and full cruise.
- Slip / Slide control – Propel power as well as retarding power are automatically corrected individually for each set of rear wheels to minimize wheel spin or sliding in adverse road conditions.

SIBAS Monitoring Program

Siemens electronics provide:

- Real time information during operation can be displayed for the operator or be remotely sent to a centralized management system.
- Snap shots taken during fault events are easily retrievable.
- Load Boxing, to test-check the electric travel drive system at full diesel engine power, while the truck is parked.

AC drive main components

1. Diesel engine
2. Alternator and rectifier
3. Control box with integrated main blower
4. Traction motors and planetary gears
5. Grid box mounted on the deck

Rear Brakes

The dry disc service brakes on the front and rear wheels are used to bring the truck to a safe stop and are designed and tested to comply with ISO 3450.

The rear service brakes are cooled by forced air, eliminating the need for an additional hydraulic cooling and circulation system.

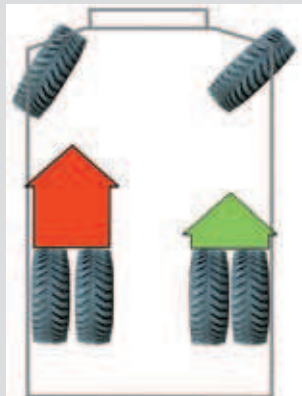

Differential Wheel Torque Control

When traveling through a curve, the drive system will automatically adjust the torque and speed of the rear traction motors in order to maximize traction and minimize tire wear during low speed handling.

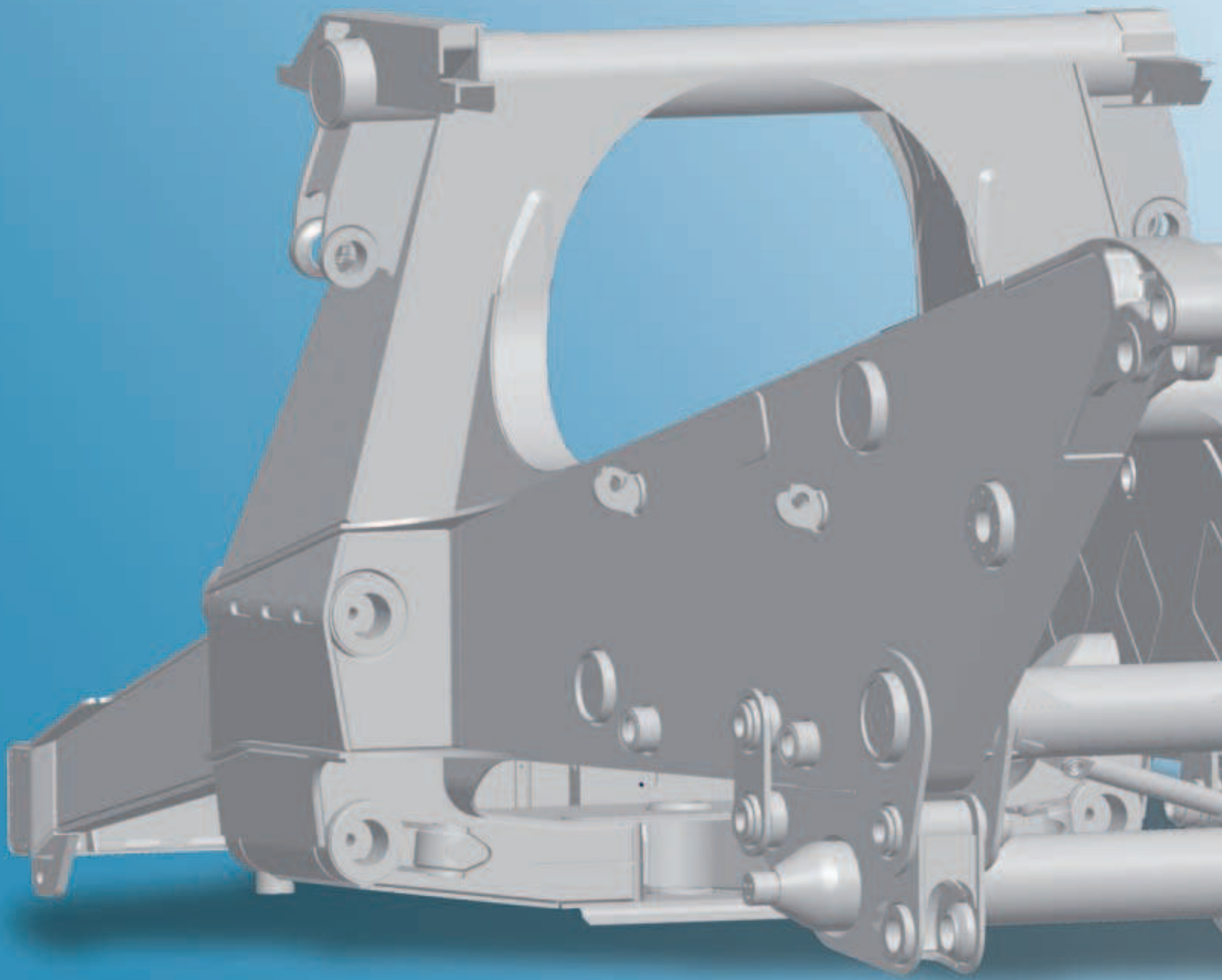

Front Suspension

The T 282 B features a “Double A-frame” Front Suspension. This unique geometry allows the tire contact point to move up and down in a straight line during travel and loading.

Immediate and accurate payload weighing is possible since there are no side loads on the struts.

Due to the A-frame’s lever action design there is longer vertical wheel travel than strut travel, resulting in reduced tire deflection.

Chassis

Utilizing the latest in software and durability information, Liebherr is able to focus on a more modernized approach to equipment design by combining advanced analysis and test validation to produce a product which is truly “fit for purpose“.

Engineered to be strong, durable, rugged and yet lightweight, the main frame of the Liebherr T 282 B continues to evolve while maximizing the payload to empty vehicle weight ratio ensuring greater productivity and efficiency, reducing the cost per ton of the mining operation.

Durable Steel Structure

- Hollow box frame rails with internal stiffeners fully welded inside and out.
- Torque tube connections to absorb warping stresses in the frame rails.
- Independent Cross Carriage transfers forces from rear axle and dump cylinders directly into the frame rails.
- “Stress flow” designed cast steel components are used in high stress areas.

Quality

- High strength steel is used throughout the main frame
- Ultrasonic inspection aligned with AWS D1.1
- Close attention to weld fatigue details
- Designed to IIW (International Institute of Welding) weld fatigue guidelines.



Rear Suspension

The unique Rear Wheel Suspension replaces the traditional nose cone with two Drag Links and a triangular Rear Control Arm. All forces from the rear axle are transferred into the truck frame in straight lines.

Two Suspension Struts transfer all loads from the frame via the top of the axle box directly into the wheels. This allows for a shorter, lighter frame and does not create any torque within the axle box, saving weight.



Operator Cab

Featuring integrated ROPS and a fully insulated double shell construction, the operator cabin of the Liebherr T 282 B is ergonomically designed to allow excellent visibility of the working environment as well as maximizing operator comfort and safety.

Visibility is further enhanced with the aid of mirrors and optional closed circuit television to assist the operator in safely operating the truck when in close proximity to people and smaller equipment.



Operator Comfort

The Liebherr T 282 B features a comfortable and safe environment for the operator enabling efficient equipment control, to achieve excellent performance.

Operator Feedback

Real time digital and analog information is displayed, on a LCD monitor including;

- Vital machine information
- Secondary information and alarms
- Fault event messages.

Three Communications Ports for information sent and received from;

- Engine Control System
- Drive System
- Payload System

Safety

- Integrated ROPS (Roll Over Protective Structure) for the cab.
- Fully insulated double shell construction.
- Two ladders with dual hand rails leading to the deck with an optional diagonal stairway for safe operator access.
- Recessed bolt heads and toe kick plates.

Comfort

- Six-way adjustable air suspended driver seat with double lumbar support, with a full size trainer seat.
- Spacious interior with plenty of storage space.
- Insulated against sounds, vibration and dust.
- Heavy duty heater and air conditioner to maintain a pleasant environment for the operator.



Access and Egress

Operator comfort and safety is paramount to having a productive fleet of equipment. There are a number of options available in regards to access and egress ladders designed to ensure three point contact with the equipment and to reduce the stresses and strains on operators and maintenance personnel when climbing on and off the equipment.



Deck

The large and spacious deck of the Liebherr T 282 B allows for additional installation of optional safety equipment such as fire suppression systems or mine communication systems. The standard truck is fitted with two means of egress from the deck.



Maintenance Friendly

The Liebherr-Siemens AC drive system of the T 282 B has few service requirements, reducing downtime ensuring maximum productivity of the truck. Scheduled servicing can be carried out in a safe manner due to the spacious design and excellent ground level access to key service locations.



Safety and Accessibility

Safety is a key focus in the design of the Liebherr T 282 B. Liebherr recognizes that the equipment will be more productive if the operator and the service personnel feel safe in their daily working environment. Some of these safety features are highlighted below.

Operational Safety

- Automatic brake application to bring the truck to a final stop when depressing the retard pedal.
- High capacity retard capability with a virtually immediate response time.
- Full retarding capability with a dead engine.
- Anti rollback in forward and reverse.
- Slip / Slide control both uphill and in downhill modes.

Fire Prevention By Design

- Fuel and hydraulic lines are separated from electrical lines and heat sources
- Critical hydraulic hose are encased in non permeable hose sleeves
- Turbochargers and exhaust piping are shielded by insulated pre shaped covers and side exhausts are standard.
- Access ladders are fabricated with solid steel backs and fire aprons are fitted between the ladders and the engine compartment.



Legend:

- A Spacious, high visibility operator cabin with integrated ROPS and low sound levels for the operator
- B Optional engine air filter platforms for better maintenance access
- C Optional drop down access ladder for safer access and egress
- D Diagonal access ladder with dual hand rails to maintain a three point contact at all times
- E High intensity discharge headlights for optimum visibility
- F Optional fire suppression systems
- G Optional off driver side and rear view closed circuit telemetry for increased visibility

Accessibility

- Ladders to access the engine and alternator are located on both sides of the main chassis with excellent walk around access via service platforms.
- Engine and hydraulic system filters accessible either from the ground level or from the catwalks around the engine installation.
- Drop down door and steps to access the rear axle box's electrical and mechanical components.
- Tie off points where access is limited.



Service Points

- The automatic lubrication system reduces downtime.
- Sampling points located at or near ground level.
- Centralized service station located conveniently at ground level for fast and efficient refilling.
- Air cleaner restriction gauges mounted in the cab for optimum visibility.

Technical Data



Engine

Model _____	MTU DD 20V4000
Gross horsepower @ 1800 rpm _____	2,722 kW (3,650 hp)
No. of cylinders _____	20
Displacement _____	90 L (5,490 in ³)
Wet weight _____	10,480 kg (23,100 lbs)
Crankcase _____	390 L (103 gal)
Cooling system _____	758 L (200 gal)

Model _____	Cummins QSK 78
Gross horsepower @ 1900 rpm _____	2,610 kW (3,500 hp)
No. of cylinders _____	18
Displacement _____	78 L (4,735 in ³)
Wet weight _____	11,300 kg (24,912 lbs)
Crankcase _____	281 L (74 gal)
Cooling system _____	721 L (191 gal)
Fan clutch _____	Rockford variable speed, temperature controlled
Air cleaners _____	Two units with 2 elements per unit with restriction gauges in the cab
Radiator _____	Mesabi
Starter _____	Electric
Roll out power module _____	Radiator, engine and alternator, mounted on roll out sub frame
Batteries _____	6 x 12 Volt, (3 series of 2), 1200 CCA each at -18° C (0° F), 1475 CCA at 0° C (32° F)



Electric Drive System

Manufacturer _____	Siemens-Liebherr
Alternator _____	AC brushless, direct drive with top mounted rectifier
Traction motors _____	AC induction motors
Gear ratio _____	Standard 37.33 to 1 Optional 43.7 to 1
Max speed _____	64 km/h / 40 mph
Cooling fan _____	AC drive, two impeller radial fan, control box mounted.



Tires

Rims _____	41 inch wide with 5.5 x 5 inch flanges
Tires _____	Michelin 56/80 R63 or Bridgestone 59/80 R63



Suspensions

Front suspension _____	Double A-frame with inclined king pin design pivot and spindle
Rear suspension _____	Three bar linkage comprised of triangular upper link plus two bottom drag links
Suspension struts _____	Nitrogen over oil with integral damping.



Braking Systems

Electric dynamic retard with continuously rated, fan forced air over stainless steel resistor grids with a dry disc secondary braking system	
Electric dynamic retard _____	Max: 4,480 kW (6,030 hp)
Extended speed range _____	Full retarding down to 0.8 km/h (0.5 mph). Automatic brake blending with service brakes down to zero.
Cruise control _____	Operator adjustable and will auto retard truck on downhill grade
Two speed over speed _____	Automatic speed settings for empty and loaded truck adjustable for site requirements
Slip slide traction control _____	Computer controlled, propel and retard, forward and reverse, fully independent left and right.
Service brakes front _____	Single disc, wheel speed, five calipers per wheel
Service brakes rear _____	Dual discs per side, one caliper per disc, armature speed
Hydraulic accumulators _____	2 x 7.6 L (2 x 2 gal), Separate accumulator for front and rear axle.
Park brakes _____	Spring applied, pressure released, one caliper per each rear disc.
Filtration _____	Cleanliness level ISO 18/16/13



Steering

Ackermann center point lever system. Full hydraulic power steering with accumulator safety backup. Fully separate from dump hydraulic system. Two double acting hydraulic cylinders.	
Hydraulic accumulator _____	174 L (46 gal) SAE J53
Filtration _____	Cleanliness level ISO 18/16/13
Turning radius (SAE) – Tire centerline* _____	18.6 m (61 ft)
Vehicle clearance Radius _____	Depends on options fitted
* This is a theoretical calculation and depends on the ground surface, the strut length and tie rod length	



Dump System

Two double stage, double acting hoist cylinders with inter stage and end cushioning in both directions. Electronic joystick with full modulating control in both extend and retract.	
Dump angle _____	45°
Cycle times _____	Raise - 34 sec Power Down - 22 sec
Remote dump _____	Quick disconnects for external power dumping (buddy dump) accessible from ground level
Filtration _____	Cleanliness level ISO 18/16/13



Body

Two double stage, double acting hoist cylinders with inter stage and end cushioning in both directions. Electronic joystick with full modulating control in both extend and retract.	
--	--

Technical Data



Frame

Design	Closed box structure with multiple torque tube cross members, internal stiffeners and integrated front bumper. Steel castings are used in stress concentration areas.
Welding	Frame girders welded inside and out with ultrasonic inspection aligned with AWS D1.1



Operator Cab

Deluxe operator cabin with integrated ROPS and double wall design for optimum insulation. Fully adjustable air suspension operator seat with double lumbar support and full size second seat for training requirements. Operator comfort controls include a tilt and telescoping steering wheel, heater, defroster and standard AC. Real time vital truck information is easily displayed to the operator and also recorded for download.



Sound

Designed to meet OSHA and MSHA occupational noise criteria for truck operator weighted sound exposure



Dimensions

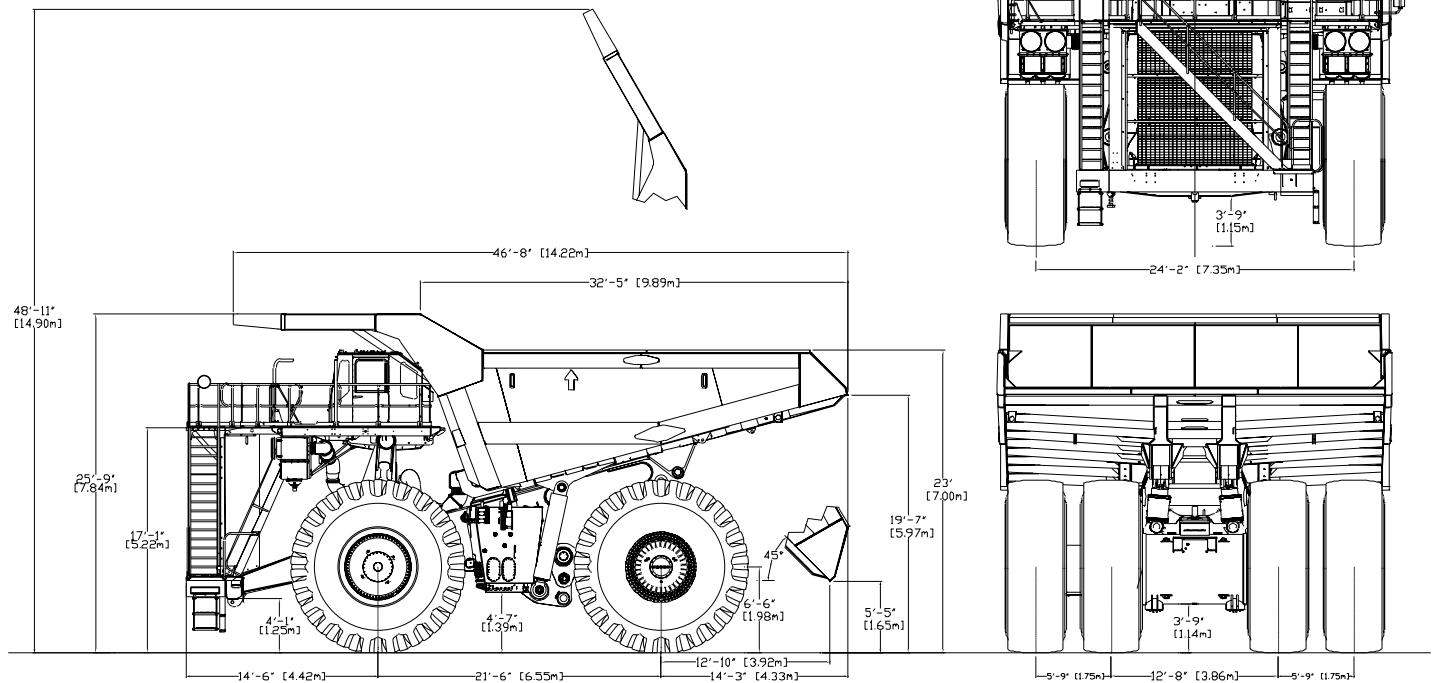

Note: All Measurements assuming unloaded using 56/80R63 tires



Weights

Payload class	363 t / 400 ton
Max operating weight	592 t / 652.5 ton
Chassis weight *	189 t / 208 ton
Body weight	Custom for each mine site
Frame capacity **	404 t / 445 ton
Weight distribution	Empty - front 46 % / Rear 54 % Loaded - front 33 % / rear 67 %

* depends on options fitted

** total weight of body and payload, subject to chassis weight.



Fluid Capacities

Fuel tank	4,732 L / 1,250 gal
Hydraulic dump circuit	
- Tank	1,302 L / 344 gal
- System	1,514 L / 400 gal
Hydraulic brake and steering	
- Tank	924 L / 244 gal
- System	1,060 L / 280 gal
Final drives, each (2)	280 L / 74 gal
Front wheels, each (2)	60 L / 16 gal
Grease tank	90 kg / 200 lbs

Performance Curves

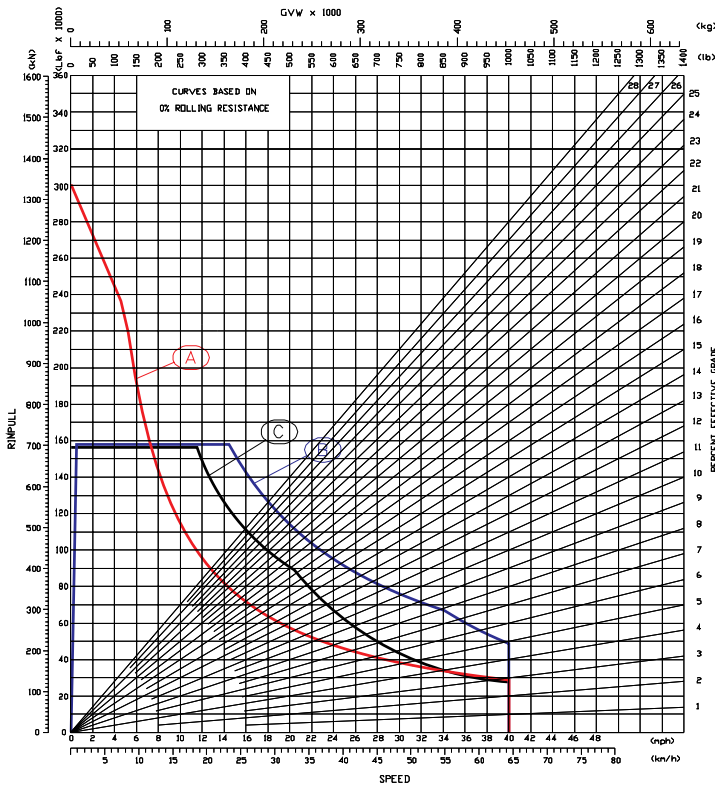

Performance Chart Parameters

Gross power _____ 2,722 kW (3,650 hp)
 Net power _____ 2,558 kW (3,430 hp)
 Tire size _____ 56/80 R63
 Gear ratio _____ 37.33 to 1
 Reference curves _____ A: Propulsion
 _____ B: Retard
 _____ C: Trolley (see note 1)

Note 1. Trolley performance shown is augmented with engine power if the line voltage is below 2600 VDC.

The propulsion curve is calculated using net horsepower therefore site specific and climatic variables will have an effect on the parasitic losses.

Optional performance charts are available on request.

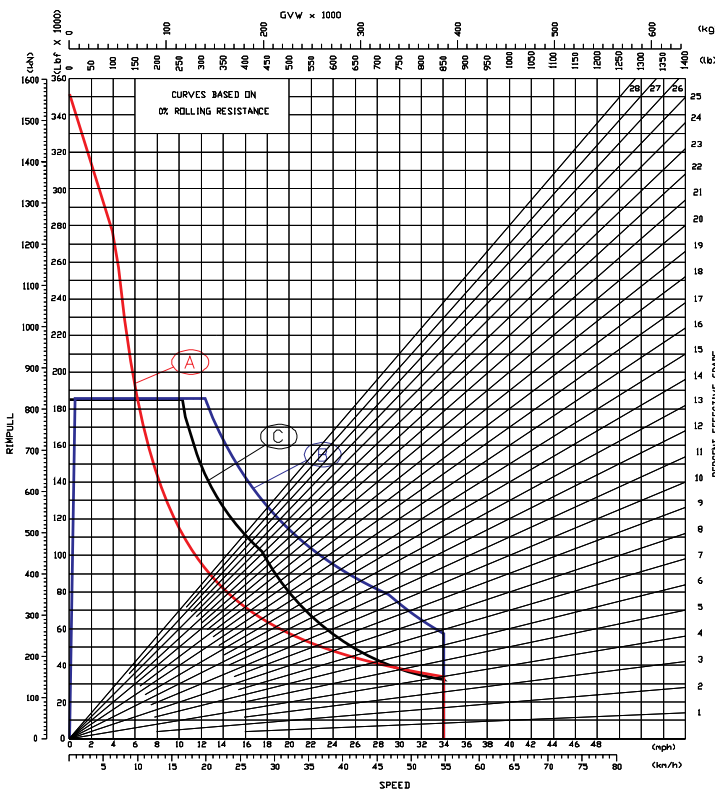

Performance Chart Parameters

Gross power _____ 2,722 kW (3,650 hp)
 Net power _____ 2,558 kW (3,430 hp)
 Tire size _____ 56/80 R63
 Gear ratio _____ 43.7 to 1
 Reference curves _____ A: Propulsion
 _____ B: Retard
 _____ C: Trolley (see note 1)

Note 1. Trolley performance shown is augmented with engine power if the line voltage is below 2600 VDC.

The propulsion curve is calculated using net horsepower therefore site specific and climatic variables will have an effect on the parasitic losses.

Optional performance charts are available on request.

Standard/Optional Equipment



Truck Standard Equipment

- Automatic air cleaner dust ejectors
- Side exhaust with insulated exhaust pipes
- Mufflers
- L&M (Mesabi) radiator
- Large diameter, low rpm engine fan
- Rockford fan clutch
- Electric starter
- 6 x HD 12 V Batteries
- Engine shutdown and disconnect at ground level
- Bolted rims on front and rear
- Spring applied pressure released park brake
- Accumulator backup on steering and hydraulic brake system
- Dual access ladders plus diagonal ladder
- Catwalks and platforms on both sides of the engine
- Automatic lubrication system
- Centralized service station (driver side)
- Back up warning alarm
- Service lights in engine compartment and axle box
- Ladder access lights
- Auxiliary dump, brake and steering connectors
- Second fuel gauge on centralized service station
- Sight gauge on hydraulic tank
- Sight gauge on radiator header tank
- Mud flaps on both sides of hydraulic and fuel tanks
- Rear wheel rock ejectors
- Hand held fire extinguishers (2) mine to install
- External digital payload system display on left and right
- Liebherr white standard color for chassis.
- Integrated ROPS
- Fully adjustable operator seat with air suspension
- Passenger seat with mechanical suspension
- 2 point seat belt
- Tempered front cab glass with laminated safety glass on other windows
- Power windows
- Dual blade windshield wipers, electric
- Side mirrors, left and right
- Tilt and telescopic steering wheel with horn
- 3 x sun visors
- Pressurized cab with filtered heater and defroster and standard Red Dot AC System
- 12 VDC and 115VAC power supply in cab
- Computerized dash display
- Air cleaner restriction indicators
- 37.33 to 1 gear ratio



Truck Optional Equipment

- Air Starter
- Gear ratio of 43.7 to 1
- Cold climate kits
- Retractable access ladder
- Special language decals
- Additional headlights
- Fog lights
- Hub-odometer
- Additional mud flaps
- Fire suppression systems
- Heated dump body
- Body liner packages
- Tailgate for coal body
- Trolley drive
- Custom paint specification
- Side and rear video camera
- Air cleaner access platforms
- Belly pan skid plates
- Air ride passenger seat

Please contact your local representative for further information.

The Liebherr Group of Companies

Wide product range

The Liebherr Group is one of the largest earthmoving and construction equipment manufacturers in the world. Liebherr's high-value products and services enjoy a high reputation in many other fields, too. The wide range includes domestic appliances, aerospace and transportation systems, machine tools and maritime cranes.

Exceptional customer benefit

Every product line provides a complete range of models in many different versions. With both its technical excellence and acknowledged quality, Liebherr products offer a maximum of customer benefits in practical application.

State-of-the-art technology

To provide consistent, top quality products, Liebherr attaches great importance to each product area, its components and core technologies. Important modules and components are developed and manufactured in-house, for instance the entire drive and control technology for construction equipment.

Worldwide and independent

Hans Liebherr founded the Liebherr family company in 1949. Since that time, the enterprise has steadily grown to a Group of 100 companies with over 26,000 employees located on all continents. The corporate headquarters of the Group is Liebherr-International AG in Bulle, Switzerland. The Liebherr family is the sole owner of the company.

www.liebherr.com



Printed in Germany by Eberl BK-RP LME 10100384-2-04.07

Subject to technical modifications.

Liebherr Mining Equipment Co.
4100 Chestnut Avenue, Newport News, VA 23607, USA
☎ +1 757 245 5251, Fax +1 757 928-8755
www.liebherr.com, E-Mail: info.lme@liebherr.com

Courtesy of Machine.Market