

# Casing oscillators



# LIEBHERR

Courtesy of Machine.Market

## Technical data

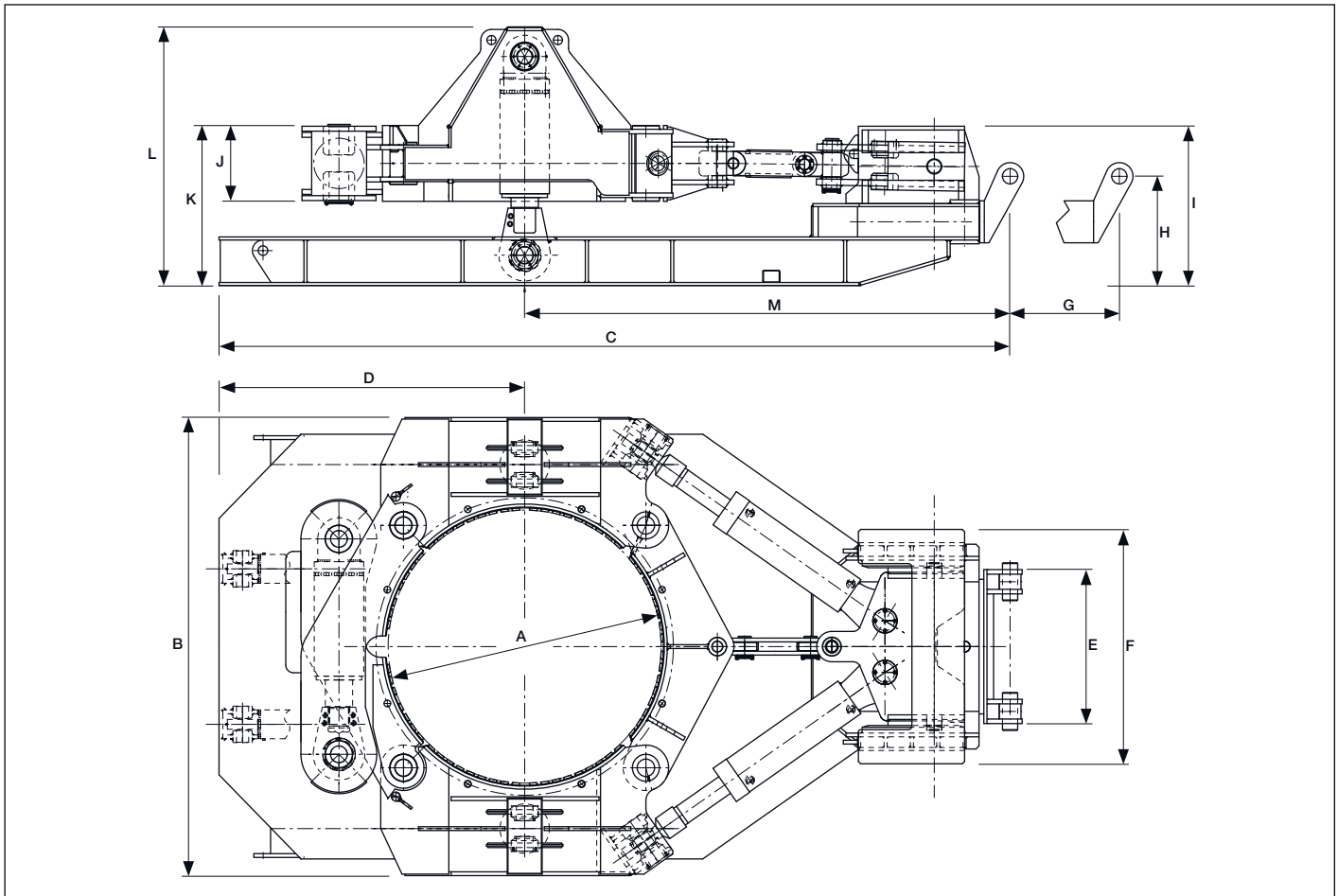

		VRM 118+120 KL	VRM 150 KL	VRM 180 KL	VRM 200 KL	VRM 250 KL
<b>Stroke</b>	mm	400	450	450	450	450
<b>Lifting force</b>	kN	1000	1790	2256	2300	2950
<b>Clamping force</b>	kN	1000	1560	1814	1850	2570
<b>Rotation angle</b>	°	22	22	22	22	20
<b>Torque</b>	kNm	1070	1950	2380	2700	3000
<b>Operating pressure</b>	bar	270	270	270	300	300
<b>Travel of casing</b>	mm	250	285	345	350	436
<b>Weight</b>	t	7	11	16	17	25
<b>A Max. casing diameter</b>	mm	1200	1500	1800	2000	2500
<b>B Width of machine</b>	mm	2050	2500	3020	3220	4000
<b>C Length of machine</b>	mm	3270	4070	5300	5560	5980
<b>D Min. spacing</b>	mm	1000	1420	2015	2015	2265
<b>E Width of cradle</b>	mm	800	800	800	800	800
<b>F Width of machine excavator side</b>	mm	100	1250	1350	1400	1800
<b>G Cradle path</b>	mm	400	450	450	450	450
<b>H Axis excavator side</b>	mm	630	630	630	630	630
<b>I Height of machine excavator side</b>	mm	1000	1100	1050	1050	1070
<b>J Height of cradle guide</b>	mm	400	500	500	500	700
<b>K Height from ground to top of cradle</b>	mm	810	1020	1050	1050	1000
<b>L Height of machine</b>	mm	1485	1600	1705	1685	1855
<b>M Length attachment-center pile</b>	mm	2270	2800	3200	3545	3715

## General remarks



VRM KL in operation

The short hydraulic casing oscillators have been designed in accordance with the latest technical know-how. The Hydraulic Casing Oscillators KL are perfectly suited for mounting Liebherr Piling and Drilling Rigs, series LRB as well as LB. Extremely sturdy construction guarantees cost-efficient use on site. By means of exact statical calculations in conjunction with higher quality material, an optimum conformity of loads, weight and material strength is achieved. The internal welding stresses – difficult to determine for static calculations, which would affect the construction considerably – are eliminated by means of stress relieving prior to machining. A prominent feature of the equipment is the clamping collar consisting of five links operating on the boring implement. The individual links surround the casing like a chain so that a consistent surface pressure is exerted on the casing circumference. In addition, the large height of the collar (340-500 mm resp.) prevent any damage to the casing. By means of easily exchangeable reducer pieces the oscillator can be converted, within a few minutes, to a smaller casing diameter. The collar opens uniformly

and enables unproblematic insertion of the casing with the cutting shoe. Attachment at the excavator itself is torque rigid and guarantees the transmission of the full rotary movement to the casing if the excavator is firmly situated.

The design and construction of the casing oscillator is based on the experience of many years of cooperation with companies specializing in pile foundations. In view of the high costs which would result from a breakdown of the equipment on site, great emphasis has been put on exceptionally sturdy construction.

### Accessories

1. Inserts
2. Lower casing clamp
3. Lifting device
4. Wireless remote control
5. Power pack

