

LIFTMOORE 3612X 9-15

12,000 FT.-LB. MOMENT RATING
3,600 LB. MAXIMUM CAPACITY

- With it's 12,000 Ft.-Lb. Moment rating and 3,600 Lb. Maximum load, the 3612 provides the necessary capacity for many of your field service requirements.

- The Model 3612X 9-15 features include full hydraulic power extension from 9 ft to 15 ft., Power Boom Elevation, continuous unlimited power rotation as well as an efficient 2.7 HP planetary gear hoisting winch.

This unit is designed and built to give the operator precise and efficient control of the load at all times using the standard wired controller.

- An Optional wireless control give's the operator control of the crane with complete freedom of movement.

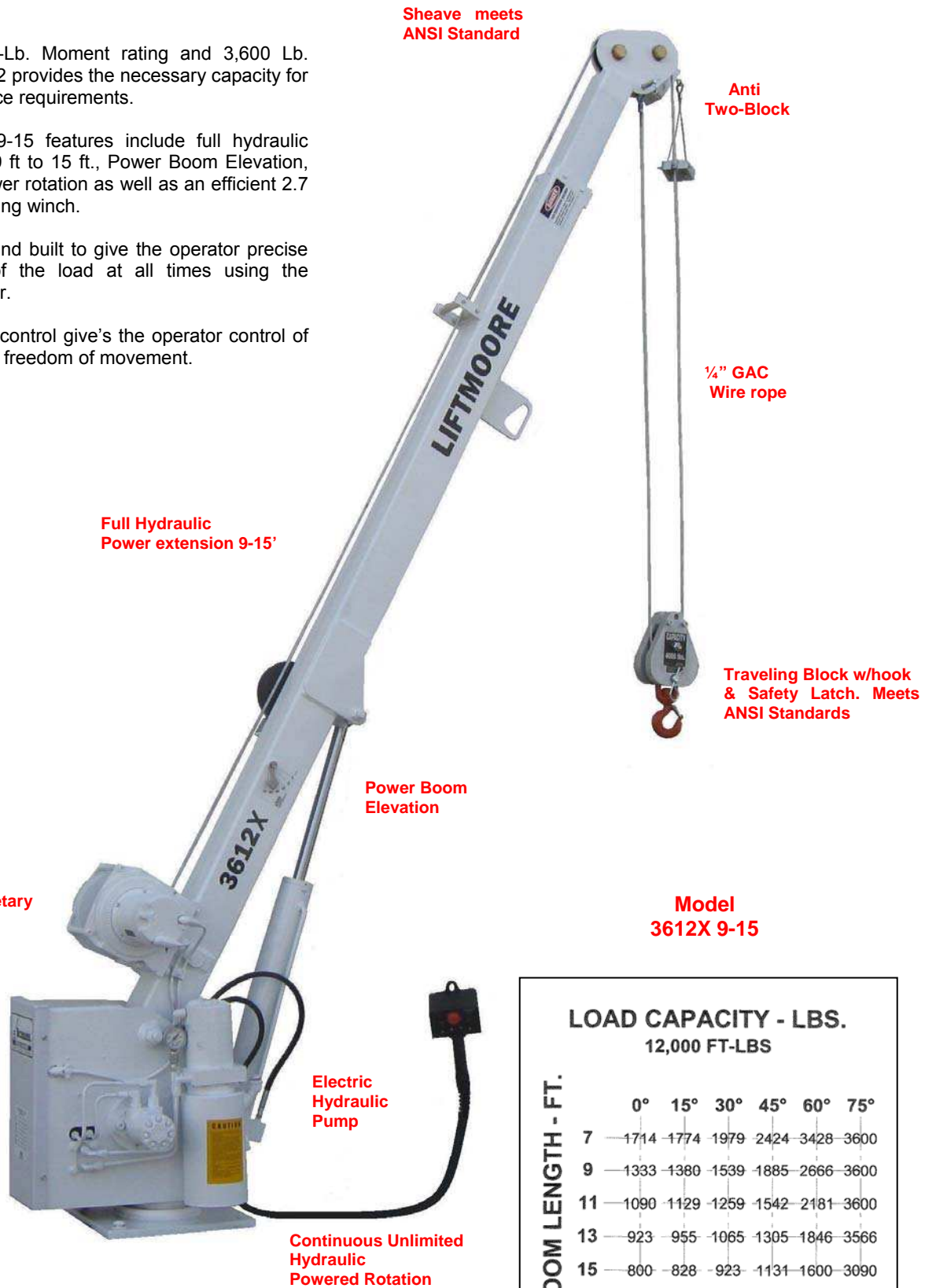

Sheave meets ANSI Standard

Anti Two-Block

1/4" GAC Wire rope

Traveling Block w/hook & Safety Latch. Meets ANSI Standards

Full Hydraulic Power extension 9-15'

Power Boom Elevation

2.7 HP Planetary Gear Winch

Model 3612X 9-15

Rotates on Tapered Roller Bearings

Electric Hydraulic Pump

Continuous Unlimited Hydraulic Powered Rotation

LOAD CAPACITY - LBS.		12,000 FT.-LBS					
BOOM LENGTH - FT.	ANGLE						
	0°	15°	30°	45°	60°	75°	
7	1714	1774	1979	2424	3428	3600	
9	1333	1380	1539	1885	2666	3600	
11	1090	1129	1259	1542	2181	3600	
13	923	955	1065	1305	1846	3566	
15	800	828	923	1131	1600	3090	



HOUSTON, TEXAS
FAX: (800) 824-5559 (USA & Canada)
FAX: (713) 688-6324
PHONE: (713) 688-5533
www.liftmoore.com



3612X 9-15 SPECIFICATIONS

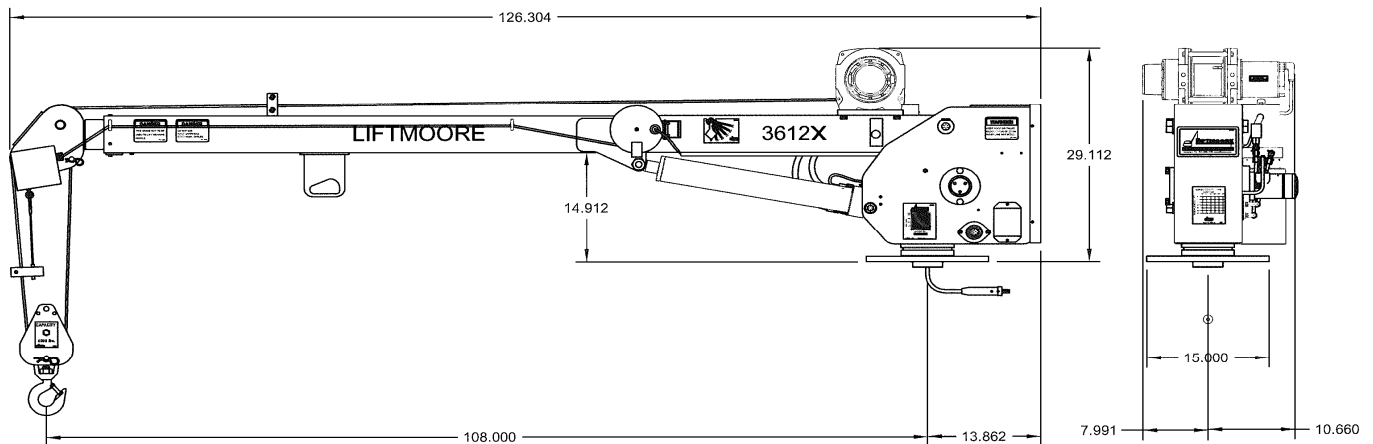

MOMENT RATING: 12,000 Ft.-Lbs.

HOIST WINCH: The hoist winch has a planetary gear drive for best possible efficiency. A 2.7 HP permanent magnet electric motor powers the winch. Single line capacity of the winch is 2000 Lbs. Load is controlled by a load apportioned mechanical brake located in the winch drum. Ratio between winch drum and wire rope meets ANSI B30.5 requirements.

First layer performance of the winch is as follows:

Load-Lbs	Hook Speed-Ft/ Min.	Electrical-Amps @ 12VDC
1000	13.1	64
2000	11.9	115

Note: Two part line required for loads above 2000 Lbs.

WIRE ROPE and SHEAVES: The crane is supplied with 62 Ft. of ¼ in. galvanized aircraft cable. Minimum breaking strength of the rope is 7000 lbs. The wire rope is outside of the boom and visible for operator's continual inspection. A traveling block for easy two-part hookup is included. All sheaves meet ANSI requirements.

BOOM ELEVATION: The boom is capable of moving from -5 to +75 Degrees. A double acting cylinder with an integral counterbalance valve elevates the boom. The counterbalance valve has two important functions. This valve holds the cylinder in the event of hose failure and it controls the rate of boom decent.

BOOM EXTENSION: The boom extends under hydraulic power from 9 ft. to 15 ft. The double acting cylinder incorporates an integrally mounted counterbalance valve.

HYDRAULIC SYSTEM: A hydraulic pump driven by a 12 volt D.C. series wound electric motor powers the crane's rotation, elevation and extension functions. Pump is a gear type with a 1.3 GPM capacity at 500 PSI. Control of the hydraulic functions is through four way spring centered solenoid activated valves. Valves have manual override capability and are mounted on a manifold for easy access.

ROTATION SYSTEM: The hydraulic powered rotation is driven by a low speed, high torque hydraulic motor. The crane rotates 360 degrees continuously without limit on two 3.75" ID Tapered roller bearings.

REMOTE PENDANT CONTROL: An 18-Ft. long remote pendant is provided for control of each powered function. The Pendant control is removable from the crane to prevent unauthorized use of the crane. An E-Stop is included for emergency shutdown of all crane power as required by OSHA. **Optional** Wireless control is available.

LOAD SENSOR: A load-limiting sensor is supplied as standard. This sensor will shut down hoist up, boom out & boom down when an overload is detected. The sensor will reset after the load is lowered.

ANTI TWO-BLOCK: Prevents extending the boom against the travel block and breaking the cable.

POWER SOURCE: Crane is powered by the truck's 12 volt DC system. A second battery is required to keep the voltage as high as possible and should be installed in parallel with the vehicle's battery. A Group 31 "DEEP CYCLE" battery is recommended. 25 Ft of #1 battery cable with quick disconnect is included along with a 3-ft ground wire, 150amp circuit breaker and master cut off switch.

MOUNTING: An 11,000 Lb or larger GVWR chassis is recommended. Four 0.50" X 2.5" long Grade 8 hex head cap screws and lock nuts are provided. Mounting plate is 15" square with a 12" square bolt pattern.

OUTRIGGERS: An optional outrigger is needed for stability requirements of OSHA 1910.180. The Outrigger is necessary to reduce the load on the crane's rotation mechanism and the truck's suspension.

BOOM REST: A boom rest is required on all Power rotation Model Cranes.



HOUSTON, TEXAS
 FAX: (800) 824-5559 (USA & Canada)
 FAX: (713) 688-6324
 PHONE: (713) 688-5533
 www.liftmoore.com