

CLARK Crane Division

990-TC Specification

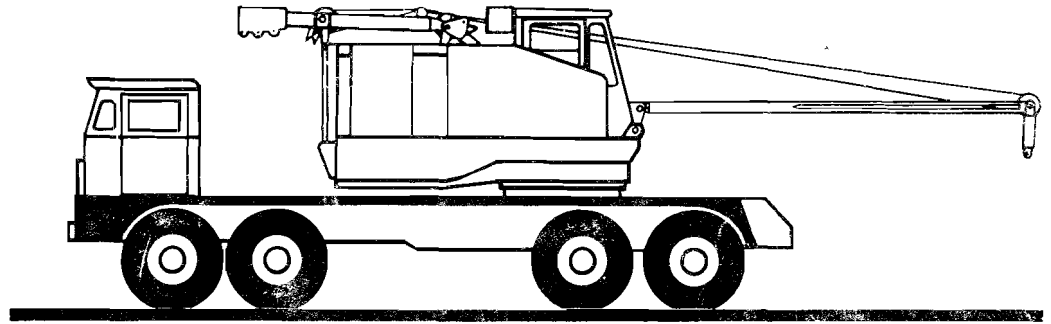



90 Ton Truck Crane

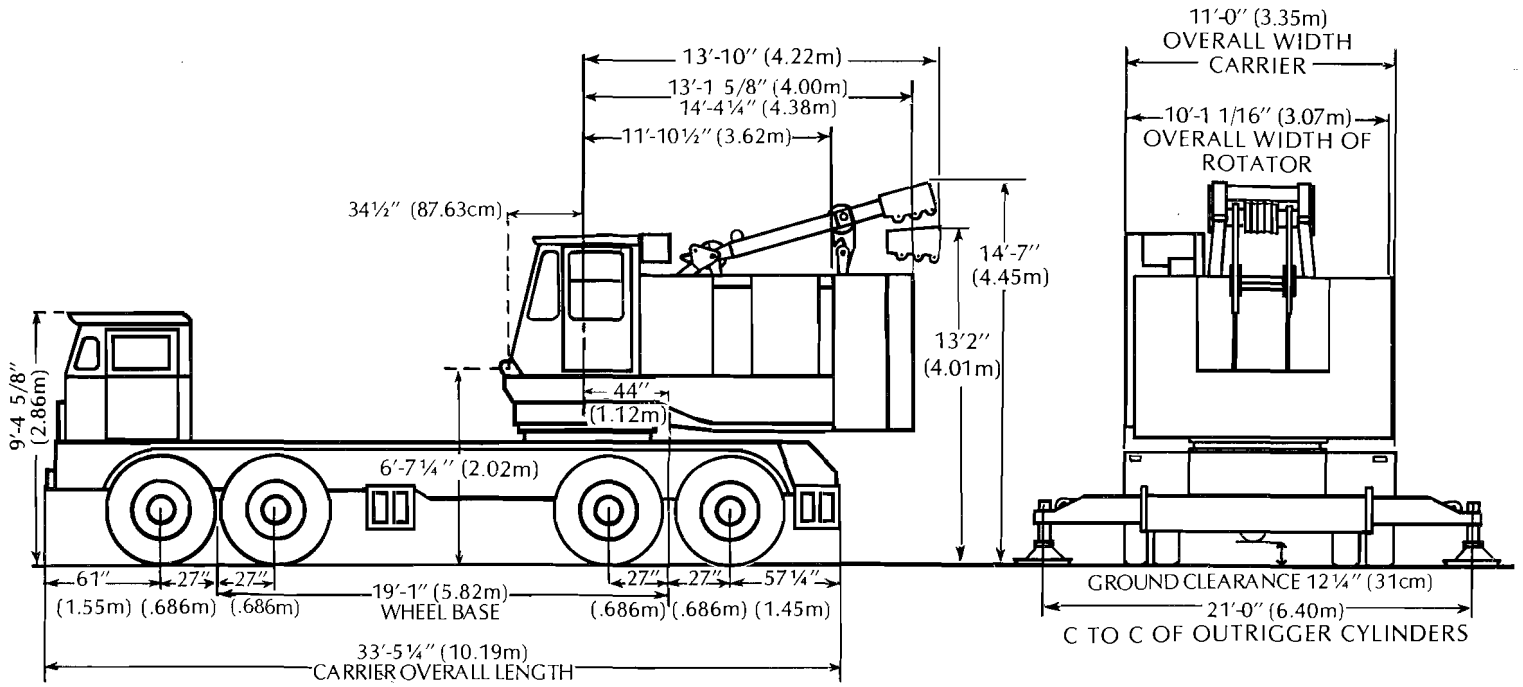

CLEARANCE AND DIMENSIONS

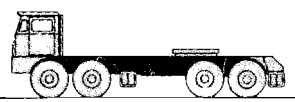
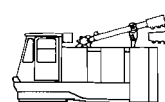

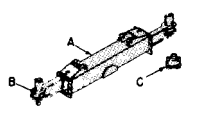
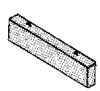
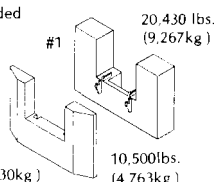
WEIGHTS OF COMPONENT PARTS

<p>CARRIER T-1</p>  <p>Total Weight of Carrier with Standard Diesel Engine and Hydraulic Outriggers.</p> <p>57,955lbs * (26,288kg.)</p>	<p>ROTATOR R-1</p>  <p>Total Weight of Rotating Assembly With Standard Diesel Engine with Torque Converter and 30,930 lbs. (14,030kg.) Counterweight.</p> <p>61,005lbs.* (27,672kg.)</p>	<p>CRANE ATTACHMENT A-2</p>  <p>50' (15.24m) pin connected tubular boom 60 1/4" (153.0cm) x 65 1/4" (163.2cm) with 5 sheaves and rope guard in point; rigid 20' (6.10m) mast and bridle with 12 part reeving and swaged type pendants for basic boom; 16" (40.6cm) smooth rear drum; boom angle indicator, telescopic boomstops with air shut-off; and wire ropes. 980' (298.7m) - 1/4" (19.05mm) dia. wire rope furnished as standard with full width front drum.</p> <p>Meets or exceeds OSHA, and B-30.5</p> <p>10,050lbs.* (4,559kg.)</p>	<p>MISCELLANEOUS</p> <p>Hook Block 1,625lbs. (737kg.) Boom Stop 650lbs. (295kg.) Ball & Hook 8 1/2 Ton (7.72 Ton) 340lbs. (154kg.) Crossover and Basic Pendants— 12 Part Line 950lbs. (431kg.) Mid-Point Suspension 160' (48.77m) thru 200' (60.96m) Boom 640lbs. (290kg.) Operating Ropes 1.04lbs./ft. (1.55kg./m) Deck Mounted Fairlead 745lbs. (338kg.) Tagline Winder 355lbs. (161kg.)</p>
<p>OUTRIGGER BOXES, BEAMS AND FLOATS</p>  <p>HYDRAULIC OUTRIGGERS: A-Outrigger Box (2) ... 2,820lbs (1,279kg) Ea B-Outrigger Beams (4) ... 1,800lbs (816kg) Ea C-Floats (4) ... 110lbs (50kg) Ea.</p> <p>BUMPER CWT. 13,415lbs. (6,085kg.)</p> 	<p>For Third Drum (Subtract) ... 150lbs (68kg)</p> <p>GANTRIES: Back-Hitch Gantry 2,500lbs. (1,134kg.) Basic Gantry 825lbs (374kg)</p> <p>Note: Weight of basic Gantry is Included</p> <p>Counterweight #1 20,430 lbs. (9,267kg) #2 10,500lbs. (4,763kg)</p> <p>COMPLETE ROTATING REAR CWT. 30,930lbs (14,030kg)</p> 	<p>BOOM AND BOOM EXTENSIONS</p> <p>30' (9.14m) Point Section . 2,710lbs. (1,229kg) 20' (6.10m) Base Section . 2,175lbs (987kg.) 10' (3.05m) Extension . 815lbs (370kg.) 20' (6.10m) Extension . 1,285lbs (583kg.) 30' (9.14m) Extension . 1,655lbs (751kg.) 40' (12.19m) Extension . 2,205lbs (1,000kg.)</p> <p>*Main Sheave and Guidesheaves Included in Point Section Weight All Extension weights. Include Pendants</p> <p>JIB</p>  <p>20' (6.10m) Basic Jib Assembly 1,780lbs. (807kg) 10' (3.05m) Jib Extension 420lbs (191kg) 20' (6.10m) Jib Extension 690lbs (313kg.) Maximum Jib Length 60ft (18.29m)</p>	<p>MAST WITH MAST HEAD SHAFT</p>  <p>1,885lbs. (855kg.)</p>

*Per Current Price List Description

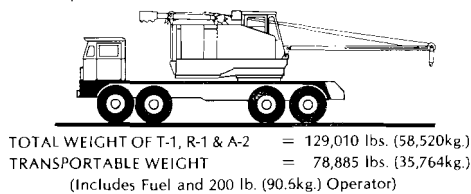

TRANSPORTABLE WEIGHT BASED ON THE REMOVAL OF THE FOLLOWING COMPONENTS FROM T-1, R-1 & A-2

- Counterweight #1
- Counterweight #2
- Floats from Rack
- Rear Box and Beams
- Front Box & Beams
- Boom Point & Pendants
- Boom Stops
- Boom Base

LOAD ON FRONT AXLE
 34,015 lbs. (15,421kg.)

LOAD ON REAR AXLE
 44,870 lbs. (20,343kg.)

EQUIPPED AS FOLLOWS: Truck: Cummins NTC-290 with Jacob brakes, hydraulic outriggers, boom rest and 14:00" x 20" (35.6cmx50.8cm) 20 ply tires. UPPER: Cummins N-855-P-160 power plant with 3 stage converter; includes 50 ft. (15.24M) tubular boom; full width front drum with power load lowering; rear drum with power lowering; boom stops; cables; 30,930 lbs. (14,030kg.) main counterweight and Sprague clutch. Does not include hook block or ball and hook.

AXLE LOADS FOR TRAVEL				
COMPONENT	BOOM POSITION	LOAD ON FRONT AXLE	LOAD ON REAR AXLE	TOTAL AXLE LOAD
COMPLETE MACHINE — CRANE	F	21,190 lbs. (9,612kg.)	107,820 lbs. (48,907kg.)	129,010 lbs. (58,519kg.)
	R	54,380 lbs. (24,667kg.)	74,630 lbs. (33,852kg.)	
ADJUST AXLE LOADING BY REMOVAL OF THE FOLLOWING				
COUNTERWEIGHT NO. 2	F	+ 5,250 lbs. (+ 2,381kg.)	-15,750 lbs. (- 7,144kg.)	-10,500 lbs. (- 4,763kg.)
	R	- 9,285 lbs. (- 4,212kg.)	- 1,215 lbs. (- 551kg.)	
COUNTERWEIGHT NO. 1	F	+ 8,850 lbs. (+ 4,014kg.)	-29,280 lbs. (-13,281kg.)	-20,430 lbs. (-9,267kg.)
	R	-16,700 lbs. (-7,575kg.)	- 3,730 lbs. (-1,692kg.)	
FLOATS FROM RACK	F	- 210 lbs. (- 95kg.)	- 230 lbs. (- 104kg.)	- 440 lbs. (- 199kg.)
	R	- 210 lbs. (- 95kg.)	- 230 lbs. (- 104kg.)	
REAR BOX AND BEAMS	F	+ 1,960 lbs. (+ 889kg.)	- 8,380 lbs. (- 3,801kg.)	- 6,420 lbs. (- 2,912kg.)
	R	+ 1,960 lbs. (+ 889kg.)	- 8,380 lbs. (- 3,801kg.)	
FRONT BOX AND BEAMS	F	- 4,430 lbs. (- 2,009kg.)	- 1,990 lbs. (- 903kg.)	- 6,420 lbs. (- 2,912kg.)
	R	- 4,430 lbs. (- 2,009kg.)	- 1,990 lbs. (- 903kg.)	
BOOM POINT WITH SHEAVES AND PENDANTS	F	- 7,665 lbs. (- 3,477kg.)	+ 4,600 lbs. (+ 2,087kg.)	- 3,065 lbs. (- 1,390kg.)
	R	+ 6,490 lbs. (+ 2,944kg.)	- 9,555 lbs. (- 4,334kg.)	
BOOM STOPS	F	- 420 lbs. (- 191kg.)	- 230 lbs. (- 104kg.)	- 650 lbs. (- 295kg.)
	R	+ 175 lbs. (+ 79kg.)	- 825 lbs. (- 374kg.)	
BOOM BASE	F	- 2,355 lbs. (- 1,068kg.)	- 45 lbs. (- 20kg.)	- 2,400 lbs. (- 1,089kg.)
	R	+ 1,435 lbs. (+ 651kg.)	- 3,835 lbs. (- 1,740kg.)	
MAST WITH MAST SHAFT	F	- 2,335 lbs. (- 1,059kg.)	+ 450 lbs. (+ 204kg.)	- 1,885 lbs. (- 855kg.)
	R	+ 1,610 lbs. (+ 730kg.)	- 3,495 lbs. (- 1,585kg.)	
ROPE — MAIN HOIST	F	- 150 lbs. (- 68kg.)	- 870 lbs. (- 395kg.)	- 1,020 lbs. (- 463kg.)
	R	- 240 lbs. (- 109kg.)	- 780 lbs. (- 354kg.)	
ROPE — AUXILIARY HOIST	F	- 5 lbs. (- 2kg.)	- 535 lbs. (- 243kg.)	- 540 lbs. (- 245kg.)
	R	- 205 lbs. (- 93kg.)	- 335 lbs. (- 152kg.)	
ROPE — BOOM HOIST	F	- 5 lbs. (- 2kg.)	- 485 lbs. (- 220kg.)	- 490 lbs. (- 222kg.)
	R	- 185 lbs. (- 84kg.)	- 305 lbs. (- 138kg.)	

F — DENOTES BOOM EXTENDED FORWARD
R — DENOTES BOOM EXTENDED REARWARD

NOTE: Any deviation from the equipment listed above will affect the weights shown proportionately and compensation must be made accordingly.

POWER PLANT DATA (CARRIER)

	MAKE	MODEL	FUEL	CYL.	BORE & STROKE	RATED H.P.
TRUCK CARRIER	Cummins	NTC-290	Diesel	6	5½" (140mm) x 6" (152mm)	290 @ 2,100
	GM	8V-71	Diesel	8	4½" (108mm) x 5" (127mm)	318 @ 2,100
	Cummins	NTC-350	Diesel	6	5½" (140mm) x 6" (152mm)	250 @ 2,100

PERFORMANCE DATA (CARRIER)

Number of Travel Speeds Standard — 20 Forward and 4 Reverse
Turning Radius — 49 Ft. (On Center Outside Front Tire)

ENGINE MAKE & MODEL	CARRIER EQUIPPED WITH 5 SPEED MAIN & 4 SPEED AUXILIARY TRANS.			
	LOW RANGE*		HIGH RANGE**	
	GRADE	SPEED	GRADE	SPEED
Cummins NTC-290	40.0	1.4MPH (2.25KmPH)	1.0	43.9MPH (70.6KmPH)
NTC-350	40.0	1.4MPH (2.25KmPH)	1.9	43.9MPH (70.6KmPH)
GM 8V-71	40.0	1.3MPH (2.09KmPH)	1.3	43.9MPH (70.6KmPH)

NOTE: The above is based on a machine equipped with a 5 speed Fuller main transmission and a Spicer (4) speed auxiliary transmission and 14:00" x 20" (35.6cm x 50.8cm) tires

Maximum engine torque & machine weighing 129,010 Lbs. (58,519kg.)
Maximum engine speed & machine weighing 74,750 Lbs. (33,907kg.) } These weights apply to a standard equipped machine.

DESCRIPTIVE DATA (CARRIER)

Basic, Standard and Optional Components

FRAME: Carrier frame of heavy-duty, all welded construction. Two main members, each of deep box section, are joined together by bumper and box section cross members. 100,000 P.S.I. (689MPa) steel is used in higher stressed members of frame. Tow hooks, front and rear.

SWING CIRCLE: A large diameter, single row, antifriction bearing assembly with integral swing gear. Bearing is well sealed with close fitting races, eliminating rocking motion of rotating assembly on carrier.

OUTRIGGER BOXES: The two outrigger boxes are fabricated from steel plates. Boxes are of the pin-on design for ease of removal.

OUTRIGGER BEAMS: four, box section extensible beams mounted two in each outrigger box are fabricated of 100,000 P.S.I. (7,030kg/cm²) steel.

HYDRAULIC OUTRIGGERS: Independent control valves for extending each beam and for lowering each hydraulic jack with T-1 steel floats provide precise leveling of truck. Control valve station on carrier at ground level.

FRONT TANDEM SUSPENSION: Front tandem axles are suspended by two alloy steel underslung equalizers, direct-connected to chassis frame. Two radius rods on each axle maintain proper positioning of axles.

FRONT AXLES: Two tubular high clearance type, rating 27,400# (12,429kg.) each. Wheels are mounted on roller bearings.

REAR AXLES: Planetary drive with inter-axle differential. No spin differential is available.

REAR TANDEM SUSPENSION: Rear tandem axles are suspended by two alloy steel underslung equalizers, direct-connected to chassis frame. One torque rod on each axle maintains proper positioning of axles.

WHEELS: Heavy-duty 20" (50.8cm) x 10.0" (25.4cm) rims, four singles in front, four duals in rear, making a total of twelve wheels.

TIRES: Twelve 14.00" (35.6cm) x 20" (50.8cm) 20 ply rating.

FUEL CAPACITY: 85 Gal. (322 Liters)

FENDERS: Fenders are of the combination fender-deck design, providing a flat full width-full length walkway.

SERVICE BRAKES: Air brakes on all wheels. Front brake shoes are 17¼" (44.0cm) diameter x 4" (10.2cm) wide. Rear brake shoes are 16½" (41.9cm.) diameter x 7" (17.8cm.) wide. The carrier engine is equipped with a Jacobs engine brake as standard equipment.

SAFETY BRAKES: Spring set, air released brake cylinders on rear axles lock brakes in case of air loss or for parking. An auxiliary air reservoir and controls allow brakes to be released and reapplied several times after loss of regular air supply.

OPERATING BRAKE: A hand-operated air valve applies the service brakes when required for holding the machine when operating.

STEERING: Hydraulic steering with Ross roller mounted cam and twin lever type steering gear powered by engine driven pump, double acting cylinder and hydraulic control valve built into draglink.

MAIN TRANSMISSION: Fuller with five speeds forward and one reverse.

AUXILIARY TRANSMISSION: Spicer with four speeds giving 20 speeds forward and four reverse.

CLUTCH: Lipe Rollway 14" (35.6cm.) 2-DLB.

CAB: One-man type, with visor type top. All steel construction, amply ventilated for summer or winter. Adjustable seat. Instrument cluster contains speedometer, odometer, ammeter, oil pressure gauge, water temperature gauge, fuel gauge and pilot light. Instrument panel contains air gauge, light switches, ignition and starter switch.

BUMPER COUNTERWEIGHT: One piece, required when using long boom or boom and jib combination. See "boom and jib data."

MISCELLANEOUS ACCESSORIES: Inflating hose and tire pressure gauge, boom rest, rear view mirrors, two beam headlights, stop and tail light, front, middle and rear marker lights and parking lights, electric directional signals, spare wheel with or without tire, air or electric windshield wipers, air and electric dual horns, fender flaps, heater and defrosters.

POWER PLANT DATA (ROTATOR)

ROTATING ASSEMBLY		
MAKE	CUMMINS	G.M.
MODEL	N855-P160	4081
FUEL	Diesel	Diesel
CYL.	6	4
BORE & STROKE	5-1/2" (140mm) x 6" (152mm)	4 1/4" (108mm) x 5" (127mm)
GROSS RATED HP	160 @ 1800	150 @ 2300
TORQUE CONV. HP @ GOVERNED R.P.M.	135 @ 1800	130 @ 1800

LINE PULL	LINE SPEED*	
	1st Layer on Drum 16" (40.6cm) Pitch Dia.	6th Layer On Drum 23 1/2" (59.7cm) Pitch Dia.
16,800lbs (7,620kg)	177fpm (54mpm)	175fpm (53mpm)
13,500lbs (6,124kg)	205fpm (62mpm)	220fpm (67mpm)
10,000lbs (4,536kg)	237fpm (72mpm)	265fpm (81mpm)
6,000lbs (2,722kg)	279fpm (85mpm)	367fpm (112mpm)
2,000lbs (907kg)	323fpm (98mpm)	456fpm (139mpm)

* — Third Drum Speeds Are Approximately 88% of the speeds indicated in the Chart.

CLUTCH AND BRAKE DATA

FUNCTION	CLUTCHES				BRAKES			
	Type	Width	Diameter	Area	Type	Width	Diameter	Area
Main Hoist	Band	5" (12.7cm)	24" (61.0cm)	337 Sq. In. (2,174 Sq. cm)	Band	4 1/2" (11.4cm)	30" (76.2cm)	338 Sq. In. (2,181 Sq. cm)
Auxiliary Hoist	Band	5" (12.7cm)	24" (61.0cm)	337 Sq. In. (2,174 Sq. cm)	Band	4 1/2" (11.4cm)	30" (76.2cm)	338 Sq. In. (2,181 Sq. cm)
3rd Drum Hoist	Band	5" (12.7cm)	24" (61.0cm)	337 Sq. In. (2,174 Sq. cm)	Band	4 1/2" (11.4cm)	30" (76.2cm)	338 Sq. In. (2,181 Sq. cm)
Boom Hoist	Band	5" (12.7cm)	24" (61.0cm)	337 Sq. In. (2,174 Sq. cm)	Band	4 1/2" (11.4cm)	30" (76.2cm)	338 Sq. In. (2,181 Sq. cm)
Swing	2 Shoe	4 1/2" (11.4cm)	24" (61.0cm)	290 Sq. In. (1,871 Sq. cm)	Band	4 1/2" (11.4cm)	30" (76.2cm)	338 Sq. In. (2,181 Sq. cm)
Boom Lowering	Band	4 1/2" (11.4cm)	20" (50.8cm)	248 Sq. In. (1,600 Sq. cm)				
Load Lowering	Band	4 1/2" (11.4cm)	20" (50.8cm)	248 Sq. In. (1,600 Sq. cm)	Band	4" (10.2cm)	26" (66.0cm)	240 Sq. In. (1,548 Sq. cm)
*Front Drum	Band	5" (12.7cm)	24" (61.0cm)	337 Sq. In. (2,174 Sq. cm)	Band	4 1/2" (11.4cm)	30" (76.2cm)	338 Sq. In. (2,181 Sq. cm)

Full width front drum with planetary load lowering.

LAGGING DATA

Lagging Location	Usage	Lagging P.D.	Lagging Width	Type of Lagging	Eff. Capy. 1st Layer	Maximum Capy. & Layers	Wire Rope Size
L.H. Front	Third Drum	14" (35.6cm)	11" (27.9cm)	Smooth	45' (13.7m)	464' (141.4m) In 7	3/4" (19.1mm)
R.H. Front	Crane Auxiliary Hoist	16" (40.6cm)	14-1/2" (36.8cm)	Smooth	71' (21.6m)	569' (173.4m) In 6	3/4" (19.1mm)
R.H. Front	Dragline Drag	16-1/8" (41.0cm)	14-1/2" (36.8cm)	Grooved	49' (14.9m)	—	7/8" (22.2mm)
L.H. Rear	Dragline Hoist	16" (40.6cm)	14-1/2" (36.8cm)	Grooved	48' (14.6m)	—	3/4" (19.1mm)
L.H. Rear	Main Hoist	16" (40.6cm)	14-1/2" (36.8cm)	Smooth	71' (21.6m)	569' (173.4m) In 6	3/4" (19.1mm)
L.H. Rear	Clamshell Closing	16" (40.6cm)	14-1/2" (36.8cm)	Grooved	48' (14.6m)	—	3/4" (19.1mm)
R.H. Front	Clamshell Holding	16" (40.6cm)	14-1/2" (36.8cm)	Grooved	48' (14.6m)	—	3/4" (19.1mm)
R.H. Rear	Boom Hoist	12" (30.5cm)	8-1/2" (21.6cm)	Smooth	28' (8.5m)	372' (113.4m) In 8	3/4" (19.1mm)
Full Width Front Drum	Main or Aux. Hoist	16" (40.6cm)	24-1/8" (61.3cm)	Smooth	123' (37.5m)	959' (292.3m) In 6	3/4" (19.1mm)

MISCELLANEOUS DATA (ROTATOR)

Swing Speed	3.4 RPM	Fuel Capacity 210 Gallons (795 Liters)
-------------	---------	--

DESCRIPTIVE DATA (ROTATING ASSEMBLY)

Basic Standard and Optional Components

ROTATING BASE: Fabricated with integral machinery frames. Fuel tank built in rear.

SHAFTING: All shafting heat treated alloy steel ground to size. Involute splines used extensively.

VERTICAL SWING SHAFT: The vertical swing shaft and pinion is one piece, mounted on anti-friction bearings.

HORIZONTAL SWING SHAFT: This shaft is mounted on anti-friction bearings, geared to the front and rear drum shafts. It supplies power to the vertical swing shaft through a bevel pinion.

SWING BRAKE: A swing brake operates on the outside of the front swing clutch housing for use as a lock brake.

SWING BRAKE WITH SNUBBER: Same as swing brake except an additional control valve on swing lever provided for momentarily holding while setting loads.

JACK SHAFT: This shaft is mounted on ball bearings, and supplies power through a pinion gear to the power lowering shaft. Lube oil pump is belt driven from right hand end of jack shaft.

FRONT DRUM SHAFT: Supported by self-aligning anti-friction bearings and ball bearings. Mounted on the right hand end of this shaft is a swing clutch geared to the horizontal swing shaft. The right hand drum is a split lagging design, either smooth or grooved. All drums are mounted on ball bearings. Refer to "lagging data" table for specifications.

REAR DRUM SHAFT: Supported by self-aligning anti-friction and ball bearings. Mounted on the right hand end of this shaft is a swing clutch geared to the horizontal swing shaft. The right hand or boom hoist drum is solid-type design. The left hand drum is a split lagging design, either smooth or grooved. All drums are mounted on ball bearings. Refer to "lagging data" table for specifications.

HOIST BRAKES: Are external contracting friction band type, mechanically operated by pedals mounted on anti-friction bearings for maximum ease of operation. Hoist brakes have a foot-controlled lock.

CLUTCHES: All clutches are air actuated. All clutches are of the internal expanding friction band type with the exception of the swing clutches which are of the internal two shoe design.

BOOM HOIST: The boom hoist located on the rear drum shaft is of the spur gear and chain design with power up and power down control. Hoisting control is through and air actuated clutch with a spring set, air released holding brake. The brake automatically releases when hoisting or lowering. The lowering is controlled through an air actuated clutch mounted on the power lowering shaft and chain connected to the boom hoist drum. Lowering speed is reduced considerably resulting in a very smooth, precision, lowering operation. A ratchet and pawl device is supplied for added safety.

BOOMS AND JIBS: Extensible type with tubular chords—refer to boom and jib data.

BOOM STOP: Telescopic with or without automatic air cut-off of boom hoist clutch.

FAIRLEAD: Deck mounted, full revolving — optional with crossover suspension only.

BOOM SUSPENSION: Crossover with 12 parts of line and 12 parts with mid-point suspension depending on boom length — optional.

THIRD DRUM: One piece high capacity lagging running on ball bearings, located at left hand side of front drum shaft. Actuated by air operated clutch and brake. Refer to "lagging data" table for specifications.

FULL WIDTH FRONT DRUM: High capacity drum located on the front shaft, mounted on ball bearings and equipped with planetary controlled load lowering. Refer to "lagging data" table for specifications. (Third drum not available with this equipment.)

POWER LOWERING SHAFT: This shaft is located behind the rear hoist drum shaft and accommodates the power boom lowering and power load lowering.

POWER LOAD LOWERING: The power load lowering, air actuated clutch is chain connected to the left hand rear main hoist drum. The load lowering speed is reduced considerably, resulting in a very smooth precision, lowering operation.

COUNTERWEIGHT: Two piece counterweight mounted at rear of rotating frame. Readily removable for weight reduction of machine for transporting.

COUNTERWEIGHT REMOVAL EQUIPMENT: Includes sheaves in base section of boom, lifting slings, and boom stop. Hoist cable over sheaves in boom base is used to load or unload counterweight from auxiliary truck. Gantry power up and down feature is used to position counterweight with slings provided.

GANTRY: Low back hitch gantry. This gantry can be positioned with boom hoist ropes from mast for counterweight handling.

CONTROLS: All controls are air except hoist brakes which are mechanical.

OPERATOR'S CAB: Machine equipped with environmental operator's cab lined with sound barrier and deadening material, cuts noise level by an estimated 50 percent. Cab can be heated or air conditioned. Controls are grouped for maximum operator convenience, comfort and efficiency. Side and front windows slide up and down for ventilation. Numerous hatches and doors are provided for access to machinery and power plant. Hoist drums are not covered.

GEARING AND CHAIN DRIVES: All gearing, except rotating pinion and gear, is fully enclosed, running in oil with pump circulation for positive lubrication. The four chain sprockets for boom hoist and load lowering device require hand lubrication. Power take-off chain drive is fully enclosed, running in an oil bath.

MISCELLANEOUS ACCESSORIES: Ball and hook, hook block, electric signal horn, running board (short hook on type).

POWER TAKE-OFF: Disconnect clutch, precision roller chain.

BOOM PLUS JIB ERECTION CAPABILITY WITH COUNTERWEIGHTS #1 AND #2 MOUNTED ON THE MACHINE			
OVER THE REAR OF THE MACHINE WITH OUTRIGGERS EXTENDED AND SET		OVER THE SIDE OF THE MACHINE WITH OUTRIGGERS EXTENDED AND SET	
Without Bumper Counterweight	With Bumper Counterweight	Without Bumper Counterweight	With Bumper Counterweight
200' (61.0m) + 20' (6.1m)	200' (61.0m) + 20' (6.1m)	190' (57.9m) + 20' (6.1m)	200' (61.0m) + 20' (6.1m)
190' (57.9m) + 30' (9.1m)	200' (61.0m) + 30' (9.1m)	180' (54.9m) + 30' (9.1m)	190' (57.9m) + 30' (9.1m)
180' (54.9m) + 40' (12.2m)	200' (61.0m) + 40' (12.2m)	180' (54.9m) + 40' (12.2m)	190' (57.9m) + 40' (12.2m)
180' (54.9m) + 50' (15.2m)	200' (61.0m) + 50' (15.2m)	170' (51.8m) + 50' (15.2m)	180' (54.9m) + 50' (15.2m)
170' (51.8m) + 60' (18.3m)	190' (57.9m) + 60' (18.3m)	170' (51.8m) + 60' (18.3m)	170' (51.8m) + 60' (18.3m)

Boom erection capability on tires with counterweight #1 only mounted on the machine is 140' boom over the side of the machine and 150' boom over the rear of the machine.

Boom erection capability on outriggers with counterweights #1 and #2 mounted on the machine is 200' of boom.

BOOM AND JIB DATA

Boom, Tubular Pin Connected	
Type Service	Crane - Drag - Clamshell
Suspension	Mast and Pendants
Gantry	Low Backhitch
Quan. Sheaves at Point Shaft	5
Convertibility	Crane - Dragline - Clamshell
Dia. Point Sheaves	15 1/4" (40.0cm) P.D. - 1/4" (19.1mm) Cable
Basic Boom Length	50' (15.2m)
Type Chords	3 1/4" (83mm) O.D. 100,000 P.S.I. (689MPa) Steel
Extensions	40' (3.05m), 20' (6.1m), 30' (9.1m) and 40' (12.2m) straight 60 1/4" (153cm) x 65 1/4" (166cm) sec.
Max. Boom Length	Crane 200' (61.0m) Drag & Clam 60' (18.3m)

Jib, Tubular Pin Connected	
Basic Length	20' [25 1/2" (64.8cm) x 34 1/2" (87.6cm sec.)]
Max. Length	60' (18.3m)
Chord Size	2 1/2" (64mm) O.D.
Chord Material	100,000 P.S.I. (689MPa) Yield
Quan. Sheaves at Point	One (1)
P.D. Point Sheave	15 1/4" (40cm) P.D. [1/4" (19.1mm) Cable]
Capacity — 20'-0" (6.1m)	a., b., c. 16.8 Tons (15.2 Tons)
30'-0" (9.1m)	a., b. 16.8 Tons (15.2 Tons)
40'-0" (12.2m)	a. 16.8 Tons (15.2 Tons)
50'-0" (15.2m)	a. 14.5 Tons (13.1 Tons)
60'-0" (18.3m)	a. 11.8 Tons (10.7 Tons)
	a. Minimum Jib Offset
	b. Intermediate Jib Offset
	c. Maximum Jib Offset

BOOM HOIST SUSPENSION DATA

*Boom Length	Reeving Required	Mid-Point Suspension Location
Up thru 150' (45.7m)	Mast And Pendants	Midpoint Not Required
160' (48.77m) thru 200' (60.96m)	Mast, Pendants And Midpoint	100' (30.48m) From Boom Foot

* Boom length determines suspension required. Jib does not affect requirement.

Time Required to Raise Or Lower A 50' (15.2m) Boom From 20° Above Horizontal To 70° Above Horizontal With 12 Part Boom Hoist Reeving	to Raise	To Lower
		55 Sec.

CRANE WORKING RANGES

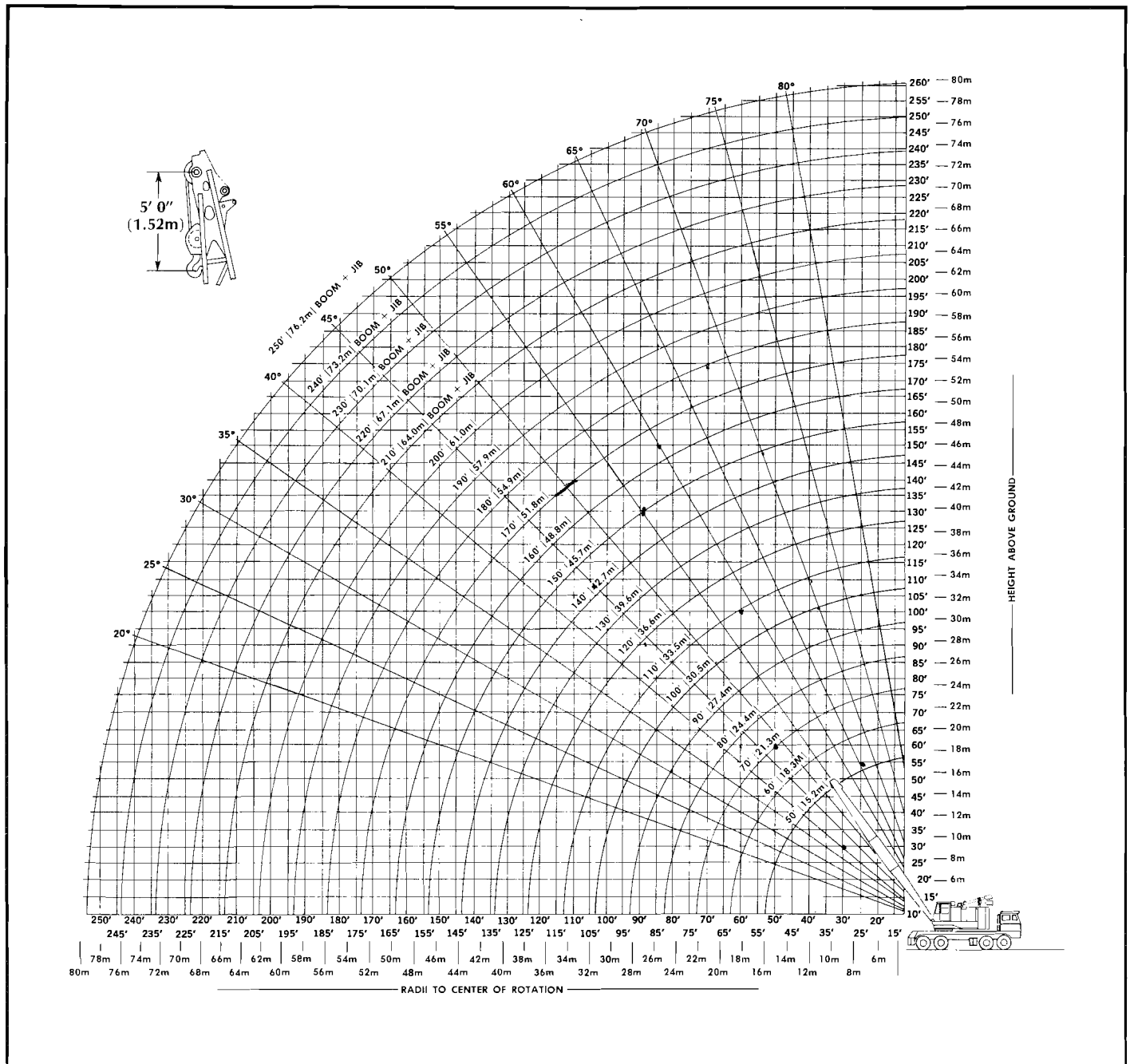

RECOMMENDED WIRE ROPE REEVING FOR HOOK BLOCKS

Load in Pounds	No. Part Line	Load in Pounds	No. Part Line
Over 16,800lbs. (7,620kg.)	2	Over 100,800lbs. (45,720kg.)	7
Over 33,600lbs. (15,240kg.)	3	Over 117,600lbs. (53,340kg.)	8
Over 50,400lbs. (22,860kg.)	4	Over 134,400lbs. (60,960kg.)	9
Over 67,200lbs. (30,480kg.)	5	Over 151,200lbs. (68,580kg.)	10
Over 84,000lbs. (38,100kg.)	6	Over 168,000lbs. (76,200kg.)	11

Based upon 3/4" dia. wire rope with a minimum breaking strength of 58,800lbs.

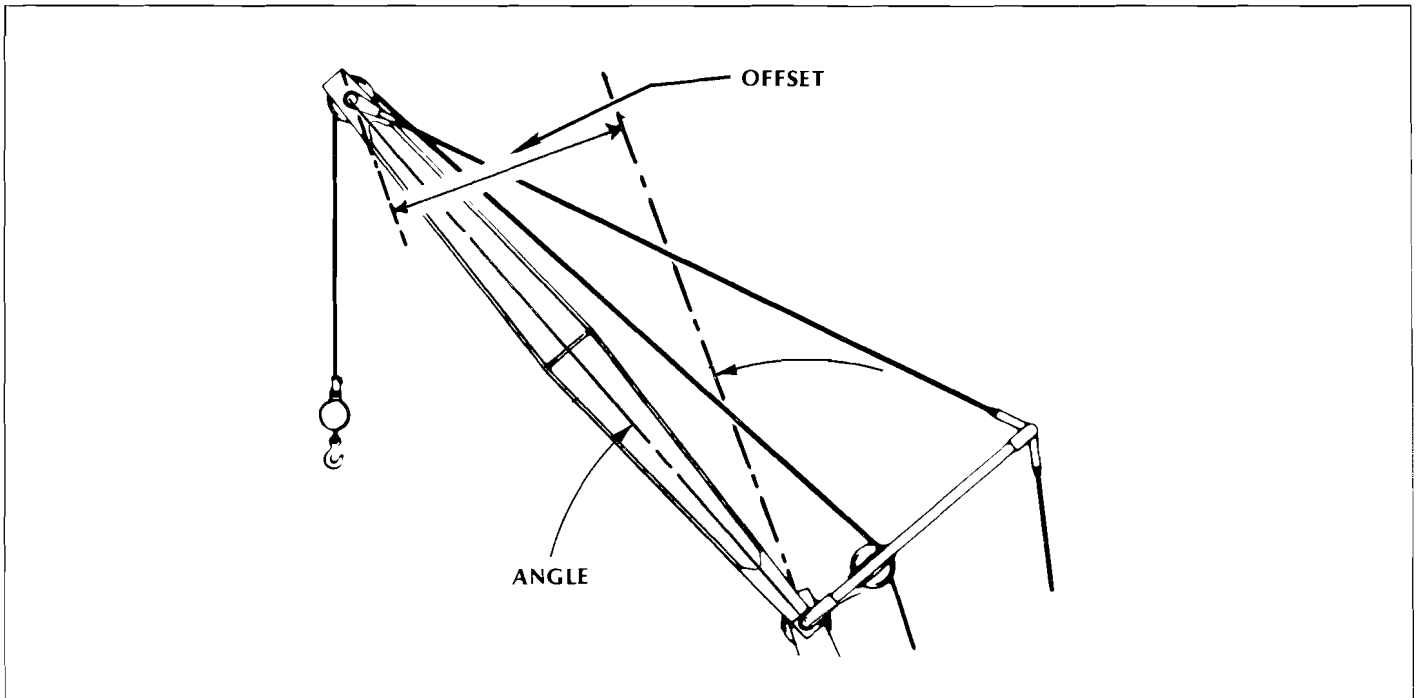

JIB DATA				
Length	OFFSET			Weight
	Position	Distance	Angle	
20' (6.1m)	Minimum	1'- 3" (.38m)	3.7°	1,945lbs. (882kg.)
	Intermediate	4'- 8" (1.42m)	13.4°	1,945lbs. (882kg.)
	Maximum	8'- 0" (2.44m)	23.6°	1,945lbs. (882kg.)
30' (9.1m)	Minimum	3'- 0" (.91m)	5.8°	2,370lbs. (1,075kg.)
	Intermediate	8'- 0" (2.44m)	15.5°	2,370lbs. (1,075kg.)
	Maximum	13'- 1" (3.99m)	25.8°	2,370lbs. (1,075kg.)
40' (12.2m)	Minimum	4'- 3" (1.30m)	6.1°	2,795lbs. (1,268kg.)
	Intermediate	10'-11" (3.33m)	15.8°	2,795lbs. (1,268kg.)
	Maximum	17'- 7" (5.36m)	26.1°	2,795lbs. (1,268kg.)
50' (15.2m)	Minimum	4'-11" (1.50m)	5.6°	3,065lbs. (1,390kg.)
	Intermediate	13'- 3" (4.04m)	15.3°	3,065lbs. (1,390kg.)
	Maximum	21'- 7" (6.58m)	25.6°	3,065lbs. (1,390kg.)
60' (18.3m)	Minimum	5'- 0" (1.52m)	4.8°	3,490lbs. (1,583kg.)
	Intermediate	15'- 1" (4.60m)	14.5°	3,490lbs. (1,583kg.)
	Maximum	25'- 2" (7.67m)	24.8°	3,490lbs. (1,583kg.)

MAIN BOOM CAPACITY REDUCTION DUE TO A JIB MOUNTED ON THE BOOM			
Jib Length	JIB OFFSET		
	Minimum	Intermediate	Maximum
20' (6.1m)	1,900lbs. (862kg.)	2,000lbs. (907kg.)	2,100lbs. (953kg.)
30' (9.1m)	2,600lbs. (1,179kg.)	2,800lbs. (1,270kg.)	3,100lbs. (1,406kg.)
40' (12.2m)	3,600lbs. (1,633kg.)	4,000lbs. (1,814kg.)	4,800lbs. (2,177kg.)
50' (15.2m)	4,400lbs. (1,996kg.)	5,400lbs. (2,449kg.)	7,700lbs. (3,493kg.)
60' (18.3m)	5,700lbs. (2,586kg.)	7,800lbs. (3,538kg.)	15,800lbs. (7,167kg.)

CRANE LIFTING CAPACITIES

90 Ton Class 15-484														
Boom				Outriggers Extended and Set	On Tires			Boom				Outriggers Extended and Set	On Tires	
Length	Radius	*Angle	Height		Side/Rear	Side	Rear	Length	Radius	*Angle	Height		Side/Rear	Side
50'	15'	75.9	55.1'	*180,000	*49,600	*64,200	120'	22.2'	80.7	125.0'	85,500	*32,650	43,500	
	20'	69.9	53.5'	*130,000	*38,100	50,800		25'	79.3	124.5'	80,700	*28,800	37,300	
	25'	63.7	51.4'	101,900	*30,600	38,100		30'	76.9	123.5'	72,800	*23,600	29,300	
	30'	57.1	48.6'	74,900	25,100	30,300		35'	74.4	122.2'	58,700	19,600	23,900	
	35'	50.0	44.9'	59,000	20,500	24,900		40'	71.9	120.7'	48,000	16,200	20,000	
	40'	42.0	40.1'	48,400	17,200	21,000		45'	69.4	118.9'	40,400	13,700	17,000	
	45'	32.5	33.5'	40,900	14,600	18,000		50'	66.8	116.9'	34,700	11,700	14,700	
60'	15'	78.3	65.3'	*170,000	*49,400	*63,800	120'	60'	61.5	112.1'	26,800	8,800	11,300	
	20'	73.4	64.1'	*129,000	*37,900	50,800		70'	55.9	106.0'	21,500	6,700	8,900	
	25'	68.3	62.3'	100,500	*30,300	38,100		80'	50.0	98.5'	17,700	5,200	7,100	
	30'	63.1	60.1'	75,100	*25,050	30,200		90'	43.4	89.1'	14,900	4,100	5,700	
	35'	57.6	57.2'	59,000	20,400	24,800		100'	35.9	77.0'	12,700	3,100	4,600	
	40'	51.7	53.7'	48,400	17,100	20,900		110'	26.7	60.6'	10,900	2,400	3,800	
	45'	45.4	49.3'	40,900	14,500	17,900		120'	12.5	32.7'	9,500	1,700	3,000	
70'	15'	80.0	75.5'	*140,000	*49,300	*63,700	130'	23.9'	80.7	134.9'	76,200	*29,900	39,500	
	20'	75.8	74.4'	122,000	*37,500	50,700		25'	80.2	134.7'	75,500	*28,450	37,100	
	25'	71.5	73.0'	98,200	*30,000	37,900		30'	77.9	133.7'	69,900	*23,250	29,100	
	30'	67.2	71.1'	75,100	*24,800	30,000		35'	75.6	132.5'	58,700	19,400	23,700	
	35'	62.6	68.8'	59,000	20,300	24,600		40'	73.4	131.1'	47,900	16,000	19,800	
	40'	57.9	65.9'	48,400	16,900	20,700		45'	71.0	129.5'	40,300	13,400	16,800	
	45'	53.0	62.5'	40,800	14,400	17,800		50'	68.7	127.7'	34,600	11,400	14,500	
80'	15.5'	80.9	85.6'	*128,500	*47,400	*62,000	140'	60'	63.9	123.3'	26,600	8,500	11,000	
	20'	77.6	84.7'	115,600	*37,300	50,600		70'	58.9	117.9'	21,300	6,500	8,600	
	25'	73.9	83.4'	95,900	*29,800	37,800		80'	53.6	111.2'	17,500	5,000	6,900	
	30'	70.1	81.8'	75,100	*24,600	29,900		90'	47.9	103.0'	14,700	3,800	5,500	
	35'	66.3	79.8'	59,000	20,200	24,500		100'	41.6	93.0'	12,500	2,900	4,400	
	40'	62.3	77.4'	48,300	16,800	20,600		110'	34.5	80.2'	10,700	2,100	3,500	
	45'	58.2	74.6'	40,800	14,300	17,700		120'	25.7	63.0'	9,300	1,500	2,800	
90'	17.2'	80.8	95.5'	*114,800	*42,700	*58,000	150'	130'	12.0	33.8'	8,100	1,500	2,100	
	20'	79.0	94.9'	108,800	*36,950	50,400		25.6'	80.6	144.7'	*70,200	*27,500	36,000	
	25'	75.7	93.8'	94,300	*29,800	37,700		30'	78.8	143.9'	*63,800	*23,000	29,000	
	30'	72.4	92.4'	75,100	*24,250	29,700		35'	76.7	142.8'	58,500	*19,150	23,500	
	35'	69.0	90.6'	58,900	20,000	24,300		40'	74.6	141.5'	47,800	15,800	19,600	
	40'	65.6	88.5'	48,200	16,600	20,400		45'	72.4	140.1'	40,100	13,300	16,600	
	45'	62.0	86.1'	40,700	14,100	17,500		50'	70.3	138.4'	34,400	11,300	14,300	
100'	18.8'	80.8	105.3'	*104,300	*39,000	54,700	140'	60'	65.9	134.4'	26,400	8,300	10,800	
	20'	80.1	105.1'	102,400	*36,700	50,300		70'	61.3	129.4'	21,100	6,300	8,400	
	25'	77.2	104.1'	92,700	*29,250	37,500		80'	56.5	123.4'	17,400	4,800	6,700	
	30'	74.2	102.8'	74,800	*24,000	29,600		90'	51.5	116.1'	14,500	3,600	5,300	
	35'	71.2	101.3'	58,900	19,800	24,200		100'	46.0	107.4'	12,300	2,700	4,200	
	40'	68.2	99.4'	48,200	16,500	20,300		110'	40.0	96.7'	10,600	2,000	3,300	
	45'	65.0	97.3'	40,600	13,900	17,300		120'	33.2	83.3'	9,100	1,900	2,600	
110'	50'	61.8	94.8'	34,900	11,900	15,000	150'	130'	24.7	65.2'	7,900	1,500	2,000	
	55'	55.1	88.6'	27,000	9,000	11,500		140'	11.6	34.8'	6,900			
	60'	47.8	80.7'	21,700	7,000	9,100		27.3'	80.6	154.6'	*62,800	*25,200	32,900	
	65'	39.5	70.2'	17,900	5,500	7,400		30'	79.6	154.1'	*59,300	*22,800	28,800	
	70'	29.4	55.6'	15,100	4,300	6,000		35'	77.6	153.1'	*54,600	*18,950	23,400	
	75'	13.7	30.4'	12,900	3,300	4,900		40'	75.6	151.9'	47,700	15,700	19,500	
	80'	20.5'	80.7	115.2'	93,800	*35,700		48,900	45'	73.6	150.5'	40,000	13,100	16,500
120'	25'	78.4	114.2'	87,500	*29,100	37,500	§ 160'	50'	71.6	149.0'	34,300	11,100	14,100	
	30'	75.7	113.2'	73,600	*23,900	29,500		60'	67.6	145.3'	26,300	8,200	10,700	
	35'	73.0	111.8'	58,800	19,800	24,100		70'	63.4	140.7'	21,000	6,100	8,300	
	40'	70.2	110.1'	48,100	16,400	20,200		80'	59.0	135.2'	17,200	4,600	6,500	
	45'	67.4	108.2'	40,500	13,800	17,200		90'	54.4	128.7'	14,400	3,500	5,200	
	50'	64.6	106.0'	34,800	11,800	14,900		100'	49.6	120.9'	12,200	2,600	4,100	
	55'	58.7	100.6'	26,900	8,900	11,500		110'	44.4	111.6'	10,400	2,500	3,200	
	60'	52.3	93.7'	21,600	6,900	9,100		120'	38.6	100.3'	9,000			
	65'	45.4	85.0'	17,900	5,400	7,300		130'	32.0	86.2'	7,800			
	70'	37.6	73.7'	15,100	4,200	5,900		140'	23.9	67.4'	6,800			
	75'	28.0	58.2'	12,900	3,300	4,800		150'	11.2	35.8'	5,900			

Maximum Counterweight: Outriggers Extended and set 30,930 lbs.
 On rubber tires 20,430 lbs.

Length	Boom			Outriggers Extended and Set ‡Side/Rear	On Tires	
	Radius	*Angle	Height		‡Side	Rear
§ 170'	35.5'	78.9	173.5'	*50,700		
	40'	77.3	172.5'	47,400		
	45'	75.6	171.3'	39,700		
	50'	73.9	169.9'	33,900		
	60'	70.3	166.7'	25,900		
	70'	66.7	162.7'	20,600		
	80'	63.0	158.1'	16,700		
	90'	59.1	152.5'	13,900		
	100'	55.1	146.1'	11,700		
	110'	50.9	138.6'	9,900		
	120'	46.4	129.8'	8,400		
	130'	41.6	119.4'	7,200		
	140'	36.2	107.0'	6,200		
150'	30.0	91.7'	5,300			
160'	22.4	71.5'	4,600			
170'	10.5	37.7'	3,900			
§ 180'	36.6'	79.1	183.4'	*45,300		
	40'	78.1	182.7'	*45,000		
	45'	76.4	181.6'	39,400		
	50'	74.8	180.3'	33,700		
	60'	71.5	177.3'	25,600		
	70'	68.1	173.6'	20,300		
	80'	64.6	169.2'	16,500		
	90'	61.0	164.1'	13,600		
	100'	57.3	158.1'	11,400		
	110'	53.4	151.2'	9,600		
	120'	49.4	143.2'	8,200		
	130'	45.0	134.0'	7,000		
	140'	40.3	123.2'	5,900		
150'	35.1	110.3'	5,100			
160'	29.2	94.4'	4,300			
170'	21.8	73.4'	3,600			
180'	10.2	38.6'	3,000			
§ 190'	37.7'	79.4	193.4'	*39,600		
	40'	78.7	192.9'	*39,100		
	45'	77.1	191.8'	*38,600		
	50'	75.6	190.6'	33,600		
	60'	72.5	187.8'	25,500		
	70'	69.3	184.3'	20,200		
	80'	66.0	180.2'	16,400		
	90'	62.7	175.4'	13,500		
	100'	59.2	169.9'	11,300		
	110'	55.6	163.5'	9,500		
	120'	51.9	156.2'	8,100		
	130'	48.0	147.8'	6,800		
	140'	43.8	138.1'	5,800		
150'	39.2	126.8'	4,900			
160'	34.2	113.4'	4,200			
170'	28.4	96.9'	3,500			
180'	21.2	75.3'	2,900			
190'	9.9	39.5'	2,400			
§ 200	38.8'	79.6	203.4'	*33,700		
	40'	79.3	203.1'	*33,600		
	45'	77.8	202.1'	*33,300		
	50'	76.3	200.9'	*33,000		
	60'	73.4	198.2'	25,400		
	70'	70.3	195.0'	20,100		
	80'	67.3	191.1'	16,200		
	90'	64.1	186.6'	13,400		
	100'	60.9	181.4'	11,100		
	110'	57.6	175.5'	9,400		
	120'	54.1	168.7'	7,900		
	130'	50.5	161.0'	6,700		
	140'	46.7	152.2'	5,700		
150'	42.6	142.0'	4,800			
160'	38.2	130.3'	4,000			
170'	33.3	116.4'	3,300			
180'	27.6	99.4'	2,700			
190'	20.6	77.2'	2,200			

‡Requires #1 & #2 Counterweights
 § = Midpoint suspension required

‡Indicates that side is the least stable charted direction.

**DIAGRAMMATIC DEFINITION OF "SIDE", "REAR",
 OR "FRONT" AS USED ON CAPACITY CHARTS.**

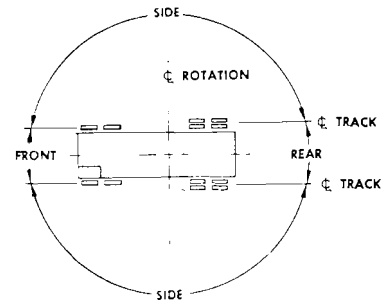

"ON TIRES"

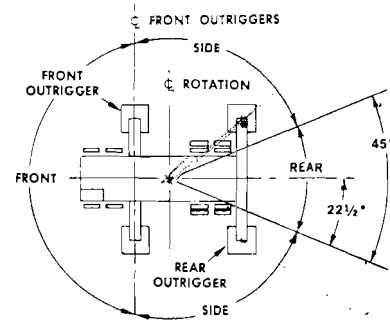

**"ON OUTRIGGERS"
 FULLY EXTENDED & SET**

Capacities per SAE Code J765

Class Designation per U.S. Department of Commerce Standards.

THIS CHART IS BASED UPON:

1. Loads marked by * are the maximum loads permitted by the structural strength of the parts and are not based upon the stability of the machine.
2. All other loads are based upon the stability of the machine, and do not exceed 85% of the tipping loads in the least stable direction.
3. Machine to be level on firm solid support; shock and side loads are to be prevented.
4. All hook blocks, lifting tackle and jib attachments are considered a part of the load to be lifted.
5. Loads must not be lifted or handled over the front of the machine — See Diagram.
6. "On Tires" capacities are not recommended for traveling (Refer to Lima for travel load ratings).
7. Exceeding the capacities shown on this chart or altering the counterweight nullifies all warranties.
8. When the machine is equipped with the 30,930 lb. counterweight and resting on rubber tires, the counterweight must never be swung over side or rear of the machine — the centerline of the rotating unit and the centerline of the truck must be parallel.
9. The load ratings shown on this chart make no allowance for such factors as the effect of side loads, wind, ground conditions, inflation of rubber tires, and operating speeds. The operator shall therefore reduce load ratings to take these factors into account.

