

Specifications

Telescopic Boom Truck Crane

HTC-8650

50-ton (45.36 metric tons)

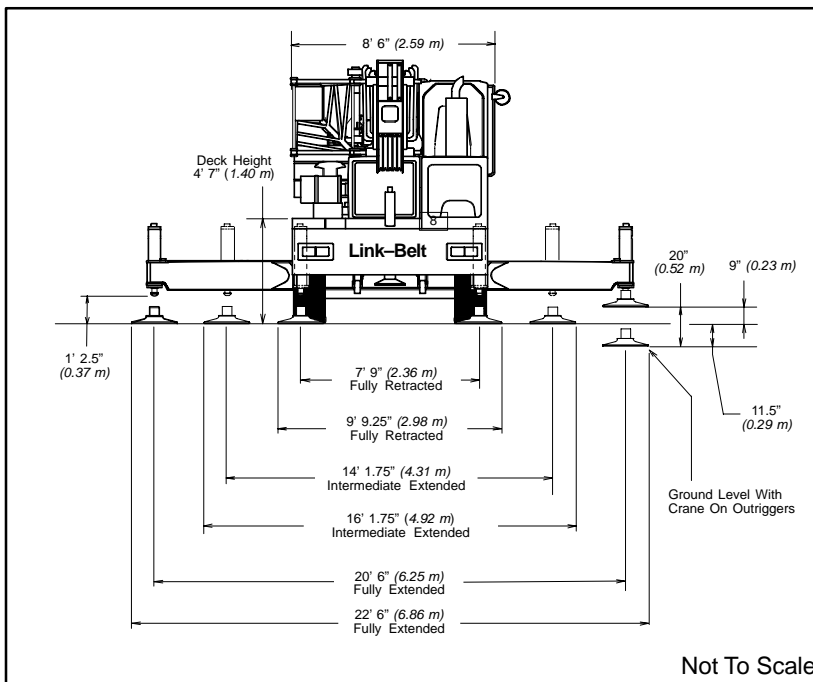
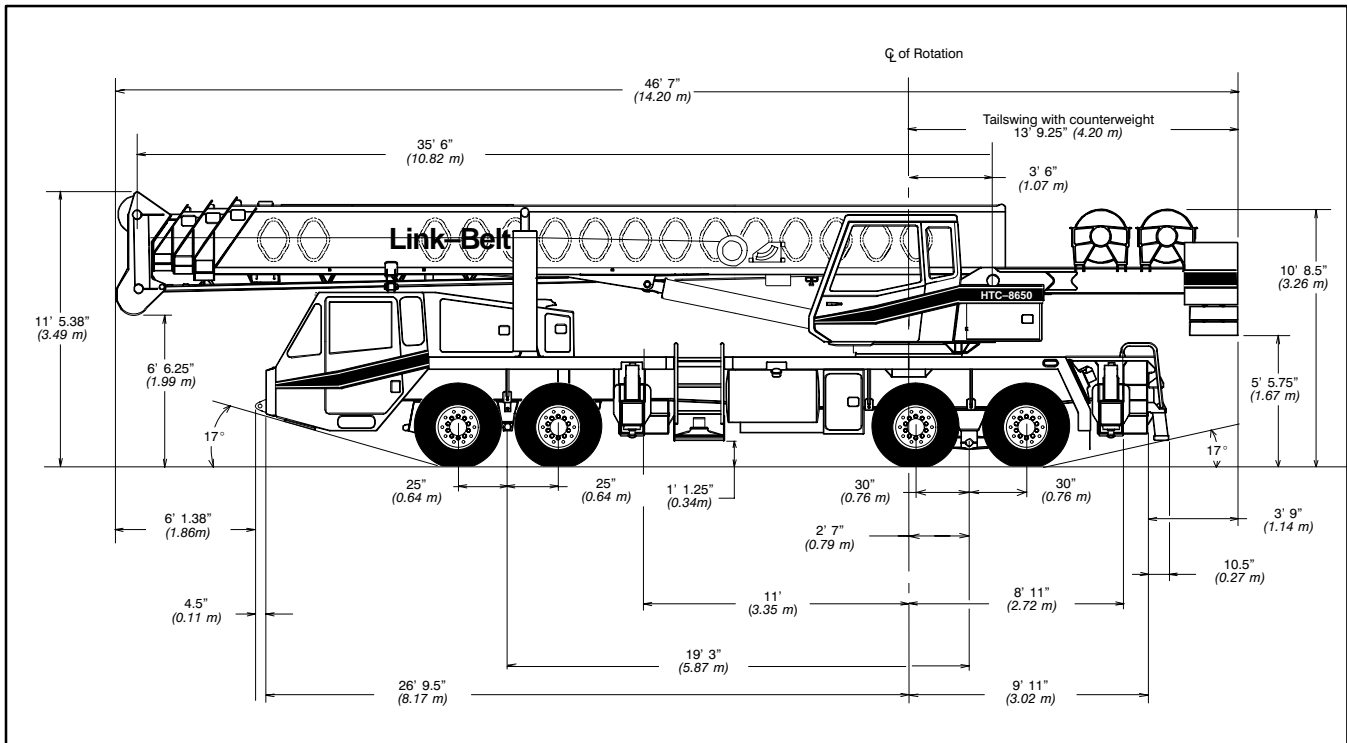

General Dimensions	feet	meters
Turning radius – wall to wall	45' 10"	13.97
Turning radius – curb to curb	38' 10"	11.84
Ground clearance	13.25"	0.34
Tailswing	13' 9.25"	4.20

Upper Structure

■ Boom

Patented Design

- Boom side plates have diamond shaped impressions for superior strength to weight ratio and 100,000 p.s.i. (689.5 MPa) steel angle chords for lateral stiffness.
- Boom telescope sections are supported by top, bottom and adjustable side wear shoes to prevent metal to metal contact.

Boom

- 35.5' – 110' (10.82 – 33.53 m) four-section full-power boom
- Two mode boom extension
- The basic mode is the full power, synchronized mode of telescoping all sections proportionally to 110' (33.53 m).
- The exclusive "A-max" mode (or mode 'A') extends only the inner mid section to 60.3' (18.38 m) offering increased capacities for in-close, maximum capacity picks.
- Mechanical Boom Angle Indicator

Boom Head

- Four 16.5" (0.42 m) root diameter nylon sheaves to handle up to eight parts of wire rope.
- Easily removable wire rope guards
- Rope dead end lugs provided on each side of boom head.
- Boom head designed for quick reeve of hook block.
- Fifth head sheave is optional

Boom Elevation

- Two Link-Belt designed hydraulic cylinders with holding valves and bushings in each end.
- Hand control for controlling boom elevation from -3° to +78°.

Optional Auxiliary Lifting Sheave

- Single 16.5" (0.42 m) root diameter nylon sheave with removable wire rope guard, mounted to boom.
- Use with one or two parts of line off the optional front winch.
- Does not affect erection of fly or use of main head sheaves for multiple reeving.

Optional

- 40-ton (36.3 mt) quick-reeve hook block
- 60-ton (54.43 mt) quick-reeve hook block
- 70-ton (63.30 mt) quick-reeve hook block
- 8.5-ton (7.71 mt) hook ball
- Boom floodlight

■ Fly

Optional

- 34' (10.36 m) one-piece lattice fly, stowable, offsettable to 2°, 20° and 40°
- 34' – 56' (10.36 – 17.07 m) two-piece (bi-fold) lattice fly, stowable, offsettable to 2°, 20° and 40°

■ Cab and Controls

Environmental Ultra-Cab™

- Laminated fibrous composite material; isolated from sound with acoustical fabric insulation.

- Windows are tinted and tempered safety glass
- Sliding rear and right side windows and swing-up roof window for maximum visibility and ventilation.
- Slide-by-door opens to 3' (0.91 m) width.
- Six-way adjustable seat, with seat belt, for maximum operator comfort.
- Hand held outrigger controls and sight level bubble located in cab.
- Top hatch window wiper
- Audible swing alarm
- Fire extinguisher
- Sun screen
- Electric windshield wiper
- Windshield washer
- Cab work lights
- Pull-out Cabwalk™

Optional

- Amber strobe light
- Third wrap indicator
- Amber rotating beacon
- Diesel or hydraulic heater
- RCL light bar
- Air conditioning

Controls

Hydraulic controls (joystick type) for:

- Swing
- Optional auxiliary winch
- Main winch
- Boom hoist

Foot controls for:

- Boom telescope
- Swing brake
- Engine throttle

Optional

- Auxiliary winch
- Single axis controls

Cab Instrumentation

Cornerpost-mounted gauges for:

- Hydraulic oil temperature
- Audio/Visual warning system
- Check and stop engine indicator lights
- Tachometer
- Voltmeter
- Water temperature
- Oil pressure
- Fuel

■ Rated Capacity Limiter

- **Microguard 434** Graphic audio-visual warning system built into dash with anti-two block and function limiters.

Operating data available includes:

- Machine configuration.
- Boom length
- Head height
- Allowed load
- % of allowed load
- Boom angle
- Radius of load
- Actual load

Pre-settable alarms include:

- Maximum and minimum boom angles
- Maximum tip height
- Maximum boom length
- Swing left/right positions
- Operator defined area alarm is standard
- Anti-two block weight designed for quick reeve of hookblock

Optional

- **Internal RCL light bar:** Visually informs operator when crane is approaching maximum load capacity with a series of green, yellow and red lights.

- **External RCL light bar:** Visually informs ground crew when crane is approaching maximum load capacity kickouts and pre-settable alarms with a series of three lights; green, yellow and red.

■ Swing

- Bi-directional hydraulic swing motor mounted to a planetary reducer for 360° continuous smooth swing at 2.2 r.p.m.
- **Swing park brake** – 360°, electric over hydraulic (spring applied, hydraulic released) multi-disc brake mounted on the speed reducer. Operated by toggle switch in overhead control console.
- **Swing brake** – 360°, foot operated, hydraulic applied disc brake mounted on the speed reducer.
- **Swing lock** – Standard; two position travel lock (pin device) operated from the operator's cab.
- **Counterweight**
 - Standard – Bolted to upper structure frame. 11,000 lbs. (4 990 kg) three piece design. Consist of one 5,000 lbs. (2 268 kg) piece bolted to upper structure and two 3,000 lbs. (1 361 kg) pieces pinned to standard counterweight.
 - Two counterweight sections can be hydraulically lowered on, and pinned to carrier deck to balance axle loadings for travel.
- **Optional**
 - 360° swing lock. Meets New York City requirements
 - 6,000 lbs. (2 722 kg) counterweight

■ Hydraulic System

Main Pump

- One gear pump with a total of four sections
- Combined pump capacity of 176 gpm (666 lpm)
- Powered by carrier engine with pump disconnect
- Rocker switch controlled, air applied pump disconnect engaged / disengaged from carrier cab.
- Maximum system operating pressure is 3,000 psi (20 685 kPa).
- O-ring face seals technology used throughout with hydraulic oil cooler standard.

Pilot Pressure / Counterweight Removal Pump

- Pressure compensated piston pump powered by carrier engine. Max pump operating pressure is 1,500 psi (10 342 kPa).

Steering / Fifth Outrigger Pump

- Single gear type pump, 8 gpm (30 lpm). Powered by carrier engine through front gear housing.
- Maximum pump operating pressure is 2,000 psi (13 790 kPa).

Reservoir

- 169 gallon (639.7 L) capacity. One diffuser for deaeration.

Filtration

- One 10-micron filter located inside hydraulic reservoir.
- Accessible for easy replacement

Control valves

- Six separate pilot operated control valves allow simultaneous operation of all crane functions.

Load Hoist System

Standard

- 2M main winch with grooved lagging

- Two-speed motor and automatic brake
- Power up/down mode of operation
- Bi-directional gear-type hydraulic motor driven through planetary reduction unit for positive control under all load conditions.
- Asynchronous parallel double crossover grooved drums minimize rope harmonic motion.
- Pressure compensated winch circuit provides balanced oil flow to both winches for smooth, simultaneous operation.
- Rotation resistant wire rope
- Drum rotation indicators

Line Pulls and Speeds

- Maximum available line pull 16,407 lbs. (7 442 kg) and maximum line speed of 463 f.p.m. (141 m/min) on 16" (0.41 m) root diameter grooved drum.

Optional

- 2M auxiliary winch with two-speed motor, automatic brake, and winch function lock-out. Power up/down modes.
- Third wrap indicators

Carrier

Type

- 8' 6" (2.59 m) wide, 231" (5.87 m) wheel-base. 8 x 4 drive – standard.

Frame

- 100,000 p.s.i. (689.5 MPa) steel, double walled construction with integral 100,000 p.s.i. steel outrigger boxes.

Optional

- Carrier mounted storage boxes
- Pintle hook
- Electric and air connections for trailers and boom dollies

Axles

Front

- Single, 83.72" (2.13 m) track

Rear

- Tandem, 72.8" (1.85 m) track. 6.17 to 1.0 ratio with interaxle differential with lockout.

Suspension

Front axle

- Leaf spring suspension

Rear axle

- Air-ride, bogie beam type, suspension.

Wheels

Standard

- Hub piloted steel disc

Optional

- Hub piloted aluminum disc
- Spare tire and wheel assemblies

Tires

Standard Front

- 425/65R22.5 (Load range "L") single tubeless radials

Standard Rear

- 12R22.5 (Load range "H") dual tubeless radials

Optional

- 445/65R22.5 (Load Range "L") Single tubeless radials front 12R22.5 (Load range "H") dual tubeless radials rear – mounted on steel disc wheels front/rear.

Brakes

Service

- Full air brakes on all wheel ends with automatic slack adjusters. Dual circuit with modulated emergency brakes.
- Front – 16.5 x 6 S-Cam brakes
- Rear – 16.5 x 7 S-Cam brakes

Parking/Emergency

- One spring set, air released chamber per rear axle end.
- Parking brake applied with valve mounted on carrier dash.
- Emergency brakes apply automatically when air drops below 60 psi (413.7 kPa) in both systems.

Steering

- Sheppard rack and pinion design

Transmission

Standard

- Eaton RTO 11909ALL; 11 speeds forward, 3 reverse with Series 50 engine.

Optional

- Eaton RTO-14909ALL; 11 speeds forward, 3 reverse with Series 60 engine.

Electrical

- Two 12-volt batteries provide 12-volt starting. 130-amp alternator
- 2,800 cold cranking amps available
- 12-volt operating system

Lights

- Four dual beam sealed headlights
- Front, side, and rear directional signals
- Stop, tail and license plate lights
- Rear and side clearance lights
- Hazard warning lights

Outriggers

- Three position operation capability.
- Four hydraulic, telescoping beam and jack outriggers.
- Vertical jack cylinders equipped with integral holding valve.
- Beams extend to 20' 6" (6.25 m) centerline-to-centerline and retract to within 8' 6" (2.59 m) overall width.
- Equipped with stowable, lightweight 24" (0.61 m) diameter aluminum floats.
- Standard fifth outrigger, 14 3/4" (0.37 m) self storing steel pad is operable from ground or operator's cab.
- Hand-held controls and sight level bubble located in operators cab and on carrier deck.

Confined Area Lifting Capacities (CALC™) System

- The crane is operational in one of the three outriggers positions and operational in confined areas in two positions (intermediate and full retraction).

The three outrigger positions are:

- Full extension – 20' 6" (6.25 m)
- Intermediate position – 14' 1.75" (4.31 m)
- Full retraction – 7' 9" (2.36 m)
- Capacities are available with the outrigger beams in the intermediate and full retraction positions.
- When the outrigger position levers (located on the outrigger beams) are engaged, the operator can set the crane in the intermediate or full retraction outrigger position without having to leave the cab.

Carrier Cab

- One-man cab of laminated fibrous composite material acoustical insulation with cloth covering. Equipped with:
- Air-ride, six-way adjustable operator's seat.
- Four-way adjustable tilting and lockable steering wheel.
- Door and windows locks
- Left-hand and right-hand rear view mirrors.
- Sliding right-hand and rear tinted windows.
- Roll up/down left-hand tinted window.
- Desiccant-type air dryer
- Steps to upper, lower cab and rear carrier
- 110-volt electric engine block heater
- Back-up warning alarm
- Tow hooks and shackles
- Aluminum fenders with ground control outriggers.
- Electric windshield wiper and washer
- Travel lights
- Fire extinguisher
- 36,000 BTU heater
- Dome light
- Mud flaps
- Horn
- Ashtray
- Defroster
- Cruise control

Optional

- Air conditioning
- Amber strobe light
- Rotating beacon

Cab instrumentation

- Illuminated instrument panel speedometer.
- Tachometer
- Fuel gauge
- Oil pressure gauge
- Turn signal indicator
- Water temperature gauge
- Front and rear air pressure gauges
- Audio/visual warning system
- Automotive type ignition
- Hourmeter
- Fuses
- Odometer
- Voltmeter

Carrier Speeds (Manual Transmission – Standard tires)

Gear	High				Low				Deep reduction		Hi rev.	Lo rev.	Deep reduction	Deep reduction @ 700 rpm	Deep reduction @ 700 rpm		
	8	7	6	5	4	3	2	1	Low	LL2	LL1	Rev	Rev	Rev.	LL1	Low	
Ratio	0.73	1.00	1.38	1.95	2.77	3.79	5.23	7.41	16.30	11.85	26.08	3.43	13.03	20.85	26.08	20.85	
Speed	mph	58.20	42.49	30.79	21.79	15.34	11.21	8.12	5.73	2.61	3.59	1.63	12.13	3.19	1.99	0.55	0.66
	km/hr.	93.65	68.36	49.54	35.06	24.68	18.04	13.07	9.23	4.19	5.77	2.62	19.52	5.13	3.20	0.88	1.06

Engine

Engine – standard	Detroit Diesel, Series 50 8.5 L	Engine – optional	Detroit Diesel, Series 60 12.7 L
Cylinders – cycle	6 / 4	Cylinders – cycle	6 / 4
Bore	5.12" (0.13 m)	Bore	5.12" (0.13 m)
Stroke	6.30" (0.16 m)	Stroke	6.30" (0.16 m)
Displacement	519 cu. in. (8 506 cm ³)	Displacement	778 cu. in. (12 751 cm ³)
Maximum brake hp.	315 @ 1,800 rpm; 315 @ 2,100 rpm	Maximum brake hp.	365 @ 1,800 rpm; 350 @ 2,100 rpm
Peak torque	1,150 ft. lbs. (1 560 J) @ 1,200 rpm	Peak torque	1,350 ft. lbs. (1 831 J) @ 1,200 rpm
Electric system	12-volt neg. ground / 12-volt starting	Electric system	12-volt neg. ground / 12 volt starting
Fuel capacity	100 gallons (378.5 L)	Fuel capacity	100 gallons (378.5 L)
Alternator	12 volt, 130 amps	Alternator	12 volt, 130 amps
Crankcase capacity	22 qts. (21 L)	Crankcase capacity	32 qts. (30 L)
		• Engine brake – standard	• Ether injection starting package – optional

Axle Loads

Base machine with standard 35.5' – 110' (10.82 – 33.53 m) four-section boom, 2M main winch with 2-speed hoisting and power up/down, 600' (182.88 m), 3/4" (19 mm) wire rope, 8 x 4, 8.5' (2.59 m) carrier with Detroit Diesel Series 50 8.5 L engine, 100 gal. (378.5 L) fuel, steel fenders and 5,000 lb. (2 268 kg.) counterweight.	G.V.W. ¹		Upper Facing Front			
			Front Axle		Rear Axle	
		lbs.	kg.	lbs.	kg.	lbs.
	75,008	34 024	32,004	14 517	43,004	19 507
Aluminum fenders with ground control outriggers	-268	-121	-99	-45	-169	-76
Tow shackles – front and rear	56	25	32	15	24	10
Carrier aluminum storage box	57	26	16	7	41	19
Detroit Diesel Series 50 engine S/A with Jake brake	50	23	51	23	-1	-0.5
Detroit Diesel Series 60 engine S/A with Jake brake	459	208	514	233	-55	-25
Engine block heater – propane	83	38	105	48	-22	-10
Ether injection	6	3	6	3	0	0
Tire and steel disc wheels (445/65R22.5 fronts – 12R22.5 rears)	255	116	126	57	129	59
Tire and steel aluminum wheels (425/65R22.5 fronts – 12R22.5 rears)	-425	-193	-222	-101	-203	-92
Air conditioning – Carrier cab	124	56	158	71	-34	-15
Pintle hook	25	11	-10	-5	35	16
Electrical and air electrical hook-ups for dolly or trailer	7	3	0	0	7	3
Driver in carrier cab	200	91	252	114	-52	-23
Cab heater assembly w/fuel (diesel)	49	22	9	4	40	18
Cab heater assembly (hydraulic)	129	59	2	1	127	57
Cab air conditioning	264	120	1	0.5	263	119
Counterweight removal system	176	79	-86	-39	262	118
One slab of counterweight on upper	3,000	1 361	-1,572	-713	4,572	2 074
Two slabs of counterweight on upper	6,000	2 722	-3,143	-1 425	9,143	4 147
Rear winch roller	93	42	-44	-20	137	62
Winch with two speeds and 600' (182.88 m) of wire rope	712	323	-197	-89	909	412
Front winch roller	93	42	-31	-14	124	56
Remove 600' (182.88 m) of rope from rear winch	-660	-299	279	127	-939	-426
Remove 600' (182.88 m) of rope from front winch	-660	-299	185	84	-845	-383
Boom float kit	56	25	14	6	42	19
Add fly brackets to boom base section fly options	160	73	141	64	19	9
Add 34' (10.36 m) offsettable fly w/ATB weight (stowed)	1,478	670	1,456	660	22	10
Add 34' – 56' (10.36 – 17.07 m) offsettable fly w/ATB weight (stowed)	2,134	968	1,857	842	277	126
Add floodlight to front of boom base section	10	5	16	7	-6	-2
Add 40-ton (36.43 mt) hookblock stowed behind bumper (4-sheaves)	720	327	1,201	545	-481	-218
Add 50-ton (45.36 mt) hookblock stowed behind bumper (5-sheaves)	1,109	503	1,850	839	-741	-336
Add hookball to front bumper	360	163	600	272	-240	-109
Add auxiliary arm w/ATB switch to boomhead	95	43	200	91	-105	-48
	G.V.W.		Front Axle		Rear Axle	
Transfer one slab of counterweight to carrier deck	74,613	33 844	3,951	1 792	-3,951	-1 792
Transfer two slabs of counterweight to carrier deck	74,613	33 844	7,902	3 584	-7,902	-3 584

¹ Adjust gross vehicle weight & axle loading according to component weight. Note: All weights are ± 3%

Axle	Max. Load @ 65 mph. (105 km/h)
Front	45,400 lbs. (20 593 kg) – aluminum disc wheels with 425/65R22.5 tires
Front	46,400 lbs. (21 047 kg) – steel disc wheels with 445/65R22.5 tires
Rear	50,350 lbs. (22 838 kg.) – aluminum or steel disc wheels