

# Technical Data

## Specifications & Capacities

# HTC 8675

**LB**  
Telescopic Boom Truck Crane  
75 ton (68.0 metric ton)

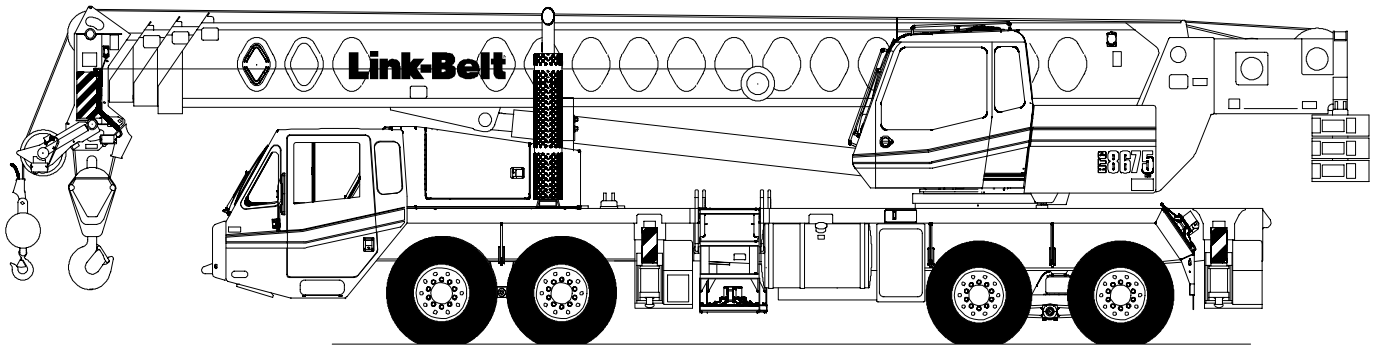

**CAUTION:** This material is supplied for reference use only. Operator must refer to in-cab Crane Rating Manual and Operator's Manual to determine allowable crane lifting capacities and assembly and operating procedures.



# Table Of Contents

<b>Boom, Attachments, and Upper Structure</b> .....	<b>1</b>
Boom .....	1
Boom Head .....	1
Boom Elevation .....	1
Auxiliary Lifting Sheave – Optional .....	1
Hook Blocks and Balls – Optional .....	1
Fly – Optional .....	1
Upper Operator’s Cab and Controls .....	1
Swing .....	2
Electrical .....	2
Load Hoist System .....	2
Load Hoist Performance .....	2
2M Main and Optional Auxiliary Winches .....	3
Hydraulic System .....	3
Counterweight .....	3
<b>Carrier</b> .....	<b>4</b>
General .....	4
Outriggers .....	4
Steering and Axles .....	4
Suspension .....	4
Tires and Wheels .....	4
Brakes .....	4
Electrical .....	4
Engine .....	4
Transmission .....	4
Carrier Speeds and Gradeability .....	5
Fuel Tank .....	5
Hydraulic System .....	5
Pump Drive .....	5
Lower Cab and Controls .....	5
Additional Equipment .....	6
<b>Axle Loads</b> .....	<b>7</b>
<b>Axle Loads with 2–Axle Boom Dolly</b> .....	<b>8</b>
<b>General Dimensions</b> .....	<b>9</b>
<b>Working Range Diagram</b> .....	<b>10</b>
<b>Boom Extend Modes</b> .....	<b>11</b>
<b>Main Boom Lift Capacity Charts – Standard</b> .....	<b>12</b>
12,000 lb Counterweight – Fully Extended Outriggers – 360° Rotation .....	12
12,000 lb Counterweight – On Tires – Stationary – Boom Centered Over Rear .....	13
12,000 lb Counterweight – On Tires – Pick & Carry (1 mph) – Boom Centered Over Rear .....	13

<b>Main Boom Lift Capacity Charts – Optional</b> .....	<b>14</b>
16,000 lb Counterweight – Fully Extended Outriggers – 360° Rotation .....	14
16,000 lb Counterweight – On Tires – Stationary – Boom Centered Over Rear .....	15
16,000 lb Counterweight – On Tires – Pick & Carry (1 mph) – Boom Centered Over Rear .....	15
<b>Fly Attachment Lift Capacity Charts – Optional</b> .....	<b>16</b>
12,000 lb Counterweight – Fully Extended Outriggers – 360° Rotation .....	16
127 ft Main Boom Length – 2° Fly Offset .....	16
127 ft Main Boom Length – 20° Fly Offset .....	16
127 ft Main Boom Length – 40° Fly Offset .....	16
16,000 lb Counterweight – Fully Extended Outriggers – 360° Rotation .....	17
127 ft Main Boom Length – 2° Fly Offset .....	17
127 ft Main Boom Length – 20° Fly Offset .....	17
127 ft Main Boom Length – 40° Fly Offset .....	17
<b>Main Boom Lift Capacity Charts – Optional (Metric)</b> .....	<b>18</b>
5 445kg Counterweight – Fully Extended Outriggers – 360° Rotation .....	18
5 445kg Counterweight – On Tires – Stationary – Boom Centered Over Rear .....	19
5 445kg Counterweight – On Tires – Pick & Carry (1.6km/h) – Boom Centered Over Rear .....	19
<b>Main Boom Lift Capacity Charts – Optional (Metric)</b> .....	<b>20</b>
7 260kg Counterweight – Fully Extended Outriggers – 360° Rotation .....	20
7 260kg Counterweight – On Tires – Stationary – Boom Centered Over Rear .....	21
7 260kg Counterweight – On Tires – Pick & Carry (1.6km/h) – Boom Centered Over Rear .....	21
<b>Fly Attachment Lift Capacity Charts – Optional (Metric)</b> .....	<b>22</b>
5 445kg Counterweight – Fully Extended Outriggers – 360° Rotation .....	22
38.71m Main Boom Length – 2° Fly Offset .....	22
38.71m Main Boom Length – 20° Fly Offset .....	22
38.71m Main Boom Length – 40° Fly Offset .....	22
7 260kg Counterweight – Fully Extended Outriggers – 360° Rotation .....	23
38.71m Main Boom Length – 2° Fly Offset .....	23
38.71m Main Boom Length – 20° Fly Offset .....	23
38.71m Main Boom Length – 40° Fly Offset .....	23

# Boom, Attachments, and Upper Structure

## ■ Boom

**Design** – Four section, box type construction of high tensile steel consisting of one base section and three telescoping sections. The vertical side plates have diamond shaped steel impressions for superior strength to weight ration. The first telescoping section extends independently by means of one double-acting, single stage hydraulic cylinder with integrated holding valves. The second and third telescoping sections extend proportionally by means of one double-acting, single stage cylinder with integrated holding valves and cables.

## Boom

- 41–127 ft (12.5–38.7m) four section full power boom
- Two mode boom extension: *A-max* mode provides superior capacities by extending the first telescoping section to 69.6 ft (21.2m). Standard mode synchronizes all the telescoping sections proportionally to 127 ft (38.7m). Controlled from the operator's cab.
- Mechanical boom angle indicator
- Maximum tip height for *A-max* mode is 78 ft (23.8m) and standard mode is 134 ft (40.8m).
- Provisions for boom dolly connection

## Boom Head

- Five 16.5 in (41.9cm) root diameter nylon sheaves to handle up to ten parts of line
- Easily removable wire rope guards
- Rope dead end lugs on each side of the boom head
- Boom head is designed for quick-reeve of the hook block

## Boom Elevation

- One double acting hydraulic cylinder with integral holding valve
- Boom elevation:  $-3^{\circ}$  to  $78^{\circ}$

## Auxiliary Lifting Sheave – Optional

- Single 16.5 in (41.9m) root diameter nylon sheave
- Easily removable wire rope guards
- Does not affect erection of the fly or use of the main head sheaves

## Hook Blocks and Balls – Optional

- 40 ton (36.3mt) 4 sheave quick-reeve hook block with safety latch
- 60 ton (54.4mt) 4 sheave quick-reeve hook block with safety latch
- 75 ton (68.0mt) 5 sheave quick-reeve hook block with safety latch
- 8.5 ton (7.7mt) swivel and non-swivel hook balls with safety latch

## Fly – Optional

- 39 ft 6 in (12.0m) one piece lattice fly, stowable, offsettable to  $2^{\circ}$ ,  $20^{\circ}$ , and  $40^{\circ}$ . Maximum tip height is 172 ft (52.4m).

- 39 ft 6 in–67 ft (12.0–20.4m) two piece bi-fold lattice fly, stowable, offsettable to  $2^{\circ}$ ,  $20^{\circ}$ , and  $40^{\circ}$ . Maximum tip height is 200 ft (61.0m).

## ■ Upper Operator's Cab and Controls

**Environmental Cab** – Fully enclosed, one person cab of galvaneal steel structure with acoustical insulation.

Equipped with:

- Tinted and tempered glass windows
- Extra-large fixed front window with windshield wiper and washer
- Swing up roof window with windshield wiper
- Sliding left side door with large fixed window
- Sliding rear and right side windows for ventilation
- Six way adjustable, cushioned seat with seat belt and storage compartment
- Engine dependent warm-water heater with air ducts for front windshield defroster and cab floor
- Defroster fan for the front window
- Bubble level
- Circulating fan
- Adjustable sun visor
- Dome light
- Cup holder
- Fire extinguisher
- Left side viewing mirror
- Pull-out cabwalk
- Two position travel swing lock

**Air Conditioning – Optional** – Integral with cab heating system utilizing the same ventilation outlets

**Armrest Controls** – Two dual axis hydraulic joystick controllers or optional single axis hydraulic controllers for:

- Swing
- Boom hoist
- Main rear winch
- Auxiliary front winch – optional
- Drum rotation indication
- Drum rotation indicator activation switch
- Winch high/low speed and disable switch(es)
- Counterweight handling switch
- Telescopic override switches
- Warning horn button
- Swing park brake

**Outrigger Controls** – Hand held control box with umbilical cord gives the operator the freedom to view operation while setting the outriggers.

## Foot Controls

- Boom telescope
- Swing brake
- Engine throttle

**Right Front Console** – Controls and indicators for:

- Engine ignition
- Engine throttle lock
- Function disable
- Front windshield wiper and washer
- Cab floodlights
- Warning horn
- Heating controls
- Console dimmer switch
- Bubble level
- 12 volt power connection
- Air conditioning – optional
- Boom floodlight – optional
- Rotating beacon/Strobe light – optional

**Cab Instrumentation** – Ergonomically positioned, analog instrumentation for crane operation including:

- Check and stop engine indicators
- Engine coolant temperature with warning indicator
- Hydraulic oil temperature with warning indicator
- Fuel level with warning indicator
- Tachometer

**Rated Capacity Limiter** – Microguard graphic audio–visual warning system integrated into the dash with anti–two block and function limiter. Operating data available includes:

- Crane configuration
- Boom length and angle
- Boom head height
- Allowed load and % of allowed load
- Boom angle
- Radius of load
- Actual load
- Presetable defined alarms (include):
  - Maximum and minimum boom angles
  - Maximum tip height
  - Maximum boom length
  - Swing left/right positions
  - Operator defined area (imaginary plane)

**Internal RCL Light Bar – Optional** – Visually informs the operator when crane is approaching maximum load capacity with a series of green, yellow, and red lights.

**External RCL Light Bar – Optional** – Visually informs the ground crew when crane is approaching maximum load capacity with a series of green, yellow, and red lights.

## ■ Swing

**Motor/Planetary** – Bi–directional hydraulic swing motor mounted to a planetary reducer for 360° continuous smooth swing at 1.7 rpm.

**Swing Park Brake** – 360°, electric over hydraulic, (spring applied/hydraulic released) multi–disc brake mounted on the speed reducer. Operated by a toggle switch from the operator’s cab.

**Swing Brake** – 360°, foot operated, hydraulic applied disc brake mounted to the speed reducer.

**Swing Lock** – Two–position swing lock (boom over front or rear) operated from the operator’s cab.

**360° Positive Swing Lock – Optional** – Meets New York City requirement.

## ■ Electrical

**Swing Alarm** – Audio warning device signals when the upper is swinging.

### Lights

- Two working lights on front of the cab
- One rotating amber beacon on top of the cab – optional
- One amber strobe beacon on top of the cab – optional
- Boom floodlight – optional

## ■ Load Hoist System

### Load Hoist Performance

**Main (Rear) and Auxiliary (Front) Winches – 3/4 in (19mm) Rope**

Layer	Maximum Line Pull		Normal Line Speed		High Line Speed		Layer		Total	
	lb	kg	ft/min	m/min	ft/min	m/min	ft	m	ft	m
1	16,506	7 487.0	176	53.6	352	107.3	114	34.7	114	34.7
2	15,175	6 883.4	192	58.5	383	116.7	124	37.8	238	72.5
3	14,043	6 369.9	207	63.1	414	126.2	134	40.8	372	113.4
4	13,068	5 927.6	223	68.0	445	135.6	144	43.9	516	157.3
5	12,220	5 543.0	238	72.5	476	145.1	154	46.9	670	204.2

Wire Rope Application		Diameter		Type	Maximum Permissible Load	
		in	mm		lb	kg
Main (Rear) Winch	Standard	3/4	19	18x19 rotation resistant – right regular lay (Type RB)	12,920	5 860.5
	Optional	3/4	19	36x7 rotation resistant – right regular lay (Type ZB)	15,600	7 076.2
Auxiliary (Front) Winch	Standard	3/4	19	18x19 rotation resistant – right regular lay (Type RB)	12,920	5 860.5
	Optional	3/4	19	36x7 rotation resistant – right regular lay (Type ZB)	15,600	7 076.2

## 2M Main and Optional Auxiliary Winches

- Axial piston, full and half displacement (2–speed) motors driven through planetary reduction unit for positive control under all load conditions.
- Combined winch mode merges the hydraulic flow of two pumps for high–speed operation for either the main or auxiliary winch.
- Grooved lagging
- Power up/down mode of operation
- Hoist drum cable follower
- Drum rotation indicator
- Drum diameter: 16 in (40.6cm)
- Rope length:
  - Main: 670 ft (204.2m)
  - Auxiliary: 670 ft (204.2m)
- Maximum rope storage: 834 ft (254.2m)
- Terminator style socket and wedge

## Hydraulic System

**Counterbalance Valves** – All hoist motors, boom extend cylinders, and boom hoist cylinder are equipped with counterbalance valves to provide load lowering and to prevent accidental load drop if hydraulic power is suddenly reduced.

**Hydraulic Oil Cooler** – Remote mounted cooler with hydraulically driven fan removes heat from the hydraulic oil. Located behind the operator's cab.

**Boom Hoist Float Valves (Optional)** – For transporting the boom over the rear of the crane with a boom dolly. Allows hydraulic oil within the boom hoist cylinder to flow between piston side and case side.

**Swing Brake Release** – For transporting the boom over the rear of the crane with a boom dolly. Holds the 360° swing park brake in the released position allowing free rotation of the upper structure.

## Counterweight

**Standard** – Total of 12,000 lb (5 445kg) of total counterweight consisting of three, hydraulically removable 4,000 lb (1 815kg) counterweights with capacities for 0 lb (0kg), 4,000 lb (1 815kg), 8,000 lb (3 630kg), and 12,000 lb (5 445kg) counterweight configurations. Assembled and disassembled by hydraulic cylinders controlled from the left side of the upper structure.

**Optional** – 4,000 lb (1 815kg) in addition to standard counterweight for a total of 16,000 lb (7 260kg)

Counterweight Usage Combinations					
Cwt	Standard				Optional
	0 lb (0kg)	4,000 lb (1 815kg)	8,000 lb (3 630kg)	12,000 lb (5 445kg)	16,000 lb (7 260kg)
1		X	X	X	X
2			X	X	X
3				X	X
4					X

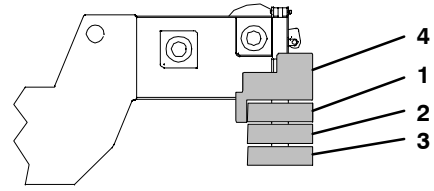

# Carrier

## ■ General

- 8 ft 6 in (2.6 m) wide
- 23 ft 9.2 in (7.24m) wheelbase (centerline of first axle to fourth axle)
- **Frame** – Box–type, torsion resistant, welded construction made of high tensile steel. Equipped with front and rear towing and tie–down lugs, tow connections, and access ladders.

## ■ Outriggers

**Boxes** – Two double box, front and rear welded to the carrier frame

**Beams and Jacks** – Four dual stage beams with Confined Area Lifting Capacities (CALC) provide selectable outrigger extensions of full, intermediate, and retracted positions. Hydraulically controlled from the operator's cab and on both sides of carrier with integral check valves. A fifth front bumper outrigger with integral check valve is hydraulically controlled from the operator's cab and at the front bumper of carrier.

**Pontoons** – Four lightweight, stow'n go, 23.5" x 27.25" (59.7 x 69.2cm) hexagonal steel pontoons with a contact area of 485 in<sup>2</sup> (3 129cm<sup>2</sup>) can be stored for road travel in either the storage racks on the carrier or under the outrigger boxes.

**Main Jack Reaction** – 97,400 lb (44 180.6kg) force and 200.8 psi (1 384.5kPa) ground bearing pressure

## ■ Steering and Axles

- Sheppard full integral master gear/slave gear steering system provides hydraulic assisted steering with mechanical link between steering wheel and wheels
- **Drive** – 8 x 4 for on/off–highway travel
- **Axle 1 & 2** – Tandem steered, non–driven
- **Axle 3 & 4** – Tandem non–steered, driven with reduction: 6.17 to 1
- **Inter–Axle Differential Lock** – Traction adding device that locks axle 3 with axle 4. Operated by a switch from the carrier cab.

## ■ Suspension

**Front** – Four 9–leaf springs with center equalizers

**Rear** – Raydan Air Link walking beam air suspension with height adjustment. The rear of the carrier can be lowered with a switch in the carrier cab.

- **Axle Lift System** – Improves rear tire ground clearance when the crane is up on outriggers.

## ■ Tires and Wheels

**Front** – Four (single) 445/65R22.5 tires on aluminum disc wheels

**Rear** – Eight (dual) 12R22.5 tires on aluminum disc wheels

- Spare tires and wheels – optional
- Tire inflation kit – optional

## ■ Brakes

**Service** – Full air brakes on all wheel ends. Dual circuit compressed air system with air dryer.

**Parking/Emergency** – Spring loaded type, acting on 3rd and 4th axles automatically apply when air pressure drops below 40 psi (275.8kPa) in both circuits.

## ■ Electrical

**Battery** – Four batteries provide 12 volt starting and operation

### Lights

- Front lighting includes two main headlights, two high beam lights, two parking/directional indicators, and three cab marker lights.
- Side lighting includes three parking/directional indicators per side.
- Rear lighting includes two parking/directional indicators, two parking/brake lights, two reverse lights, three marker lights, and a license plate light.
- Other equipment includes hazard/warning system, cab light, instrument panel light, and signal horn.
- One amber strobe beacon on top of the cab – optional
- Daytime running lights – optional

## ■ Engine

Specification	Detroit Diesel Series 60
Numbers of cylinders	6
Cycle	4
Bore and Stroke: inch (mm)	5.12 x 6.30 (130x160)
Piston Displacement: in <sup>3</sup> (L)	778 (12.7)
Max. Brake Horsepower: hp (kW)	378 (281.9) @ 1,800 rpm 375 (279.6) @ 2,100 rpm
Peak Torque: ft lb (J)	1,350 (1 831) @ 1,200 rpm
Alternator: volts – amps	12 – 130
Crankcase Capacity: qt (L)	32 (30.3)
<ul style="list-style-type: none"> <li>• Cruise control</li> <li>• Three–stage engine compression brake</li> <li>• Thermostatically controlled, hydraulically driven radiator fan</li> <li>• 120 volt engine block heater</li> <li>• Ether injection system – optional</li> </ul>	

## ■ Transmission

**Manual** – Eaton RTO–14909ALL has 11 forward gears and 3 reverse gears.



## Carrier Speeds and Gradeability

Eaton		Speed			Gradeability (@ Peak Torque Except Creep @ Idle)
Gear	Ratio	mph	km/h	% Grade	
8th	High Range	.73	58.4	94.0	2.1
7th		1.00	42.6	68.6	3.4
6th		1.38	30.9	49.7	5.1
5th		1.95	21.9	35.2	7.6
Reverse		3.43	12.4	19.8	10.9
4th	Low Range	2.77	15.4	24.8	11.2
3rd		3.79	11.2	18.1	15.6
2nd		5.23	8.2	13.1	21.8
1st		7.41	5.8	9.3	31.1
Low		16.30	2.6	4.2	54.5
Reverse		13.01	3.3	5.2	43.4
LL2	Deep Reduction	11.85	3.6	5.8	50.2
LL1		26.08	1.6	2.6	54.0
Reverse		20.82	2.1	3.3	43.0
LL1 @ 700 rpm		26.08	0.5	0.9	51.2
Reverse @ 700 rpm		20.82	0.7	1.1	40.7

Based on a gross vehicle weight of 95,000 lb (43 091kg)

### Fuel Tank

One 100 gal (378.5L) capacity tank

### Hydraulic System

#### Main Pumps

- Five fixed displacement gear pumps for the main outriggers, main and auxiliary winches, swing, boom hoist, and telescope with manual disconnect for use when crane is in travel mode
- One fixed displacement gear pump for steering and the fifth front bumper outrigger
- One variable displacement piston pump for the controls circuit
- One fixed displacement gear pump for engine cooling fan
- Combined pump capacity of 195 gpm (738.2Lpm)

**Hydraulic Reservoir** – 169 gal (639.7L) capacity equipped with sight level gauge. Diffusers built in for deaeration.

**Filtration** – One 10 micron, full flow, return line filter. All oil is filtered prior to return to reservoir. Accessible for easy filter replacement.

### Pump Drive

All functions are hydraulically powered allowing positive, precise control with independent or simultaneous operation of all functions.

### Lower Cab and Controls

**Environmental Ultra–Cab** – Fully enclosed, one person cab of composite structure with acoustical insulation.

Equipped with:

- Tinted and tempered glass windows
- Roll down left side window for ventilation
- Sliding rear and right side windows for ventilation
- Windshield wiper and washer
- Six way adjustable and air suspended driver's seat with seat belt
- Two adjustable rear view mirrors
- Engine dependent warm–water heater with air ducts for windshield defroster and cab floor
- Adjustable sun visor
- Dome light
- 12 volt connection
- Fire extinguisher
- **Air conditioning – optional** – Integral with cab heating system utilizing the same ventilation outlets.

**Cab Instrumentation** – Ergonomically positioned analog instrumentation for driving including:

- Speedometer with odometer, hourmeter, trip odometer, and clock
- Front and rear air pressure with warning indicator
- Engine coolant temperature with warning indicator
- Engine oil pressure with warning indicator
- Voltage indicator with warning indicator
- Fuel level
- Tachometer

**Right Side Console – Controls For:**

- Transmission gear shifting
- Cruise control
- Engine compression brake

**Dash Mounted Controls For:**

- Check and stop engine indicators
- Windshield wipers and washers
- Carrier lights and turn indicators
- Carrier/upper throttle control
- Engine cooling fan override
- Cab heater/air conditioning
- Console dimmer switch
- Engine diagnostic switch
- Warning lamps
- Engine ignition

**Dash Mounted Indicators For:**

- Check, stop, and service engine
- Turn signal indication
- Park brake
- Cruise activation
- High beam headlights

**Foot Controls For:**

- Carrier service brakes
- Engine throttle
- Transmission clutch

## ■ Additional Equipment

**Standard:**

- Aluminum full deck fenders with mud flaps
- Left and right bubble levels
- Air hose connection ports
- Clearance flags

**Optional:**

- Pneumatic and electrical quick disconnect connectors mounted on the rear for trailer or boom dolly brakes and lights
- Left side aluminum storage box
- Rear mounted pintle hook

# Axle Loads

Base crane with full tank of fuel and no counterweight	Gross Vehicle Weight <sup>(1)</sup>		Front Axles		Rear Axles	
	lb	kg	lb	kg	lb	kg
	78,113	35 432	37,343	16 939	40,770	18 493
Driver in the carrier cab	250	113	315	143	-65	-30
Rear pintle hook	25	11	-11	-5	36	16
Pneumatic and electrical connectors for trailer or boom dolly	7	3	-3	-1	10	5
Carrier aluminum storage box	57	26	16	7	41	19
Ether injection	13	6	12	5	1	0.5
Air conditioning – carrier cab	42	19	51	23	-9	-4
Auxiliary winch with 670 ft (204.2m) of 3/4 in (19mm) type “RB” rope	899	408	-290	-132	1,189	539
Remove 670 ft (204.2m) of rope – main winch	-746	-338	359	163	-1,105	-501
Remove 670 ft (204.2m) of rope – auxiliary winch	-746	-338	270	122	-1,016	-461
Air conditioning – upper operator’s cab	120	54	-4	-2	124	56
360° mechanical swing lock	140	64	22	10	118	54
One slab of counterweight on upper	4,000	1 815	-2,094	-950	6,094	2 764
Two slabs of counterweight on upper	8,000	3 630	-4,187	-1 899	12,187	5 528
Three slabs of counterweight on upper	12,000	5 445	-6,281	-2 849	18,281	8 292
Three slabs and two cheek weights of counterweight on upper	16,000	7 260	-8,374	-3 798	24,374	11 056
Floodlight to the front of the boom base section	10	5	17	8	-7	-3
Fly mounting brackets to boom base section for fly options	160	73	148	67	12	5
39.5 ft (12.0m) offsettable lattice fly – stowed	1,602	727	1,538	698	64	29
39.5–67 ft (12.0–20.4m) offsettable lattice fly – stowed	2,380	1 080	1,995	905	385	175
Auxiliary lifting sheave	125	57	228	103	-103	-47
40 ton (36.3mt) 4 sheave hook block at front bumper	720	327	1,163	528	-443	-201
60 ton (54.4mt) 4 sheave hook block at front bumper	1,109	503	1,791	812	-682	-309
75 ton (68.0mt) 5 sheave hook block at front bumper	1,400	635	2,261	1 026	-861	-391
8.5 ton (7.7mt) hook ball at front bumper	360	163	581	264	-221	-100

Counterweight Load Transfer	Front Axles		Rear Axles	
	lb	kg	lb	kg
Transfer one slab of counterweight to carrier deck	5,264	2 388	-5,264	-2 388
Transfer two slabs of counterweight to carrier deck	10,528	4 775	-10,528	-4 775
Transfer three slabs of counterweight to carrier deck	15,792	7 163	-15,792	-7 163

Axle	Maximum Load @ 65 mph (105km/h)
Front	46,400 lb (21 047kg) – aluminum disc wheels with 445/65R22.5 tires
Rear	50,350 lb (22 838kg) – aluminum disc wheels with 12R22.5 tires

<sup>(1)</sup> Adjust gross vehicle weight and axle loading according to component weight.

Note: All weights are  $\pm 3\%$ .

## Axle Loads with 2–Axle Boom Dolly

Base crane and 5,700 lb (2 585kg) boom dolly with full tank of fuel and no counterweight	Gross Vehicle Weight <sup>(1)</sup>		Front Axles		Rear Axles		Dolly Axles	
	lb	kg	lb	kg	lb	kg	lb	kg
	83,813	38 017	30,898	14 015	34,343	15 578	18,572	8 424
Driver in the carrier cab	250	113	315	143	–65	–30	0	0
Rear pintle hook	25	11	–11	–5	36	16	0	0
Pneumatic and electrical connectors for trailer or boom dolly	7	3	–3	–1	10	5	0	0
Carrier aluminum storage box	57	26	16	7	41	19	0	0
Ether injection	13	6	12	5	1	0.5	0	0
Air conditioning – carrier cab	42	19	51	23	–9	–4	0	0
Auxiliary winch with 670 ft (204.2m) of 3/4 in (19mm) type “RB” rope	899	408	621	282	278	126	0	0
Remove 670 ft (204.2m) of rope – main winch	–746	–338	–560	–254	–186	–84	0	0
Remove 670 ft (204.2m) of rope – auxiliary winch	–746	–338	–471	–214	–275	–125	0	0
Air conditioning – upper operator’s cab	120	54	–4	–2	124	56	0	0
360° mechanical swing lock	140	64	16	7	124	56	0	0
One slab of counterweight on carrier deck	4,000	1 815	3,171	1 438	829	376	0	0
Two slabs of counterweight on carrier deck	8,000	3 630	6,341	2 876	1,659	753	0	0
Three slabs of counterweight on carrier deck	12,000	5 445	9,512	4 315	2,488	1 129	0	0
Three slabs and two cheek weights of counterweight on carrier deck	16,000	7 260	12,682	5 752	3,318	1 505	0	0
Floodlight to the front of the boom base section	10	5	–1	–0.5	–1	–0.5	11	5
Fly mounting brackets to boom base section for fly options	160	73	26	12	26	12	108	49
39.5 ft (12.0m) offsettable lattice fly – stowed	1,602	727	239	108	241	109	1,123	509
39.5–67 ft (12.0–20.4m) offsettable lattice fly – stowed	2,380	1 080	447	203	450	204	1,484	673
Auxiliary lifting sheave	125	57	–18	–8	–18	–8	162	73
40 ton (36.3mt) 4 sheave hook block at front bumper	720	327	–89	–40	–89	–40	898	407
60 ton (54.4mt) 4 sheave hook block at front bumper	1,109	503	–136	–62	–137	–62	1,383	627
75 ton (68.0mt) 5 sheave hook block at front bumper	1,400	635	–172	–78	–173	–78	1,745	792
8.5 ton (7.7mt) hook ball at front bumper	360	163	–52	–24	–53	–24	465	211

Counterweight Load Transfer	Front Axles		Rear Axles		Dolly Axles	
	lb	kg	lb	kg	lb	kg
Transfer two slabs of counterweight to boom dolly	–6,341	–2 876	–1,659	753	8,000	3 629

(<sup>1</sup>) Adjust gross vehicle weight and axle loading according to component weight.  
 Note: All weights are ±3%.

# General Dimensions

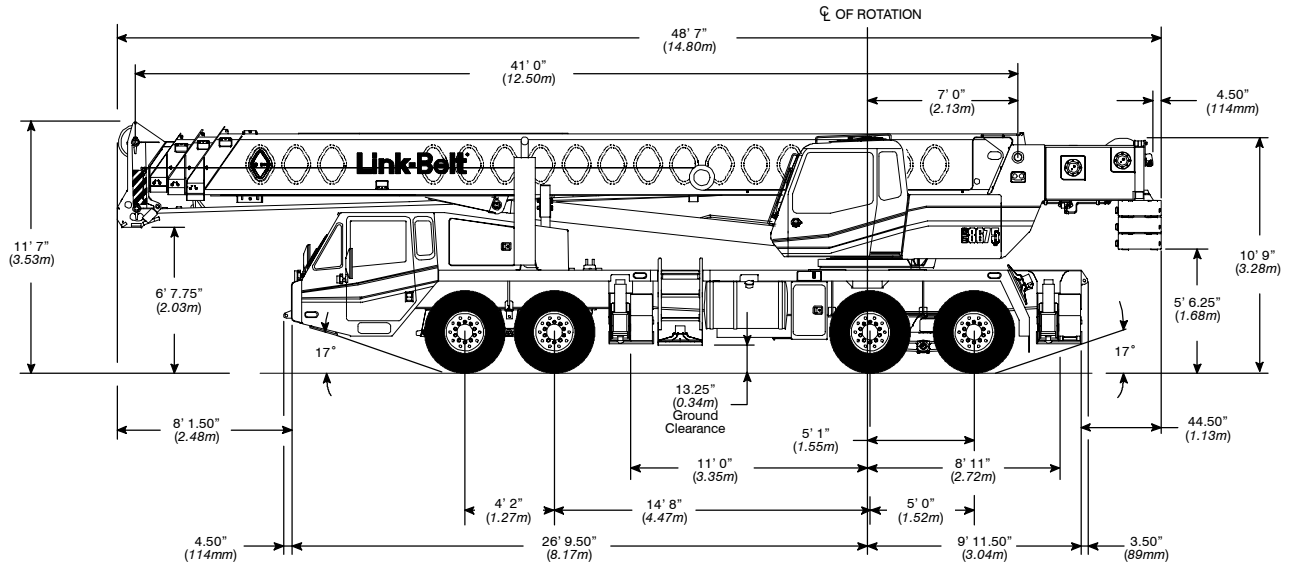

Turning Radius	English	Metric
Wall to wall over carrier	46' 3"	14.1m
Wall to wall over boom	49' 4"	15.0m
Wall to wall over boom attachment	51' 3"	15.6m
Curb to curb	41' 10"	12.8m
Centerline of tire	41' 1"	12.5m

Tail Swing	English	Metric
With counterweight	13' 8"	4.2m
Without counterweight	13' 1"	4.0m

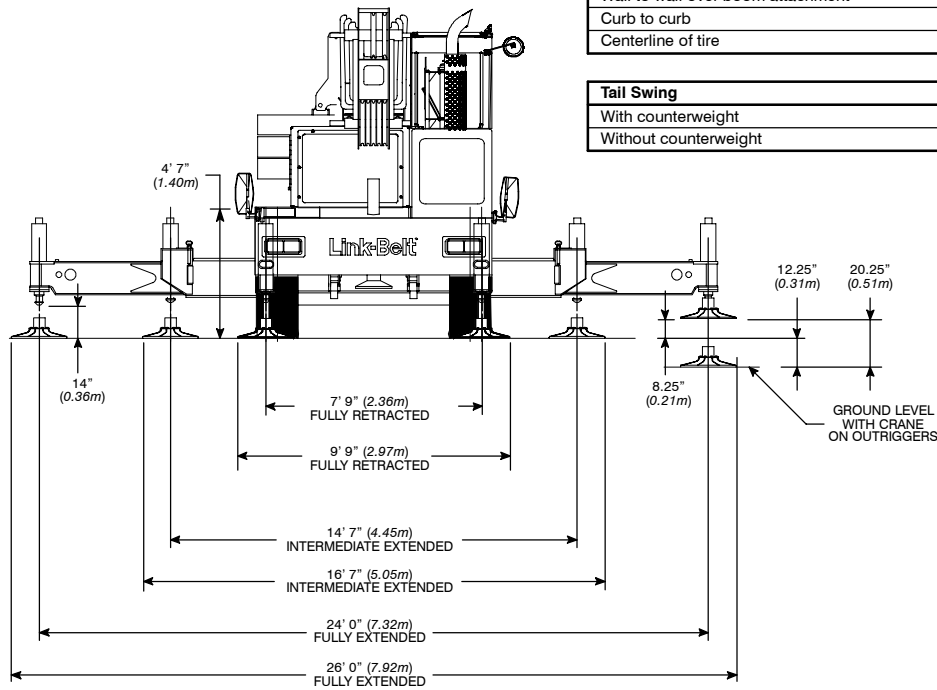

Not To Scale

# Working Range Diagram

**12,000 lb (5 445kg)  
Counterweight**

**Working Range Diagram  
On Fully Extended Outriggers**

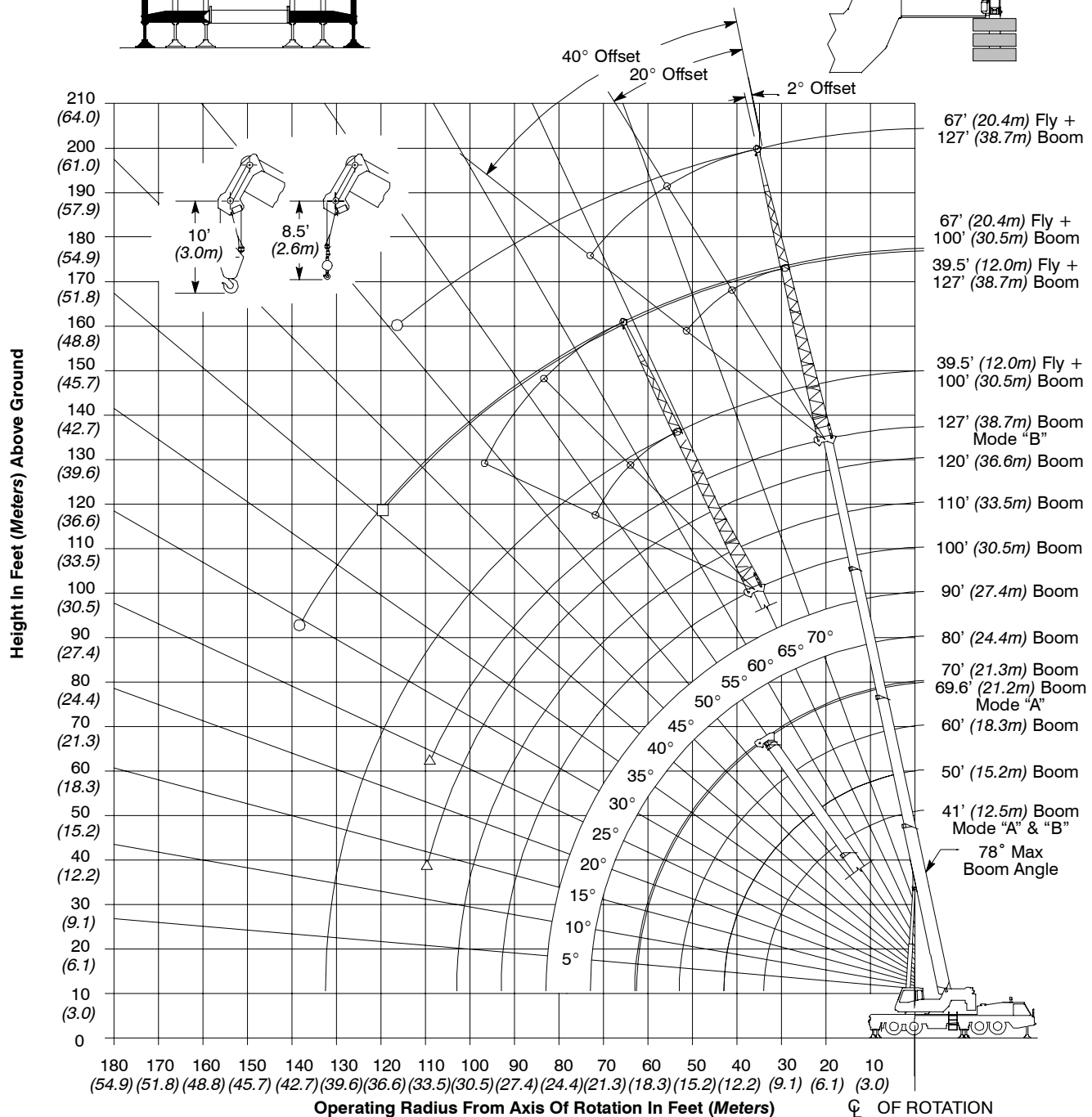
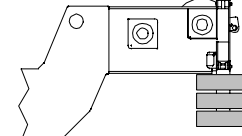
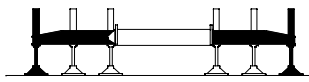

- Denotes Main Boom + 67' (20.4m) Fly – Boom Mode "B"
- Denotes Main Boom + 39.5' (12.0m) Fly – Boom Mode "B"
- △ Denotes Main Boom – Boom Mode "B"

# Boom Extend Modes

## Boom Mode “A” (A-max)

Only inner mid section telescopes.

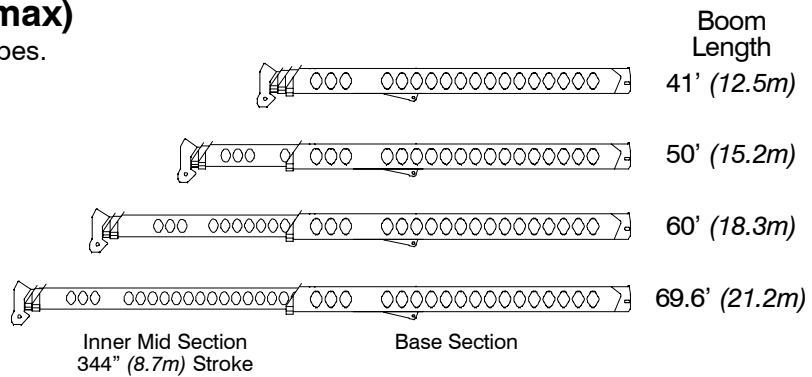

## Boom Mode “B” (Standard)

Inner mid, outer mid, and tip sections telescope simultaneously.

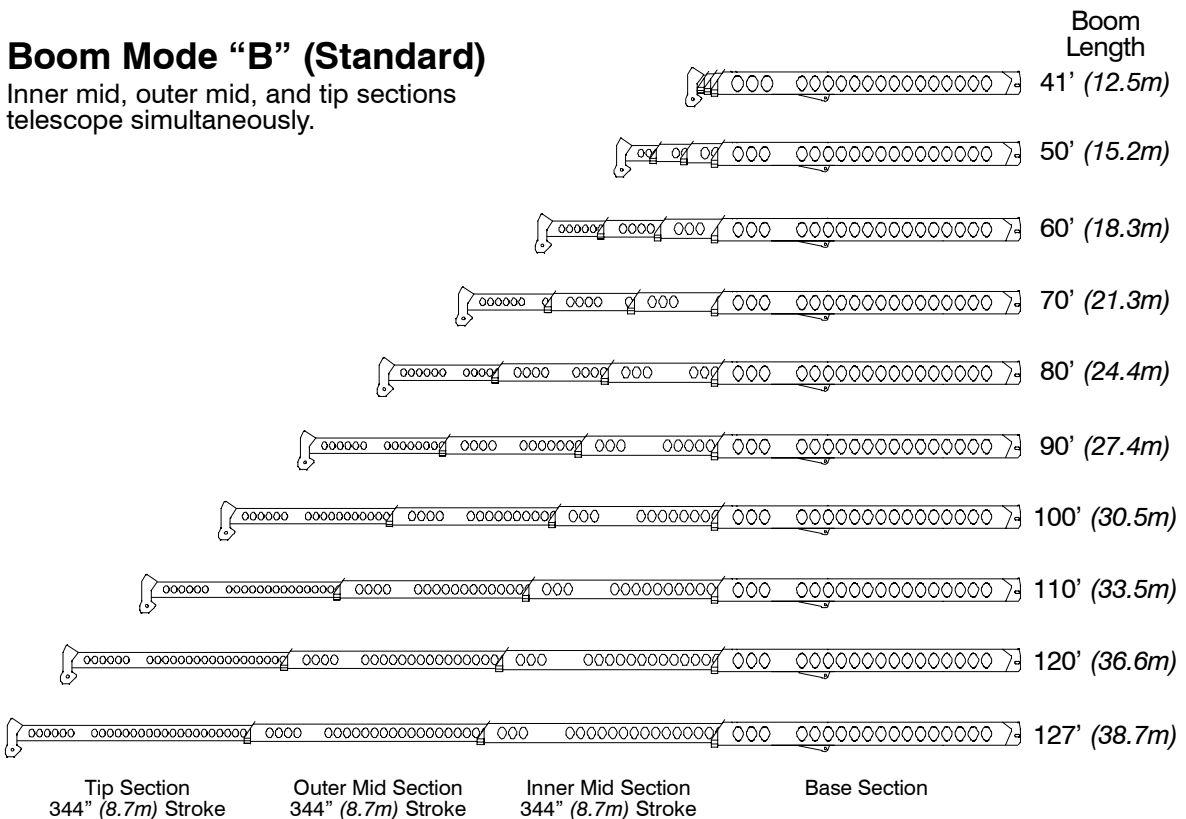

# Main Boom Lift Capacity Charts – Standard

12,000 lb Counterweight – Fully Extended Outriggers – 360° Rotation (All Capacities Are Listed In Pounds)											
Radius (ft)	Boom Length (ft)										Radius (ft)
	41	50	60	69.6/70	80	90	100	110	120	127	
8	150,000*										8
9	140,000*										9
10	127,500	75,100	74,000								10
12	113,600	75,100	74,000	43,900**							12
15	97,300	75,100	74,000	43,900**	38,000						15
20	73,100	72,500	72,000	43,900**	38,000	38,000	37,400				20
25	56,100	55,600	55,200	43,900**	38,000	38,000	32,700	29,400	23,300	19,600	25
30	41,900	41,300	40,600	38,000	38,000	37,900	29,000	26,200	23,300	19,600	30
35		32,800	33,300	33,600	33,800	33,900	26,000	23,500	21,500	19,600	35
40		25,800	26,500	26,800	27,000	27,200	23,400	21,200	19,400	18,400	40
45			21,500	21,900	22,200	22,300	21,200	19,200	17,600	16,400	45
50			17,700	18,200	18,400	18,600	18,700	17,400	15,800	14,900	50
55				15,200	15,500	15,600	15,800	15,800	14,400	13,600	55
60				12,800	13,100	13,300	13,400	13,500	13,200	12,500	60
65					11,200	11,400	11,500	11,600	11,700	11,500	65
70					9,500	9,700	9,800	9,900	10,000	10,000	70
75						8,300	8,400	8,500	8,600	8,600	75
80						7,000	7,200	7,300	7,300	7,400	80
85							6,100	6,200	6,300	6,300	85
90							5,200	5,300	5,400	5,400	90
95								4,500	4,600	4,600	95
100								3,700	3,800	3,900	100
105									3,200	3,200	105
110									2,600	2,700	110

\* Special Conditions Or Wire Rope Required  
 \*\* 63.6 A –max Mode

This information is not for crane operation. Operator must refer to the in-cab information for crane operation. Rated lifting capacities shown on fully extended outriggers do not exceed 85% of the tipping loads and on tires do not exceed 75% of the tipping loads.



**12,000 lb Counterweight – On Tires – Stationary – Boom Centered Over Rear**  
(All Capacities Are Listed In Pounds)

Radius (ft)	Boom Length (ft)						Radius (ft)
	41	50	60	70	80	90	
10	31,700						10
12	28,700						12
15	24,900	25,300					15
20	19,800	20,200					20
25	15,900	16,400	16,700				25
30	12,500	13,200	13,700	14,000			30
35		9,900	10,400	10,700	11,000		35
40		7,300	7,900	8,200	8,400	8,600	40
45			5,900	6,300	6,500	6,700	45
50			4,400	4,700	5,000	5,200	50
55				3,500	3,800	3,900	55
60					2,700	2,900	60

**12,000 lb Counterweight – On Tires – Pick & Carry (1 mph) – Boom Centered Over Rear**  
(All Capacities Are Listed In Pounds)

Radius (ft)	Boom Length (ft)						Radius (ft)
	41	50	60	70	80	90	
10	22,600						10
12	20,500						12
15	17,400	17,800					15
20	13,300	13,800					20
25	10,200	10,800	11,100				25
30	7,800	8,300	8,700	9,000			30
35		6,400	6,800	7,100	7,300		35
40		4,700	5,200	5,500	5,700	5,900	40
45			3,900	4,200	4,400	4,600	45
50			2,700	3,000	3,300	3,400	50
55				2,100	2,300	2,500	55
60					1,500	1,600	60

This information is not for crane operation. Operator must refer to the in-cab information for crane operation. Rated lifting capacities shown on fully extended outriggers do not exceed 85% of the tipping loads and on tires do not exceed 75% of the tipping loads.

# Main Boom Lift Capacity Charts – Optional

16,000 lb Counterweight – Fully Extended Outriggers – 360° Rotation (All Capacities Are Listed In Pounds)											
Radius (ft)	Boom Length (ft)										Radius (ft)
	41	50	60	69.6/70	80	90	100	110	120	127	
8	150,000*										8
9	140,000*										9
10	128,600	75,100	74,000								10
12	116,000	75,100	74,000	43,900**							12
15	99,400	75,100	74,000	43,900**	38,000						15
20	75,300	74,700	74,000	43,900**	38,000	38,000	37,400				20
25	58,100	57,600	57,200	43,900**	38,000	38,000	32,700	29,400	23,300	19,600	25
30	45,300	44,700	44,100	38,000	38,000	37,900	29,000	26,200	23,300	19,600	30
35		35,600	36,100	36,400	36,600	33,900	26,000	23,500	21,500	19,600	35
40		28,200	28,900	29,200	29,400	29,500	23,400	21,200	19,400	18,400	40
45			23,600	24,000	24,200	24,300	21,200	19,200	17,600	16,400	45
50			19,500	20,000	20,200	20,400	19,300	17,400	15,800	14,900	50
55				16,800	17,100	17,200	17,300	15,800	14,400	13,600	55
60				14,200	14,500	14,700	14,800	14,500	13,200	12,500	60
65					12,500	12,700	12,800	12,800	12,200	11,500	65
70					10,700	11,000	11,100	11,200	11,200	10,600	70
75						9,500	9,600	9,800	9,800	9,700	75
80						8,200	8,400	8,500	8,600	8,600	80
85							7,200	7,300	7,400	7,500	85
90							6,200	6,400	6,400	6,500	90
95								5,500	5,600	5,600	95
100								4,700	4,800	4,800	100
105									4,100	4,100	105
110									3,500	3,500	110
115									2,900		115

\* Special Conditions Or Wire Rope Required  
 \*\* 63.6 A – max Mode

This information is not for crane operation. Operator must refer to the in-cab information for crane operation. Rated lifting capacities shown on fully extended outriggers do not exceed 85% of the tipping loads and on tires do not exceed 75% of the tipping loads.

**16,000 lb Counterweight – On Tires – Stationary – Boom Centered Over Rear**  
(All Capacities Are Listed In Pounds)

Radius (ft)	Boom Length (ft)						Radius (ft)
	41	50	60	70	80	90	
10	31,700						10
12	28,700						12
15	24,900	25,300					15
20	19,800	20,200					20
25	15,900	16,400	16,700				25
30	12,800	13,400	13,700	14,000			30
35		10,900	11,400	11,700	11,900		35
40		8,500	9,100	9,400	9,700	9,800	40
45			7,000	7,300	7,600	7,800	45
50			5,300	5,700	5,900	6,100	50
55				4,400	4,600	4,800	55
60				3,300	3,500	3,700	60
65					2,600	2,800	65

**16,000 lb Counterweight – On Tires – Pick & Carry (1 mph) – Boom Centered Over Rear**  
(All Capacities Are Listed In Pounds)

Radius (ft)	Boom Length (ft)						Radius (ft)
	41	50	60	70	80	90	
10	20,100						10
12	20,100						12
15	17,400	17,800					15
20	13,300	13,800					20
25	10,200	10,800	11,100				25
30	7,800	8,300	8,700	9,000			30
35		6,400	6,800	7,100	7,300		35
40		4,700	5,200	5,500	5,700	5,900	40
45			3,900	4,200	4,400	4,600	45
50			2,700	3,000	3,300	3,400	50
55				2,100	2,300	2,500	55
60				1,200	1,500	1,600	60
65					700	900	65

This information is not for crane operation. Operator must refer to the in-cab information for crane operation. Rated lifting capacities shown on fully extended outriggers do not exceed 85% of the tipping loads and on tires do not exceed 75% of the tipping loads.

# Fly Attachment Lift Capacity Charts – Optional

12,000 lb Counterweight – Fully Extended Outriggers – 360° Rotation (All Capacities Are Listed In Pounds)								
127 ft Main Boom Length 2° Fly Offset			127 ft Main Boom Length 20° Fly Offset			127 ft Main Boom Length 40° Fly Offset		
Radius (ft)	Fly Length (ft)		Radius (ft)	Fly Length (ft)		Radius (ft)	Fly Length (ft)	
	39.5	67		39.5	67		39.5	67
35	8,300		50	8,200		65	6,200	
40	8,300		55	8,000		70	6,100	
45	8,300		60	7,800		75	6,000	
50	8,300	5,500	65	7,600		80	5,800	
55	8,300	5,500	70	7,400	4,200	85	5,700	
60	8,300	5,500	75	7,200	4,000	90	5,700	2,900
65	8,300	5,500	80	7,000	3,900	95	5,600	2,800
70	8,300	5,500	85	6,800	3,800	100	5,500	2,800
75	7,800	5,300	90	6,300	3,600	105	5,100	2,700
80	7,100	5,100	95	5,800	3,500	110	4,600	2,600
85	6,600	4,900	100	5,300	3,400	115	4,000	2,600
90	6,000	4,800	105	4,900	3,300	120	3,400	2,600
95	5,600	4,600	110	4,200	3,200	125	2,900	2,500
100	4,900	4,300	115	3,600	3,100	130	2,400	2,500
105	4,200	3,900	120	3,100	3,000	135		2,500
110	3,600	3,600	125	2,600	2,900	140		2,300
115	3,100	3,200	130	2,200	2,600	145		2,000
120	2,600	2,900	135		2,300	150		1,800
125		2,700	140		2,100			

This information is not for crane operation. Operator must refer to the in-cab information for crane operation. Rated lifting capacities shown on fully extended outriggers do not exceed 85% of the tipping loads and on tires do not exceed 75% of the tipping loads.

16,000 lb Counterweight – Fully Extended Outriggers – 360° Rotation (All Capacities Are Listed In Pounds)								
127 ft Main Boom Length 2° Fly Offset			127 ft Main Boom Length 20° Fly Offset			127 ft Main Boom Length 40° Fly Offset		
Radius (ft)	Fly Length (ft)		Radius (ft)	Fly Length (ft)		Radius (ft)	Fly Length (ft)	
	39.5	67		39.5	67		39.5	67
35	8,300		50	8,200		65	6,200	
40	8,300		55	8,000		70	6,100	
45	8,300		60	7,800		75	6,000	
50	8,300	5,500	65	7,600		80	5,800	
55	8,300	5,500	70	7,400	4,200	85	5,700	
60	8,300	5,500	75	7,200	4,000	90	5,700	2,900
65	8,300	5,500	80	7,000	3,900	95	5,600	2,800
70	8,300	5,500	85	6,800	3,800	100	5,500	2,800
75	7,800	5,300	90	6,300	3,600	105	5,100	2,700
80	7,100	5,100	95	5,800	3,500	110	4,700	2,600
85	6,600	4,900	100	5,300	3,400	115	4,300	2,600
90	6,000	4,800	105	4,900	3,300	120	4,000	2,600
95	5,600	4,600	110	4,500	3,200	125	3,600	2,500
100	5,100	4,300	115	4,200	3,100	130	3,100	2,500
105	4,700	3,900	120	3,800	3,000	135	2,600	2,500
110	4,300	3,600	125	3,300	2,900	140		2,300
115	3,900	3,200	130	2,900	2,600	145		2,000
120	3,400	2,900	135	2,400	2,300	150		1,800
125	2,900	2,700	140	2,000	2,100	155		1,600
130	2,500	2,400	145		1,900			
135		2,200	150		1,700			

This information is not for crane operation. Operator must refer to the in-cab information for crane operation. Rated lifting capacities shown on fully extended outriggers do not exceed 85% of the tipping loads and on tires do not exceed 75% of the tipping loads.

# Main Boom Lift Capacity Charts – Optional (Metric)

5 445kg Counterweight – Fully Extended Outriggers – 360° Rotation (All Capacities Are Listed In Kilograms)												
Radius (m)	Boom Length (m)										Radius (m)	
	12.5	15.2	18.3	21.21/21.3	24.4	27.4	30.5	33.5	36.6	38.71		
2.44	68 000*											2.44
3.0	58 350	34 050	33 550									3.0
3.5	53 050	34 050	33 550	19 900**								3.5
4.0	48 500	34 050	33 550	19 900**								4.0
4.5	44 650	34 050	33 550	19 900**	17 200							4.5
5.0	41 100	34 050	33 550	19 900**	17 200							5.0
6.0	33 700	33 450	33 250	19 900**	17 200	17 200	17 150					6.0
7.0	27 200	26 800	26 450	19 900**	17 200	17 200	15 700					7.0
8.0	21 300	20 950	20 650	19 150**	17 200	17 200	14 350	12 950	10 550	8 900		8.0
9.0	17 250	17 200	17 200	17 200	17 200	17 200	13 300	12 000	10 550	8 900		9.0
10.0	14 250	14 700	14 850	15 000	15 100	15 150	12 350	11 150	10 200	8 900		10.0
12.0		10 650	10 900	11 050	11 100	11 200	10 750	9 700	8 900	8 450		12.0
14.0			8 300	8 450	8 550	8 600	8 650	8 550	7 800	7 300		14.0
16.0			6 450	6 650	6 750	6 800	6 850	6 850	6 850	6 450		16.0
18.0				5 300	5 450	5 500	5 550	5 600	5 600	5 650		18.0
20.0					4 400	4 450	4 500	4 550	4 550	4 600		20.0
22.0						3 500	3 600	3 650	3 700	3 750		22.0
24.0							2 900	2 950	3 000	3 050		24.0
26.0								2 400	2 450	2 500		26.0
28.0								1 950	2 000	2 050		28.0
30.0									1 600	1 650		30.0
32.0										1 250	1 300	32.0

\* Special Conditions Or Wire Rope Required  
 \*\* 21.21 A – max Mode

This information is not for crane operation. Operator must refer to the in-cab information for crane operation. Rated lifting capacities shown on fully extended outriggers do not exceed 75% of the tipping loads and on tires do not exceed 65% of the tipping loads.

**5 445kg Counterweight – On Tires – Stationary – Boom Centered Over Rear**  
(All Capacities Are Listed In Kilograms)

Radius (m)	Boom Length (m)						Radius (m)
	12.5	15.2	18.3	21.3	24.4	27.4	
3.0	14 500						3.0
3.5	13 350						3.5
4.0	12 300						4.0
4.5	11 400	11 550					4.5
5.0	10 550	10 750					5.0
6.0	9 100	9 300					6.0
7.0	7 850	8 100					7.0
8.0	6 300	6 550	6 750				8.0
9.0	5 050	5 350	5 550	5 700			9.0
10.0	4 100	4 400	4 600	4 750			10.0
12.0		3 000	3 200	3 300	3 400	3 500	12.0
14.0			2 200	2 350	2 400	2 500	14.0
16.0			1 450	1 600	1 700	1 750	16.0
18.0				1 050	1 150	1 200	18.0

**5 445kg Counterweight – On Tires – Pick & Carry (1.6km/h) – Boom Centered Over Rear**  
(All Capacities Are Listed In Kilograms)

Radius (m)	Boom Length (m)						Radius (m)
	12.5	15.2	18.3	21.3	24.4	27.4	
3.0	10 350						3.0
3.5	9 550						3.5
4.0	8 750						4.0
4.5	8 000	8 150					4.5
5.0	7 300	7 500					5.0
6.0	6 150	6 350					6.0
7.0	5 200	5 400					7.0
8.0	4 350	4 600	4 750				8.0
9.0	3 600	3 900	4 050	4 200			9.0
10.0	2 950	3 250	3 450	3 550			10.0
12.0		2 250	2 450	2 550	2 650	2 750	12.0
14.0			1 650	1 800	1 900	1 950	14.0
16.0			1 000	1 150	1 250	1 350	16.0
18.0				600	750	800	18.0

This information is not for crane operation. Operator must refer to the in-cab information for crane operation. Rated lifting capacities shown on fully extended outriggers do not exceed 75% of the tipping loads and on tires do not exceed 65% of the tipping loads.

## Main Boom Lift Capacity Charts – Optional (Metric)

**7 260kg Counterweight – Fully Extended Outriggers – 360° Rotation**  
**(All Capacities Are Listed In Kilograms)**

Radius (m)	Boom Length (m)										Radius (m)	
	12.5	15.2	18.3	21.21/21.3	24.4	27.4	30.5	33.5	36.6	38.71		
2.44	68 000*											2.44
3.0	58 350	34 050	33 550									3.0
3.5	54 150	34 050	33 550	19 900**								3.5
4.0	49 550	34 050	33 550	19 900**								4.0
4.5	45 600	34 050	33 550	19 900**	17 200							4.5
5.0	42 150	34 050	33 550	19 900**	17 200							5.0
6.0	34 750	34 050	33 550	19 900**	17 200	17 200	17 150					6.0
7.0	29 150	28 900	28 550	19 900**	17 200	17 200	15 700					7.0
8.0	23 000	22 650	22 350	19 150**	17 200	17 200	14 350	12 950	10 550	8 900		8.0
9.0	18 650	18 400	18 100	17 400**	17 200	17 200	13 300	12 000	10 550	8 900		9.0
10.0	15 500	15 900	16 100	16 200	16 300	16 100	12 350	11 150	10 200	8 900		10.0
12.0		11 600	11 850	11 950	12 050	12 100	10 750	9 700	8 900	8 450		12.0
14.0			9 100	9 250	9 350	9 400	9 450	8 550	7 800	7 300		14.0
16.0			7 100	7 300	7 400	7 450	7 500	7 500	6 850	6 450		16.0
18.0				5 850	6 000	6 050	6 100	6 150	6 100	5 750		18.0
20.0					4 900	5 000	5 050	5 100	5 100	5 100		20.0
22.0					4 000	4 100	4 200	4 200	4 250	4 250		22.0
24.0						3 400	3 450	3 500	3 550	3 550		24.0
26.0							2 850	2 900	2 950	2 950		26.0
28.0							2 350	2 400	2 400	2 450		28.0
30.0								1 950	2 000	2 000		30.0
32.0									1 650	1 650		32.0
34.0									1 300	1 350		34.0
36.										1 050		36.0

\* Special Conditions Or Wire Rope Required

\*\* 19.39 A – max Mode

This information is not for crane operation. Operator must refer to the in-cab information for crane operation. Rated lifting capacities shown on fully extended outriggers do not exceed 75% of the tipping loads and on tires do not exceed 65% of the tipping loads.



**7 260kg Counterweight – On Tires – Stationary – Boom Centered Over Rear**  
(All Capacities Are Listed In Kilograms)

Radius (m)	Boom Length (m)						Radius (m)
	12.5	15.2	18.3	21.3	24.4	27.4	
3.0	14 500						3.0
3.5	13 350						3.5
4.0	12 300						4.0
4.5	11 400	11 550					4.5
5.0	10 550	10 750					5.0
6.0	9 100	9 300					6.0
7.0	7 850	8 100					7.0
8.0	6 800	7 050	7 200				8.0
9.0	5 750	6 000	6 200	6 350			9.0
10.0	4 700	5 000	5 200	5 350			10.0
12.0		3 450	3 650	3 800	3 900	3 950	12.0
14.0			2 600	2 750	2 850	2 900	14.0
16.0			1 800	1 950	2 050	2 150	16.0
18.0				1 350	1 450	1 500	18.0
20.0						1 050	20.0

**7 260kg Counterweight – On Tires – Pick & Carry (1.6km/h) – Boom Centered Over Rear**  
(All Capacities Are Listed In Kilograms)

Radius (m)	Boom Length (m)						Radius (m)
	12.5	15.2	18.3	21.3	24.4	27.4	
3.0	10 350						3.0
3.5	9 550						3.5
4.0	8 750						4.0
4.5	8 000	8 150					4.5
5.0	7 300	7 500					5.0
6.0	6 150	6 350					6.0
7.0	5 200	5 400					7.0
8.0	4 350	4 600	4 750				8.0
9.0	3 600	3 900	4 050	4 200			9.0
10.0	2 950	3 250	3 450	3 550			10.0
12.0		2 250	2 450	2 550	2 650	2 750	12.0
14.0			1 650	1 800	1 900	1 950	14.0
16.0			1 000	1 150	1 250	1 350	16.0
18.0				600	750	800	18.0
20.0						350	20.0

This information is not for crane operation. Operator must refer to the in-cab information for crane operation. Rated lifting capacities shown on fully extended outriggers do not exceed 75% of the tipping loads and on tires do not exceed 65% of the tipping loads.

## Fly Attachment Lift Capacity Charts – Optional (Metric)

5 445kg Counterweight – Fully Extended Outriggers – 360° Rotation (All Capacities Are Listed In Kilograms)								
38.71m Main Boom Length 2° Fly Offset			38.71m Main Boom Length 20° Fly Offset			38.71m Main Boom Length 40° Fly Offset		
Radius (m)	Fly Length (m)		Radius (m)	Fly Length (m)		Radius (m)	Fly Length (m)	
	12.04	20.42		12.04	20.42		12.04	20.42
12.0	3 750		12.0			12.0		
14.0	3 750		14.0			14.0		
16.0	3 750	2 450	16.0	3 650		16.0		
18.0	3 750	2 450	18.0	3 550		18.0		
20.0	3 750	2 450	20.0	3 400		20.0	2 800	
22.0	3 700	2 450	22.0	3 300	1 850	22.0	2 750	
24.0	3 300	2 350	24.0	3 200	1 800	24.0	2 650	
26.0	2 900	2 250	26.0	3 050	1 700	26.0	2 600	
28.0	2 450	2 150	28.0	2 750	1 600	28.0	2 550	1 300
30.0	2 050	2 000	30.0	2 300	1 550	30.0	2 500	1 250
32.0	1 700	1 800	32.0	1 950	1 500	32.0	2 150	1 200
34.0	1 350	1 550	34.0	1 600	1 450	34.0	1 750	1 200
36.0	1 100	1 350	36.0	1 300	1 400	36.0	1 450	1 150
38.0		1 100	38.0	1 050	1 300	38.0	1 150	1 150
40.0			40.0	800	1 150	40.0	900	1 150
42.0			42.0		950	42.0		1 100
44.0			44.0			44.0		900

This information is not for crane operation. Operator must refer to the in-cab information for crane operation. Rated lifting capacities shown on fully extended outriggers do not exceed 75% of the tipping loads and on tires do not exceed 65% of the tipping loads.

7 260kg Counterweight – Fully Extended Outriggers – 360° Rotation (All Capacities Are Listed In Kilograms)								
38.71m Main Boom Length 2° Fly Offset			38.71m Main Boom Length 20° Fly Offset			38.71m Main Boom Length 40° Fly Offset		
Radius (ft)	Fly Length (m)		Radius (m)	Fly Length (m)		Radius (m)	Fly Length (m)	
	12.04	20.42		12.04	20.42		12.04	20.42
12.0	3 750		12.0			12.0		
14.0	3 750		14.0			14.0		
16.0	3 750	2 450	16.0	3 650		16.0		
18.0	3 750	2 450	18.0	3 550		18.0		
20.0	3 750	2 450	20.0	3 400		20.0	2 800	
22.0	3 700	2 450	22.0	3 300	1 850	22.0	2 750	
24.0	3 300	2 350	24.0	3 200	1 800	24.0	2 650	
26.0	2 950	2 250	26.0	3 050	1 700	26.0	2 600	
28.0	2 650	2 150	28.0	2 750	1 600	28.0	2 550	1 300
30.0	2 400	2 000	30.0	2 500	1 550	30.0	2 500	1 250
32.0	2 050	1 800	32.0	2 250	1 500	32.0	2 300	1 200
34.0	1 700	1 550	34.0	1 950	1 450	34.0	2 050	1 200
36.0	1 400	1 400	36.0	1 600	1 400	36.0	1 750	1 150
38.0	1 150	1 200	38.0	1 350	1 300	38.0	1 450	1 150
40.0	950	1 050	40.0	1 100	1 150	40.0	1 150	1 150
42.0		900	42.0	850	1 000	42.0	900	1 100
44.0			44.0		850	44.0		950
46.0			46.0		750	46.0		800

This information is not for crane operation. Operator must refer to the in-cab information for crane operation. Rated lifting capacities shown on fully extended outriggers do not exceed 75% of the tipping loads and on tires do not exceed 65% of the tipping loads.

**Link-Belt Construction Equipment Company**      Lexington, Kentucky      [www.linkbelt.com](http://www.linkbelt.com)

®Link-Belt is a registered trademark. Copyright 2006. We are constantly improving our products and therefore reserve the right to change designs and specifications.