

160 X₂

specifications

Operating Weight: 37,700 lbs. (17,100 kg)

SAE Net Horsepower: 120 HP (89 kW)

Bucket Range: .50 - 1.14 yd³ (.38 - .87 m³)

Engine

Isuzu AI-4JJ1X Tier 3 turbocharged diesel engine with electronic fuel control, 4-cylinder, water-cooled, EGR with cooler, air-to-air intercooler, fuel cooler, auto idle-start, neutral safety start, glow plugs, auto warm-up, EPF engine protection, dual stage fuel filtration, remote oil filter, green plug oil drain.

SAE net horsepower 120 HP (89 kW) @ 2,200 rpm
 Displacement 3.0 L
 Maximum torque 288 lbf-ft (391 N-m) @ 1,800 rpm
 Starter 24V-4.0kW
 Alternator 50 amp
 Battery 72 amp hours

Cab and Controls

Pressurized cab with climate control a/c and heat with defroster, LCD monitor, illuminated soft-touch switches, low-effort controls pre-wired for auxiliary hydraulics, control pattern changer, sliding LEXAN® MARGARD® windows, safety glass front window with automatic locking system and vandal cover, intermittent windshield wiper with washer, emergency rear window exit, polycarbonate roof hatch with sunshade, shockless cab suspension with four fluid mountings, KAB® reclining suspension seat, sliding 4-position tilting control consoles, AM/FM radio, digital clock, dome light, seat belt, coat hook, cup holder, storage compartments, floor mat, footrests, ashtray, 24-volt cigarette lighter, 12-volt outlet, travel alarm, handrail, mirrors.

Four selectable working modes, anti-theft password protection system, on-board self-diagnostic system with memory, auto-idling system, one-touch decelerator, auto power boost, gate lock safety shutoff.

A/C output 18,100 BTU/hr
 Heater output 20,150 BTU/hr
 Sound level (inside cab) 68.4 dB(A)
 Sound level (exterior) 98.0 dB(A)

Hydraulic System

Open-center system, two variable displacement axial piston pumps and one gear pump for pilot controls, main control valve with one 4-spool valve and one 5-spool valve with auxiliary spool - stackable, oil cooler, auto power boost, boom and arm holding valves, o-ring face seals, 6 micron return filter, firewall.

Hydraulic Pumps

Maximum flow 2 x 37.5 gpm (2 x 142 l/min)
 Pilot pump maximum flow 5.8 gpm (22 l/min)

Relief Valve Settings

Boom/arm/bucket 4,970 psi (343 bar)
 in Power-Boost Mode 5,260 psi (363 bar)
 Swing circuit 4,050 psi (279 bar)
 Travel 4,970 psi (343 bar)

Hydraulic Cylinders

number of cylinders – bore x rod x stroke.
 Boom 2 – 4.5" x 3.1" x 46.4"
 (115 mm x 80 mm x 1 179 mm)
 Arm 1 – 4.9" x 3.5" x 50.4"
 (125 mm x 90 mm x 1 280 mm)
 Bucket 1 – 4.1" x 3.0" x 38.8"
 (105 mm x 75 mm x 985 mm)

Hydraulic Oil Filtration

Return filter 6 micron
 Pilot filter 8 micron
 Suction screen 105 micron



Swing

Planetary reduction powered by axial piston motor. Internal ring gear with grease cavity for swing pinion. Swing bearing is single-row shear type ball bearing. Mechanical disc swing brake. Auto power swing.

Swing speed 0 – 11.5 rpm
 Tail swing 8' 0" (2.45 m)
 Swing torque 33,264 lbf-ft. (45.1 kN·m)

Undercarriage

X Pattern carbody with 13' 1" (3.99 m) LC long undercarriage by 6' 6" (1.99 m) track gauge, sealed and strutted track chain, sealed rollers and idlers, two-speed independent hydrostatic travel with compact planetary final drive, disc type brakes, adjustable track tension, swivel guard.

Carrier rollers 2 per side
 Track rollers 7 per side
 Track link pitch 7.48" (190 mm)
 Shoes 44 per side
 Shoe width 23.6" (600 mm)
 Ground pressure 5.80 psi (.40 bar)

Lubricant and Coolant Capacity

Fuel tank 79.25 gal. (300 liters)
 Hydraulic tank 23.78 gal. (90 liters)
 Hydraulic system 43.59 gal. (165 liters)
 Final drive (per side) 1.19 gal. (4.5 liters)
 Swing drive 1.32 gal. (5 liters)
 Engine oil 4.49 gal. (17 liters)
 Cooling system 3.96 gal. (15 liters)

Travel System

Two-speed independent hydrostatic travel with compact axial piston motors. Hydraulic motor powered output shaft coupled to a planetary reduction unit and track sprocket. All hydraulic components mounted within the width of side frame.

Automatic downshift. Spring applied, hydraulically released disc parking brake built into each motor. Each travel motor equipped with counterbalance valve to prevent overspeeding down an incline.

Max. travel speed 1.7 - 3.4 mph (2.8 - 5.4 km/h)
 Drawbar pull 36,194 lbf (161 kN)
 Gradeability 70% (35°)

Attachment

Boom 16' 11" (5.15 m)
Available Arms **Digging Force***
 • 8' 7" (2.62 m) 17,760 lbf (79 kN)
 with Auto Power-Boost applied 18,880 lbf (84 kN)
 • 10' 0" (3.05 m) 16,190 lbf (72 kN)
 with Auto Power-Boost applied 17,310 lbf (77 kN)
 Bucket Digging Force 25,180 lbf (112 kN)
 with Auto Power-Boost applied 26,530 lbf (118 kN)

*Digging force ratings are based on ISO 6015, "Earthmoving Machinery – Hydraulic Excavators – Tool Forces."

Fuel Usage*

Heavy 3.94 gal / hr (14.9 liter / hr)
 Average 3.15 gal / hr (11.9 liter / hr)
 Light 1.97 gal / hr (7.5 liter / hr)

*Fuel economy varies widely depending on application. "Heavy" represents nearly continuous operation in tough digging applications in SP Mode. "Light" represents easy digging applications utilizing the machine about 50% of the time in SP Mode.

Operating Weight

Working weight with 23.6" (600 mm) shoes, 16' 11" (5.15 m) boom, 8' 7" (2.62 m) arm, 1,110 lb. (484 kg) bucket
 37,700 lbs (17,100 kg)

160 X2 Specifications

Working Ranges

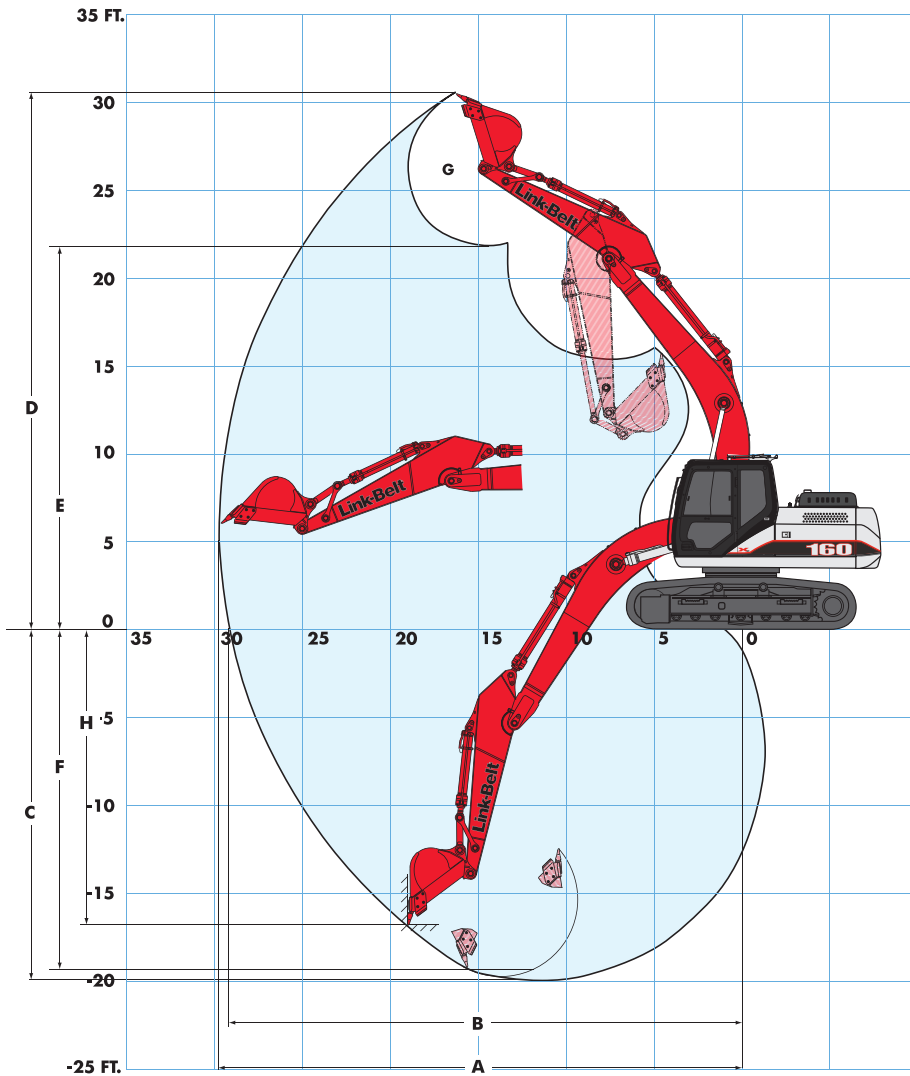

Machine equipped with 16' 11" (5.15 m) boom	8' 7" Arm (2.62 m)	10' 0" Arm (3.05 m)
A. Maximum reach	29' 8" (9.04 m)	30' 9" (9.38 m)
B. Maximum reach @ ground level	29' 1" (8.87 m)	30' 3" (9.22 m)
C. Maximum dig depth	19' 11" (6.06 m)	21' 4" (6.49 m)
D. Maximum dig height	30' 4" (9.24 m)	30' 6" (9.29 m)
E. Maximum dump height	21' 8" (6.61 m)	21' 11" (6.69 m)
F. Digging depth - 8' level bottom	19' 2" (5.85 m)	20' 8" (6.29 m)
G. Bucket rotation	178°	178°
H. Maximum vertical wall depth	16' 8" (5.08 m)	17' 2" (5.22 m)

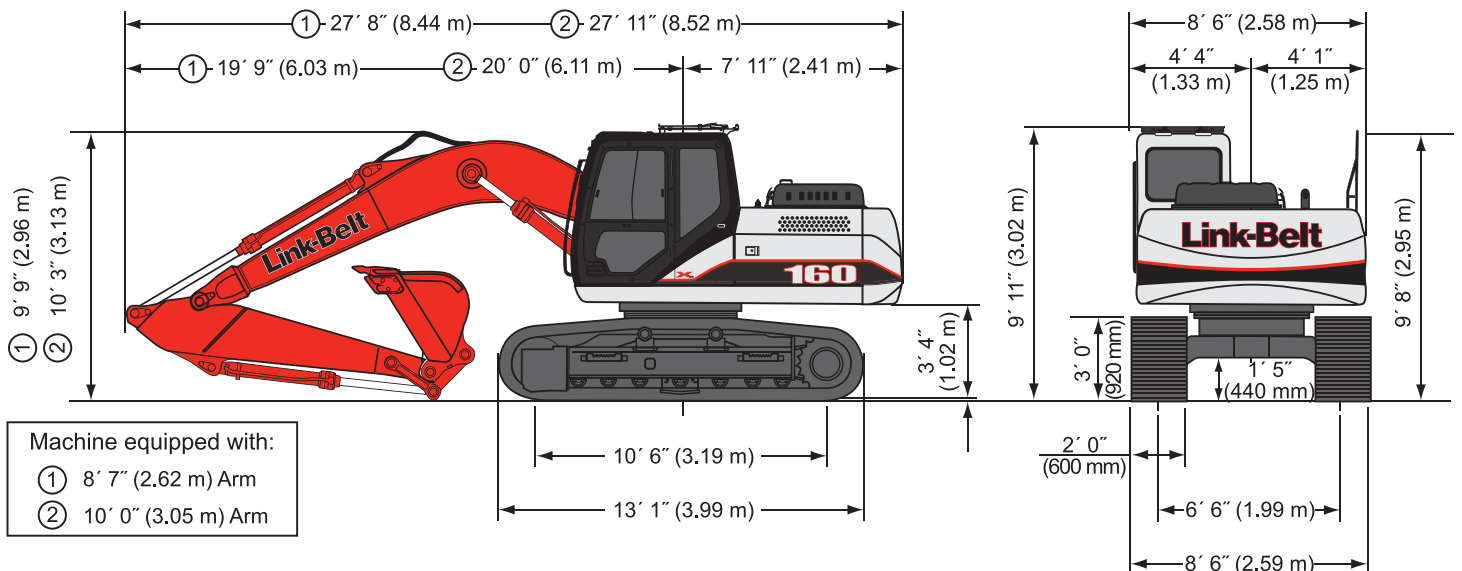

Lifting Capacities

8' 7" (2.62 m) Arm with 16' 11" (5.15 m) Boom and 1,067 lb. (484 kg) Bucket with Power-Boost Applied

		Radius of Load									
		10' 0" (3.05 m)		15' 0" (4.57 m)		20' 0" (6.10 m)		25' 0" (7.62 m)		Cap. at Max. Reach	
		End	Side	End	Side	End	Side	End	Side	End	Side
+25' 0" (7.62 m)	lbs kg									3,900* 1 769*	3,900* 1 769*
+20' 0" (6.10 m)	lbs kg					6,800* 3 084*	6,800 3 084			3,550* 1 610*	3,550* 1 610*
+15' 0" (4.57 m)	lbs kg					9,200* 4 173	6,750 3 062			3,450* 1 565*	3,450* 1 565*
+10' 0" (3.05 m)	lbs kg	18,100* 8 210*	18,100* 8 210*	12,650* 5 738*	10,200 4 627	10,300* 4 672*	6,400 2 903	7,100 3 221	4,350 1 973	3,500* 1 588*	3,400 1 542
+5' 0" (1.52 m)	lbs kg	22,550* 10 228*	17,150 7 779	15,750 7 144	9,350 4 241	9,900 4 491	6,000 2 722	6,900 3 130	4,150 1 882	3,700* 1 678*	3,300 1 497
Ground Line	lbs kg	17,800* 8 074*	15,900 7 212	15,050 6 827	8,700 3 946	9,550 4 332	5,700 2 586	6,750 3 062	4,000 1 814	4,150* 1 882*	3,400 1 542
-5' 0" (1.52 m)	lbs kg	22,250* 10 092*	16,050 7 280	14,750 6 691	8,450 3 833	9,350 4 241	5,500 2 495	6,150* 2 789*	3,950 1 792	4,850* 2 200*	3,850 1 746
-10' 0" (3.05 m)	lbs kg	27,850* 12 632*	16,400 7 439	14,800 6 713	8,500 3 856	9,350 4 241	5,500 2 517			6,350* 2 880*	5,050 2 291
-15' 0" (4.57 m)	lbs kg	22,450* 10 183*	16,950 7 689	15,050* 6 826*	8,850 4 014						

10' 0" (3.05 m) Arm with 16' 11" (5.15 m) Boom and 970 lb. (440 kg) Bucket with Power-Boost Applied

		Radius of Load									
		10' 0" (3.05 m)		15' 0" (4.57 m)		20' 0" (6.10 m)		25' 0" (7.62 m)		Cap. at Max. Reach	
		End	Side	End	Side	End	Side	End	Side	End	Side
+25' 0" (7.62 m)	lbs kg									3,650* 1 656*	3,650* 1 656*
+20' 0" (6.10 m)	lbs kg					7,000* 3 175*	7,000 3 175			3,350* 1 520*	3,350* 1 520*
+15' 0" (4.57 m)	lbs kg					8,400* 3 810*	6,900 3 130	5,200* 2 358*	4,550 2 064	3,300* 1 497*	3,300* 1 497*
+10' 0" (3.05 m)	lbs kg			11,450* 5 193*	10,450 4 740	9,850* 4 467*	6,550 2 971	7,200 3 266	4,400 1 996	3,400* 1 542*	3,200 1 452
+5' 0" (1.52 m)	lbs kg	23,950* 10 863*	17,650 8 006	15,100* 6 849*	9,500 4 309	10,000 4 536	6,100 2 767	6,950 3 153	4,200 1 905	3,600* 1 633*	3,100 1 406
Ground Line	lbs kg	20,250* 9 185*	16,150 7 326	15,150 6 872	8,800 3 992	9,600 4 355	5,750 2 608	6,750 3 062	4,000 1 814	4,050* 1 837*	3,150 1 429
-5' 0" (1.52 m)	lbs kg	23,150* 10 500*	15,950 7 235	14,700 6 668	8,450 3 833	9,350 4 241	5,500 2 495	6,650 3 016	3,900 1 769	4,800* 2 177*	3,550 1 610
-10' 0" (3.05 m)	lbs kg	28,750* 13 041*	16,150 7 326	14,700 6 668	8,400 3 810	9,300 4 218	5,450 2 472			6,200* 2 812*	4,450 2 019
-15' 0" (4.57 m)	lbs kg	24,500* 11 113*	16,600 7 530	15,000 6 804	8,650 3 924						

Notes: Excavator lifting capacities

- Lifting capacities shown should not be exceeded. Weight of all lifting accessories must be deducted from the above lifting capacities.
- Lifting capacities are based on machine standing on firm, uniform supporting surface. User must make allowances for job conditions such as soft or uneven ground.
- Lifting capacities shown do not exceed 75% of minimum tipping loads or 87% of hydraulic capacities. **Capacities marked with an asterisk (*) are limited by hydraulic capacities.**
- Least stable position is over the side.
- Operator should be fully acquainted with the Operator's Manual & Operating Safety Booklet, furnished by LBX before operating the machine.
- Capacities apply only to the machine as originally manufactured and normally equipped by LBX Company, LLC.
- Lift capacity ratings are based on SAE J1097, "Earthmoving Machinery – Hydraulic Excavators – Lift Capacity".

160 X2 Specifications

Bucket Sizes

Bucket Type	SAE Heaped Capacity (yd ³)		Width Outside Lip (in) (mm)		Bucket Weight (lbs) (kg)		Number of Teeth	Arm Length 8'-7" 10'-0" (2.62 m) (3.05 m)	
STDP	0.58	0.44	24	610	913	415	4	H	H
	0.76	0.58	30	762	1016	462	4	H	H
	0.95	0.73	36	914	1139	518	5	M	L
	1.14	0.87	42	1067	1245	566	6	L	L
HDP	0.57	0.44	24	610	1203	547	4	H	H
	0.76	0.58	30	762	1336	607	4	H	M
	0.95	0.73	36	914	1468	667	5	M	L
	1.14	0.87	42	1067	1598	726	5	L	L
XDP	0.50	0.38	24	610	1085	493	4	H	H
	0.65	0.50	30	762	1202	546	4	H	H
	0.81	0.62	36	914	1347	612	5	M	M
	0.97	0.74	42	1067	1464	665	5	L	L
	1.13	0.86	48	1219	1581	718	5	L	N/A
POWER	0.50	0.38	24	610	1554	706	4	H	H
	0.65	0.50	30	762	1654	752	4	H	M
	0.81	0.62	36	914	1780	809	5	M	M
DITCH	0.95	0.73	60	1524	1050	477	-	M	M
	1.06	0.81	66	1676	1124	511	-	L	L

STDP - Standard duty plate
HDP - Heavy duty plate
XDP - Extreme duty plate
POWER - HDP for use with ESCO multi-pin grabber only

Approval Code For Arm/Bucket Combinations

H..... Heavy material (up to 3,370 lbs./yd³)
M..... Medium material (up to 2,700 lbs./yd³)
L..... Light material (up to 2,020 lbs./yd³)
N/A..... Not applicable

Standard Equipment

- KAB 815 sliding/reclining suspension seat with adjustable 4-inch armrests, lumbar support and retractable seat belt
- Safety glass front window with auto lock, windshield wiper and washer with intermittent speeds, Lexan® side and rear tinted windows
- 4-position tilting consoles with memory position and hydraulic lock-out
- Auto climate control a/c and heat
- AM/FM stereo with mute button, horn, interior light, digital clock, hour meter, floor mat, cup holder, sun shade, storage, LH and RH rear view mirrors
- Travel alarm with cancel switch
- Vandal guarding with bolt-on FOG capability
- EPA Tier III Isuzu diesel engine
- Common rail fuel injection
- Turbocharger with intercooler
- Neutral safety start
- Idle start
- Glow plug pre-heat
- Auto engine warm-up
- Auto idling system
- One-touch idle
- Dual remote fuel filters with water separation
- Double element air filter with in-cab restriction indicator
- External fuel gauge
- Remote, full-flow engine oil filter
- Green plug engine oil drain
- EPF Engine Protection
- Emergency engine stop
- Open-center hydraulic system
- Four selectable work modes including attachment mode
- Auto power boost
- Auto swing priority
- Pre-set auxiliary pump settings - 10
- Auxiliary valve
- Stackable main control valve
- Auxiliary pipe brackets
- Control levers pre-wired for auxiliary
- Control pattern changer
- Long undercarriage
- Sealed and lubricated track chain
- Two-speed with auto shift and straight travel
- Planetary drive
- Spring-applied, hydraulic release brake
- Hydraulic track adjust
- Swivel guard belly pan
- Track guides
- Vandal locks with common key
- 7,538 lb (3,419 kg) counterweight with lifting eyes
- Hand rail
- Tool box
- 16-ft 11-in boom
- EMS (Extended Maintenance System) 1,000 hour service interval throughout entire attachment except bucket
- Attachment cushion valve
- Arm and boom speed assistance
- Arm and boom regeneration
- Arm and boom holding valves
- Cylinder cushion
- Centralized lube bank
- Bucket anti-clatter device
- Illuminated LCD service monitor
- On-board diagnostic system
- Anti-theft device
- 12-volt accessory outlet
- 70-watt work lights on boom and upper

Options

- Arms
 - 8-ft 7-in (2.62 m)
 - 10-ft 0-in (3.05 m)
- Tracks
 - 23.6-in (600 mm) 3-bar grouser
 - 27.5-in (700 mm) 3-bar grouser
- Hydraulics
 - Single-acting with switch activation
 - Multi-function with switch activation and in-cab flow direction control
 - Thumb hydraulics with switch activation
 - Secondary auxiliary with switch activation for rotate or tilt
 - Combination auxiliary with multi-function and secondary hydraulics
- Couplers
 - ESCO multi-pin grabber
 - Dromone automatic quick-coupler
- Thumbs
 - ESCO Universal rigid
 - ESCO Hydraulic non-link
 - ESCO Hydraulic non-link for coupler
 - ESCO Hydraulic link
 - ESCO Hydraulic link for coupler
- Cab lights - exterior
- Air-suspension seat
- Free Swing
- FOG guard
- Front guard - mesh or bars
- HD bucket linkage



LBX Company is the proud maker of quality Link-Belt excavators and is located in Lexington, KY.

Litho in USA 5/10 #LBX2173 (supersedes #LBX2132)

© LBX and © Link-Belt are registered trademarks. Copyright 2010. All rights reserved. We are constantly improving our products and therefore reserve the right to change designs and specifications.



www.lbxco.com