

240X₂

specifications

Operating Weight: 54,895 lbs. (24 900 kg)

SAE Net Horsepower: 177 HP (132 kW)

Bucket Range: .76 - 2.43 yd³ (.58 - 1.86 m³)

Engine

Isuzu AH-4HK1X Tier 3 turbocharged diesel engine with electronic fuel control, 4-cylinder, water-cooled, EGR with cooler, air-to-air intercooler, fuel cooler, auto idle start, neutral safety start, glow plugs, auto warm-up, EPF engine protection, dual stage fuel filtration, remote oil filter, green plug oil drain.

SAE net horsepower 177 HP (132 kW) @ 2,000 rpm
Displacement 5.2 L
Maximum torque 469 lbf-ft (636 N-m) @ 1,500 rpm
Starter 24V-5.0kW
Alternator 50 amp
Battery 92 amp hours

Cab and Controls

Pressurized cab with climate control a/c and heat with defroster, LCD monitor, illuminated soft-touch switches, low-effort controls pre-wired for auxiliary hydraulics, control pattern changer, single pedal travel, sliding LEXAN® MARGARD® windows, safety glass front window with automatic locking system and vandal cover, intermittent windshield wiper with washer, emergency rear window exit, polycarbonate roof hatch with sunshade, shockless cab suspension with four fluid mountings, KAB® reclining suspension seat, sliding 4-position tilting control consoles, AM/FM radio, digital clock, dome light, seat belt, coat hook, cup holder, storage compartments, floor mat, footrests, ashtray, 24-volt cigarette lighter, 12-volt outlet, travel alarm, handrail, mirrors.

Four selectable working modes, anti-theft password protection system, on-board self-diagnostic system with memory, auto-idling system, one-touch decelerator, auto power boost, gate lock safety shutoff.

A/C output 18,100 BTU/hr
Heater output 20,150 BTU/hr
Sound level (inside cab) 70.5 dB(A)
Sound level (exterior) 99.7 dB(A)

Hydraulic System

Open-center system, two variable displacement axial piston pumps and one gear pump for pilot controls, main control valve with one 4-spool valve and one 5-spool valve with auxiliary spool - stackable, oil cooler, auto power boost, boom and arm holding valves, o-ring face seals, 6 micron return filter, firewall.

Hydraulic Pumps

Maximum flow 2 x 61.8 gpm (2 x 234 l/min)
Pilot pump maximum flow 5.3 gpm (20 l/min)

Relief Valve Settings

Boom/arm/bucket 4,970 psi (343 bar)
in Power-Boost Mode 5,340 psi (368 bar)
Swing circuit 4,190 psi (289 bar)
Travel 4,970 psi (343 bar)

Hydraulic Cylinders

number of cylinders – bore x rod x stroke
Boom 2 – 5.1" x 3.5" x 52.6"
(130 mm x 90 mm x 1 335 mm)
Arm 1 – 5.7" x 4.1" x 65.4"
(145 mm x 105 mm x 1 660 mm)
Bucket 1 – 5.1" x 3.5" x 42.1"
(130 mm x 90 mm x 1 070 mm)

Hydraulic Oil Filtration

Return filter 6 micron
Pilot filter 8 micron
Suction screen 155 micron



Swing

Planetary reduction powered by axial piston motor. Internal ring gear with grease cavity for swing pinion. Swing bearing is single-row shear type ball bearing. Mechanical disc swing brake. Auto power swing.

Swing speed 0 – 10.7 rpm
Tail swing 9' 8" (2.95 m)
Swing torque 55,243 lbf-ft. (74.9 kN•m)

Undercarriage

X Pattern carbody with 15' 3" (4.65 m) LC long undercarriage by 8' 6" (2.6 m) track gauge, sealed and strutted track chain with track guide, sealed rollers and idlers, two-speed independent hydrostatic travel with compact planetary final drive, disc type brakes, adjustable track tension, swivel guard.

Carrier rollers 2 per side
Track rollers 9 per side
Track link pitch 7.48" (190 mm)
Shoes 51 per side
Shoe width 31.5" (800 mm)
Ground pressure 5.37 psi (.37 bar)

Lubricant and Coolant Capacity

Fuel tank 108.31 gal. (410 liters)
Hydraulic tank 38.8 gal. (147 liters)
Hydraulic system 66.04 gal. (250 liters)
Final drive (per side) 1.3 gal. (5.0 liters)
Swing drive 2.56 gal. (9.7 liters)
Engine oil 6.1 gal. (23.1 liters)
Cooling system 6.7 gal. (25.2 liters)

Travel System

Two-speed independent hydrostatic travel with compact axial piston motors. Hydraulic motor powered output shaft coupled to a planetary reduction unit and track sprocket. All hydraulic components mounted within the width of side frame. Automatic downshift. Single pedal travel. Spring applied, hydraulically released disc parking brake built into each motor. Each travel motor equipped with counterbalance valve to prevent overspeeding down an incline.

Max. travel speed 2.2 - 3.4 mph (3.5 - 5.5 km/hr)
Drawbar pull 45,254 lbf (201 kN)
Gradeability 70% (35°)

Attachment

Boom 19' 2" (5.85 m)
Available Arms **Digging Force***
• 9' 10" (3.00 m) 26,980 lbf (120 kN)
with Auto Power-Boost applied 29,000 lbf (129 kN)
• 8' 2" (2.50 m) 31,700 lbf (141 kN)
with Auto Power-Boost applied 33,950 lbf (151 kN)
• 11' 6" (3.50 m) 24,050 lbf (107 kN)
with Auto Power-Boost applied 25,850 lbf (115 kN)
Bucket Digging Force 36,420 lbf (162 kN)
with Auto Power-Boost applied 39,120 lbf (174 kN)

*Digging force ratings are based on ISO 6015, "Earthmoving Machinery – Hydraulic Excavators – Tool Forces."

Fuel Usage*

Heavy 6.80 gal / hr (25.7 liter / hr)
Average 5.44 gal / hr (20.6 liter / hr)
Light 3.40 gal / hr (12.9 liter / hr)

*Fuel economy varies widely depending on application. "Heavy" represents nearly continuous operation in tough digging applications in SP Mode. "Light" represents easy digging applications utilizing the machine about 50% of the time in SP Mode.

Operating Weight

Working weight with 31.5" (800 mm) shoes, 19' 2" (5.85 m) boom, 9' 10" (3.00 m) arm 1,790 lb. (810 kg) bucket
..... 54,895 lbs (24,900 kg)

240 X2 Specifications

Working Ranges

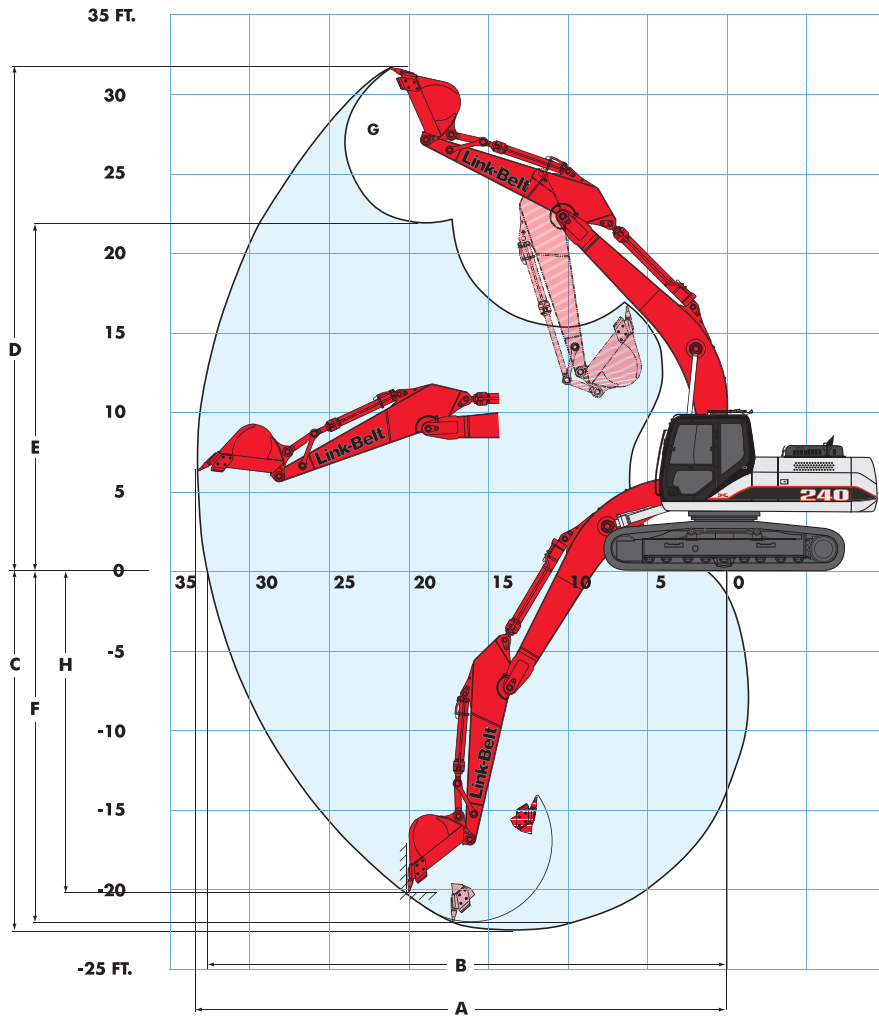

Machine equipped with 19' 2" (5.85 m) boom	9' 10" Arm (3.00 m)	8' 2" Arm (2.50 m)	11' 6" Arm (3.50 m)
A. Maximum reach	33' 9" (10.28 m)	32' 3" (9.82 m)	35' 5" (10.79 m)
B. Maximum reach @ ground level	33' 2" (10.10 m)	31' 7" (9.63 m)	34' 10" (10.62 m)
C. Maximum dig depth	22' 8" (6.9 m)	21' 0" (6.40 m)	24' 4" (7.42 m)
D. Maximum dig height	32' 0" (9.76 m)	31' 4" (9.56 m)	33' 0" (10.07 m)
E. Maximum dump height	22' 2" (6.76 m)	21' 6" (6.55 m)	23' 2" (7.06 m)
F. Digging depth - 8' (2.44 m) level bottom	22' 1" (6.74 m)	20' 4" (6.21 m)	23' 10" (7.27 m)
G. Bucket rotation	175°	175°	175°
H. Maximum vertical wall depth	20' 2" (6.14 m)	18' 8" (5.70 m)	21' 11" (6.68 m)

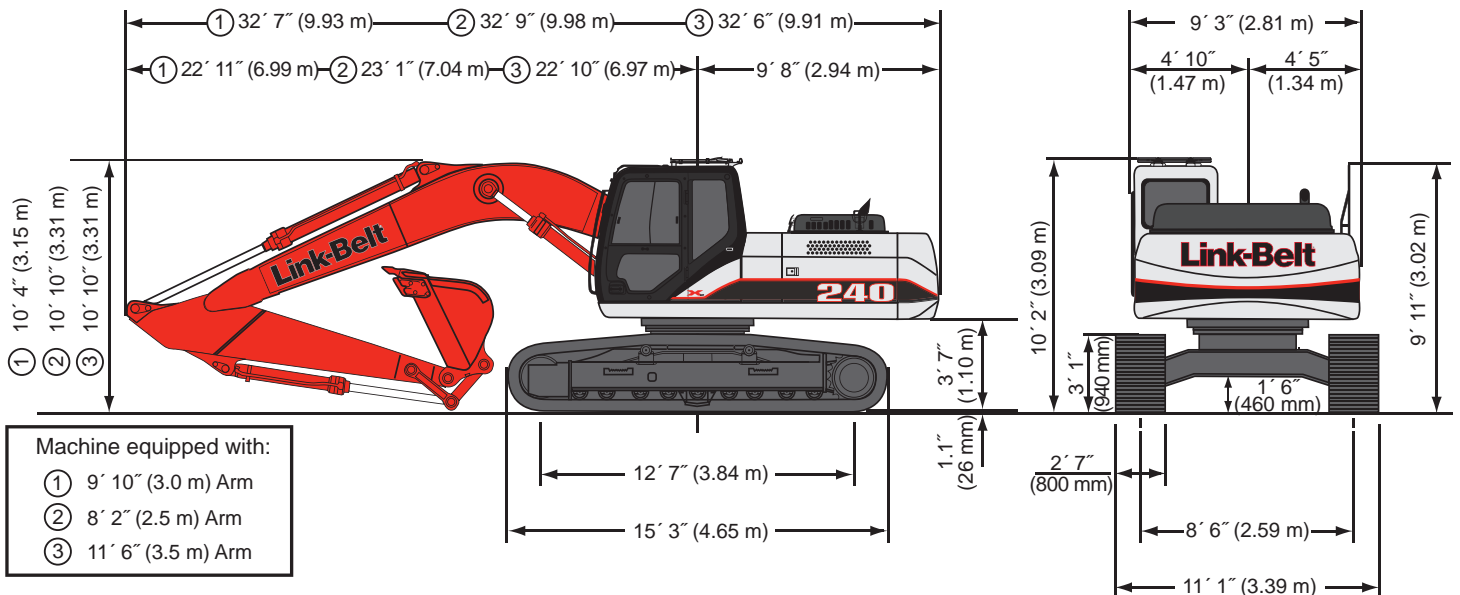

240 X2 Specifications

Bucket Sizes

Bucket Type	SAE Heaped Capacity		Width Outside Lip		Bucket Weight		Number of Teeth	Arm Length		
	(yd³)	(m³)	(in)	(mm)	(lbs)	(kg)		8'-2" 2.50 m	9'-10" 3.00 m	11'-6" 3.50 m
STDP	0.80	0.61	24	610	1285	583	3	H	H	H
	1.06	0.81	30	762	1458	661	4	H	H	H
	1.33	1.02	36	914	1630	739	5	H	H	M
	1.61	1.23	42	1067	1774	805	5	H	M	L
	1.89	1.45	48	1219	1918	870	5	M	L	L
	2.16	1.65	54	1327	2091	948	6	L	L	N/A
HDP	0.80	0.61	24	610	1498	679	3	H	H	H
	1.06	0.81	30	762	1705	773	4	H	H	H
	1.33	1.02	36	914	1873	850	4	H	H	M
	1.61	1.23	42	1067	2080	943	5	M	M	L
	1.89	1.45	48	1219	2247	1019	5	L	L	L
	2.16	1.65	54	1372	2454	1113	6	L	L	N/A
XDP	0.79	0.60	24	610	2230	1012	3	H	H	H
	1.05	0.80	30	762	2528	1147	4	H	H	H
	1.32	1.01	36	914	2749	1247	4	H	M	M
	1.59	1.22	42	1067	3047	1382	5	M	L	L
	1.87	1.43	48	1219	3267	1482	5	L	L	N/A
	2.15	1.64	54	1372	3565	1617	6	L	N/A	N/A
POWER	0.76	0.58	24	610	3025	1372	3	H	H	H
	0.98	0.75	30	762	3183	1444	4	H	H	H
	1.21	0.93	36	914	3392	1539	4	H	M	L
	1.44	1.10	42	1067	3552	1611	5	M	L	L
	1.68	1.28	48	1219	3709	1682	5	L	L	N/A
	1.91	1.46	54	1372	3920	1778	6	L	N/A	N/A
DITCH	1.30	0.99	60	1524	1767	802	0	H	H	M
	1.45	1.11	66	1676	1928	875	0	H	H	M
	1.59	1.22	72	1829	2034	923	0	M	M	L

STDP - Standard duty plate
HDP - Heavy duty plate
XDP - Extreme duty plate
POWER - HDP for use with ESCO multi-pin grabber only

Approval Code For Arm/Bucket Combinations

H..... Heavy material
(up to 3,370 lbs./yd³)
M..... Medium material
(up to 2,700 lbs./yd³)
L..... Light material
(up to 2,020 lbs./yd³)
N/A..... Not applicable

Standard Equipment

- KAB 515 sliding/reclining suspension seat with adjustable 4-inch armrests, lumbar support and retractable seat belt
- Safety glass front window with auto lock, windshield wiper and washer with intermittent speeds, Lexan® side and rear tinted windows
- 4-position tilting consoles with memory position and hydraulic lock-out
- Auto climate control a/c and heat
- AM/FM stereo with mute button, horn, interior light, digital clock, hour meter, floor mat, cup holder, sun shade, storage, LH and RH rear view mirrors
- Single pedal travel
- Travel alarm with cancel switch
- Vandal guarding with bolt-on FOG capability
- EPA Tier III Isuzu diesel engine
- Common rail fuel injection
- Turbocharger with intercooler
- Neutral safety start
- Idle start
- Glow plug pre-heat
- Auto engine warm-up
- Auto idling system
- One-touch idle
- Dual remote fuel filters with water separation
- Double element air filter with in-cab restriction indicator
- External fuel gauge
- Remote, full-flow engine oil filter
- Green plug engine oil drain
- EPF Engine Protection
- Emergency engine stop
- Open-center hydraulic system
- Four selectable work modes including attachment mode
- Auto power boost
- Auto swing priority
- Pre-set auxiliary pump settings - 10
- Auxiliary valve
- Stackable main control valve
- Auxiliary pipe brackets
- Control levers pre-wired for auxiliary
- Control pattern changer
- Long undercarriage
- Sealed and lubricated track chain
- Two-speed with auto shift and straight travel
- Planetary drive
- Spring-applied, hydraulic release brake
- Hydraulic track adjust
- Swivel guard belly pan
- Track guide
- Vandal locks with common key
- 11,616 lb (5,269 kg) counterweight with lifting eyes
- Hand rail
- Tool box
- 19-ft 2-in (5.85 m) boom
- EMS (Extended Maintenance System) 1,000 hour service interval throughout entire attachment except bucket
- Attachment cushion valve
- Arm and boom speed assistance
- Arm and boom regeneration
- Arm and boom holding valves
- Cylinder cushion
- Centralized lube bank
- Bucket anti-clatter device
- Illuminated LCD service monitor
- On-board diagnostic system
- Anti-theft device
- 12-volt accessory outlet
- 70-watt work lights on boom and upper

Options

- Arms
 - 8-ft 10-in (3.00 m)
 - 8-ft 2-in (2.50 m)
 - 11-ft 6-in (3.50 m)
- Tracks
 - 31.5-in (800 mm) 3-bar grouser
 - 27.5-in (700 mm) 3-bar grouser
 - 23.6-in (600 mm) 3-bar grouser
- Hydraulics
 - Single-acting with switch or pedal activation
 - Multi-function with switch activation and in-cab flow direction control
 - Thumb hydraulics with switch activation
 - 2nd and 3rd auxiliary with pedal activation
- Couplers
 - ESCO multi-pin grabber
 - Dromone Quick-Coupler
- Thumbs
 - Universal rigid
 - Hydraulic non-link
 - Hydraulic non-link for coupler
 - Hydraulic link
 - Hydraulic link for coupler
- Cab lights - exterior
- Air-suspension seat
- Free Swing
- Cyclone pre-clean air filter
- FOG guard
- Front guard - mesh or bars
- Attachment reinforcement plating
- HD bucket linkage
- Track guides - triple

Link-Belt

EXCAVATORS • FORESTRY
DEMOLITION • MATERIAL HANDLING

LBX Company is the proud maker of quality Link-Belt excavators and is located in Lexington, KY.

LBX
"Different by Design"

www.lbxco.com

Litho in USA 8/11 #LBX2181 (supersedes #LBX2140)

© LBX and © Link-Belt are registered trademarks. Copyright 2011. All rights reserved. We are constantly improving our products and therefore reserve the right to change designs and specifications.