

# 290 X<sub>2</sub>

## specifications

Operating Weight: 65,700 lbs. (29 800 kg)

SAE Net Horsepower: 207 HP (154 kW)

Bucket Range: .76 - 2.43 yd<sup>3</sup> (.58 - 1.86 m<sup>3</sup>)

### Engine

Isuzu AH-6HK1XYSS Tier 3 turbocharged diesel engine with electronic fuel control, 6-cylinder, water-cooled, EGR with cooler, air-to-air intercooler, fuel cooler, auto idle start, neutral safety start, glow plugs, auto warm-up, EPF engine protection, dual stage fuel filtration, remote oil filter, green plug oil drain.

SAE net horsepower ..... 207 HP (154 kW) @ 1,800 rpm  
 Displacement ..... 7.8 L  
 Maximum torque ..... 627 lbf-ft (850 N-m) @ 1,500 rpm  
 Starter ..... 24V-5.0kW  
 Alternator ..... 50 amp  
 Battery ..... 128 amp hours

### Cab and Controls

Pressurized cab with climate control a/c and heat with defroster, LCD monitor, illuminated soft-touch switches, low-effort controls pre-wired for auxiliary hydraulics, control pattern changer, single pedal travel, sliding LEXAN® MARGARD® windows, safety glass front window with automatic locking system and vandal cover, intermittent windshield wiper with washer, emergency rear window exit, polycarbonate roof hatch with sunshade, shockless cab suspension with four fluid mountings, KAB® reclining suspension seat, sliding 4-position tilting control consoles, AM/FM radio, digital clock, dome light, seat belt, coat hook, cup holder, storage compartments, floor mat, footrests, ashtray, 24-volt cigarette lighter, 12-volt outlet, travel alarm, handrail, mirrors.

Four selectable working modes, anti-theft password protection system, on-board self-diagnostic system with memory, auto-idling system, one-touch decelerator, auto power boost, gate lock safety shutoff.

A/C output ..... 18,100 BTU/hr  
 Heater output ..... 20,150 BTU/hr  
 Sound level (inside cab) ..... 70.5 dB(A)  
 Sound level (exterior) ..... 99.7 dB(A)

### Hydraulic System

Open-center system, two variable displacement axial piston pumps and one gear pump for pilot controls, main control valve with one 4-spool valve and one 5-spool valve with auxiliary spool - stackable, oil cooler, auto power boost, boom and arm holding valves, o-ring face seals, 6 micron return filter, firewall.

#### Hydraulic Pumps

Maximum flow ..... 2 x 64.2 gpm (2 x 243 l/min)  
 Pilot pump maximum flow ..... 7.1 gpm (27 l/min)

#### Relief Valve Settings

Boom/arm/bucket ..... 4,970 psi (343 bar)  
 in Power-Boost Mode ..... 5,400 psi (373 bar)  
 Swing circuit ..... 4,260 psi (294 bar)  
 Travel ..... 4,970 psi (343 bar)

#### Hydraulic Cylinders

number of cylinders – bore x rod x stroke  
 Boom ..... 2 – 5.5" x 3.7" x 53.9"  
 (140 mm x 95 mm x 1 369 mm)  
 Arm ..... 1 – 5.9" x 4.1" x 61.8"  
 (150 mm x 105 mm x 1 569 mm)  
 Bucket ..... 1 – 5.3" x 3.5" x 42.4"  
 (135 mm x 90 mm x 1 078 mm)

#### Hydraulic Oil Filtration

Return filter ..... 6 micron  
 Pilot filter ..... 8 micron  
 Suction screen ..... 150 mesh



### Swing

Planetary reduction powered by axial piston motor. Internal ring gear with grease cavity for swing pinion. Swing bearing is single-row shear type ball bearing. Mechanical disc swing brake. Auto power swing.

Swing speed ..... 0 – 10.2 rpm  
 Tail swing ..... 10' 4" (3.16 m)  
 Swing torque ..... 68,224 lbf-ft. (92.5 kN·m)

### Undercarriage

X Pattern carbody with 15' 11" (4.85 m) LC long undercarriage by 8' 6" (2.6 m) track gauge, sealed and strutted track chain with track guide, sealed rollers and idlers, two-speed independent hydrostatic travel with compact planetary final drive, disc type brakes, adjustable track tension, swivel guard.

Carrier rollers ..... 2 per side  
 Track rollers ..... 9 per side  
 Track link pitch ..... 7.99" (203 mm)  
 Shoes ..... 50 per side  
 Shoe width ..... 31.5" (800 mm)  
 Ground pressure ..... 6.24 psi (.43 bar)

### Lubricant and Coolant Capacity

Fuel tank ..... 118.88 gal. (450 liters)  
 Hydraulic tank ..... 38.8 gal. (147 liters)  
 Hydraulic system ..... 79.25 gal. (300 liters)  
 Final drive (per side) ..... 2.4 gal. (9.1 liters)  
 Swing drive ..... 1.59 gal. (6 liters)  
 Engine oil ..... 10.04 gal. (38 liters)  
 Cooling system ..... 7.66 gal. (29 liters)

### Travel System

Two-speed independent hydrostatic travel with compact axial piston motors. Hydraulic motor powered output shaft coupled to a planetary reduction unit and track sprocket. All hydraulic components mounted within the width of side frame. Automatic downshift. Single pedal travel. Spring applied, hydraulically released disc parking brake built into each motor. Each travel motor equipped with counterbalance valve to prevent overspeeding down an incline.

Max. travel speed ..... 2.0 - 3.5 mph (3.2 - 5.6 km/h)  
 Drawbar pull ..... 52,380 lbf (233 kN)  
 Gradeability ..... 70% (35°)

### Attachment

Boom ..... 20' 2" (6.15 m)

#### Available Arms

**Digging Force\***  
 • 10' 5" (3.18 m) ..... 27,340 lbf (122 kN)  
 with Auto Power-Boost applied ..... 29,760 lbf (132 kN)  
 • 8' 8" (2.65 m) ..... 31,520 lbf (140 kN)  
 with Auto Power-Boost applied ..... 34,400 lbf (153 kN)  
 • 12' 0" (3.66 m) ..... 24,680 lbf (110 kN)  
 with Auto Power-Boost applied ..... 26,680 lbf (119 kN)

Bucket Digging Force ..... 39,250 lbf (175 kN)  
 with Auto Power-Boost applied ..... 42,760 lbf (190 kN)

\*Digging force ratings are based on ISO 6015, "Earthmoving Machinery – Hydraulic Excavators – Tool Forces."

### Fuel Usage\*

Heavy ..... 7.50 gal / hr (28.4 liter / hr)  
 Average ..... 6.00 gal / hr (22.7 liter / hr)  
 Light ..... 3.75 gal / hr (14.2 liter / hr)

\*Fuel economy varies widely depending on application. "Heavy" represents nearly continuous operation in tough digging applications in SP Mode. "Light" represents easy digging applications utilizing the machine about 50% of the time in SP Mode.

### Operating Weight

Working weight with 31.5" (800 mm) shoes, 20' 2" (6.15 m) boom, 10' 5" (3.18 m) arm, 1,940 lb. (880 kg) bucket ..... 65,700 lbs (29,800 kg)

# 290 X2 Specifications

## Working Ranges

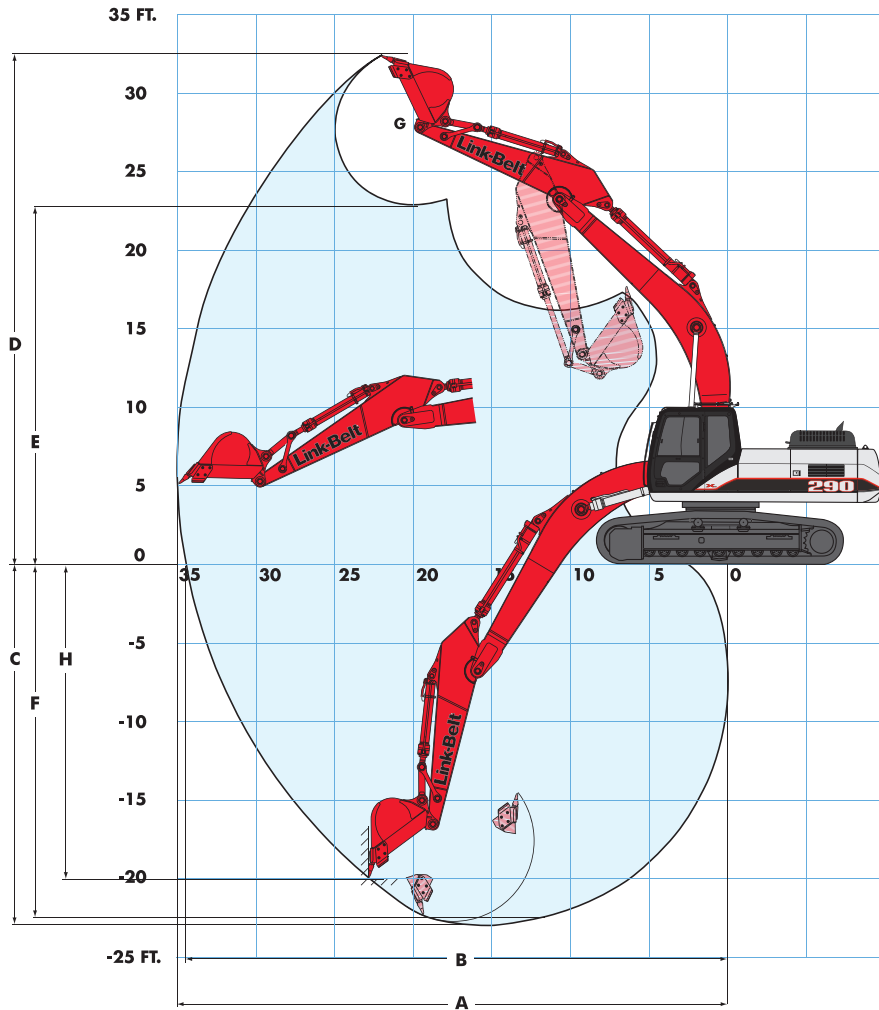

Machine equipped with 20' 2" (6.15 m) boom	10' 5" Arm (3.18 m)	8' 8" Arm (2.65 m)	12' 0" Arm (3.66 m)
A. Maximum reach	35' 0" (10.67 m)	33' 6" (10.22 m)	36' 7" (11.16 m)
B. Maximum reach @ ground level	34' 5" (10.50 m)	32' 11" (10.04 m)	36' 1" (10.99 m)
C. Maximum dig depth	23' 4" (7.10 m)	21' 7" (6.57 m)	24' 10" (7.58 m)
D. Maximum dig height	33' 0" (10.06 m)	32' 7" (9.93 m)	34' 1" (10.39 m)
E. Maximum dump height	23' 3" (7.09 m)	22' 9" (6.94 m)	24' 3" (7.39 m)
F. Digging depth - 8' (2.44 m) level bottom	22' 9" (6.94 m)	21' 0" (6.39 m)	24' 5" (7.44 m)
G. Bucket rotation	176°	176°	176°
H. Maximum vertical wall depth	20' 1" (6.12 m)	18' 11" (5.76 m)	22' 1" (6.72 m)

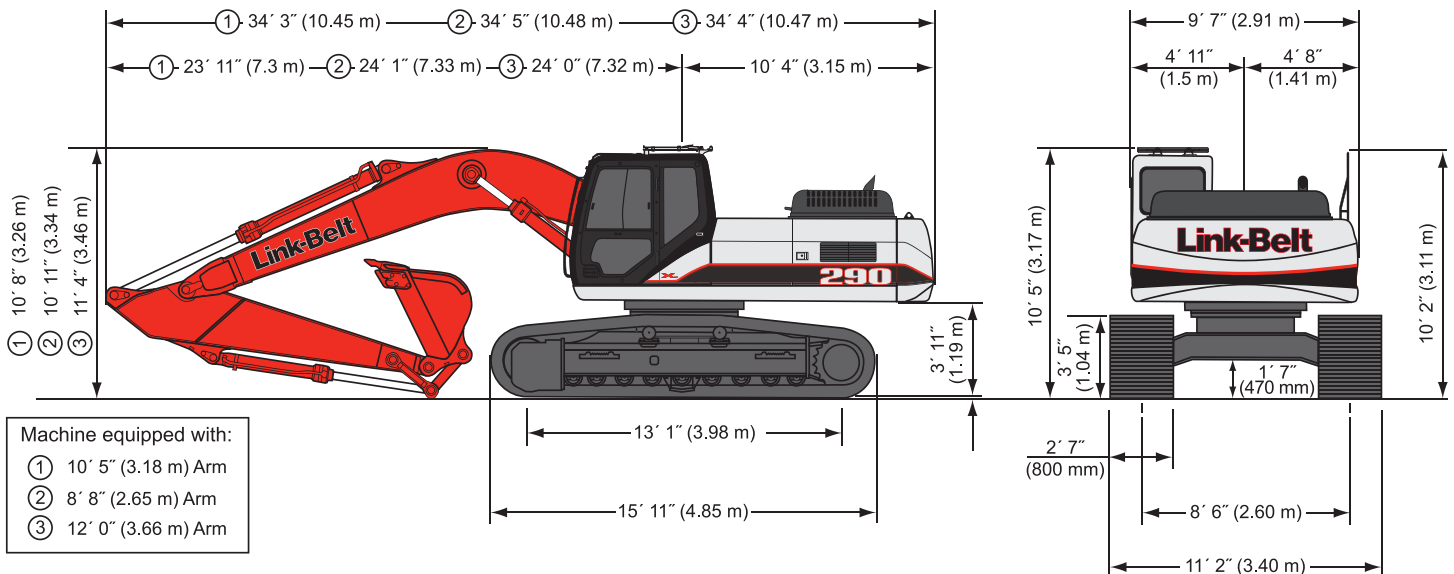

# 290 X2 Specifications

## Lifting Capacities

10' 5" (3.18 m) Arm with 20' 2" (6.15 m) Boom and 1,778 lb. (806 kg) Bucket with Power-Boost Applied

		Radius of Load										Cap. at Max. Reach		
		10' 0" (3.05 m)		15' 0" (4.57 m)		20' 0" (6.10 m)		25' 0" (7.62 m)		30' 0" (9.14 m)		End	Side	
		End	Side	End	Side	End	Side	End	Side	End	Side	End	Side	
+30' 0"	lbs											8,450*	8,450*	
9.14 m	(kg)											3 832*	3 832*	
+25' 0"	lbs											7,850*	7,850*	
7.62 m	(kg)											3 560*	3 560*	
+20' 0"	lbs							13,300*	12,150			7,600*	7,600*	
6.10 m	(kg)							6 032*	5 511			3 447*	3 447*	
+15' 0"	lbs					17,350*	16,950*	15,700*	11,850	9,600*	8,500	7,700*	7,150	
4.57 m	(kg)					7 869*	7 688*	7 121*	5 375	4 354*	3 856	3 492*	3 243	
+10' 0"	lbs	39,200*	39,200*	26,200*	25,500*	20,300*	16,250	17,200*	11,350	13,000	8,300	7,950*	6,650	
3.05 m	(kg)	17 781*	17 781*	11 884*	11 566*	9 208*	7 371	7 801*	5 148	5 897	3 765	3 606*	3 016	
+5' 0"	lbs	18,200*	18,200*	33,350*	23,600	23,200*	15,300	17,050	10,850	12,700	8,050	8,500*	6,550	
1.52 m	(kg)	8 255*	8 255*	15 127*	10 705	10 523*	6 940	7 734	4 922	5 761	3 651	3 855*	2 971	
Ground Line	lbs	19,800*	19,800*	35,700*	22,300	23,600	14,500	16,600	10,400	12,450	7,800	9,350*	6,750	
	(kg)	8 981*	8 981*	16 193*	10 115	10 705	6 577	7 530	4 717	5 647	3 538	4 241*	3 062	
-5' 0"	lbs	25,600*	25,600*	35,750*	21,850	23,100	14,100	16,300	10,100	12,350	7,700	10,750*	7,400	
-1.52 m	(kg)	11 612*	11 612*	16 216*	9 911	10 478	6 396	7 394	4 581	5 602	3 493	4 876*	3 357	
-10' 0"	lbs	34,000*	34,000*	34,100*	21,950	23,050	14,050	16,250	10,050			13,200*	8,800	
3.05 m	(kg)	15 422*	15 422*	15 467*	9 957	10 455	6 373	7 371	4 559			5 987*	3 992	
-15' 0"	lbs	42,000*	42,000*	29,850*	22,350	22,150*	14,250					11,700*	11,700*	
4.57 m	(kg)	19 051*	19 051*	13 539*	10 138	10 047*	6 464					5 307*	5 307*	
-20' 0"	lbs	29,100*	29,100*	21,100*	21,100*									
6.10 m	(kg)	13 199*	13 199*	9 570*	9 570*									

8' 8" (2.65 m) Arm with 20' 2" (6.15 m) Boom and 1,914 lb. (868 kg) Bucket with Power-Boost Applied

		Radius of Load										Cap. at Max. Reach		
		10' 0" (3.05 m)		15' 0" (4.57 m)		20' 0" (6.10 m)		25' 0" (7.62 m)		30' 0" (9.14 m)		End	Side	
		End	Side	End	Side	End	Side	End	Side	End	Side	End	Side	
+25' 0"	lbs											9,950*	9,950*	
7.62 m	(kg)											4 513*	4 513*	
+20' 0"	lbs							14,450*	11,850			9,650*	8,750	
6.10 m	(kg)							6 554*	5 375			4 377*	3 969	
+15' 0"	lbs					18,750*	16,900	16,700*	11,650			9,700*	7,700	
4.57 m	(kg)					8 505*	7 666	7 575*	5 284			4 400*	3 493	
+10' 0"	lbs			29,150*	25,000	21,500*	15,950	17,450	11,200	12,400*	8,200	10,050*	7,150	
3.05 m	(kg)			13 222*	11 340	9 752*	7 235	7 915	5 080	5 624*	3 720	4 559*	3 243	
+5' 0"	lbs			33,500*	23,100	24,100*	15,050	16,950	10,700	12,650	8,000	10,650*	7,050	
1.52 m	(kg)			15 195*	10 478	10 931*	6 827	7 689	4 854	5 738	3 629	4 831*	3 198	
Ground Line	lbs	18,450*	18,450*	35,750*	22,050	23,450	14,400	16,500	10,350	12,450	7,800	11,650	7,300	
	(kg)	8 368*	8 368*	16 216*	10 002	10 637	6 532	7 484	4 695	5 647	3 538	5 284	3 311	
-5' 0"	lbs	26,350*	26,350*	35,400*	21,950	23,100	14,100	16,300	10,150			12,900	8,100	
-1.52 m	(kg)	11 952*	11 952*	16 057*	9 957	10 478	6 396	7 394	4 604			5 851	3 674	
-10' 0"	lbs	37,500*	37,500*	32,900*	22,150	23,150	14,150	16,350	10,200			14,650*	9,900	
3.05 m	(kg)	17 010*	17 010*	14 923*	10 047	10 501	6 418	7 416	4 627			6 645*	4 491	
-15' 0"	lbs	37,550*	37,550*	27,450*	22,700	20,200*	14,500							
4.57 m	(kg)	17 032*	17 032*	12 451*	10 297	9 162*	6 577							

12' 0" (3.66 m) Arm with 20' 2" (6.15 m) Boom and 1,741 lb. (790 kg) Bucket with Power-Boost Applied

		Radius of Load										Cap. at Max. Reach		
		10' 0" (3.05 m)		15' 0" (4.57 m)		20' 0" (6.10 m)		25' 0" (7.62 m)		30' 0" (9.14 m)		End	Side	
		End	Side	End	Side	End	Side	End	Side	End	Side	End	Side	
+30' 0"	lbs											7,100*	7,100*	
9.14 m	(kg)											3 221*	3 221*	
+25' 0"	lbs							9,650*	9,650*			6,550*	6,550*	
7.62 m	(kg)							4 377*	4 377*			2 971*	2 971*	
+20' 0"	lbs							12,400*	12,200*			6,350*	6,350*	
6.10 m	(kg)							5 624*	5 533*			2 880*	2 880*	
+15' 0"	lbs							14,600*	11,950	10,950*	8,600	6,400*	6,400*	
4.57 m	(kg)							6 622*	5 421	4 966*	3 901	2 903*	2 903*	
+10' 0"	lbs	19,100*	19,100*	24,000*	24,000*	18,900*	16,500	16,200*	11,450	13,050	8,350	6,600*	6,100	
3.05 m	(kg)	8 663*	8 663*	10 886*	10 886*	8 573*	7 484	7 348*	5 194	5 919	3 788	2 994*	2 767	
+5' 0"	lbs	23,950*	23,950*	31,050*	24,000	22,050*	15,400	17,100	10,850	12,700	8,000	7,000*	5,950	
1.52 m	(kg)	10 863*	10 863*	14 084*	10 886	10 001*	6 985	7 757	4 922	5 761	3 629	3 175*	2 699	
Ground Line	lbs	20,150*	20,150*	34,900*	22,350	23,650	14,500	16,550	10,350	12,400	7,750	7,700*	6,100	
	(kg)	9 140*	9 140*	15 830*	10 138	10 728	6 577	7 507	4 695	5 625	3 515	3 493*	2 767	
-5' 0"	lbs	23,950*	23,950*	35,600*	21,650	23,000	14,000	16,150	10,000	12,200	7,550	8,750*	6,650	
-1.52 m	(kg)	10 863*	10 863*	16 148*	9 820	10 433	6 350	7 326	4 536	5 534	3 425	3 969*	3 016	
-10' 0"	lbs	30,600*	30,600*	34,600*	21,600	22,800	13,800	16,050	9,900	12,150*	7,550	10,550*	7,750	
3.05 m	(kg)	13 880*	13 880*	15 694*	9 798	10 342	6 260	7 280	4 491	5 511*	3 425	4 785*	3 515	
-15' 0"	lbs	42,600*	42,600*	31,300*	21,950	22,900	13,950	16,200	10,000			12,950*	10,200	
4.57 m	(kg)	19 323*	19 323*	14 197*	9 957	10 387	6 328	7 348	4 536			5 874*	4 627	
-20' 0"	lbs	34,100*	34,100*	24,350*	22,450	17,250*	14,500							
6.10 m	(kg)	15 467*	15 467*	11 045*	10 183	7 824*	6 577							

# 290 X2 Specifications

## Bucket Sizes

Bucket Type	SAE Heaped Capacity		Width Outside Lip		Bucket Weight		Number of Teeth	Arm Length		
	(yd³)	(m³)	(in)	(mm)	(lbs)	(kg)		8'-8" 2.65m	10'-5" 3.18m	12'-0" 3.66m
STDP	0.80	0.61	24	610	1285	583	3	H	H	H
	1.06	0.81	30	762	1458	661	4	H	H	H
	1.33	1.02	36	914	1630	739	5	H	H	H
	1.61	1.23	42	1067	1774	805	5	H	H	M
	1.89	1.45	48	1219	1918	870	5	M	M	L
	2.16	1.65	54	1372	2091	948	6	M	L	L
	2.43	1.86	60	1524	2239	1016	6	L	L	N/A
HDP	0.80	0.61	24	610	1498	679	3	H	H	H
	1.06	0.81	30	762	1705	773	4	H	H	H
	1.33	1.02	36	914	1873	850	4	H	H	H
	1.61	1.23	42	1067	2080	943	5	H	H	M
	1.89	1.45	48	1219	2247	1019	5	M	M	L
	2.16	1.65	54	1372	2454	1113	6	M	L	L
	2.43	1.86	60	1524	2621	1189	6	L	L	N/A
XDP	0.79	0.60	24	610	2230	1012	3	H	H	H
	1.05	0.80	30	762	2528	1147	4	H	H	H
	1.32	1.01	36	914	2749	1247	4	H	H	H
	1.59	1.22	42	1067	3047	1382	5	H	H	M
	1.87	1.43	48	1219	3267	1482	5	M	M	L
	2.15	1.64	54	1372	3565	1617	6	L	L	N/A
	2.43	1.86	60	1524	3786	1717	6	L	L	N/A
POWER BUCKETS	0.76	0.58	24	610	3025	1372	3	H	H	H
	0.98	0.75	30	762	3283	1489	4	H	H	H
	1.21	0.93	36	914	3392	1539	4	H	H	H
	1.44	1.10	42	1067	3552	1611	5	H	M	M
	1.68	1.28	48	1219	3709	1682	5	M	M	L
	1.91	1.46	54	1372	3920	1778	6	L	L	N/A
DITCH	1.30	0.99	60	1524	1767	802	0	H	H	H
	1.45	1.11	66	1676	1928	875	0	H	H	H
	1.59	1.22	72	1829	2034	923	0	H	H	M

STDP - Standard duty plate  
HDP - Heavy duty plate  
XDP - Extreme duty plate  
POWER - HDP for use with ESCO multi-pin grabber only

Approval Code For Arm/Bucket Combinations	
H.....	Heavy material (up to 3,370 lbs./yd³)
M.....	Medium material (up to 2,700 lbs./yd³)
L.....	Light material (up to 2,020 lbs./yd³)
N/A.....	Not applicable

## Standard Equipment

- KAB 815 sliding/reclining suspension seat with adjustable 4-inch armrests, lumbar support and retractable seat belt
- Safety glass front window with auto lock, windshield wiper and washer with intermittent speeds, Lexan® side and rear tinted windows
- 4-position tilting consoles with memory position and hydraulic lock-out
- Auto climate control a/c and heat
- AM/FM stereo with mute button, horn, interior light, digital clock, hour meter, floor mat, cup holder, sun shade, storage, LH and RH rear view mirrors
- Single pedal travel
- Travel alarm with cancel switch
- Vandal guarding with bolt-on FOG capability
- EPA Tier III Isuzu diesel engine
- Common rail fuel injection
- Turbocharger with intercooler
- Neutral safety start
- Idle start
- Glow plug pre-heat
- Auto engine warm-up
- Auto idling system
- One-touch idle
- Dual remote fuel filters with water separation
- Double element air filter with in-cab restriction indicator
- External fuel gauge
- Remote, full-flow engine oil filter
- Green plug engine oil drain
- EPF Engine Protection
- Emergency engine stop
- Open-center hydraulic system
- Four selectable work modes including attachment mode
- Auto power boost
- Auto swing priority
- Pre-set auxiliary pump settings - 10
- Auxiliary valve
- Stackable main control valve
- Auxiliary pipe brackets
- Control levers pre-wired for auxiliary
- Control pattern changer
- Long undercarriage
- Sealed and lubricated track chain
- Two-speed with auto shift and straight travel
- Planetary drive
- Spring-applied, hydraulic release brake
- Hydraulic track adjust
- Swivel guard belly pan
- Track guide
- Vandal locks with common key
- 11,905 lb (5,419 kg) counterweight with lifting eyes
- 20-ft 2-in boom
- EMS (Extended Maintenance System) 1,000 hour service interval throughout entire attachment except bucket
- Attachment cushion valve
- Arm and boom speed assistance
- Arm and boom regeneration
- Arm and boom holding valves
- Cylinder cushion
- Centralized lube bank
- Bucket anti-clatter device
- Illuminated LCD service monitor
- On-board diagnostic system
- Anti-theft device
- 12-volt accessory outlet
- 70-watt work lights on boom and upper

## Options

- Arms
  - 10-ft 5-in (3.18 m)
  - 8-ft 8-in (2.65 m)
  - 12-ft 0-in (3.66 m)
- Tracks
  - 31.5-in (800 mm) 3-bar grouser
  - 27.5-in (700 mm) 3-bar grouser
- Hydraulics
  - Single-acting with switch or pedal activation
  - Multi-function with switch or pedal activation and in-cab flow direction control
  - Thumb hydraulics with switch activation
  - 2nd and 3rd auxiliary with pedal activation
- Couplers
  - ESCO multi-pin grabber
  - Dromone automatic quick-coupler
- Thumbs
  - ESCO Universal rigid
  - ESCO Hydraulic non-link
  - ESCO Hydraulic non-link for coupler
  - ESCO Hydraulic link
  - ESCO Hydraulic link for coupler
- Cab lights - exterior
- Air-suspension seat
- Free Swing
- Cyclone pre-clean air filter
- FOG guard
- Front guard - mesh or bars
- Attachment reinforcement plating
- HD bucket linkage
- Track guides - triple

## Notes: Excavator lifting capacities

- Lifting capacities shown should not be exceeded. Weight of all lifting accessories must be deducted from the above lifting capacities.
- Lifting capacities are based on machine standing on firm, uniform supporting surface. User must make allowances for job conditions such as soft or uneven ground.
- Lifting capacities shown do not exceed 75% of minimum tipping loads or 87% of hydraulic capacities. **Capacities marked with an asterisk (\*) are limited by hydraulic capacities.**
- Least stable position is over the side.
- Operator should be fully acquainted with the Operator's Manual & Operating Safety Booklet, furnished by LBX before operating the machine.
- Capacities apply only to the machine as originally manufactured and normally equipped by LBX Company, LLC.
- Lift capacity ratings are based on SAE J1097, "Earthmoving Machinery - Hydraulic Excavators - Lift Capacity."

# Link-Belt

EXCAVATORS • FORESTRY  
DEMOLITION • MATERIAL HANDLING

LBX Company is the proud maker of quality Link-Belt excavators and is located in Lexington, KY.

**LBX**  
"Different by Design"  
www.lbxco.com

Litho in USA 8/11 #LBX2167 (supersedes #LBX2135)

© LBX and © Link-Belt are registered trademarks. Copyright 2010. All rights reserved. We are constantly improving our products and therefore reserve the right to change designs and specifications.