

LONG FRONT 290X₂

specifications

Operating Weight: 65,700 lbs. (29 800 kg)

SAE Net Horsepower: 207 HP (154 kW)

Bucket Range: .69 - 2.43 yd³ (.53 - 1.86 m³)

Engine

Isuzu AH-6HK1XYSS Tier 3 turbocharged diesel engine with electronic fuel control, 6-cylinder, water-cooled, EGR with cooler, air-to-air intercooler, fuel cooler, auto idle start, neutral safety start, glow plugs, auto warm-up, EPF engine protection, dual stage fuel filtration, remote oil filter, green plug oil drain.

SAE net horsepower 207 HP (154 kW) @ 1,800 rpm
Displacement 7.8 L
Maximum torque 627 lbf-ft (850 N-m) @ 1,500 rpm
Starter 24V-5.0kW
Alternator 50 amp
Battery 128 amp hours

Cab and Controls

Pressurized cab with climate control a/c and heat with defroster, LCD monitor, illuminated soft-touch switches, low-effort controls pre-wired for auxiliary hydraulics, control pattern changer, single pedal travel, sliding LEXAN® MARGARD® windows, safety glass front window with automatic locking system and vandal cover, intermittent windshield wiper with washer, emergency rear window exit, polycarbonate roof hatch with sunshade, shockless cab suspension with four fluid mountings, KAB® reclining suspension seat, sliding 4-position tilting control consoles, AM/FM radio, digital clock, dome light, seat belt, coat hook, cup holder, storage compartments, floor mat, footrests, ashtray, 24-volt cigarette lighter, 12-volt outlet, travel alarm, handrail, mirrors.

Four selectable working modes, anti-theft password protection system, on-board self-diagnostic system with memory, auto-idling system, one-touch decelerator, auto power boost, gate lock safety shutoff.

A/C output 18,100 BTU/hr
Heater output 20,150 BTU/hr
Sound level (inside cab) 70.5 dB(A)
Sound level (exterior) 99.7 dB(A)

Hydraulic System

Open-center system, two variable displacement axial piston pumps and one gear pump for pilot controls, main control valve with one 4-spool valve and one 5-spool valve with auxiliary spool - stackable, oil cooler, auto power boost, boom and arm holding valves, o-ring face seals, 6 micron return filter, firewall.

Hydraulic Pumps

Maximum flow 2 x 64.2 gpm (2 x 243 l/min)
Pilot pump maximum flow 7.1 gpm (27 l/min)

Relief Valve Settings

Boom/arm/bucket 4,970 psi (343 bar)
in Power-Boost Mode 5,400 psi (373 bar)
Swing circuit 4,260 psi (294 bar)
Travel 4,970 psi (343 bar)

Hydraulic Oil Filtration

Return filter 6 micron
Pilot filter 8 micron
Suction screen 150 micron



Swing

Planetary reduction powered by axial piston motor. Internal ring gear with grease cavity for swing pinion. Swing bearing is single-row shear type ball bearing. Mechanical disc swing brake. Auto power swing.

Swing speed 0 - 10.2 rpm
Tail swing 10' 4" (3.16 m)
Swing torque 68,224 lbf-ft. (92.5 kN•m)

Undercarriage

X Pattern carbody with 15' 11" (4.85 m) LC long undercarriage by 8' 6" (2.6 m) track gauge, sealed and strutted track chain with track guide, sealed rollers and idlers, two-speed independent hydrostatic travel with compact planetary final drive, disc type brakes, adjustable track tension, swivel guard.

Carrier rollers 2 per side
Track rollers 9 per side
Track link pitch 7.99" (203 mm)
Shoes 50 per side
Shoe width 31.5" (800 mm)
Ground pressure 6.24 psi (.43 bar)

Lubricant and Coolant Capacity

Fuel tank 118.88 gal. (450 liters)
Hydraulic tank 38.8 gal. (147 liters)
Hydraulic system 79.25 gal. (300 liters)
Final drive (per side) 2.4 gal. (9.1 liters)
Swing drive 1.59 gal. (6 liters)
Engine oil 10.04 gal. (38 liters)
Cooling system 7.66 gal. (29 liters)

Travel System

Two-speed independent hydrostatic travel with compact axial piston motors. Hydraulic motor powered output shaft coupled to a planetary reduction unit and track sprocket. All hydraulic components mounted within the width of side frame. Automatic downshift. Single pedal travel. Spring applied, hydraulically released disc parking brake built into each motor. Each travel motor equipped with counterbalance valve to prevent overspeeding down an incline.

Max. travel speed 2.0 - 3.5 mph (3.2 - 5.6 km/h)
Drawbar pull 52,380 lbf (233 kN)
Gradeability 70% (35°)

Attachment

Boom 35' 10" (10.9 m)
Arm 25' 6" (7.77 m)

Fuel Usage*

Heavy 5.73 gal / hr (21.68 liter / hr)
Average 4.65 gal / hr (17.61 liter / hr)
Light 3.81 gal / hr (14.42 liter / hr)

*Fuel economy varies widely depending on application. "Heavy" represents nearly continuous operation in tough digging applications in SP Mode. "Light" represents easy digging applications utilizing the machine about 50% of the time in SP Mode.

290 X2 LF Specifications

Working Ranges

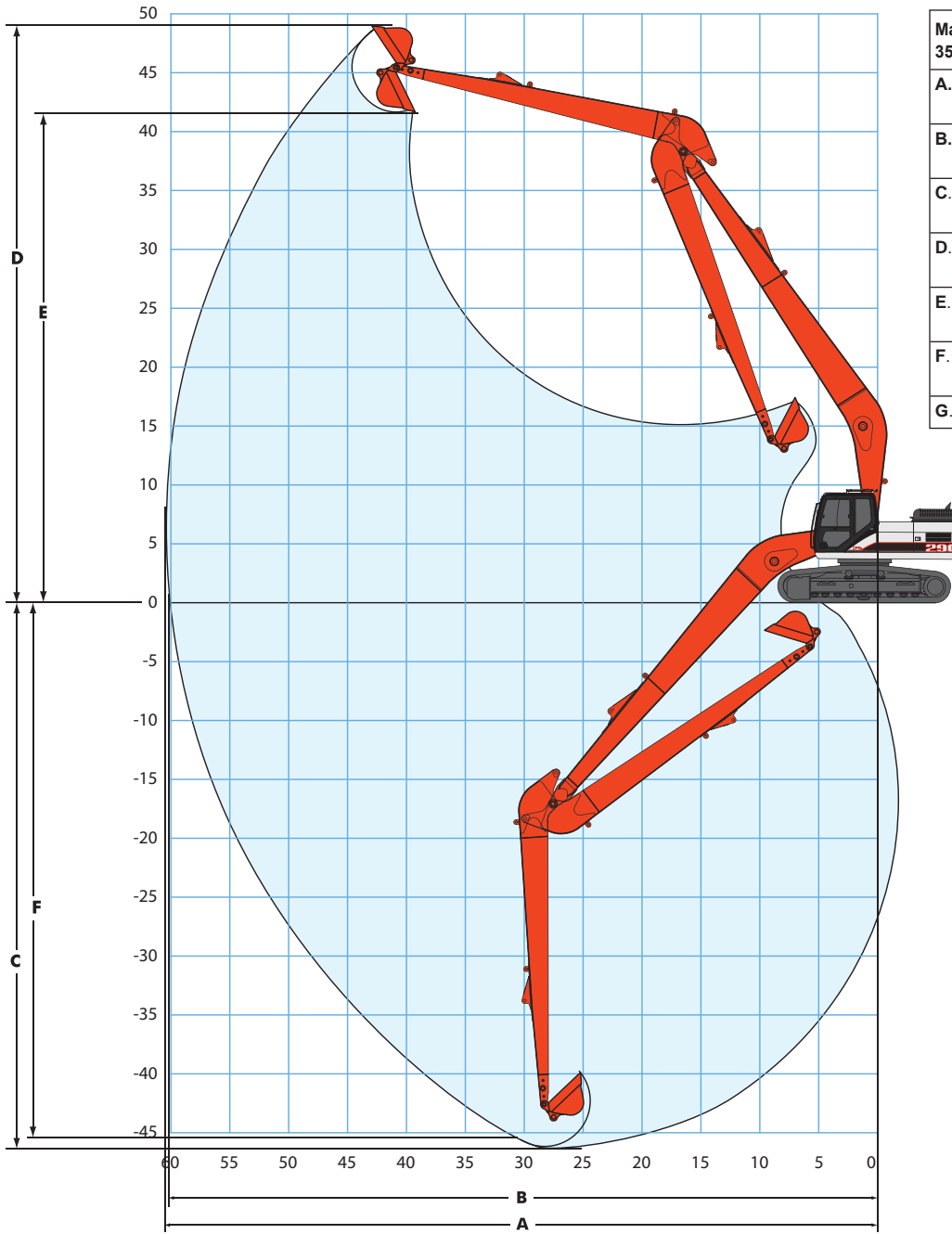

Machine equipped with 35' 10" (10.9 m) boom	25' 6" Arm (7.77 m)
A. Maximum reach	60' 7" (18.5 m)
B. Maximum reach @ ground level	60' 3" (18.36 m)
C. Maximum dig depth	46' 4" (14.12 m)
D. Maximum dig height	48' 9" (14.86 m)
E. Maximum dump height	41' 10" (12.75 m)
F. Digging depth - 8' (2.44 m) level bottom	45' 10" (13.97 m)
G. Bucket rotation	172°

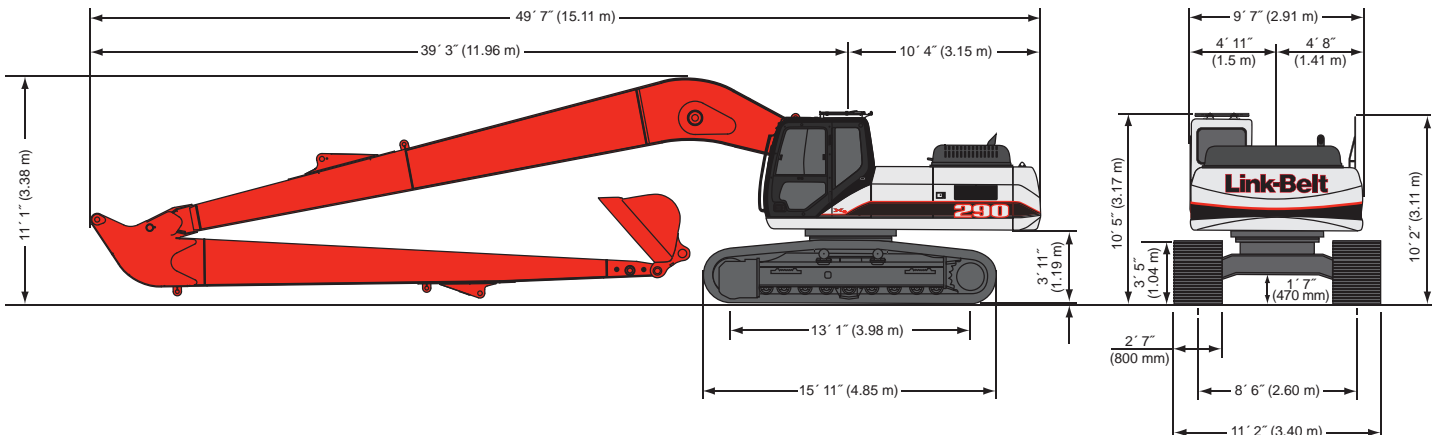

290 X2 LF Specifications

Lifting Capacities

25' 6" (7.77 m) Arm with 35' 10" (10.9 m) Boom and 1,100 lb. (499 kg) Bucket with Power-Boost Applied

		Radius of Load															
		5' 0" (1.52 m)		10' 0" (3.05 m)		15' 0" (4.57 m)		20' 0" (6.10 m)		25' 0" (7.62 m)		30' 0" (9.14 m)		35' 0" (10.66 m)		40' 0" (12.19 m)	
		End	Side	End	Side	End	Side	End	Side	End	Side	End	Side	End	Side	End	Side
+40' 0"	lbs																
12.19 m	(kg)																
+35' 0"	lbs																
10.66 m	(kg)																
+30' 0"	lbs																
9.14 m	(kg)																
+25' 0"	lbs															8,612	5,287
7.62 m	(kg)														(3,906)	(2,398)	
+20' 0"	lbs													10,633	6,633	8,250	4,945
6.10 m	(kg)												(4,823)	(3,009)	(3,742)	(2,243)	
+15' 0"	lbs											13,121	8,144	10,020	6,058	7,831	4,549
4.57 m	(kg)										(5,952)	(3,694)	(4,545)	(2,748)	(3,552)	(2,063)	
+10' 0"	lbs					37,142	20,523	23,200	13,726	16,288	9,791	12,142	7,239	9,372	5,452	7,387	4,129
3.05 m	(kg)					(9,309)	(10,523)	(6,226)	(7,388)	(4,441)	(5,508)	(3,284)	(4,251)	(2,473)	(3,351)	(1,873)	
+5' 0"	lbs					16,586	20,726	11,563	14,839	8,480	11,217	6,385	8,749	4,869	6,956	3,722	
1.52 m	(kg)					(7,523)	(9,401)	(5,245)	(6,731)	(3,846)	(5,088)	(2,896)	(3,969)	(2,209)	(3,155)	(1,688)	
Ground	lbs					14,826	19,061	10,107	13,709	7,457	10,442	5,669	8,207	4,361	6,572	3,358	
Line	(kg)					(6,725)	(8,646)	(4,584)	(6,218)	(3,382)	(4,736)	(2,571)	(3,723)	(1,978)	(2,981)	(1,523)	
-5' 0"	lbs			76,276	30,276	29,488	14,292	18,158	9,318	12,954	6,774	9,867	5,138	7,780	3,961	6,260	3,063
-1.52 m	(kg)			(13,733)	(13,375)	(6,483)	(8,236)	(4,227)	(5,876)	(3,073)	(4,475)	(2,331)	(3,529)	(1,797)	(2,839)	(1,389)	
-10' 0"	lbs	196,465	490,269	77,050	30,773	29,470	14,278	17,781	8,988	12,531	6,390	9,497	4,796	7,485	3,685	6,036	2,852
3.05 m	(kg)	(89,115)	(222,382)	(34,949)	(13,958)	(13,367)	(6,476)	(8,065)	(4,077)	(5,684)	(2,898)	(4,308)	(2,175)	(3,395)	(1,671)	(2,738)	(1,294)
-15' 0"	lbs	195,848	487,951	78,194	31,507	29,780	14,530	17,741	8,953	12,366	6,241	9,311	4,624	7,320	3,531	5,909	2,732
4.57 m	(kg)	(88,835)	(221,330)	(35,468)	(14,291)	(13,508)	(6,591)	(8,047)	(4,061)	(5,609)	(2,831)	(4,223)	(2,097)	(3,320)	(1,602)	(2,680)	(1,239)
-20' 0"	lbs	197,847	495,467	79,709	32,480	30,320	14,970	17,934	9,122	12,404	6,275	9,287	4,602	7,282	3,495	5,882	2,706
6.10 m	(kg)	(89,741)	(224,740)	(36,155)	(14,732)	(13,753)	(6,790)	(8,135)	(4,138)	(5,626)	(2,846)	(4,213)	(2,087)	(3,303)	(1,585)	(2,668)	(1,227)
-25' 0"	lbs	201,415	508,882	81,632	33,714	31,068	15,578	18,315	9,455	12,609	6,461	9,406	4,712	7,366	3,574	5,961	2,781
7.62 m	(kg)	(91,369)	(230,825)	(37,027)	(15,292)	(14,092)	(7,066)	(8,308)	(4,289)	(5,719)	(2,930)	(4,266)	(2,137)	(3,341)	(1,621)	(2,704)	(1,261)
-30' 0"	lbs			84,029	35,252	32,034	16,365	18,871	9,941	12,970	6,788	9,666	4,952	7,577	3,771	6,161	2,970
9.14 m	(kg)			(15,990)	(14,530)	(7,423)	(8,560)	(4,509)	(5,883)	(3,079)	(4,384)	(2,246)	(3,437)	(1,710)	(2,795)	(1,347)	
-35' 0"	lbs			87,003	37,162	33,258	17,361	19,619	10,595	13,498	7,266	10,079	5,334	7,940	4,111		
10.66 m	(kg)			(16,856)	(15,086)	(7,875)	(8,899)	(4,805)	(6,123)	(3,296)	(4,572)	(2,419)	(3,602)	(1,865)			
-40' 0"	lbs							20,642	11,464	14,240	7,937	10,703	5,910				
12.19 m	(kg)							(5,200)	(6,459)	(3,600)	(4,855)	(2,681)					

25' 6" (7.77 m) Arm with 35' 10" (10.9 m) Boom and 1,100 lb. (499 kg) Bucket with Power-Boost Applied

		Radius of Load					
		45' 0" (13.72 m)		50' 0" (15.24 m)		55' 0" (16.76 m)	
		End	Side	End	Side	End	Side
+40' 0"	lbs	6,985	4,149				
12.19 m	(kg)	(3,168)	(1,882)				
+35' 0"	lbs	7,006	4,169				
10.66 m	(kg)	(3,178)	(1,891)				
+30' 0"	lbs	6,912	4,080	5,876	2,921		
9.14 m	(kg)	(3,135)	(1,851)	(2,665)	(1,325)		
+25' 0"	lbs	6,732	3,909	5,280	2,829		
7.62 m	(kg)	(3,054)	(1,773)	(2,395)	(1,283)		
+20' 0"	lbs	6,488	3,676	5,126	2,682	4,028	1,868
6.10 m	(kg)	(2,943)	(1,667)	(2,325)	(1,217)	(1,827)	(847)
+15' 0"	lbs	6,201	3,403	4,935	2,499	3,917	1,762
4.57 m	(kg)	(2,813)	(1,544)	(2,238)	(1,134)	(1,777)	(799)
+10' 0"	lbs	5,894	3,111	4,727	2,300	3,788	1,638
3.05 m	(kg)	(2,673)	(1,411)	(2,144)	(1,043)	(1,718)	(743)
+5' 0"	lbs	5,593	2,824	4,521	2,103	3,657	1,512
1.52 m	(kg)	(2,537)	(1,281)	(2,051)	(954)	(1,659)	(686)
Ground	lbs	5,321	2,565	4,334	1,924	3,540	1,400
Line	(kg)	(2,414)	(1,163)	(1,966)	(873)	(1,606)	(635)
-5' 0"	lbs	5,098	2,353	4,183	1,779	3,453	1,316
-1.52 m	(kg)	(2,312)	(1,067)	(1,897)	(807)	(1,566)	(597)
-10' 0"	lbs	4,938	2,201	4,082	1,682		
3.05 m	(kg)	(2,240)	(998)	(1,852)	(763)		
-15' 0"	lbs	4,853	2,120	4,043	1,646		
4.57 m	(kg)	(2,201)	(962)	(1,834)	(747)		
-20' 0"	lbs	4,853	2,119	4,085	1,686		
6.10 m	(kg)	(2,201)	(961)	(1,853)	(765)		
-25' 0"	lbs	4,951	2,213				
7.62 m	(kg)	(2,246)	(1,004)				
-30' 0"	lbs						
9.14 m	(kg)						
-35' 0"	lbs						
10.66 m	(kg)						
-40' 0"	lbs						
12.19 m	(kg)						

290 X2 LF Specifications

Standard Equipment

- KAB 815 sliding/reclining suspension seat with adjustable 4-inch armrests, lumbar support and retractable seat belt
- Safety glass front window with auto lock, windshield wiper and washer with intermittent speeds, Lexan® side and rear tinted windows
- 4-position tilting consoles with memory position and hydraulic lock-out
- Auto climate control a/c and heat
- AM/FM stereo with mute button, horn, interior light, digital clock, hour meter, floor mat, cup holder, sun shade, storage, LH and RH rear view mirrors
- Single pedal travel
- Travel alarm with cancel switch
- Vandal guarding with bolt-on FOG capability
- EPA Tier III Isuzu diesel engine
- Common rail fuel injection
- Turbocharger with intercooler
- Neutral safety start
- Idle start
- Glow plug pre-heat
- Auto engine warm-up
- Auto idling system
- One-touch idle
- Dual remote fuel filters with water separation
- Double element air filter with in-cab restriction indicator
- External fuel gauge
- Remote, full-flow engine oil filter
- Green plug engine oil drain
- EPF Engine Protection
- Emergency engine stop
- Open-center hydraulic system
- Four selectable work modes including attachment mode
- Auto power boost
- Auto swing priority
- Pre-set auxiliary pump settings - 10
- Auxiliary valve
- Stackable main control valve
- Auxiliary pipe brackets
- Control levers pre-wired for auxiliary
- Control pattern changer
- Long undercarriage
- Sealed and lubricated track chain
- Two-speed with auto shift and straight travel
- Planetary drive
- Spring-applied, hydraulic release brake
- Hydraulic track adjust
- Swivel guard belly pan
- Track guide
- Vandal locks with common key
- Hand rail
- Tool box
- 35-ft 10-in boom
- Attachment cushion valve
- Arm and boom speed assistance
- Arm and boom regeneration
- Arm and boom holding valves
- Cylinder cushion
- Centralized lube bank
- Bucket anti-clatter device
- Illuminated LCD service monitor
- On-board diagnostic system
- Anti-theft device
- 12-volt accessory outlet
- 70-watt work lights on boom and upper

Options

- Arms to convert to standard excavator (requires counterweight conversion)
 - 10-ft 5-in (3.18 m)
 - 8-ft 8-in (2.65 m)
 - 12-ft 0-in (3.66 m)
- Tracks
 - 31.5-in (800 mm) 3-bar grouser
 - 27.5-in (700 mm) 3-bar grouser
- Hydraulics
 - Double-acting auxiliary hydraulics (not for hammer use)
- Cab lights - exterior
- Air-suspension seat
- Free Swing
- Cyclone pre-clean air filter
- FOG guard
- Front guard - mesh or bars
- HD bucket linkage
- Track guides - triple

Notes: Excavator lifting capacities

1. Lifting capacities shown should not be exceeded. Weight of all lifting accessories must be deducted from the above lifting capacities.
2. Lifting capacities are based on machine standing on firm, uniform supporting surface. User must make allowances for job conditions such as soft or uneven ground.
3. Lifting capacities shown do not exceed 75% of minimum tipping loads or 87% of hydraulic capacities. **Capacities marked with an asterisk (*) are limited by hydraulic capacities.**
4. Least stable position is over the side.
5. Operator should be fully acquainted with the Operator's Manual & Operating Safety Booklet, furnished by LBX before operating the machine.
6. Capacities apply only to the machine as originally manufactured and normally equipped by LBX Company LLC.
7. Lift capacity ratings are based on SAE J1097, "Earthmoving Machinery – Hydraulic Excavators – Lift Capacity."



LBX Company is the proud maker of quality Link-Belt excavators and is located in Lexington, KY.

Litho in USA 3/08 #LBX2150

© LBX and © Link-Belt are registered trademarks. Copyright 2008. All rights reserved. We are constantly improving our products and therefore reserve the right to change designs and specifications.



www.lbxco.com