

Specifications

Rough Terrain Crane

RTC-8030 Series II

30-ton (27.2 metric ton)

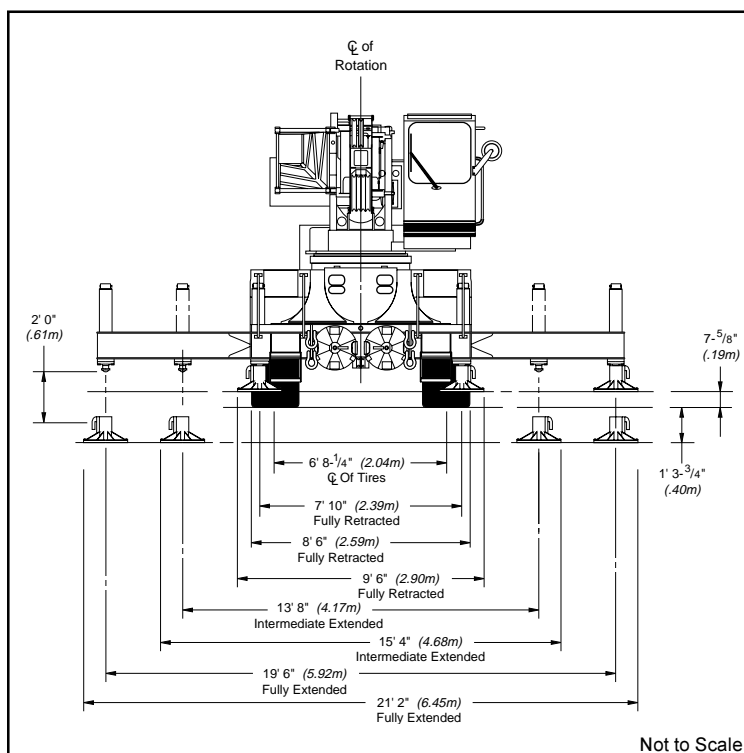
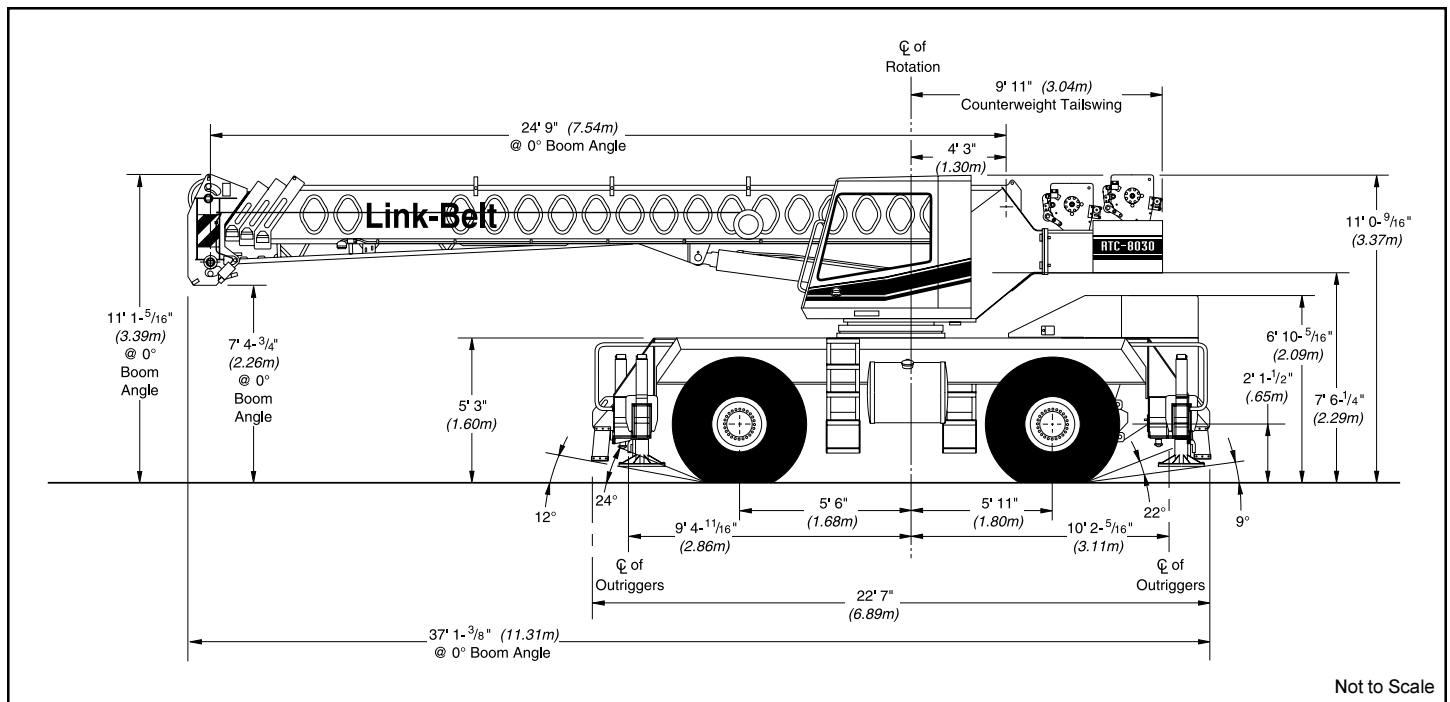

General dimensions	feet	meters
Turning radius (4-wheel steer - centerline of tires)	18' 4"	5.58
Turning radius (2-wheel steer - centerline of tires)	30' 3.5"	9.23

Upperstructure

■ Boom

Patented Design. Boom side plates have diamond shaped impressions for superior strength to weight ratio and 100,000 p.s.i. (689.5 MPa) steel angle chords for lateral stiffness. Boom telescope sections are supported by top, bottom and adjustable side wear shoes to prevent metal to metal contact.

Microguard 434, Rated Capacity Limiter "RCL" - Standard; Graphic audio-visual warning system built into dash with anti-two block and function limiters. Operating data available includes boom length, boom angle, head height, radius of load, machine configuration, allowed load, actual load and percent of allowed load. Presettable alarms for maximum and minimum boom angles, max. tip height, max. boom length, swing left/right positions. Operator defined area alarm is standard. Anti-two block weight designed for quick reeve of hookblock.

Optional; External/internal load rating bar graph for quick operator reference.

Standard Boom — 30' - 78' (9.14 - 23.78 m) three-section full power boom.

Optional Boom - 29' - 91' 4" (8.84 - 27.81 m) four-section full power boom. Two mode boom extension - Basic mode (or mode 'B') is the full power, synchronized mode of telescoping all sections proportionally. The exclusive **A-max** mode (or mode 'A') extends only the inner mid-section to 49' 9" (15.16 m) offering increased capacities for in-close, maximum capacity picks.

Boom head - Four 10-5/8" (0.27 m) root diameter steel sheaves handle up to seven parts of wire rope. Rope dead end lugs provided on each side of boom head. Easily removable wire rope guards are standard. Boom head designed for quick reeve of hookblock.

Auxiliary lifting sheave - *Optional;* Single 10-5/8" (0.27 m) root diameter steel sheave with removable wire rope guard. For use with one or two parts of line off the optional auxiliary winch. Does not affect erection of fly or use of main head sheaves for multiple reeving.

Boom elevation — One Link-Belt designed hydraulic cylinder with holding valve and bushing in each end. Hand control for controlling boom elevation from -3° to +78°.

■ Fly

Optional — 25' (7.62 m) fixed stowable one-piece lattice type.

Optional — 27' (8.23 m) offsettable stowable one-piece lattice type with lugs to allow for addition of second section. Can be offset 2°, 20°, or 40°.

Optional — 27' - 44' (8.23 - 13.41 m) offsettable stowable two-piece lattice type. Can be offset 2°, 20°, or 40°.

■ Cab and Controls

Environmental cab; isolated from sound and vibration by a neoprene seal. All windows are tinted and tempered safety glass. Sliding rear and right side windows and swing up roof window for maximum visibility and ventilation. Slide by door opens to 3' 0" (0.91 m) width. Six-way adjustable operator's seat with retractable seat belt. 4-way adjustable tilt/telescoping steering wheel. Hydraulic control levers (single-axis type) for swing, winches and boomhoist. Outrigger controls and sight level bubble also provided in upper cab. Foot controls for boom telescope, swing brake, service boom and engine throttle.

Cab instrumentation — Dash mounted gauges for hydraulic oil temperature, convertor temperature, oil pressure, water temperature, fuel and voltmeter.

■ Swing

Bi-directional hydraulic swing motor mounted to a planetary reducer for 360° continuous smooth swing at 2.8 r.p.m.

Swing park brake — 360°, mechanical disc brake mounted on the speed reducer. Mechanically controlled from the control console.

Swing brake — 360°, foot operated, spring released disc brake mounted on the speed reducer.

Swing lock — Standard; two position travel lock operated from the operator's cab.

Counterweight — Bolted to upperstructure frame. 7,800 lb. (3538 kg) cwt.

■ Hydraulic System

Main pump — 2-section gear-type pump. Combined pump capacity 75 gpm (284 lpm). Mounted on transmission converter, powered by engine. Pump operates at 3,500 p.s.i. (24.1 MPa) maximum system pressure. O-Ring Face Seal (ORFS) technology throughout with hydraulic oil cooler standard.

Telescope / outrigger / steering pump — Single gear-type pump, 18 gpm (83.2 lpm) maximum. Mounted on engine, powered by engine through a direct mechanical drive.

Pump operates at 3,000 p.s.i. (20.7 MPa) maximum system pressure.

Reservoir — 80 gallon (303 L) capacity. Diffuser for deaeration.

Filtration — Two 10-micron filters located outside hydraulic reservoir. Accessible for easy replacement.

Control valves — Five separate, pilot operated control valves allow simultaneous operation of all crane functions.

■ Load Hoist System

Standard — 2M rear winch with grooved lagging, two-speed motor and automatic brake; power up/down mode of operation. Bi-directional gear-type hydraulic motor, driven through a planetary reduction unit for positive operator control under all load conditions. Asynchronous parallel double crossover grooved drums minimize rope harmonic motion.

Optional — 2M front winch with two-speed motor and automatic brake, power up/down mode of operation.

Line pulls and speeds — Maximum line pull 11,948 lbs. (5420 kg) and maximum line speed of 452 f.p.m. (138 m/min) on standard 10.63" (0.27 m) root diameter grooved drum.

■ Additional Equipment — Standard

6 x 19 IWRC wire rope, controls for future addition of auxiliary winch, fire extinguisher, warning horn, mirrors, tilt/telescoping and locking steering wheel, drum rotation indicators, electric windshield wiper, windshield washer, circulating fan, cup holder, foot throttle with throttle lock, audio/visual warning system, tachometer, sun screen, backup alarm, top hatch window wiper, audible swing alarm, 12-volt accessory outlet, and travel lights.

■ Additional Equipment — Optional

360° swing lock (meets New York City requirements), hot water cab heater, 30-ton, 3-sheaves, quick reeve hook block, 8-1/2 ton hook ball, hoist drum cable followers, third wrap indicators, emergency steering system, air conditioning, amber strobe light, boom floodlight, mechanical boom angle indicator and rotation resistant rope, mechanical boom angle indicator, and pump disconnect

Carrier

■ Type

8' 6" (2.59 m) wide, 11' 5" (3.48 m) wheelbase.

4 x 4 x 4 — (4-wheel steer, 4-wheel drive) — For rough terrain with limited turning area.

Frame — 100,000 p.s.i. (689.5 MPa) steel, double walled construction with integral 100,000 p.s.i. (689.5 MPa) steel outrigger boxes.

■ Axles

Front- Heavy duty planetary drive/steer type.

Rear- Heavy duty planetary drive/steer type.

■ Suspension

Front axle - Rigid mounted to frame.

Rear axle - Fully independent 4-Link. Automatic axle oscillation lockout cylinders engage when upperstructure rotates past 2-1/2° of centerline.

■ Tires

Front and Rear

Standard — 20.5 x 25 (24-PR)
Earthmover type.

■ Brakes

Service — Fully hydraulic disc-type brakes at each wheel end with independent front and rear system.

Parking/emergency — Spring applied, hydraulic released, cab controlled, disc-type integral to the transmission.

■ Steering

Hydraulic front-wheel, four-wheel and "crab" steering: modes selected by toggle switch on dash. All modes fully controlled by steering wheel.

■ Transmission

Clark three-speed two range power shift transmission. Six speeds available forward and two reverse. Front axle disconnect for two or four-wheel drive.

■ Outriggers

Three position (fully extended, intermediate, and fully retracted) operation capability. Four hydraulic, telescoping beam and jack outriggers. Vertical jack cylinders equipped with integral holding valve. Beams extend to 19' 6" (5.94 m) centerline-to-centerline and retract to within 8' 6" (2.59 m) overall width. Equipped with stowable, lightweight 18.5" (0.47 m) diameter aluminum floats. Dash mounted controls and sight level bubble located in upperstructure cab.

Confined Area Lifting Capacities (CALC™) System - Outriggers may be extended to an intermediate position 13' 8" (4.17 m) for working in confined areas. In addition, capacities are available with the beams in the 7' 10" (2.39 m) fully retracted position. When the outrigger position levers (located on the outrigger boxes) are engaged, the operator can set the crane in the intermediate or fully retracted outrigger position without having to leave the cab.

■ Additional Equipment — Standard

Cab steps, four front and rear carrier steps, rear axle disconnect, non-skid safety strips on carrier deck (in upper), alarm, deep front storage, fenders, pontoon storage, full lighting package, 110 volt block heater, water/fuel separator on engine, front towing shackles and hook block tie back.

■ Additional Equipment — Optional

Rear Hydro-gas Ride™ suspension, rear steer indicator, ether injection package, spare tires and rims, and front and rear mounted pintle hook.

Engine	Cummins 6BT 5.9 L
Cylinders - cycle	6 - 4
Bore	4.02" (102.11 mm)
Stroke	4.72" (119.89 mm)
Displacement	359 cu. in. (5883 cm³)
Maximum brake hp	152@ 2500 rpm
Peak torque (ft. lb.)	414 @ 1500 rpm
Electric system	12 volt
Starting sytem	12 volt
Fuel capacity	75 gallons (283.9 L)
Alternator	130 amps
Crankcase capacity (total system)	17.3 qts. (16.37 L)

Travel speeds and gradeability

Engine	Tires	Maximum Speed		Gradeability at stall	Maximum tractive effort at stall		Gradeability at 1.0 mph (1.61 km/h)	Maximum tractive effort at 1.0 mph (1.61 km/h)	
		mph	km/h		pounds	kg		pounds	kg
Cummins 6BT5.9-C152	20.5 X 25	24.8	39.9	198.9%	46,769	21214	76.8%	32214	14612

■ Axle loads

Base machine with standard 30' to 78' (9.14 - 23.78 m) three-section boom, 2M main winch with 2-speed hoisting and power up/down, 450' (137 m) 5/8" (19 mm) wire rope, 4x4x4 carrier with Cummins 6BT5.9 engine, 20.5 x 25.0 tires, 75 gal. (283.91 L) of fuel, tow shackles and hookblock tieback.	G.V.W. ^①		Upper facing front				Upper facing rear			
			Front axle		Rear axle		Front axle		Rear axle	
		lbs.	kg	lbs.	kg	lbs.	kg	lbs.	kg	lbs.
	50,820	23052	25425	11533	25395	11519	31,307	14201	38,106	17285
Pintle hook, front and rear	40	18	20	9	20	9	20	9	20	9
Cold weather starting aids - ether injector	19	9	0	0	19	9	0	0	19	9
Pump disconnect	32	15	5	2	27	12	5	2	27	12
Hot water heater in operator's cab	35	16	15	7	20	9	21	10	14	6
Air conditioning in operator's cab	215	97	55	25	160	72	168	76	47	21
Emergency steer system	5	2	3	1	2	1	2	1	3	1
360 degree sector gear-type house lock	64	29	-3	14	33	15	35	43	29	13
Winch roller - rear winch	76	34	-14	-6	90	41	93	43	-17	-8
Power up/down winch with 450' (137 m) of rope-front	367	166	-28	-13	395	179	409	185	-42	-8
Winch roller-front winch	76	34	1	.5	75	34	78	35	-2	-1
Remove 450' (137 m) of wire rope from rear winch	-326	-148	84	38	-410	-186	-422	-191	96	44
Remove 450' (137 m) of wire rope from front winch	-326	-148	21	10	-347	-157	-359	-163	33	15
Replace three section boom w/ four section	1,564	687	1,901	681	13	6	69	32	1,445	665
Fly brackets to boom base sections for fly options	113	51	158	72	-46	-21	-41	-19	154	70
25' (7.62 m) fixed fly (stowed)	532	241	804	365	-272	-123	-252	-14	784	356
27' (8.23 m) offset fly (stowed)	951	431	1,634	741	-683	309	-648	-294	1,599	725
27' to 44' (8.23 to 13.41 m) offset fly (stowed)	1,369	621	2,270	1029	-901	408	-851	-386	2,220	1007
Floodlight to boom base section	10	4	25	11	-15	-7	-14	-6	24	11
Replace four sheave head machinery with three sheave	-20	-9	-54	-24	34	15	33	15	-53	-24
30-ton (27.2 mt) hookblock to carrier storage box	670	304	690	313	-20	-8	690	313	-20	-9
Hookball at carrier storage box	360	163	371	168	-11	-5	371	144	-11	-5
Auxiliary lifting sheave for 3-section boom	60	27	172	78	-112	-51	-109	-49	169	76
Auxiliary lifting sheave to 4-section boom	60	27	166	75	-106	-48	-104	-47	164	74

① Note: All weights are ± 3%

Lifting Capacities

Hydraulic Rough Terrain Crane

RTC-8030 Series II 30-ton (27.2 metric tons)

Four-Section Boom Capacities

Boom and Fly Capacities for this machine are listed by the following sections.

Fully Extended Outriggers

- Working Range Diagram
- 29' to 49' 9" Main Boom Capacities, "A-max" Mode
- 29' to 91' 3" Main Boom Capacities, Basic Mode "B"
- 25' Fly Capacities, Basic Mode "B"
- 27' to 44' Fly Capacities, Basic Mode "B"

On Tires

- Working Range Diagram
- 29' to 49' 9" Main Boom Capacities, "A-max" Mode
- 29' to 60' Main Boom Capacities, Basic Mode "B"

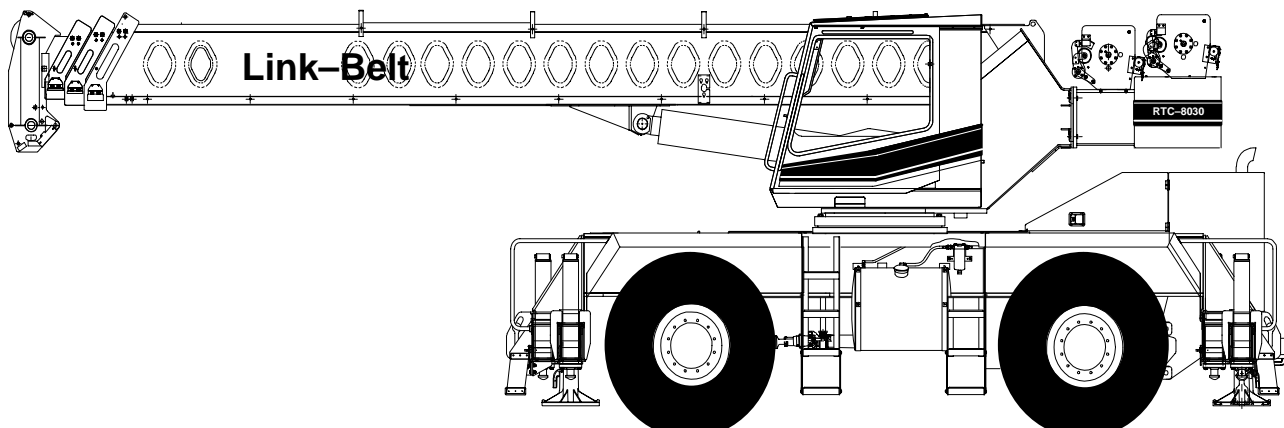

CAUTION: This material is supplied for reference use only. Operator must refer to in-cab Crane Rating Manual to determine allowable machine lifting capacities and operating procedures.



WARNING

READ AND UNDERSTAND THE OPERATOR'S AND SAFETY MANUALS AND THE FOLLOWING INSTRUCTIONS AND RATED LIFTING CAPACITIES BEFORE OPERATING CRANE. OPERATION WHICH DOES NOT FOLLOW THESE INSTRUCTIONS MAY RESULT IN AN ACCIDENT

OPERATING INSTRUCTIONS

GENERAL:

1. Rated lifting capacities in pounds as shown on lift charts pertain to this crane as originally manufactured and normally equipped. Modifications to the crane or use of optional equipment other than that specified can result in a reduction of capacity.
2. Construction equipment can be dangerous if improperly operated or maintained. Operation and maintenance of this crane must be in compliance with the information in the Operator's, Parts, and Safety Manuals supplied with this crane. If these manuals are missing, order replacements through the distributor.
3. The operator and other personnel associated with this crane shall read and fully understand the latest applicable American National Standards ASME B30.5 safety standards for cranes.
4. The rated lifting capacities are based on crane standing level on firm supporting surface.

SET UP:

1. The crane shall be leveled on a firm supporting surface. Depending on the nature of the supporting surface, it may be necessary to have structural supports under the outrigger pontoons or tires to spread the load to a larger bearing surface.
2. When making lifts on outriggers, all tires must be free of supporting surface. All outrigger beams must be extended to the same length; fully retracted, intermediate extended, or fully extended.
3. When operating on tires over side, do not exceed 75° maximum boom angle. Loss of backward stability will occur causing a backward tipping condition.
4. When making lifts on tires, they must be inflated to the recommended pressure. (See Operation note 20 and Tire Inflation.)
5. For required parts of line, see Wire Rope Capacity and Winch Performance.
6. Before setting up on intermediate outriggers, retracted outriggers, or tires, refer to Working Range Diagrams and rated lifting capacities to determine allowable crane configurations.

OPERATION:

1. Rated lifting capacities at rated radii shall not be exceeded. Do not tip the crane to determine allowable loads. For concrete bucket operation, weight of bucket and load shall not exceed 80% of rated lifting capacities. For clamshell bucket operation, weight of bucket and bucket contents is restricted to a maximum weight of 5,000 pounds or 80% of rated lifting capacity, whichever is less. For magnet operation, weight of magnet and load is restricted to a maximum weight of 5,000 pounds or 80% of rated lifting capacity, whichever is less. For clamshell and magnet operation, maximum boom length is restricted to 40 feet and the boom angle is restricted to a minimum of 35°. Lifts with any fly erected are prohibited for both clam and magnet operation.
2. Rated lifting capacities shown on fully extended outriggers do not exceed 85% of the tipping loads. Rated lifting capacities shown on intermediate extended or fully retracted outriggers are determined by the formula, rated load = (tipping load – 0.1 X load factor) / 1.25. Rated lifting capacities shown on tires do not exceed 75% of the tipping loads. Tipping loads are determined by SAE crane stability test code J-765.
3. Rated lifting capacities in the shaded areas are based on structural strength or hydraulic limitations and have been tested to meet minimum requirements of SAE J-1063 cantilevered boom crane structures—method of test. Rated lifting capacities in the non-shaded areas are based on stability ratings. Some capacities are limited by a maximum obtainable 78° boom angle.
4. Rated lifting capacities include the weight of hook ball/block, slings, bucket, magnet and auxiliary lifting devices. Their weights must be subtracted from the listed rated capacity to obtain the net load that can be lifted. Rated lifting capacities include the deduct for any fly stowed on the base of the boom. For deducts of any fly erected, but not used, see Capacity Deductions For Auxiliary Load Handling Equipment.
5. Rated lifting capacities are based on freely suspended loads. No attempt shall be made to move a load horizontally on the ground in any direction.
6. Rated lifting capacities are for lift crane service only.
7. Do not operate at radii or boom lengths (minimum or maximum) where capacities are not listed. At these positions, the crane can tip or cause boom failure.

8. The maximum loads that can be telescoped are not definable because of variation in loadings and crane maintenance, but it is permissible to attempt retraction and extension within the limits of the applicable load rating chart.
9. For main boom capacities when either boom length or radius or both are between values listed, proceed as follows:
 - a. For boom lengths not listed, use rating for next longer boom length or next shorter boom length, whichever is smaller.
 - b. For load radii not listed, use rating for next larger radius.
10. The user shall operate at reduced ratings to allow for adverse job conditions, such as: soft or uneven ground, out of level conditions, wind, side loads, pendulum action, jerking or sudden stopping of loads, hazardous conditions, experience of personnel, traveling with loads, electrical wires, etc. Side load on boom or fly is dangerous and shall be avoided.
11. Rated lifting capacities do not account for wind on suspended load or boom. Rated capacities and boom length shall be appropriately reduced as wind velocity approaches 20 mph.
12. When making lifts with auxiliary head machinery, the effective length of the boom increases by 2 feet.
13. Power sections of boom must be extended in accordance with boom mode "A" or "B". In boom mode "B" all power sections must be extended or retracted equally.
14. The least stable rated working area depends on the configuration of the crane set up.
15. Rated lifting capacities are based on correct reeving. Deduction must be made for excessive reeving. Any reeving over minimum required (see Wire Rope Capacity) is considered excessive and must be accounted for when making lifts. Use Working Range Diagram to estimate the extra feet of rope then deduct 1 lb. for each extra foot of wire rope before attempting to lift a load.
16. The loaded boom angle combined with the boom length give only an approximation of the operating radius. The boom angle, before loading, should be greater to account for deflection. For main boom capacities, the loaded boom angle is for reference only. For fly capacities, the load radius is for reference only.
17. For fly capacities with main boom length less than 91.25ft. and greater than 70 ft., the rated loads are determined by the boom angle using the 91.25ft. boom and fly chart. For angles not shown use the next lower boom angle to determine the rated capacity.
18. For fly capacities with main boom length less than 70ft. the rated loads are determined by the boom angle only using the 70ft. boom and fly chart. For angles not shown, use the next lower boom angle to determine the rated capacity.
19. The 29ft. boom length structural capacities are based on boom fully retracted. If the boom is not fully retracted, do not exceed capacities shown for the 40ft. boom length.
20. Rated lifting capacities on tires depend on tire capacity, condition of tires, and tire air pressure. On tire capacities require lifting from main boom head only on a smooth and level surface. Pick and carry operations are restricted to speed of 2.5 mph and creep. The boom must be centered over the front of the crane with two-position travel swing lock engaged and the load must be restrained from swinging. Lifts with any fly erected on tires are prohibited. For correct tire pressure, see Tire Inflation.

DEFINITIONS:

1. Load Radius: Horizontal distance from a projection of the axis of rotation to the supporting surface, before loading, to the center of the vertical hoist line or tackle with load applied.
2. Loaded Boom Angle: \angle° The angle between the boom base section and horizontal with freely suspended load at the rated radius.
3. Working Area: Area measured in a circular arc about the center line of rotation as shown on the Working Area Diagram.
4. Freely Suspended Load: Load hanging free with no direct external force applied except by the hoist line.
5. Side Load: Horizontal side force applied to the lifted load either on the ground or in the air.
6. No Load Stability Limit: The radius or boom angle beyond which it is not permitted to position the boom because the crane can overturn without any load on the hook.
7. Load Factor: Load applied at the boom tip which gives the same moment effect as the boom mass.
8. Creep: Crane movement limited to 200 ft. in a 30 min. period and not to exceed 1 mph maximum speed.

TIRE INFLATION

Tire Size	Operation	Tire Pressure (psi)
20.5 X 25-24 Ply Rating	2.5 mph	76
	Creep	95
	Stationary	95
20.5R25 1Star Rating	2.5 mph	83
	Creep	83
	Stationary	87

PONTOON LOADINGS

Carga Máxima en el Flotador	Maximum Pontoon Ground Bearing Pressure:
50,600 lb	208 psi

Boom Mode "A"

Only inner mid section telescopes.

Boom Length (Ft.)

29

40

49.75

Inner Mid Section 249" Stroke Base Section

Boom Mode "B"

Inner-mid, outer-mid and tip sections telescope simultaneously.

Boom Length (Ft.)

29

40

50

60

70

80

91.25

Tip Section Outer Mid Section Inner Mid Section Base Section
249" Stroke 249" Stroke 249" Stroke

WINCH PERFORMANCE

Wire Rope Layer	Winch Line Pulls		Drum Rope Capacity (Ft.)	
	Two Speed Winch		Layer	Total
	Low Speed Available Lbs.*	High Speed Available Lbs.		
1	11,948	6,125	77	77
2	10,807	5,540	84	161
3	9,866	5,058	93	254
4	9,075	4,652	101	355
5	8,401	4,307	109	464

* Maximum lifting capacity:
Type DB Rope = 11,770 Type RB Rope = 9,080

WIRE ROPE CAPACITY

Maximum Lifting Capacities Based On Wire Rope Strength			
Parts of Line	5/8"	5/8"	Notes
	Type DB	Type RB	
1	11,770	9,080	Capacities shown are in pounds and working loads must not exceed the ratings on the capacity charts in the Crane Rating Manual.
2	23,540	18,160	
3	35,310	27,240	
4	47,080	36,320	Study Operator's Manual for wire rope inspection procedures and single part of line application.
5	58,850	45,400	
6	70,620	54,480	
7	82,390	63,560	
LBCE		DESCRIPTION	
Type DB		6 X 26 (6 X 19 Class) – Warrington Seale – Extra Improved Plow Steel – Preformed – Right Regular Lay – I.W.R.C.	
Type RB		18 X 19 Rotation Resistant – Compacted Strand – High Strength, Preformed, Right Regular Lay	

HYDRAULIC CIRCUIT PRESSURE SETTINGS

Function	Pressure (psi)
Front And Rear Winch	3500
Outrigger	3000
Boom Hoist/ Telescope	3500
Swing	1600
Steering	2700
Pilot Control	500
Throttle	150

WORKING AREAS

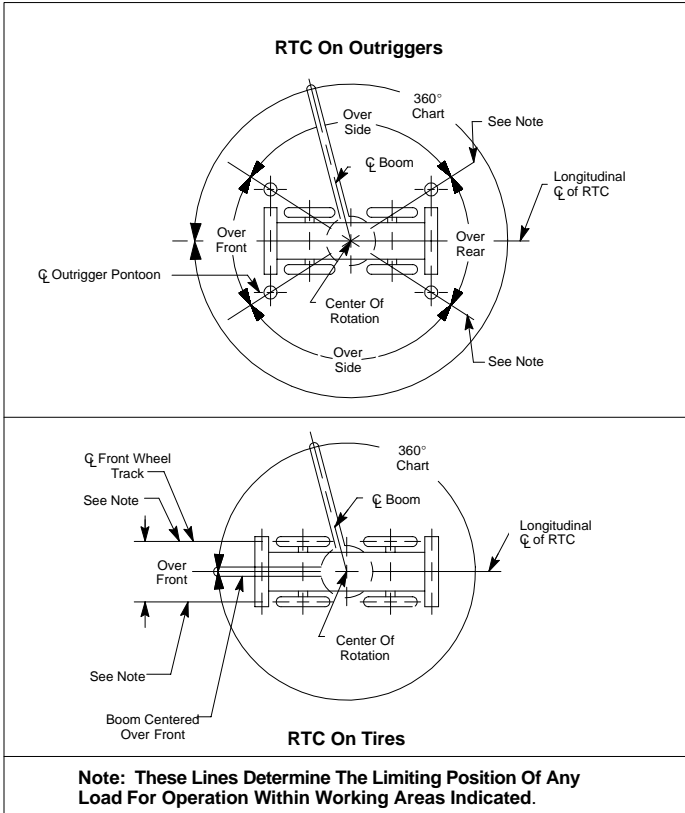

CAPACITY DEDUCTIONS FOR AUXILIARY LOAD HANDLING EQUIPMENT

Load Handling Equipment	Weight (lbs)
Auxiliary Head Attached	75
30 Ton Quick Reeve 3 Sheave Hook Block (See Hook Block For Actual Weight)	720
8.5 Ton Hook Ball (See Hook Ball For Actual Weight)	360

Lifting From Main Boom With:	
Fly Stowed On Boom Base (See Operation Note 4)	0
25 Ft. Fixed Fly Erected But Not Used	1300
27 Ft. Offset Fly Erected But Not Used	2300
44 Ft. Offset Fly Erected But Not Used	4300

Lifting From 27 Ft. Offset Fly With:	
17 Ft. Fly Tip Erected But Not Used	PROHIBITED
17 Ft. Fly Tip Stowed On 27 Ft. Offset Fly	PROHIBITED
Note: Capacity deductions are for Link-Belt supplied equipment only.	

WORKING RANGE DIAGRAM

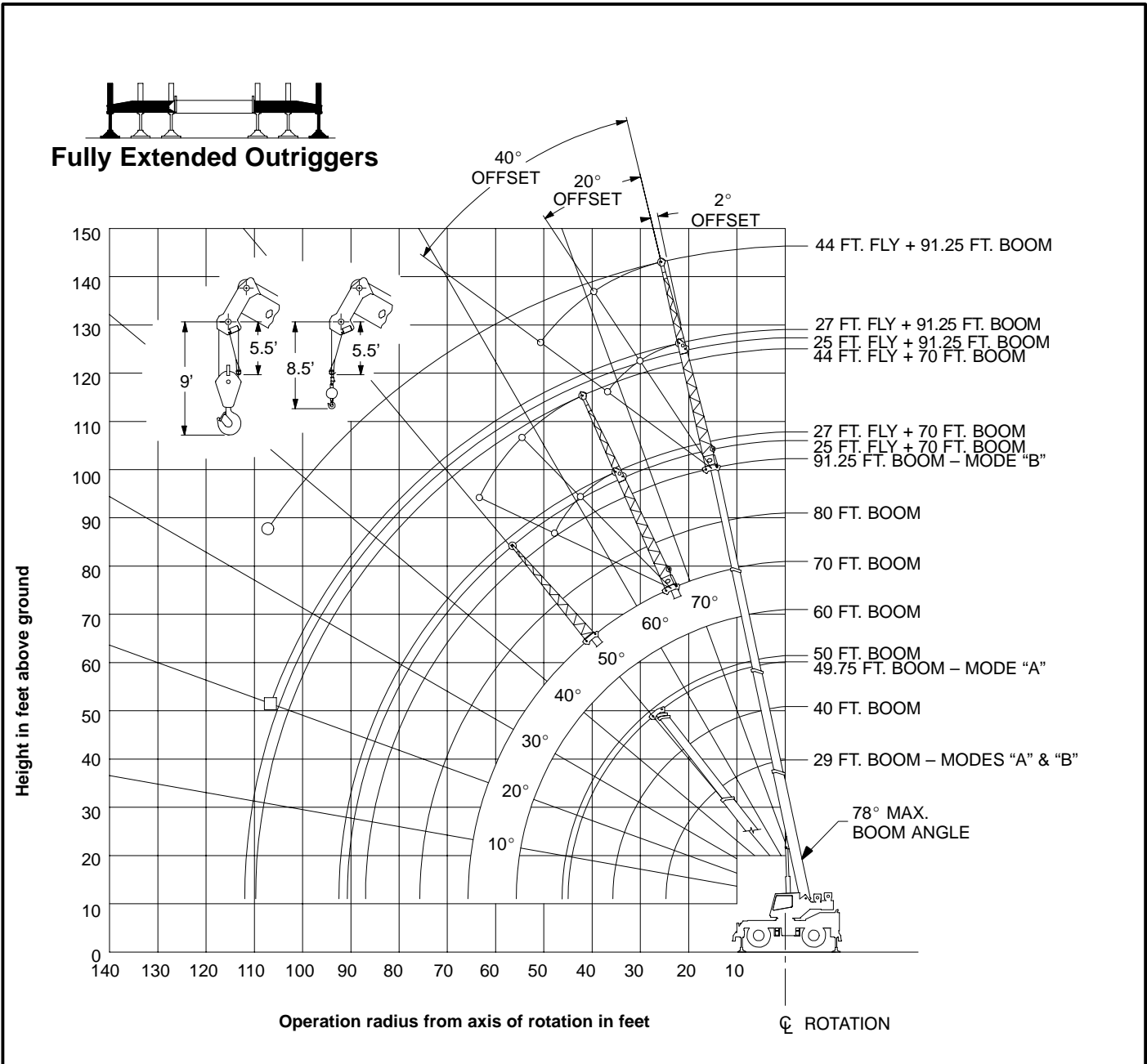

WARNING

Do Not Lower The Boom Below The Minimum Boom Angle For No Load Stability As Shown In The Lift Charts For The Boom Lengths Given. Loss Of Stability Will Occur Causing A Tipping Condition.

Rated Lifting Capacities In Pounds
Fully Extended Outriggers
See Set Up Note 2

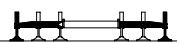
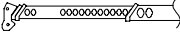
Load Radius (Ft.)	29 Ft.			40 Ft.			50 Ft.		
	∠ °	360°	Over Front	∠ °	360°	Over Front	∠ °	360°	Over Front
10	64.5	60,000	60,000	72.5	50,100	50,100	76.0	31,300	31,300
12	60.0	52,300	52,300	69.5	47,600	47,600	74.0	31,300	31,300
15	52.5	43,000	43,000	64.5	40,600	40,600	70.5	31,300	31,300
20	37.0	31,200	31,200	56.0	30,900	30,900	64.0	27,600	27,600
25				46.0	23,300	23,300	57.0	22,900	22,900
30				34.5	18,300	18,300	49.5	18,100	18,100
35				14.5	14,600	14,600	41.0	14,500	14,500
40							30.5	11,200	11,200
45							11.5	8,700	8,800
Min.Bm Ang./Cap.	0 (24.8)	22,400	22,400	0 (35.8)	14,100	14,100	0 (45.5)	8,500	8,500

Note: Refer To Page 5 For "Capacity Deductions For Load Handling Equipment."
∠ ° Loaded Boom Angle In Degrees. () Reference Radius For Minimum Boom Angle Capacities (Shown in Parenthesis) Are In Feet. *This Capacity Based On Maximum Obtainable Boom Angle.

Rated Lifting Capacities In Pounds
Fully Extended Outriggers
See Set Up Note 2



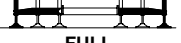
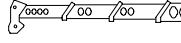

Load Radius (Ft.)	29 Ft.			40 Ft.			50 Ft.		
	∠ °	360°	Over Front	∠ °	360°	Over Front	∠ °	360°	Over Front
10	64.5	60,000	60,000	72.0	25,000	25,000	76.0	25,000	25,000
12	60.0	52,300	52,300	69.0	25,000	25,000	74.0	25,000	25,000
15	52.5	43,000	43,000	64.5	25,000	25,000	70.5	25,000	25,000
20	37.0	31,200	31,200	56.0	25,000	25,000	64.0	25,000	25,000
25				46.0	24,300	24,300	57.0	24,600	24,600
30				34.0	19,200	19,200	49.5	19,500	19,500
35				14.5	15,500	15,500	41.0	15,900	15,900
40							30.5	12,700	12,700
45							13.0	10,200	10,200
Min.Bm Ang./Cap.	0 (24.8)	22,400	22,400	0 (35.8)	13,500	13,500	0 (45.8)	9,500	9,500

Load Radius (Ft.)	60 Ft.			70 Ft.		
	∠ °	360°	Over Front	∠ °	360°	Over Front
12	76.5	25,000	25,000			
15	74.5	25,000	25,000	77.0	25,000	25,000
20	69.0	25,000	25,000	73.0	25,000	25,000
25	64.0	24,200	24,200	68.5	22,700	22,700
30	58.0	19,700	19,700	64.0	19,100	19,100
35	52.0	16,100	16,100	59.0	16,200	16,200
40	45.5	12,900	12,900	54.0	13,000	13,000
45	37.5	10,400	10,500	48.5	10,500	10,600
50	28.0	8,600	8,600	42.0	8,700	8,700
55	12.0	7,100	7,100	35.0	7,200	7,300
60				26.0	6,100	6,100
65				11.5	5,100	5,100
Min.Bm Ang./Cap.	0 (55.8)	6,900	6,900	0 (65.8)	4,900	5,000

Load Radius (Ft.)	80 Ft.			91.25 Ft.		
	∠ °	360°	Over Front	∠ °	360°	Over Front
20	76.0	25,000	25,000	78.0*	19,000	19,000
25	72.0	21,400	21,400	75.0	19,000	19,000
30	68.5	18,100	18,100	72.0	16,800	16,800
35	64.5	15,500	15,500	68.5	14,700	14,700
40	60.0	13,000	13,100	65.0	12,800	12,800
45	55.5	10,600	10,700	61.0	10,700	10,700
50	50.5	8,800	8,800	57.0	8,800	8,900
55	45.5	7,300	7,400	53.0	7,400	7,400
60	39.5	6,100	6,200	48.5	6,200	6,300
65	33.0	5,200	5,200	44.0	5,200	5,300
70	25.0	4,400	4,400	39.0	4,400	4,500
75	11.0	3,700	3,700	33.0	3,800	3,800
80				26.0	3,200	3,300
85				15.0	2,700	2,700
Min.Bm Ang./Cap.	0 (75.8)	3,600	3,600	0 (87.0)	2,500	2,500

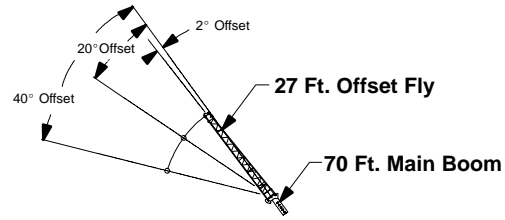
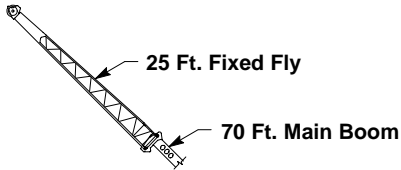
Note: Refer To Page 5 For "Capacity Deductions For Load Handling Equipment."
∠ ° Loaded Boom Angle In Degrees. () Reference Radius For Minimum Boom Angle Capacities (Shown in Parenthesis) Are In Feet. *This Capacity Based On Maximum Obtainable Boom Angle.

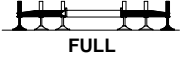

Rated Lifting Capacities In Pounds Fully Extended Outriggers See Set Up Note 2			
Load Radius (Ft.)	\angle °	360°	
20	78.0*	15,200	
25	75.0	13,500	
30	72.0	12,200	
35	68.5	10,600	
40	65.5	9,800	
45	62.0	9,100	
50	58.5	8,200	
55	55.0	7,500	
60	51.0	7,000	
65	46.5	6,100	
70	42.0	5,300	
75	36.5	4,600	
80	30.5	4,000	
85	23.0	3,500	
90	10.5	3,000	
Min.Bm. Ang./Cap.	0	2,900	

Note: Refer To Page 5 For "Capacity Deductions For Auxiliary Load Handling Equipment". \angle Loaded Boom Angle In Degrees. * This Capacity Based On Maximum Obtainable Boom Angle.

Rated Lifting Capacities In Pounds Fully Extended Outriggers See Set Up Note 2							
Load Radius (Ft.)	2° Offset		20° Offset		40° Offset		
	\angle °	360°	\angle °	360°	\angle °	360°	
25	75.5	13,000					
30	72.5	11,000	77.0	7,700			
35	69.0	10,100	73.5	7,100	78.0*	5,300	
40	66.0	9,300	70.5	6,500	74.5	5,000	
45	62.5	8,400	67.0	6,100	71.0	4,800	
50	59.5	7,600	63.5	5,700	67.5	4,600	
55	55.5	6,900	60.0	5,400	63.5	4,500	
60	52.0	6,400	56.5	5,100	59.5	4,400	
65	48.0	5,800	52.0	4,800	55.5	4,200	
70	43.5	5,000	48.0	4,600	50.5	4,200	
75	38.5	4,300	43.0	4,400	45.5	4,100	
80	32.5	3,700	37.0	3,900			
85	26.0	3,200	30.0	3,300			
90	16.5	2,800					
Min. Bm. Ang./Cap.	0	2,400	0	2,500	0	2,700	

Note: Refer To Page 5 For "Capacity Deductions For Auxiliary Load Handling Equipment". \angle Loaded Boom Angle In Degrees. * This Capacity Based On Maximum Obtainable Boom Angle.

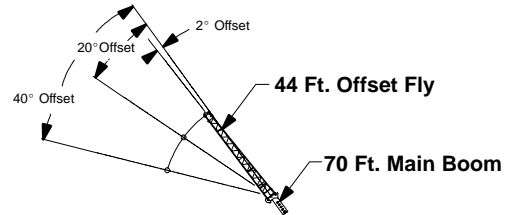
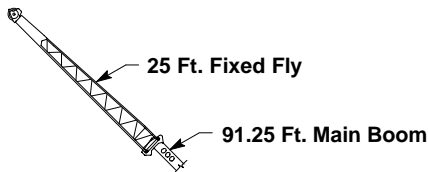

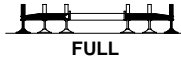
Rated Lifting Capacities In Pounds Fully Extended Outriggers See Set Up Note 2			
Load Radius (Ft.)	\angle °	360°	
30	76.5	10,200	
35	74.5	10,200	
40	72.0	9,800	
45	69.5	9,200	
50	67.0	8,400	
55	64.0	7,700	
60	61.0	6,900	
65	58.0	5,900	
70	54.5	5,100	
75	51.0	4,400	
80	47.5	3,800	
85	43.5	3,300	
90	39.5	2,900	
95	35.0	2,500	
100	29.5	2,100	
105	23.5	1,800	
110	14.0	1,500	
Min.Bm. Ang./Cap.	0	1,400	

Note: Refer To Page 5 For "Capacity Deductions For Auxiliary Load Handling Equipment". \angle Loaded Boom Angle In Degrees.

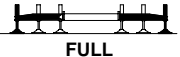
Rated Lifting Capacities In Pounds Fully Extended Outriggers See Set Up Note 2							
Load Radius (Ft.)	2° Offset		20° Offset		40° Offset		
	\angle °	360°	\angle °	360°	\angle °	360°	
30	76.0	7,400					
35	73.5	6,600					
40	70.5	5,800	77.0	4,000			
45	68.0	5,300	74.5	3,700			
50	65.0	4,800	71.5	3,500	78.0*	2,700	
55	62.5	4,300	69.0	3,200	75.0	2,500	
60	59.5	4,000	66.0	3,000	72.0	2,400	
65	56.5	3,700	63.0	2,900	68.5	2,300	
70	53.5	3,400	59.5	2,700	65.5	2,300	
75	50.0	3,100	56.5	2,600	61.5	2,200	
80	46.5	2,900	52.5	2,400	57.5	2,100	
85	42.5	2,700	49.0	2,300	53.5	2,100	
90	38.5	2,600	44.5	2,200	48.5	2,100	
95	34.0	2,400	40.0	2,200	43.0	2,100	
100	28.5	2,300	34.0	2,100			
105	21.0	2,000	26.0	2,100			
Min.Bm. Ang./Cap.	0	1,500	0	1,600	0	1,800	

Note: Refer To Page 5 For "Capacity Deductions For Auxiliary Load Handling Equipment". \angle Loaded Boom Angle In Degrees. * This Capacity Based On Maximum Obtainable Boom Angle.

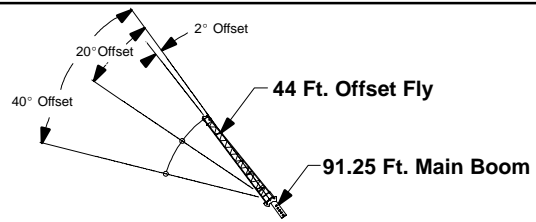
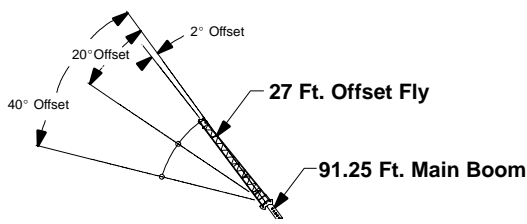

Rated Lifting Capacities In Pounds Fully Extended Outriggers See Set Up Note 2						
Load Radius (Ft.)	2° Offset		20° Offset		40° Offset	
	∠°	360°	∠°	360°	∠°	360°
	30	77.0	9,900			
35	75.0	9,700	78.0*	7,200		
40	72.5	9,300	76.0	6,800		
45	70.0	8,600	73.5	6,400	76.5	5,000
50	67.5	7,800	71.0	6,100	74.0	4,800
55	64.5	7,200	68.0	5,800	71.0	4,600
60	62.0	6,600	65.5	5,500	68.5	4,500
65	58.5	5,600	62.5	5,200	65.5	4,400
70	55.5	4,800	59.5	5,000	62.5	4,300
75	52.0	4,100	56.5	4,400	59.0	4,200
80	48.5	3,500	52.5	3,800	55.5	4,000
85	45.0	3,000	49.0	3,200	51.5	3,400
90	41.0	2,600	45.0	2,800	47.0	2,900
95	36.5	2,200	40.5	2,300	42.0	2,400
100	31.5	1,800	35.5	2,000		
105	26.0	1,500	29.0	1,600		
110			21.0	1,300		

WARNING
Do Not Lower 27 Ft. Offset Fly In Working Position Below 20° Main Boom Angle Unless Main Boom Length Is 87 Ft. Or Less, Since Loss Of Stability Will Occur Causing A Tipping Condition.

Rated Lifting Capacities In Pounds Fully Extended Outriggers See Set Up Note 2						
Load Radius (Ft.)	2° Offset		20° Offset		40° Offset	
	∠°	360°	∠°	360°	∠°	360°
	35	77.5	6,500			
40	75.5	6,000				
45	73.5	5,500				
50	71.0	5,100	76.5	3,600		
55	69.0	4,700	74.0	3,400		
60	66.5	4,400	72.0	3,200	77.0	2,500
65	64.5	4,100	69.5	3,100	74.5	2,400
70	62.0	3,800	67.0	2,900	72.0	2,300
75	59.5	3,600	64.5	2,800	69.5	2,300
80	57.0	3,400	62.0	2,700	66.5	2,200
85	54.5	3,200	59.5	2,500	64.0	2,200
90	51.5	2,800	56.5	2,400	61.0	2,100
95	48.0	2,400	54.0	2,400	57.5	2,100
100	45.0	2,000	50.5	2,300	54.5	2,100
105	41.5	1,700	47.0	2,000	50.5	2,100
110	37.5	1,400	43.0	1,700	46.0	1,800
115			38.5	1,400	40.5	1,500

WARNING
Do Not Lower 44 Ft. Offset Fly In Working Position Below 34.5° Main Boom Angle Unless Main Boom Length Is 80 Ft. Or Less, Since Loss Of Stability Will Occur Causing A Tipping Condition.

Note: Refer To Page 5 For "Capacity Deductions For Auxiliary Load Handling Equipment". ∠° Loaded Boom Angle In Degrees. * This Capacity Based On Maximum Obtainable Boom Angle.

Note: Refer To Page 5 For "Capacity Deductions For Auxiliary Load Handling Equipment". ∠° Loaded Boom Angle In Degrees.

WORKING RANGE DIAGRAM

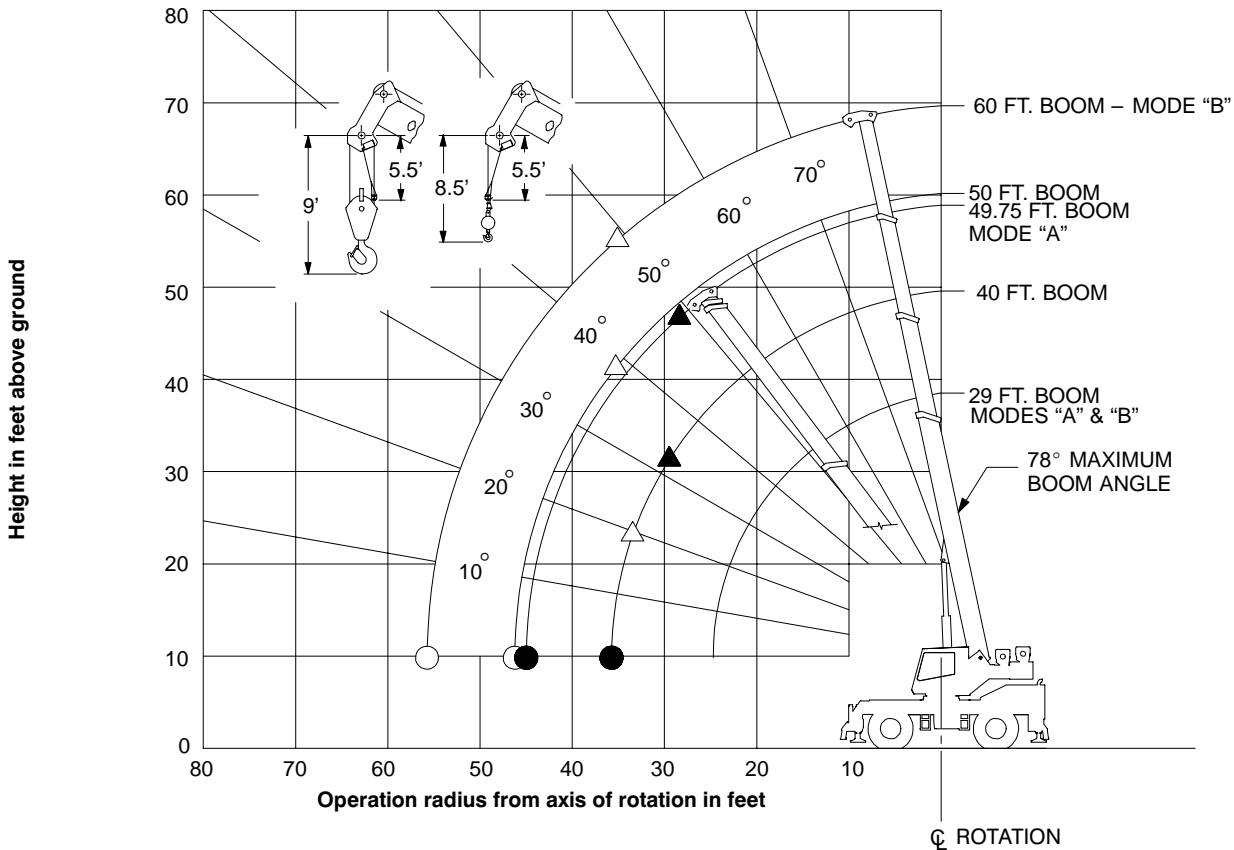

Crane Configurations Prohibited:
 Boom Lengths Greater than 60 FT.
 25 Ft. Fixed Fly
 27 Ft. Offset Fly
 44 Ft. Offset Fly

- ▲ Denotes Main Boom 360° – Boom Mode “A”
- △ Denotes Main Boom 360° – Boom Mode “B”
- Denotes Main Boom Between Tire Tracks Or Centered Over Front – Boom Mode “A”
- Denotes Main Boom Between Tire Tracks Or Centered Over Front – Boom Mode “B”

Note: Boom geometry shown is for unloaded condition and crane standing level on firm supporting surface. Boom deflection, subsequent radius and boom angle change must be accounted for when applying load to hook.

WARNING

Do Not Lower The Boom Below The Minimum Boom Angle For No Load Stability As Shown In The Lift Charts For The Boom Lengths Given. Loss Of Stability Will Occur Causing A Tipping Condition.

On Tire Capacities In Pounds
Tire Pressure: See Page 5
Stationary Capacities
Over Front Between Tire Tracks
See Operation Note 20

ON TIRES

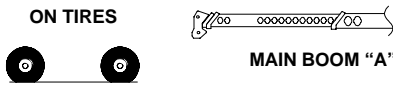

MAIN BOOM "A"

Load Radius (Ft.)	29 Ft.		40 Ft.		49.75 Ft.	
	∠ °	Load	∠ °	Load	∠ °	Load
10	64.5	32,800				
12	59.5	28,900	69.0	28,600		
15	52.0	24,300	64.0	24,000		
20	37.0	17,400	55.5	17,100	63.5	16,800
25			46.0	11,400	56.5	11,200
30			34.0	8,000	49.0	7,900
35			14.0	5,700	40.5	5,600
40					30.0	4,000
45					11.0	2,800
Min.Bm. Ang./Cap.	0 (24.8)	11,700	0 (35.8)	5,400	0 (45.5)	2,700

Note: Refer To Page 5 For "Capacity Deductions For Auxiliary Load Handling Equipment". ∠ Loaded Boom Angle In Degrees. () Reference Radius For Minimum Boom Angle Capacities (Shown In Parenthesis) Are In Feet.

On Tire Capacities In Pounds
Tire Pressure: See Page 5
Pick & Carry Capacities
(1 MPH) Boom Centered Over Front
See Operation Note 20

ON TIRES

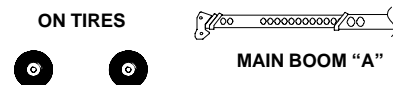

MAIN BOOM "A"

Load Radius (Ft.)	29 Ft.			40 Ft.			49.75 Ft.		
	∠ °	Creep	2.5 mph	∠ °	Creep	2.5 mph	∠ °	Creep	2.5 mph
10	64.5	31,900	22,200						
12	59.5	27,600	19,000	69.0	27,300	18,700			
15	52.0	22,700	15,300	64.0	22,500	15,000			
20	37.0	17,000	11,000	55.5	16,800	10,800	63.5	16,700	10,700
25				46.0	11,400	7,900	56.5	11,200	7,800
30				34.0	8,000	5,800	49.0	7,900	5,700
35				14.0	5,700	4,200	40.5	5,600	4,200
40							30.0	4,000	2,900
45							11.0	2,800	1,900
Min.Bm. Ang./Cap.	0 (24.8)	11,700	8,100	0 (35.8)	5,400	4,000	0 (45.5)	2,700	1,800

Note: Refer To Page 5 For "Capacity Deductions For Auxiliary Load Handling Equipment". ∠ Loaded Boom Angle In Degrees. () Reference Radius For Minimum Boom Angle Capacities (Shown In Parenthesis) Are In Feet.

On Tire Capacities In Pounds
Tire Pressure: See Page 5
Stationary Capacities
Over Front Between Tire Tracks
See Operation Note 20

ON TIRES

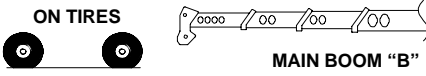

MAIN BOOM "B"

Load Radius (Ft.)	29 Ft.		40 Ft.	
	∠ °	Load	∠ °	Load
10	64.5	32,800	72.0	25,000
12	59.5	28,900	69.0	25,000
15	52.0	24,300	64.0	24,800
20	37.0	17,400	55.5	18,100
25			46.0	12,300
30			34.0	8,800
35			14.0	6,500
Min.Bm. Ang./Cap.	0 (24.8)	11,700	0 (35.8)	6,200
Load Radius (Ft.)	50 Ft.		60 Ft.	
	∠ °	Load	∠ °	Load
20	63.5	18,300		
25	56.5	12,600	63.5	12,700
30	49.0	9,200	57.5	9,300
35	40.5	6,900	51.5	7,100
40	30.0	5,200	45.0	5,400
45	12.5	4,000	37.0	4,200
50			27.5	3,200
55			11.5	2,500
Min.Bm. Ang./Cap.	0 (45.8)	3,800	0 (55.8)	2,300

Note: Refer To Page 5 For "Capacity Deductions For Auxiliary Load Handling Equipment". ∠ Loaded Boom Angle In Degrees. () Reference Radius For Minimum Boom Angle Capacities (Shown In Parenthesis) Are In Feet.

On Tire Capacities In Pounds
Tire Pressure: See Page 5
Pick & Carry Capacities
(1 MPH) Boom Centered Over Front
See Operation Note 20

ON TIRES

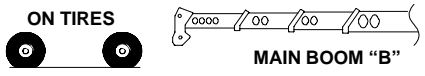

MAIN BOOM "B"

Load Radius (Ft.)	29 Ft.			40 Ft.		
	∠ °	Creep	2.5 mph	∠ °	Creep	2.5 mph
10	64.5	31,900	22,200	72.0	25,000	22,500
12	59.5	27,600	19,000	69.0	25,000	19,400
15	52.0	22,700	15,300	64.0	23,200	15,800
20	37.0	17,000	11,000	55.5	17,500	11,600
25				46.0	12,300	8,700
30				34.0	8,800	6,600
35				14.0	6,500	5,000
Min.Bm. Ang./Cap.	0 (24.8)	11,700	8,100	0 (35.8)	6,200	4,800
Load Radius (Ft.)	50 Ft.			60 Ft.		
	∠ °	Creep	2.5 mph	∠ °	Creep	2.5 mph
20	63.5	17,800	11,800			
25	56.5	12,600	9,000	63.5	12,700	9,100
30	49.0	9,200	6,900	57.5	9,300	7,100
35	40.5	6,900	5,300	51.5	7,100	5,500
40	30.0	5,200	4,100	45.0	5,400	4,300
45	12.5	4,000	3,100	37.0	4,200	3,300
50				27.5	3,200	2,500
55				11.5	2,500	1,800
Min.Bm. Ang./Cap.	0 (45.8)	3,800	2,900	0 (55.8)	2,300	1,700

Note: Refer To Page 7 For "Capacity Deductions For Auxiliary Load Handling Equipment". ∠ Loaded Boom Angle In Degrees. * This Capacity Based On Maximum Obtainable Boom Angle.

On Tire Capacities In Pounds
Tire Pressure: See Page 5
Stationary Capacities – 360 Degree
See Operation Note 20



360°
ON TIRES **MAIN BOOM "A"**

Load Radius (Ft.)	29 Ft.		40 Ft.		49.75 Ft.	
	∠ °	Load	∠ °	Load	∠ °	Load
10	64.5	24,000	69.0	17,200	63.0	6,700
12	59.5	17,700		11,700		
15	52.0	12,000	55.5	6,800	56.5	4,000
20	37.0	7,000	46.0	4,100	49.0	2,200
25			34.0	2,300		
30						
Min.Bm Ang./Cap.	0 (24.8)	4,200	26.5 (32.3)	—	45.5 (31.9)	—

Note: Refer To Page 5 For "Capacity Deductions For Auxiliary Load Handling Equipment". ∠ Loaded Boom Angle In Degrees. () Reference Radius For Minimum Boom Angle Capacities (Shown In Parenthesis) Are In Feet.

On Tire Capacities In Pounds
Tire Pressure: See Page 5
Stationary Capacities – 360 Degree
See Operation Note 20

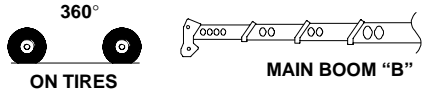

360°
ON TIRES **MAIN BOOM "B"**

Load Radius (Ft.)	29 Ft.		40 Ft.	
	∠ °	Load	∠ °	Load
10	64.0	24,000	72.0	24,400
12	59.5	17,700	69.0	18,200
15	52.0	12,000	64.0	12,700
20	37.0	7,000	55.5	7,700
25			45.5	4,900
30			34.0	3,100
35			14.0	1,800
Min.Bm Ang./Cap.	0 (24.8)	4,200	0 (35.8)	1,700
Load Radius (Ft.)	50 Ft.		60 Ft.	
	∠ °	Load	∠ °	Load
20	63.5	7,900	63.0	5,300
25	56.5	5,200		3,600
30	49.0	3,400	51.0	2,400
35	40.5	2,200		
Min.Bm Ang./Cap.	34 (38.2)	—	45.5 (39.4)	—

Note: Refer To Page 5 For "Capacity Deductions For Auxiliary Load Handling Equipment". ∠ Loaded Boom Angle In Degrees. () Reference Radius For Minimum Boom Angle Capacities (Shown In Parenthesis) Are In Feet.