

MAGNI
TELESCOPIC HANDLERS



RTH

Courtesy of Crane.Market

MAGNI TH, OUR EXPERTISE AND AFFIDABILITY FOR YOUR NEEDS

The RTH range we developed and designed is the result of years of expertise and research. This range must in fact reflect and satisfy all the needs of our customer and their request for trustworthy and high performances machines.

Our machines are built to grant the best standards in terms of quality, safety and reliability. Only the best component are fitted in our machines and only the best materials are used to achieve the best performances. We also provide a very versatile machine, that can be equipped following the customer's needs.

This versatility is granted by:

- a large range of interchangeable attachments, that has been specifically developed for these machines and that allows a large flexibility in terms of usage;
- our software, together with the electric CAN BUS system, allows to customize hydraulic speeds and the restrictions of machine's movements according to the tasks the machine has to do.
- three types of steering
- the new interface which is user friendly and very intuitive.

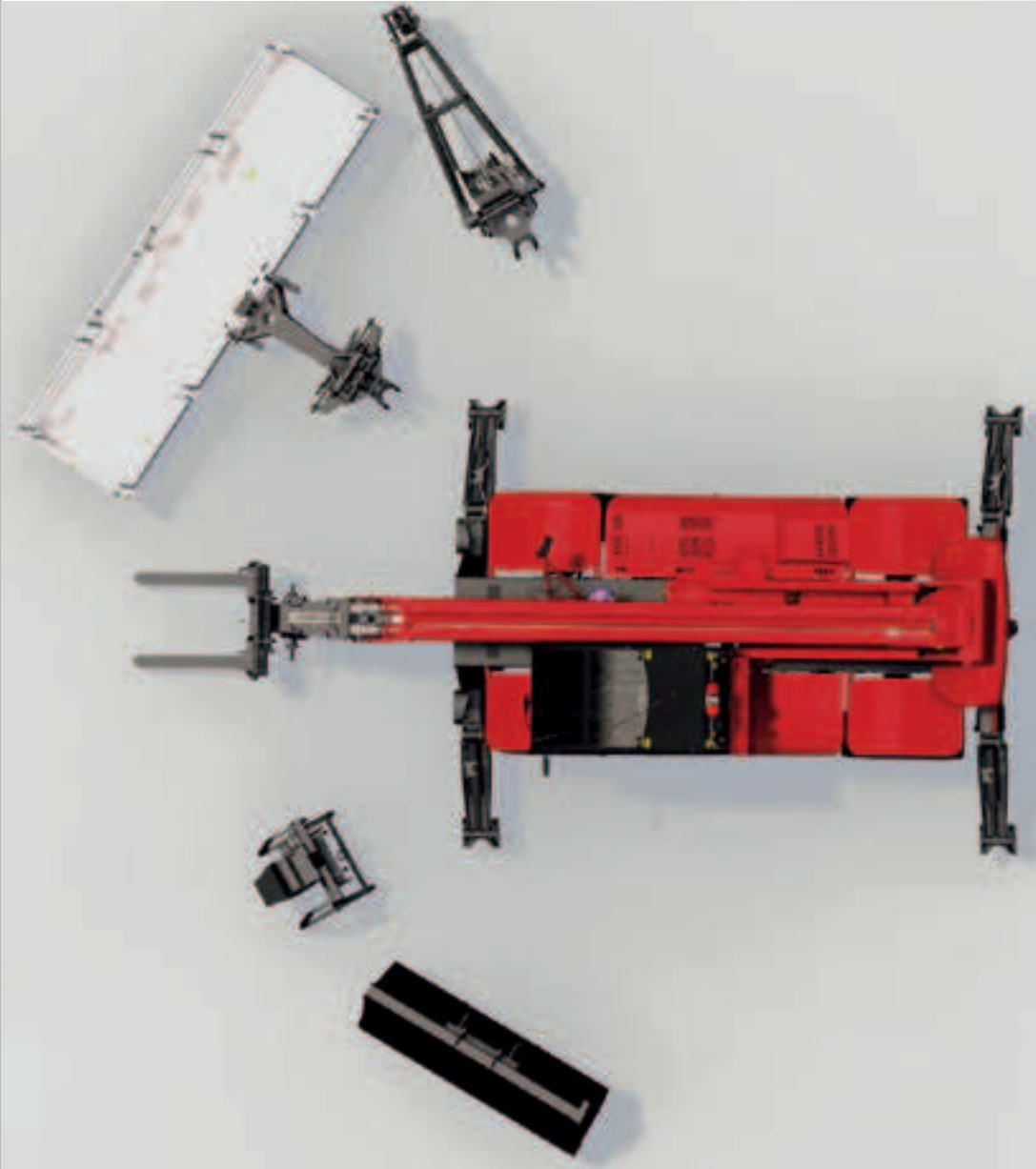

SMART

SMART S

SCISSORS



RTH 5.18 Smart RTH 5.21 Smart RTH 5.23 Smart RTH 5.25 Smart RTH 5.21 Smart S RTH 5.23 Smart S RTH 5.25 Smart S RTH 6.24 S RTH 5.26 S RTH 5.30 S RTH 5.35 S RTH 5.39 S



MAGNI REGISTERED DESIGN CAB

The fully **enclosed and airtight** cab, fully **pressurized** and with **100% inlet air filtration** allows Magni machines to work in polluted environments without any risk for the operator. Hot and cold **air conditioning** is part of the standard equipment for all models granting the operator to work with closed door and to exploit at its maximum the airtight cab.

MAGNI CONTROL PANEL

A **user friendly touch screen** display is used to manage the whole machine, is very intuitive and interfaces with the operator with more than **170 written faults messages** in **8 different languages**. The screen is IP67 and can also be managed through an automotive style joystick. Stabilizers and levelling can be managed also with dedicated buttons.



INTEGRATED DIAGNOSTIC

The **simple and short trouble shooting time** on electrical circuit and electronically managed components consent a shorter time stop and a cost reduction in case of electric failures. When a breakdown is detected the system automatically cuts any movement and displays an alarm code which identifies the failure. This system is very **reliable** and helps the technician to find problems on electrical circuit showing input and output of each component.

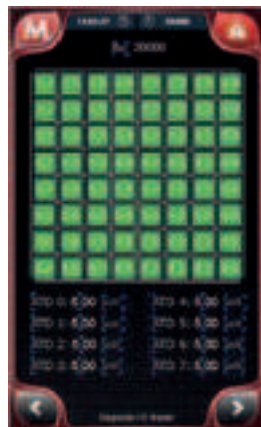

REMOTE CONTROLS

Magni machines can be quipped with two types of remote control that both allows to perform all the hydraulic movements of the machine: if cabled with the aerial platform, or wireless with other types of attachments. The top version of this remote control allows to manage also stabilizers and machine transmission up to 5 km\h from a distance of 100 m. The remote control joysticks are electro-proportional as the one in the cabin: i.e. they exactly resemble the same precision in movements.



PLATFORM AND REMOTE CONTROL

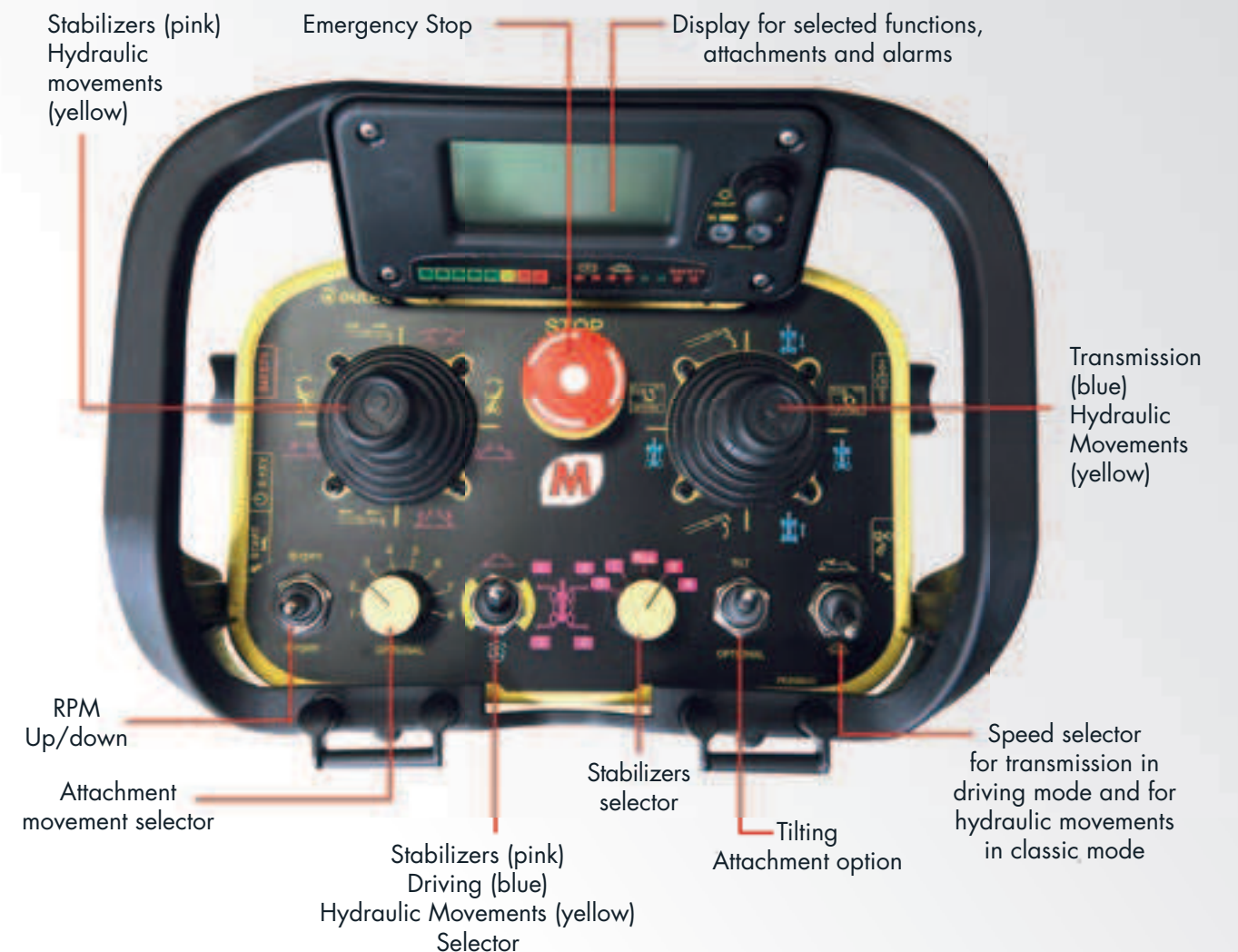

SPECIAL PLATFORM AND REMOTE CONTROL

FULL VISIBILITY CAB

The innovative design of Magni cab has been developed to grant the comfort and safety of the operator and to make the maneuvering of the machine safe and simple. The cabin has full visibility thanks to a large windshield, from the bottom to the top, that allows the operator to look at the load even when it is suspended on his head and also with the boom completely lowered facilitating the loading of materials on ground with forks. The movable steering column allows the operator to get in and out easily and achieve an excellent driving position.

MCTS

The Magni Combi Touch System is a brand new concept for machine management; it is easy to use for both expert and new operators, thanks to the **icon-style graphic** that makes it very **intuitive**. It is possible to switch from one page to the other with arrows on the screen or with buttons around the joystick. The system is divided in **5 main pages** each one dedicate to different functions of the machine.

DRIVING PAGE

All data concerning **transmission** and its components are shown in the upper part as a classic dashboard, whereas in the lower part is possible to select **type of steering**, helped by two tyres alignment sensors. Here is also possible to set high or low range speed.



CUSTOMIZATION PAGE

Here limits for turret rotation on 360° of the machine and also for the working height are displayed and could be useful if there is any obstacle in the working space, if working inside a low ceiling building or if a repetitive working cycle has to be done. In addition can also be **adjusted hydraulic speeds** of lifting\lowering and extension\retraction of the boom; of turret rotation, of forks tilting and of attachment functions in order to regulate the speed to execute **dangerous**, very **precise** or **repetitive maneuvers**.



STABILIZATION PAGE

Magni TH models have an **interactive stability area** thanks to the fact that inside each outrigger is placed a potentiometer that measure the length (from 0% up to 100%) of the stabilizer's extension and basing on those data the software gives to the operator a **progressive load chart** which increases with the increase of the outrigger length, so the machine will always perform the best load chart for the stabilization base. Moreover Magni models are equipped with an electronic bubble which allows to have **auto levelling** on outriggers.

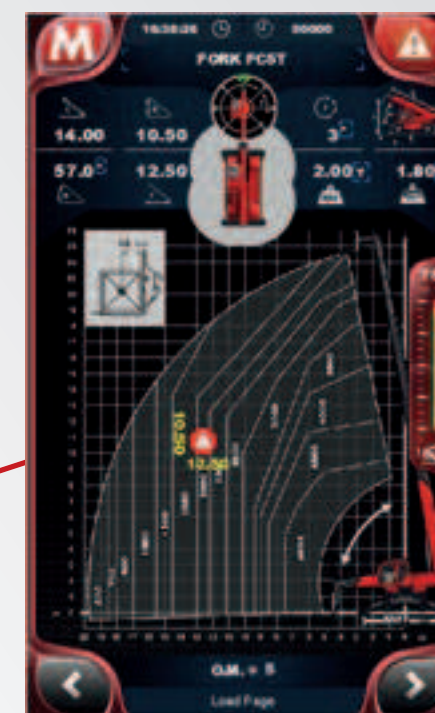

LOAD CHART PAGE

Magni Telescopic Handlers use Load Moment Indicators meeting crane regulations, Magni's touch screen can show a dynamic load chart on the screen which allows to see the load center moving according to the real movements the operator is doing.



COMMAND PAGE

The upper part is for managing cabin **basic commands** (as temperature and ventilation), the middle part is for all the machine lights and the lowest one is dedicated to various available options and to switch from the cabin to remote control.





18-21-23-24-25-26-30-35-39
Max. lifting height

5 t - 6 t
Lifting capacity

ROUGH TERRAIN



LEVELLING SYSTEM

A levelling system is equipped on all the models of the range to adapt to any **side slope (+/- 10°)**.



ROUGH TERRAIN

The powerful hydrostatic transmission, supply each wheel all the requested power to face the most bumpy terrains and the hardest slopes. Equipped with a 4 wheel drive, 2 speeds forward\reverse and a rear tilting axle RTHs grant perfect stability and a great grip to the ground. In addition the impressive ground clearance allows to overcome any obstacle.

GROUND CLEARANCE ON TYRES

5.18 Smart - 5.21Smart - 5.23 Smart - 5.25 Smart 329 mm
5.21 Smart S - 5.23 Smart S - 5.25 Smart S - 6.24S - 5.26S - 5.30S - 5.35S - 5.39S 320 mm

Max. Reach over
25 m



Both pivoting and scissors outriggers are optimal to work in the most confined jobsites; the first one thanks to the very **compact** stabilization area and the latter thanks to their **flexibility**, they can in fact adapt to the operator's need or the condition of working space.



Each model can have free road circulation and 3 different types of steering are available for all them:

- **Round steering:** to improve steering radius and move in tight spaces;
- **Front steering:** for the road circulation
- **Crab steering:** which offer the possibility of a diagonal narrowing to the target during operation

3 TYPES OF STEERING

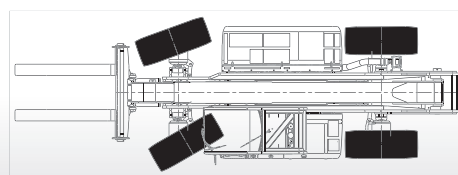

Front steering

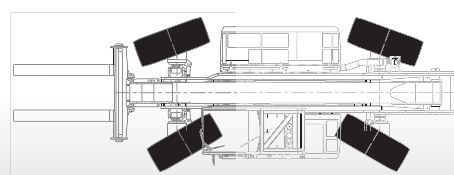

Round steering

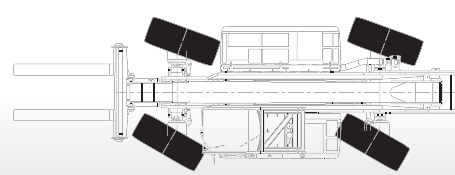

Crab steering

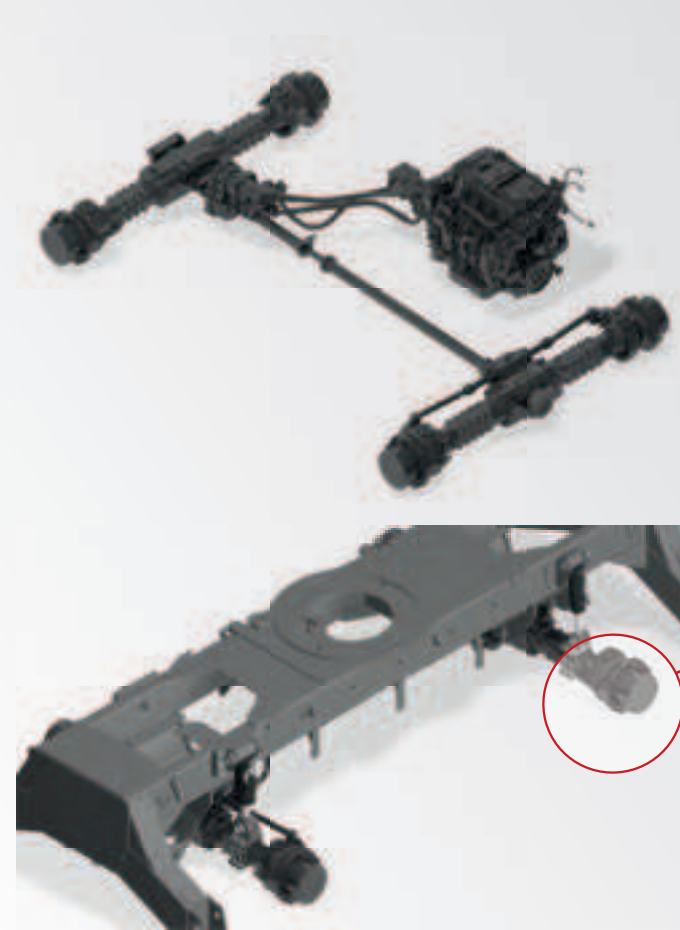

Epicyclic reduction gear and oil immersed brakes on 4 wheels.

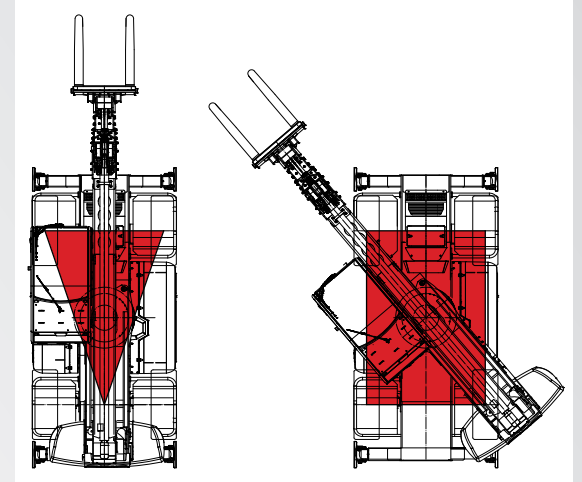

The equipped axles specific for this type of machine, with epicyclic reduction and oil-immersed multi-disc brakes, have steering cylinder on the upper part in order to protect them from accidental collision. The rear axle remain tilting to ensure the best rough terrain performance but the machine is provided with an **automatic differential locking** after +/- 5° turret rotation to grant a better stability.



ENGINE

All engines equipped on Magni models comply with the 97/68/EC directive concerning engine emissions standards. The electronic managing of the transmission ensures the perfect adaptation to engine torque curves in order to optimize the use of components and the engine assumption with a consequent **reduction of 10-15% of fuel consumption** and longer life of components.



The load sensing system (**350 bar** effective working pressure) is composed by one l/s high pressure pump; (for hydraulic movement) placed in line; two electro-proportional joysticks and a SIL 2 safety main valve complying to the EN 13489 concerning the safety of electronic controls. Face seals fittings, thermoplastic hoses and pipes grant a **perfect tightness** on the long term; this is further ensured by the circuit itself, mainly constituted by pipes rather than hoses.

The electronic management of hydraulics allows the system to set the best rpm rate for the hydraulic effort required with a consequent reduction of fuel consumption. Our software also manages the **flow sharing** system so once one movement stops, the other one increases gradually, granting safer and more precise hydraulic movements (up to 3/4 at the same time).

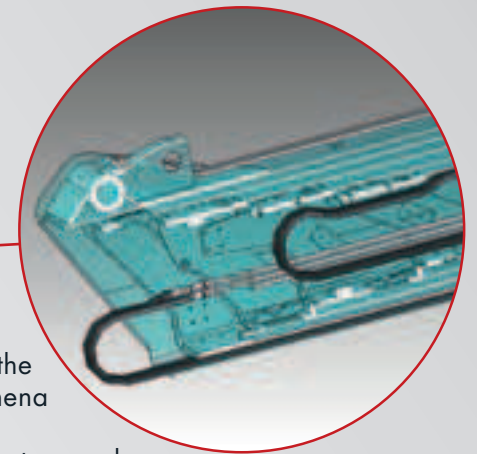
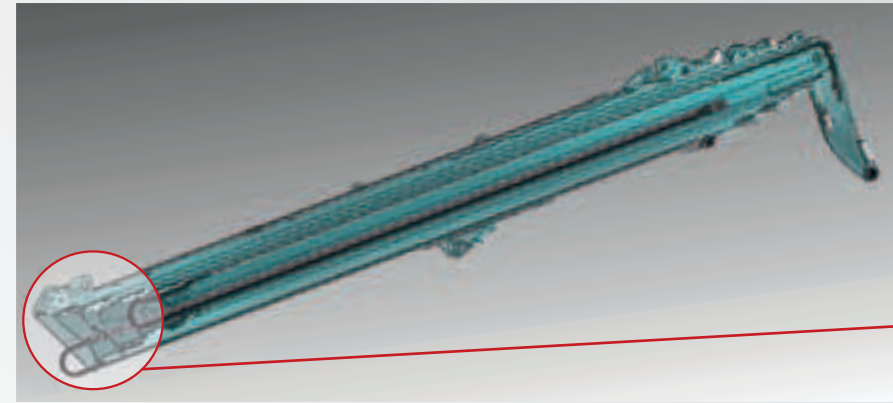
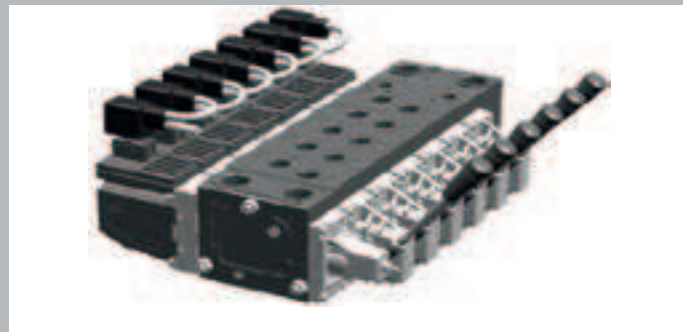

Made of high tension steel, the boom is extremely **sturdy** and **rigid**, and at the same time **very light**, giving more capacity and **avoiding flecion** phenomena on the long reach.

The telescoping of boom sections is actuated by a cylinder, a double chains system and hydraulic hoses completely placed inside the boom itself with a patented **mono-block of 6 hoses** glued together, reducing the exposure to accidental breaks due to possible collisions. The 6 mono-block hoses also avoid scratches and tangling between them inside the boom, granting less breaks and so less risk of machine time stops.

The sliding pads inside Magni TH's booms equip stainless steel blocks to fix them to the boom to ensure that the screw which keeps pads in their place will not break them in case of excessive friction.



The IP67 electric circuit grants protection against infiltration of external agents, like water and dust, and is **24 V**. The machine is equipped with a **CAN BUS** circuit that collects all the data about the electronic components, allowing to display on the touch screen all the information about the engine, transmission, hydraulics and load monitoring system. CAN BUS technology requires 1/3 less wiring going round the machine whit a result of less failures risk on the circuit and an increased reliability.

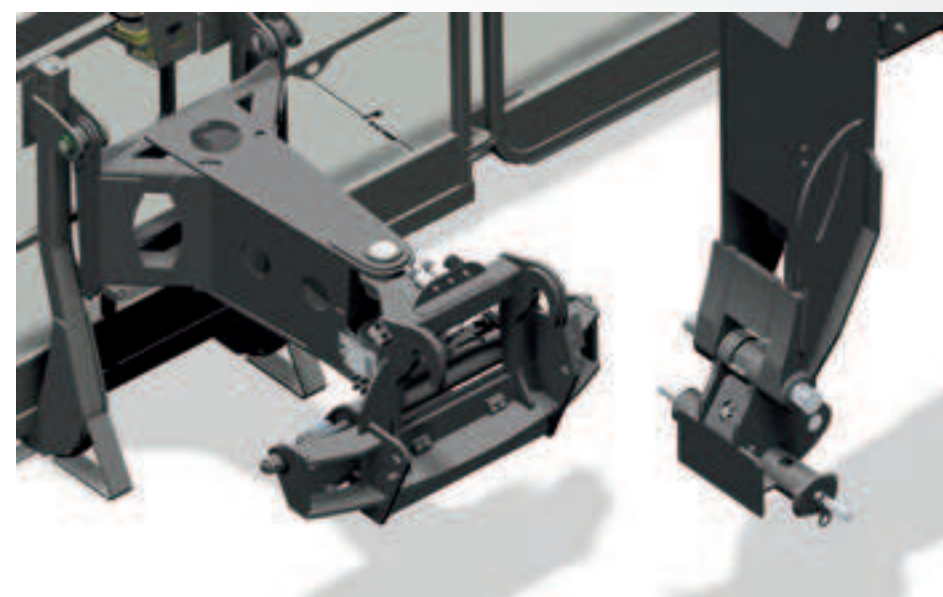
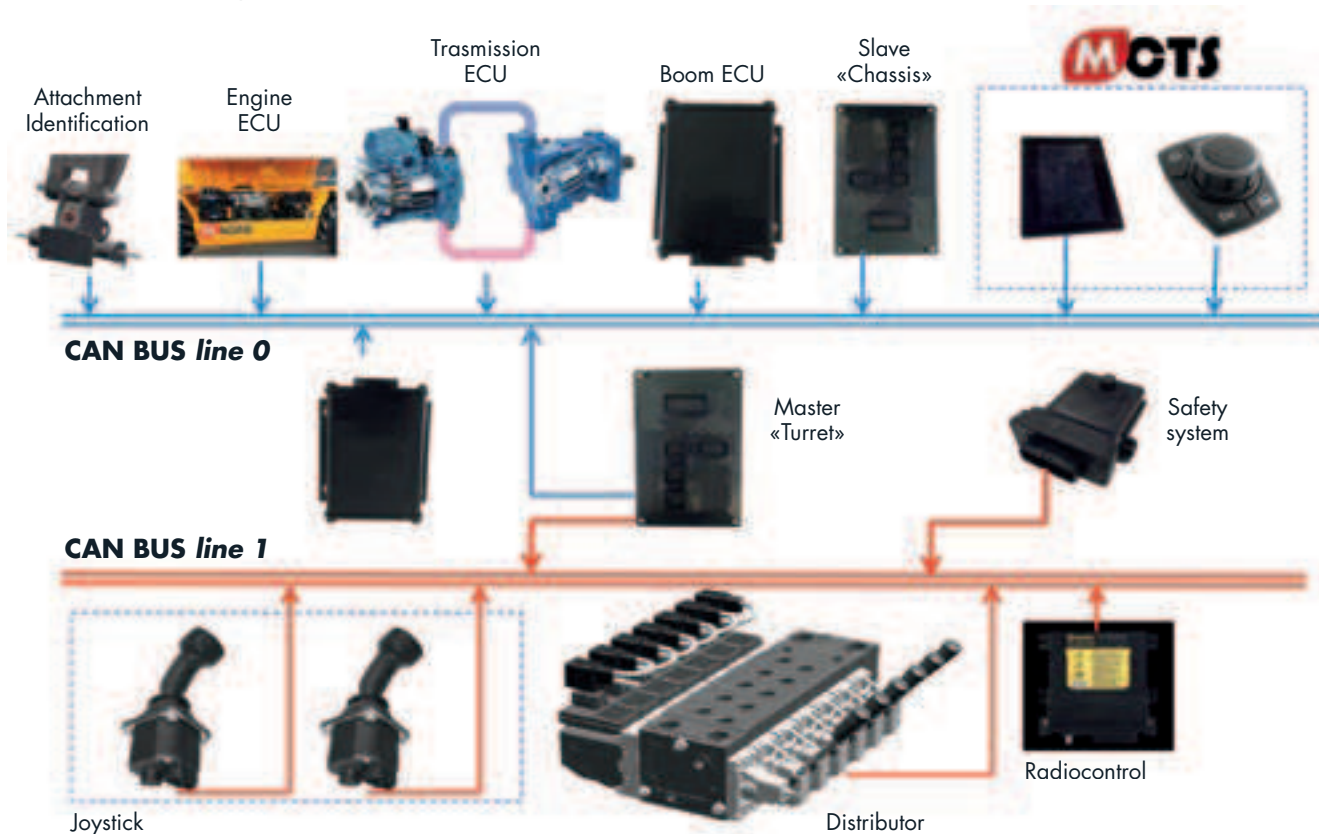

Thanks to the lighter weight, the new quick-fit system improves capacity performances. A system of automatic recognition of the attachment is equipped on every Magni machine; on the boom head there is a **R.F.I.D. system** that automatically recognize the fitted tool in use when it is coupled to the machine and consequently loads the diagram relative to the attachment and prearrange the load limit device to work with that specific attachment. This makes the machine much safer and prevents human error in selecting the fitted attachment.



The compact size of the chassis is accentuated by the pivoting stabilizers that are realized on the same axis; when outriggers are closed they are perfectly in gauge with the machine shape and do not reduce ground clearance. When outriggers are opened instead, guarantee a very compact stabilizing area, of just 427 cm, even though maintaining impressive lifting performances. The performances of Smart Series are highlighted by the wheelbase of 3000 mm that ensures also more advantageous capacities on tyres, while compactness is assured by the increased tyres steering angle, thanks to which also the turning radius of the machine has been kept favorable to allow maneuvering even in tight spaces.

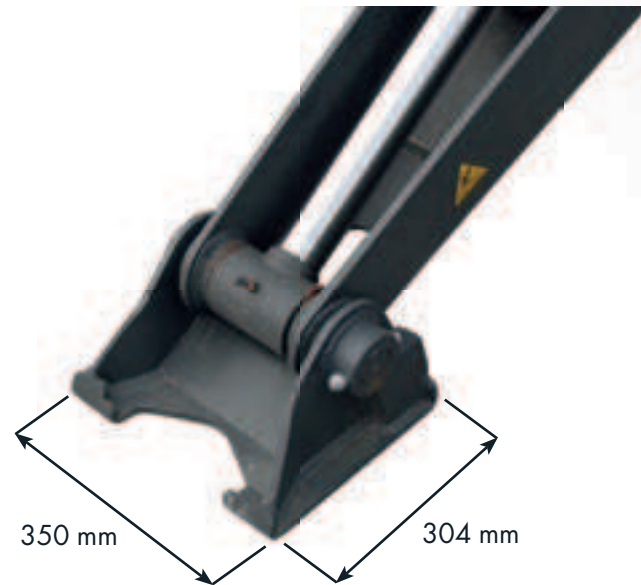

The outriggers lifting and lowering process allows an optimal leaning to any kind of ground thanks to their wide surface; at the same it grants the automatic shutting in gauge of the outriggers pads.



Scissors stabilizers are perfectly in gauge when closed and do not affect the ground clearance; their superposed beams fixed on chassis to avoid affecting ground clearance. Outriggers can be managed simultaneously or individually to perfectly adapt to working place.

The outriggers extension and retraction process allows an optimal leaning to any kind of ground thanks to their wide surface also avoiding the risk of sinking into the ground; at the same it grants the automatic shutting in gauge of the outriggers pads.

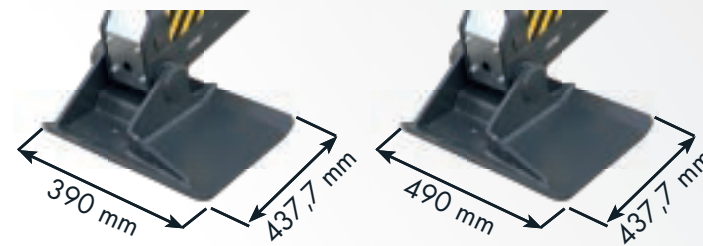

5.21 Smart S
5.23 Smart S
5.25 Smart S

5.26S - 5.30S
5.35S - 5.39S
6.24S



Turret perfectly in gauge even when rotated, for easy maneuvering in tight spaces.

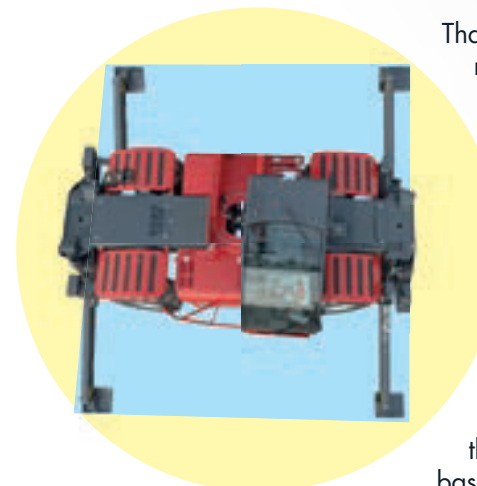

Thanks to their great flexibility scissors outriggers do not require much space to stabilize the machine; and even if partially stabilized the machine is programmed to provide the best possible load chart on each side of the machine. In fact inside each outrigger is placed a potentiometer that measure the stabilizer's extension (from 0% up to 100%) and basing on those data the software dynamically produces a virtual working area inside which are granted the best possible load chart with that configuration and operations safety. When completely extended the stabilizers grant the best performances on all 360° since the outrigger base is a square.

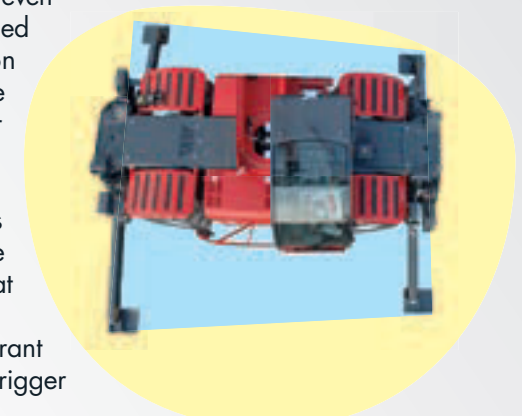

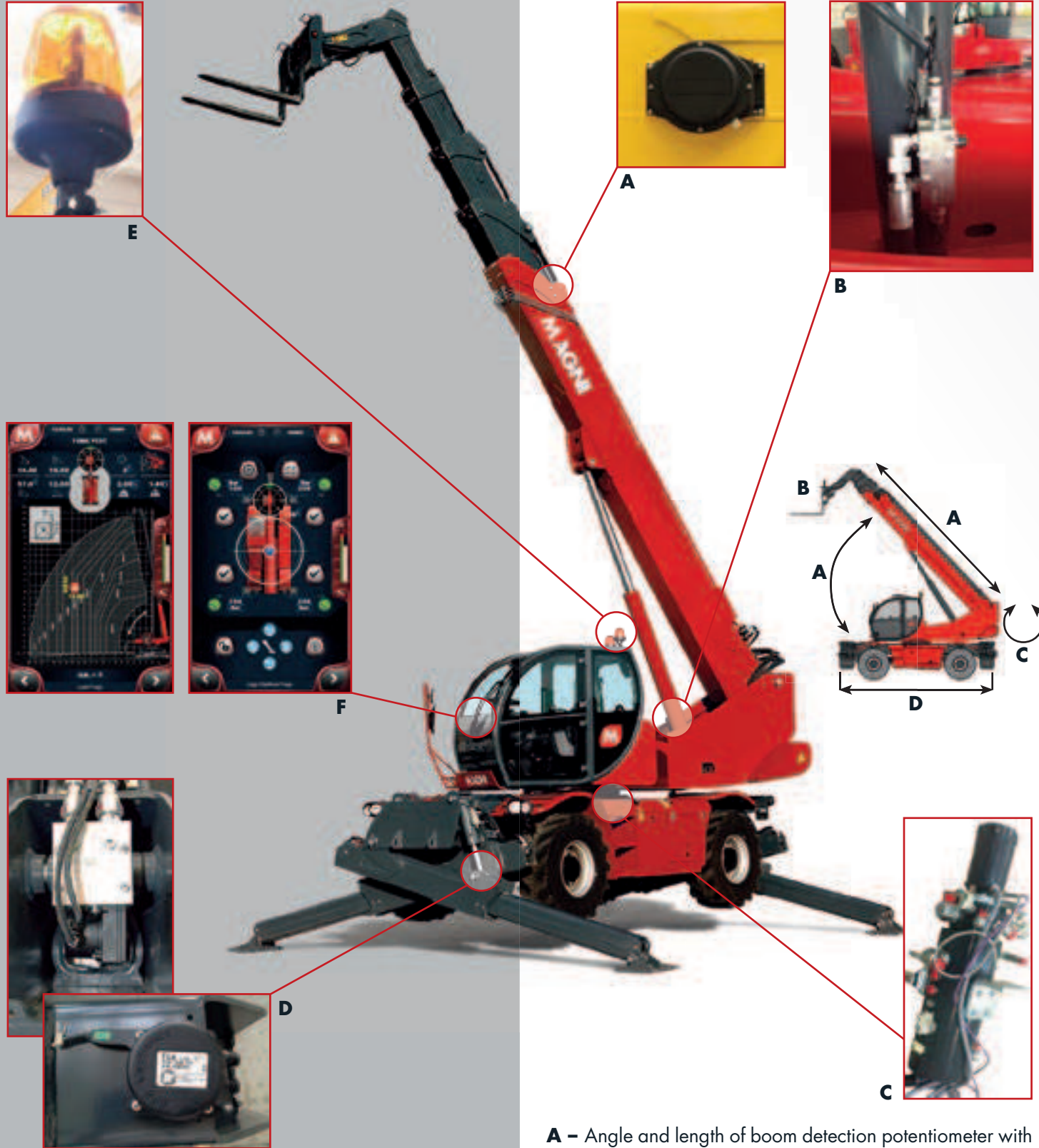

- A** – Angle and length of boom detection potentiometer with redundant safety
- B** – Weight detection of the load through 4 pressure transducers: 2 placed on lifting cylinders and 2 on compensation cylinder
- C** – Detection of turret position made by rotation sensors placed inside the rotating joint
- D** – Automatic detection of outriggers configuration through potentiometers positioned inside beams in order to be protected.
- E** – Alarm light
- F** – Dynamic representation of all the collected data within the touch screen display for the operator.

In order to grant safety, all Magni THs comply to norms concerning machine control, cranes and platform regulations. In addition THs are equipped with a Load Limit Device which can store specific load charts for each fitted attachment, continuously analyzes the positioning of the load in the space and dynamically displays the correct load chart accordingly to the machine working configuration. If a overload occurs it cuts automatically any aggravating movement, allowing just retraction movements.







Magni Telescopic Handlers srl

Via Magellano, 22 - 41013 Castelfranco Emilia, Modena, Italia
Tel: +39 059 8630811 - Fax: +39 059 8638012
commerciale@magnith.com - www.magnith.com

The data in this brochure are informative and subject to change without notice

