

Manitex



1970C BOOM TRUCK

MAXIMIZE RENTAL USE AND VALUE

The 1970C boom truck strikes the perfect balance between the three things customers tell us they care about most in a rental crane: features and cost and ease of use.

It's one of the highest-capacity cranes available on a 4x2 chassis, yet it's competitively priced and packed with standard features designed to save time and money.

Key features include a two-speed planetary hoist that lets operators can change line speed on the fly, and self-lubricating boom slider pads to minimize maintenance costs.

1970C at a Glance



Rated capacity: 19-ton (17 mt)



Max. boom length: 70 ft. (7.74 m)



Max. tip height: 80.7 ft. (10 m)

ELIMINATE THE LEARNING CURVE

The 1970C incorporates familiar, easy-to-use controls and built-in safety features that allow operators to get up and running quickly and with confidence.



USER-FRIENDLY CONTROLS

Dual operator stations are equipped with engine start/stop, foot throttle, signal horn, boom angle indicator, load chart and range diagram.

OUTRIGGER DEPLOYMENT

An audible alarm sounds as outriggers are being deployed, and indicator lights verify when they are fully extended.

LOAD MOMENT INDICATOR

The load-moment indicator sounds a warning and shuts down the machine when lift limitations are about to be exceeded.

CRANE WEIGHT

Gross vehicle weight (less jib): 27,750 lbs. (12,587 kg)

CRANE CAPACITY: On Outriggers

Capacity @ 5 ft./Over 360° 38,000 lbs. (17,236 kg)

Capacity @ 10 ft./Over 360° 22,330 lbs. (10,854 kg)

Capacity @ 20 ft./Over 360° 10,600 lbs. (4,808 kg)

DIMENSIONS

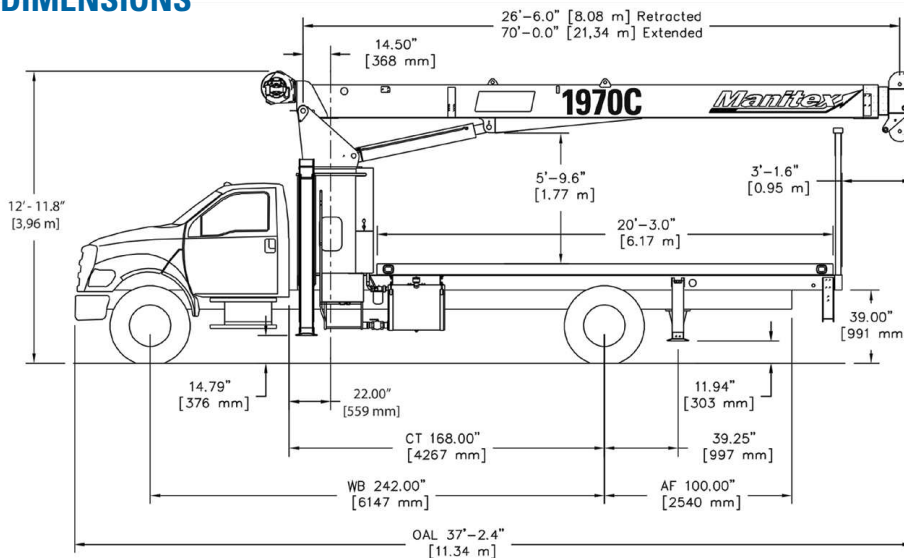

Uptime is the Manitex commitment to complete support of thousands of units working every day.

What does Uptime mean to Manitex customers?

- Uptime - means reliability.
- Uptime - means utilization.
- Uptime - means profitability.

