

**Manitex**



**50155GT**

**50-ton (45.3mt) RUBBER TRACKED CRANE**  
**50155GT SERIES PRODUCT GUIDE**



















# CONTENTS

















Crane Features.....	4
Prinoth Specs.....	5
Crane Dimensions.....	6
Boom Diagram.....	7
Load Chart.....	8
Load Chart.....	9
Jib Chart.....	10
Technical Descriptions & Options.....	11

Data published herein is intended as a guide only. Crane operation is subject to the computer charts and operation manual supplied with the crane.



# KEY

	Operator aids / Load limiter / Indicator
	Cab
	Heating/Air conditioning
	Controls
	Hoist line speed
	1 - Main hoist 2 - Auxiliary winch
	Rope length
	Rope - Standard/optional
	Rope diameter
	Permissible line pull
	Maximum line pull
	Slewing / Allowable slewing range
	Slewing gears
	Slewing brake
	Outriggers / Lifting on outriggers
	Removable counterweight system
	Counterweight
	Radio remote control

	Hook block
	Distance from hook to head sheave pin
	Hook and ball
	Hydraulics
	Max. boom length with extension
	Boom extension with offset
	Boom angle
	Telescoping mode
	Working radius
	Boom length
	Hydraulic actuated boom
	Mechanical synchronized
	Boom head / Hook block dimension
	Main boom with auxiliary head
	Tip height
	2-Person man basket

Data published herein is intended as a guide only. Crane operation is subject to the computer charts and operation manual supplied with the crane.

# THE 50155GT RUBBER TRACKED CRANE

## CONQUER CHALLENGING ENVIRONMENTS.

The new Manitex 50155GT Rubber-Tracked Crane is the highest-capacity crane ever mounted on a rubber-tracked carrier.

With its wide tracks, 50-ton capacity and 200-foot tip height, the 50155GT is designed not to exceed 4.5 lbs. per square inch of pressure (psi) so you can:

- Traverse rough terrain to construct and maintain non-energized electrical transmission lines
- Operate in soft, marshy or muddy ground within mines to perform routine maintenance where traditional "wheeled" cranes cannot operate effectively

Plus, with an overall height of under 11-feet, 1-inch the crane can be hauled to and from worksites without having to obtain costly over-height transportation permits.

**The new 50155GT combines proven components from three industry leaders:**

- The upperworks of a Manitex 50155 truck mounted crane
- A low-profile pedestal
- Prinoth® Go-Tract® 4500 tracked carrier

## THE BEST OF ALL WORLDS



With the 50155GT, you can:

- **Conquer challenging environments.** The unit's lightweight, 43-inch wide tracks keep ground-bearing pressure to about 4.5 psi, so you can travel on soft or marshy ground.
- **See clearly.** The 50155GT cab tilts up as much as 20° so the operator can see the boom clearly and without neck strain.
- **Reach farther/lift more.** With its outriggers fully extended, the 50155GT can lift 50 tons at 6' radius and has the ability to lift a two-person work platform to a height of 200 feet.
- **Lift confidently.** The built-in full-color load-moment indicator sounds a warning or interrupts boom functions when lift limitations are exceeded.
- **Avoid over-height permits and fees.** With an overall height of just under 11'1" you can haul the crane to and from worksites without having to obtain costly over-height permits.
- **Meet the latest EPA tiered engine requirements.** The Caterpillar® C9 Tier 3 diesel engine complies with the newly established U.S. Environmental Protection Agency (EPA) air emissions standards.

# PRINOTH SPECS

## DIMENSIONS

Shipping weight (basic vehicle)	15,678 kg (34,563 lb)
Overall length without extension	7,488 mm (295 in)
Overall width	3,480 mm (137 in)
Overall height	3,043 mm (119,8 in)
Ground clearance	533 mm (21 in)

## PERFORMANCE

Payload	20,865 kg (46,000 lb)
Maximum speed	10 km/h (6.3 mph)
Fording depth	1,219 mm (48 in)
Turning radius	0 m (0 ft)
Ground pressure @ 150 mm (6 in) penetration	
Basic vehicle	135 g/cm <sup>2</sup> (1.9 psi)
Loaded vehicle	310 g/cm <sup>2</sup> (4.4 psi)
Maximum gradeability	
Uphill/downhill	60% (31°)
Sidehill	40% (21.8°)

## ENGINE

Make	Caterpillar
Model	C9
Type	Turbo diesel, electronic fuel system, EPA Tier 3 and EU Stage IIIA
Number of cylinders	6
Displacement	8.8 L (537 in <sup>3</sup> )
Horsepower @ 2,200 RPM	280 kW (375 hp)
Torque @ 1,400 RPM	1,668 N·m (1,230 lb·ft)

## TRANSMISSION

	<b>Make</b>
Pump drive	Funk
Hydrostatic pumps	Sauer-Danfoss
Hydrostatic motors	Rexroth
Planetary gearboxes	Fairfield

## CONTROLS

Type	Microcontroller with color display
Inputs	Steering wheel, progressive forward, neutral, reverse lever, and speed pedal
Outputs	Independent control of each track
Other features	Anti-stall, fault code diagnostic and auto-calibration

## ELECTRICAL SYSTEM

Voltage	12 V
Alternator	145 A
Battery capacity	3 x 1,010 CCA

## UNDERCARRIAGE

Type	Walking beam
------	--------------

## WHEELS

Quantity	10
Type	Solid
Dimensions	221 mm x 920 mm (8.7 in x 36.2 in)

## TRACKS

Type	D-dent, hardened steel
Width	1,092 mm (43 in)
Belt	Rubber, 7 plies
Tensioner	Grease-filled cylinder

## CHASSIS

Type	Tub
Drain plug	Yes
Access panels	Yes

## CAPACITIES

Cooling system	38 L (10 US gal)
Fuel tank	455 L (120 US gal)
Hydrostatic tank	63 L (16 US gal)

## PROVISION FOR EXTRA HYDRAULIC PUMP

Location	Top pad on triple pump drive
Flange type	SAE B – 4 in diameter pilot
Shaft type	SAE B – 13 teeth, 16/32 pitch
Direction of rotation	CCW (when looking at pump shaft)
Max. rotational speed	3,058 RPM

## OPTIONAL EQUIPMENT

- Rear pintle hook
- External mirrors (heated available)
- Amber beacon light with protector
- Remote-controlled directional spotlight
- Electronic inclinometer
- Air conditioning
- Maintenance kit, 500 h or 2 000 h, includes all filters for air/fuel/hydrostatic
- Radio CD AM/FM
- Toolkit
- First aid kit
- ESPAR D5 engine coolant heater, with a 7-day timer
- Satellite boosting lug
- Spare parts kit
- Dash display module with rear view camera
- Custom options available upon request: winch, blade, dump box, etc.
- Tool for track installation



## GO-TRACT™ 4500 TECHNICAL DATA

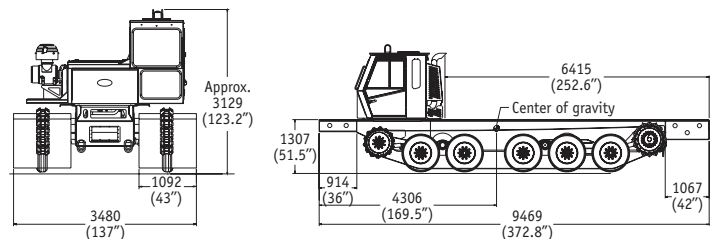

Optional equipment shown

Sales and service sites in your area can be found on [www.prinOTH.com](http://www.prinOTH.com)

Copyright © 2012. All Rights Reserved. Subject to modifications in the course of technological advancement. PRINOTH® and Caterpillar® are registered trademarks.

# CHASSIS DIMENSIONS

## SIDE VIEW ON GROUND

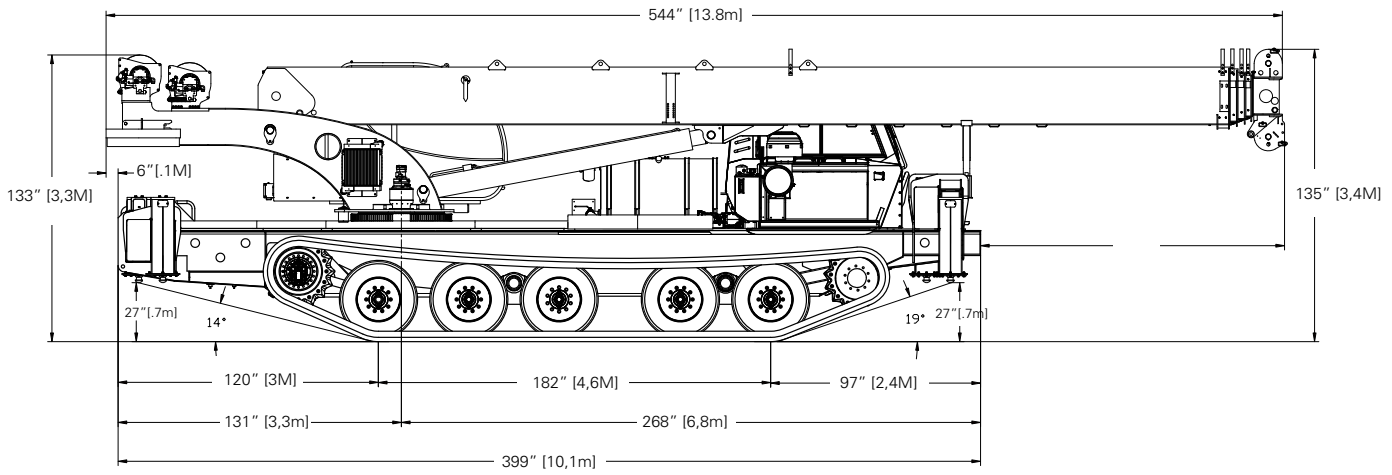

## SIDE VIEW ON OUTRIGGERS

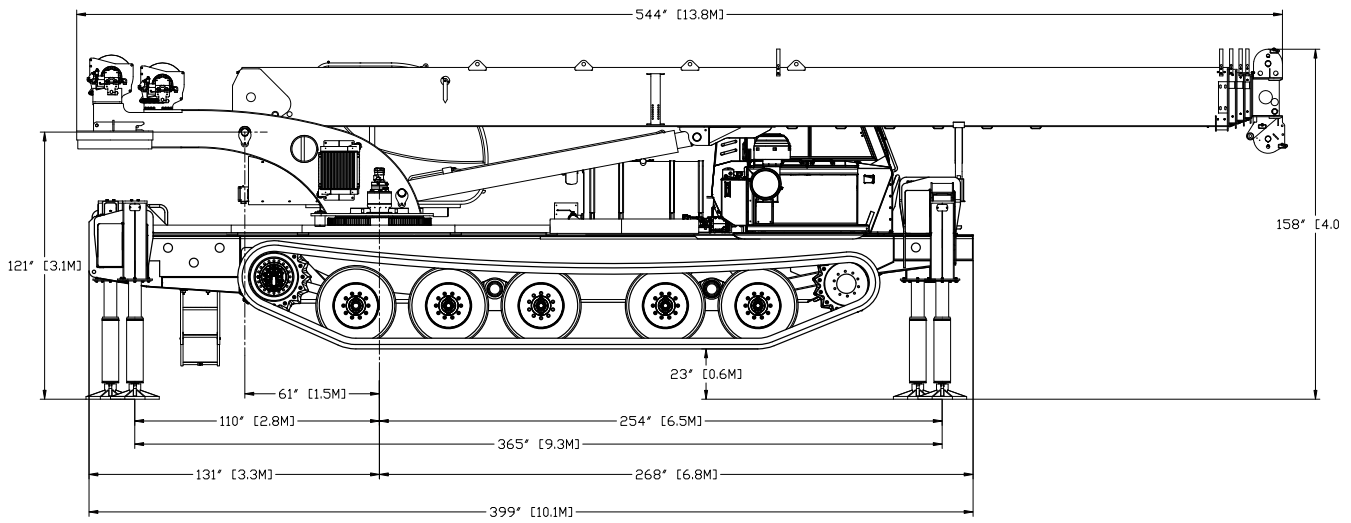

## TOP VIEW

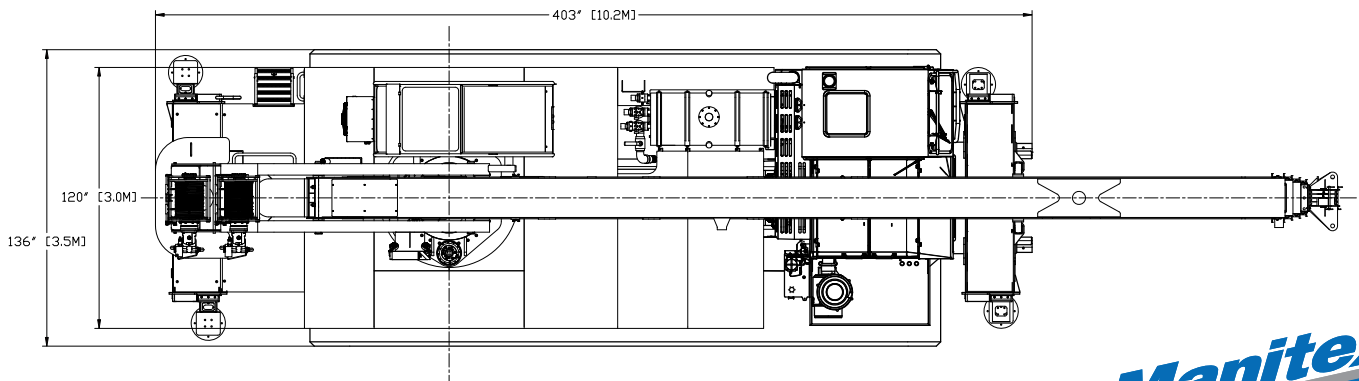



# BOOM DIAGRAM

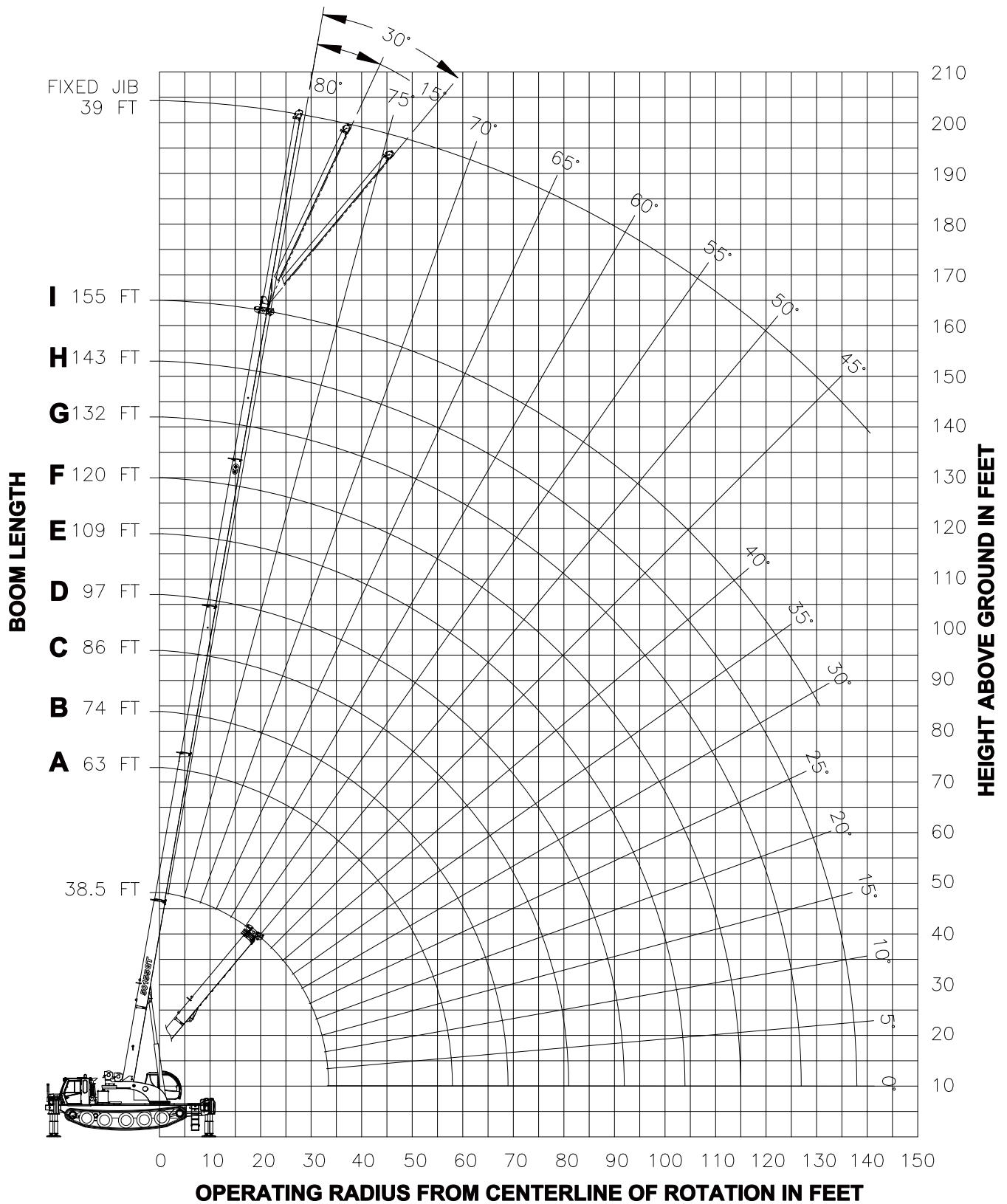







Data published herein is intended as a guide only. Crane operation is subject to the computer charts and operation manual supplied with the crane.

# LOAD CHART: Main Boom

Lifting Capacities 5 Section Boom 38.5 ft. - 155 ft.

 23 ft. 3 in.

 360°

	38.5 ft. Boom		63 ft. Boom		74 ft. Boom		86 ft. Boom		97 ft. Boom	
		360° Deg (lbs.)		360° Deg (lbs.)		360° Deg (lbs.)		360° Deg (lbs.)		360° Deg (lbs.)
6 ft.	74.5	100,000								
8 ft.	71	85,500								
10 ft.	68	74,200	77.5	40,000						
12 ft.	64.5	65,500	75.5	40,000	78.5	37,700				
15 ft.	59.5	55,400	73	40,000	76	36,340	78.5	31,000		
20 ft.	50	43,200	68	38,250	72	33,380	75	28,200	77.5	24,120
25 ft.	39.5	33,800	63	34,200	68	30,620	72	25,970	74.5	22,200
30 ft.	25	24,510	57.5	26,940	63.5	27,220	68	23,950	71.5	20,480
35 ft.			51.5	20,820	59	21,080	64.5	21,290	68.5	18,670
40 ft.			45.5	16,560	54	16,820	60.5	17,010	65	17,150
45 ft.			38.5	13,410	49	13,680	56	13,870	61.5	14,000
50 ft.			30	10,990	43	11,270	52	11,460	58	11,590
55 ft.			18.5	9,050	37	9,350	47.5	9,550	54	9,680
60 ft.					29.5	7,790	42.5	8,000	50	8,130
65 ft.					20	6,480	37	6,710	46	6,840
70 ft.							30.5	5,620	41.5	5,760
75 ft.							23	4,690	36.5	4,840
80 ft.							10	2,570	30.5	4,030
85 ft.									23.5	3,330
90 ft.									13	2,190
STOWED JIB	960 lbs.		590 lbs.		500 lbs.		430 lbs.		390 lbs.	
ERECTED JIB	2,620 lbs.		2,270 lbs.		2,190 lbs.		2,130 lbs.		2,080 lbs.	
DEDUCTIONS FOR MAIN BOOM CAPACITIES										

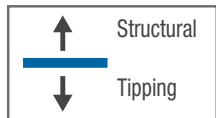

**NOTES:**

- All loads rated at 360° pick
- Loads based on crane on outriggers
- All "on outriggers" loads are based on 85% tipping
- Loads above heavy line are based on structural rating
- Loads below heavy line are based on tipping rating

Data published herein is intended as a guide only. Crane operation is subject to the computer charts and operation manual supplied with the crane.









# LOAD CHART: Main Boom

Lifting Capacities 5 Section Boom 38.5 ft. - 155 ft.

 23 ft. 3 in.

 360°

	109 ft. Boom		120 ft. Boom		132 ft. Boom		143 ft. Boom		155 ft. Boom	
		360° Deg (lbs.)		360° Deg (lbs.)		360° Deg (lbs.)		360° Deg (lbs.)		360° Deg (lbs.)
25 ft.	77.5	18,000	79	16,260						
30 ft.	74.5	17,000	76.5	15,280	78.5	13,500	80	11,500		
35 ft.	71.5	15,920	74	14,270	76.5	12,900	78	11,300	79	9,000
40 ft.	68.5	14,700	71.5	13,310	74	12,000	76	11,000	77	9,000
45 ft.	65.5	13,570	69	12,410	71.5	11,300	74	10,460	75.5	9,000
50 ft.	62.5	11,690	66.5	11,600	69.5	10,550	71.5	9,460	73.5	8,800
55 ft.	59.5	9,780	63.5	9,850	67	9,610	69.5	8,880	72	8,320
60 ft.	56.5	8,230	60.5	8,300	64.5	8,360	67.5	8,330	70	7,820
65 ft.	53	6,950	57.5	7,020	62	7,080	65.5	7,120	68	7,160
70 ft.	49.5	5,870	54	5,940	59	6,000	62.5	6,040	65.5	6,080
75 ft.	46	4,940	51	5,020	56	5,080	60	5,120	63.5	5,160
80 ft.	42	4,150	47.5	4,220	53	4,280	57	4,330	61	4,360
85 ft.	37.5	3,450	44	3,530	50	3,590	54.5	3,630	58.5	3,670
90 ft.	32.5	2,830	40	2,910	47	2,980	52	3,020	56	3,060
95 ft.	26.5	2,280	36	2,370	43.5	2,430	49	2,480	53.5	2,520
100 ft.	18.5	1,780	31.5	1,880	40	1,950	46	1,990	51	2,030
105 ft.			26.5	1,440	36	1,510	43	1,560	48.5	1,600
110 ft.			19	1,030	32	1,110	39.5	1,160	45.5	1,210
115 ft.					27	750	36	810	43	850
120 ft.										
STOWED JIB	340 lbs.		310 lbs.		280 lbs.		260 lbs.		240 lbs.	
ERECTED JIB	2,050 lbs.		2,020 lbs.		1,990 lbs.		1,970 lbs.		1,950 lbs.	
DEDUCTIONS FOR MAIN BOOM CAPACITIES										

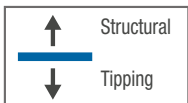

**NOTES:**

- All loads rated at 360° pick
- Loads based on crane on outriggers
- All "on outriggers" loads are based on 85% tipping
- Loads above heavy line are based on structural rating
- Loads below heavy line are based on tipping rating

## AREA OF OPERATION

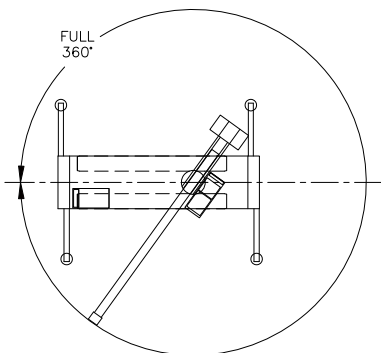

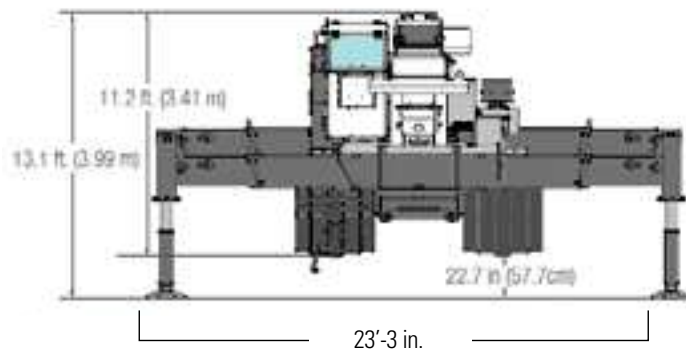

## DIMENSIONS



# JIB CHART

## 39 ft. Fixed Jib - 0° Offset - O/R's Extended



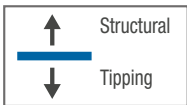







	LMI CODE 8 – 0° Offset		LMI CODE 10 – 15° Offset		LMI CODE 12 – 30° Offset	
		360° Deg (lbs.)		360° Deg (lbs.)		360° Deg (lbs.)
40 ft.	79.5	4,000				
45 ft.	78	4,000				
50 ft.	77	4,000	79.5	4,000		
55 ft.	75.5	4,000	78	4,000		
60 ft.	74	4,000	76.5	4,000	79.5	4,000
65 ft.	72.5	4,000	75	4,000	77.5	4,000
70 ft.	71	4,000	73.5	4,000	76	4,000
75 ft.	69.5	4,000	72	4,000	74.5	3,880
80 ft.	68	4,000	71	3,940	73	3,730
85 ft.	66.5	3,360	69.5	3,780	71.5	3,570
90 ft.	64.5	2,750	67.5	3,350	70	3,430
95 ft.	63	2,210	66	2,760	68	3,230
100 ft.	61	1,740	64.5	2,250	66	2,670
105 ft.	59	1,310	62	1,780	64.5	2,170
110 ft.	57	930	60	1,370	62.5	1,720
115 ft.			58	990	60.5	1,310
120 ft.					58	940



**NOTES:**

- All loads rated at 360° pick
- Loads based on crane on outriggers
- All "on outriggers" loads are based on 85% tipping
- Loads above heavy line are based on structural rating
- Loads below heavy line are based on tipping rating

## REEVING DIAGRAM

ALLOWABLE LINE PULL										<b>WARNING</b>
1 PART LINE	2 PART LINE	3 PART LINE	4 PART LINE	5 PART LINE	6 PART LINE	7 PART LINE	8 PART LINE	9 PART LINE	10 PART LINE	
										
10000 LBS	20000 LBS	30000 LBS	40000 LBS	50000 LBS	60000 LBS	70000 LBS	80000 LBS	90000 LBS	100000 LBS	<p>ANTI-TWO-BLOCK SYSTEM MUST BE IN GOOD OPERATING CONDITION BEFORE OPERATING CRANE.</p> <p>REFER TO THE OWNER'S MANUAL.</p> <p>KEEP AT LEAST 3 WRAPS OF LOAD LINE ON THE DRUM AT ALL TIMES.</p>
<p>5/8" 6 X 19 CLASS (3.5:1 SF) 35,000 LBS MIN BREAKING STRENGTH</p> <p>5/8" ROT RESISTANT (3:1 SF) 50,000 LBS MIN BREAKING STRENGTH</p>										

# TECHNICAL DESCRIPTIONS & OPTIONS

## Boom

 Boom lengths: Proportional boom

- 5-section 155 ft. (47.2 m)

5-sheave quick reeve boom point  
Self lubricating slider pads

---

 Boom max. tip height: 157 ft. - 164 ft. (47,9 m - 50,0 m)

---

 Boom angle (min/max): -6° / 80°

## Rotation

 Ball-bearing swing circle with external gear  
Double-reduction planetary gearbox driven by hydraulic motor  
Selectable Free Swing or no Free Swing Switch

---

 Slewing brake: Spring-applied pressure released automatic brake

---

 Slewing speed: 1.5 - 2 rpm. (nominal)  
Boom rotation: 360° continuous

## Outriggers

 Outriggers: Out-and-down style  
Outrigger monitoring system (for verification only)  
Outrigger motion alarm  
Full extension

- Front and rear: 23.25 ft. (7,0 m)

---

 ROC Solid - Radio operated handheld controller for outrigger and FBS setup

## Operator aids

 Wired LMI with crane function cut-offs for overload protection, wired anti-two block system, graphical display, event recorder, WADS - Work Area Definition System

## Hoist, Rope and Hook

 Maximum theoretical line speed: 453 fpm (138 mpm)

 Maximum theoretical bottom-layer line pull: 13,050 lbs. (5,919 kg)

 Main winch cable diameter: 5/8 in. (15,9 mm) rotation resistant

 Line length: 500 ft. (152 m)

 Main winch: Bent axis 2-speed hydraulic motor (activated electrically)

 Load block: 5T (4.5 mt) capacity hook with heavy-duty swivel and weight is provided for single line operation.

## Hydraulics

 Hydraulic reservoir capacity: 155 gal. (587 L)  
3 Variable Flow Load Sensing Pump

## Tiltable Cab/Cab Controls

 Standard features:  
Curved glass, 0° to 20° cab tilt, Automotive door, heated cloth seat, 8 seat adjustments, lumbar support and adjustable head rest, sliding windows, rear pop out window, top hinged hatch, standard diesel fired heater, retractable sun screen, 12 volt DC outlet, E-coated cab (10 year rust warranty)

---

 Controls:  
PLC crane controller, CANBUS communication, J1939 truck engine communication capability, electronic hand and foot throttle, Hirschmann/PAT iScout D3 LMI system

## OPTIONS

### Hoist, Rope and Hook

Auxiliary winch same as main winch, includes rooster sheave  
2nd overhaul ball available  
3rd wrap limiter main and auxiliary winch

---

 Auxiliary lower sheave block for 2-9 part lines  
Load blocks 1-7, 4-8, 2-8, 9-10 part lines

### Boom

 1-section fixed jib: 39 ft. (11,8 m)  
Max tip height w/ext = 202 ft. (61,7 m)  
Max tip height w/ ext retracted: 157 ft - 164 ft (47,8m - 50 m)

### Cab

- Air conditioner
- Engine monitoring system
- Cab weather band radio system
- Video camera (1 or 2)
- Wireless wind speed indicator
- Work lights

### Operator Aids

 4-function radio remote crane control system either with paddles or joy sticks

- 900 Mhz
- 433 Mhz

Remote Winch Control System for main and auxiliary winches

### 2-Person Basket

 Consult Manitex for specific application and rating

- 2-person quick attach rotating basket
- Aluminum or Steel
- Aluminum Basket Capacity on Boom is 1200 lbs.

### Tool Boxes & Platforms

Tool Boxes

- 24 " L x 18" w x 18" H - Steel (610 mm L x 457 mm W x 457 mm H)
- 48 " L X 24" W x 24" H - Aluminum (1219 mm L x 610 mm W x 610 mm H)
- 48 " L X 24" W x 24" H - Aluminum Top MTD-Swing Door (1219 mm L x 610 mm W x 610 mm H)

**Manitex**



# 50155GT

50-ton (45.3mt) RUBBER TRACKED CRANE  
50155GT SERIES PRODUCT GUIDE

Uptime is the Manitex commitment to complete support of thousands of units working every day.

---

**MANITEX**

3000 South Austin Avenue  
Georgetown, Texas 78626

1-877-314-3390 | [www.Manitex.com](http://www.Manitex.com)