

# MANISCOPIC

**MT 1740**  
SLT & SLT ULTRA



- Maximum lifting height : 16.65 m
- Nominal capacity :  
4000 kg at 500 mm
- Maximum forward reach : 12.35 m
- Torque convertor
- 4 wheel drive - 4 wheel steer
- Hydraulic stabilizers
- Frame levelling

 **MANITOU**

Courtesy of Crane.Market

# MT 1740 SLT/SLT ULTRA

**Lift capacity** .....4000 kg  
 at 500 mm from forks heels.  
 Tipping load at maximum reach  
 with stabilizers .....957 kg  
 Tear out force with bucket  
 as per ISO 8313 .....7000 daN

**Lift height** .....16.65 m  
**Times :** unladen / loaded (in s)  
 Lifting .....15/16  
 Lowering .....10/9  
 Extension 1<sup>st</sup> and 2<sup>nd</sup> booms .....21.8/24.4  
 Extension 3<sup>rd</sup> boom (with stabilisers only) ..10.4/11.5  
 Retraction 1<sup>st</sup> and 2<sup>nd</sup> booms .....17.7/17.4  
 Retraction 3<sup>rd</sup> boom (with stabilisers only) .....9.7/8.7  
 Time unladen (in s)  
 Crowd .....5.3  
 Dump .....8.4

**Tyres**  
 440/80-24

**Forks (mm)**  
 Length .....1200  
 Width x thickness .....125 x 50  
 Maximum distance between forks .....1040  
 Carriage rotation .....124°

**Multidisc brakes - hydraulically assisted  
 on both axles**

**PERKINS Engine Turbo**  
 Type .....1104C- 44 Turbo  
 Capacity .....4 cylindres 4400 cm<sup>3</sup>  
 Power (ISO/TR 14396) :  
 at 2200 tr/mn .....100 HP/74.5 kw  
 Maximum torque (ISO/TR 14396) ..412 Nm at 1400 r.p.m.  
 Direct Injection  
 Water Cooling

**Transmission** .....Torque convertor  
 Electro-hydraulic reversing shift  
 4 gears forward and reverse  
 Maximum travel speed .....25 km/h

**Hydraulics**  
 Gear type .....260 bars/196 l/mn  
 Flow divider with priority to steering and brakes

**Capacities**  
 Cooling system .....18.5 l.  
 Engine oil .....11 l.  
 Hydraulic oil .....175 l.  
 Transmission oil .....16 l.  
 Fuel tank .....135 l.

**Weight unladen (with forks)** .....11220 kg  
**Overall width** .....2.42 m  
**Overall height** .....2.60 m  
**Turning radius (outside wheels)** .....4.17 m  
**Overall length** .....5.98 m  
**Ground clearance** .....0.48 m  
**Drawbar pull (unladen)** .....9700 daN

Under  
 EN 1459  
 annexe B

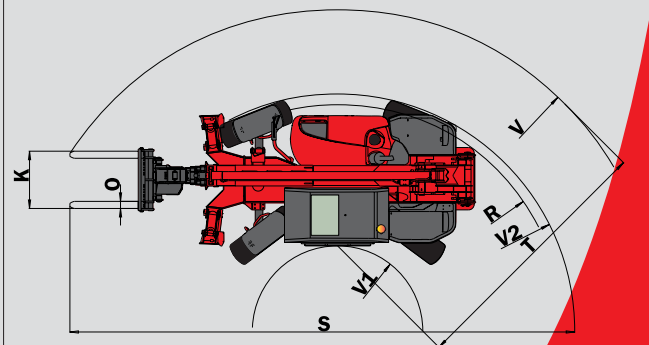
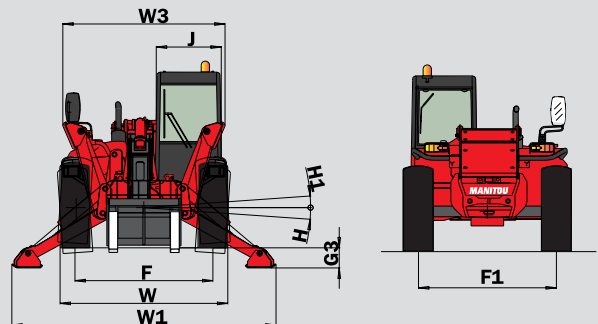
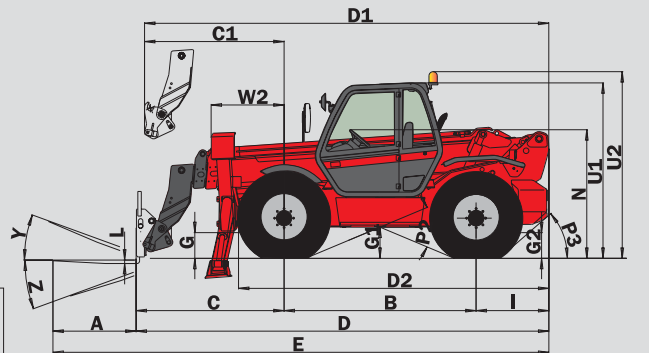
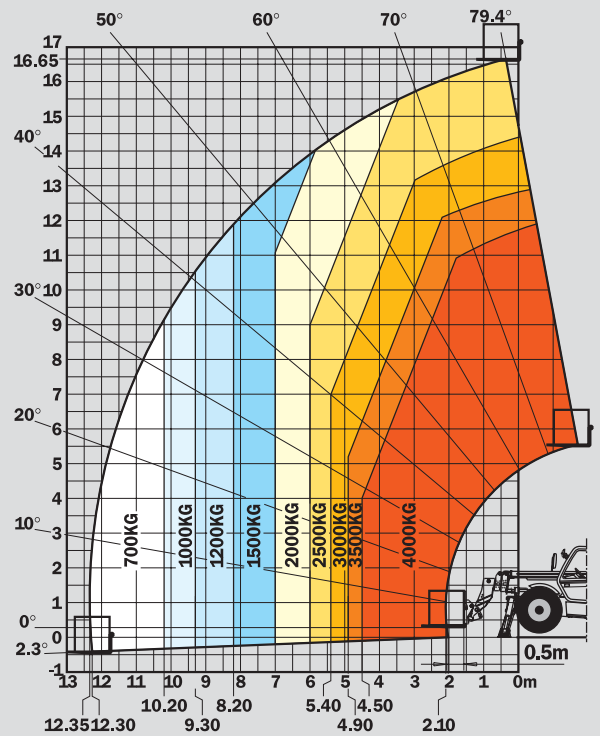

A	1200
B	2770
C	2160
C1	2232
D	5980
D1	6052
D2	4435
E	7180
F	1990
F1	1990
G	480
G1	475
G2	480
G3	290
H	7°
H1	7°
I	1050
J	950
K	1040
L	50
N	1880
O	125
P2	45,5°
P3	50°
R	3950
S	8912
T	4239
U1	2605
U2	2785
V	5709
V1	1470
V2	4168
W	2425
W1	3820
W2	1050
W3	2350
Y	12°
Z	112°

mm



This publication in no way constitutes an offer and the company reserves the right to alter specification without prior notice.  
 The MANITOU models presented in this brochure can be supplied complete with optional equipment attachments.  
 PATENTS FR 93 14367 - EP 0 656 315 US PENDING