

Manitowoc 16000

Product Guide

ASME B30.5

Metric

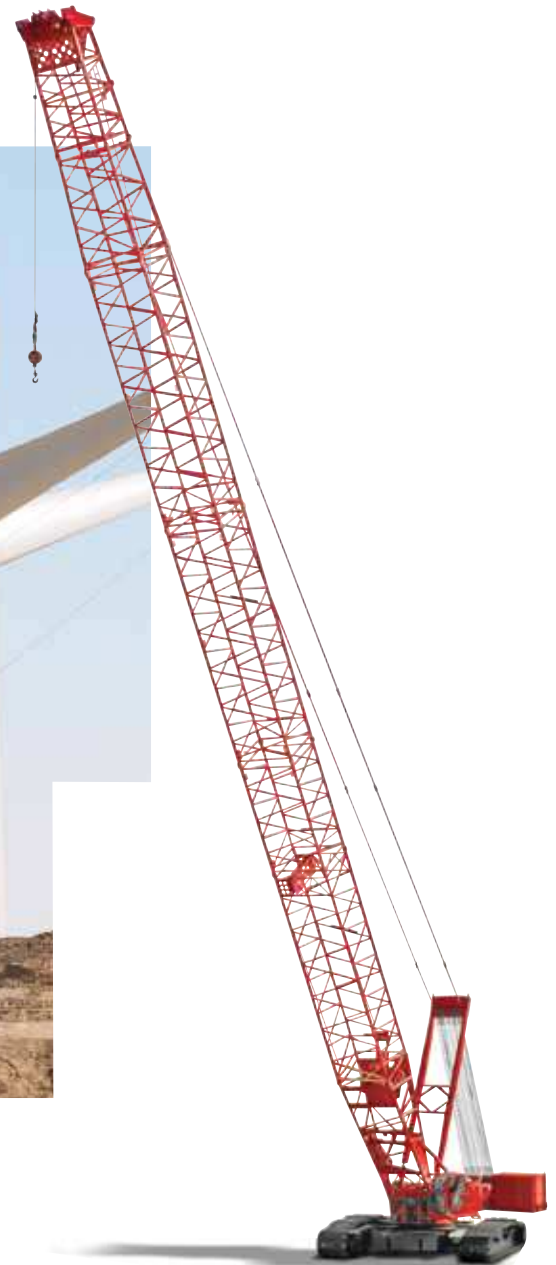

Features

- 400 t capacity
- 2 599 mton-m maximum load moment
- 5 066 mton-m maximum load moment with MAX-ER®
- 96 m No. 58 HL boom
- 105,6 m No. 133A fixed jib on No. 58 HL boom combination
- 138 m No. 59 luffing jib on No. 58 HL boom combination
- 372 kW engine

Features

EPIC®

Manitowoc's field-proven Electronically Processed Independent Controls (EPIC) system with CAN-BUS technology delivers high productivity and precise load control by instantly matching a crane's commands to the crane function. EPIC maximizes a Manitowoc crane's function capability and simplifies servicing by pinpointing any problem in the crane's engine, power transmission and other operating systems. In addition, EPIC increases versatility by easily tailoring a Manitowoc crane's operation for specialized applications, with or without attachments.



FACT™ Connectors

Manitowoc's Fast Aligning Connection Technology (FACT) precisely and accurately aligns crane components for safe, fast, easy assembly.



CraneSTAR

CraneSTAR is an exclusive and innovative crane asset management system that helps improve your profitability and reduce costs by remotely monitoring critical crane data. Visit www.cranestar.com for more information.

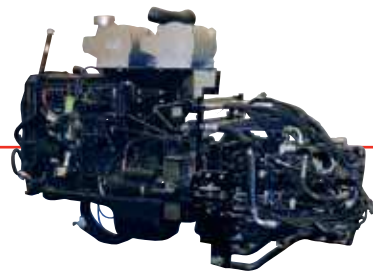

Hydraulics

Our closed-loop system provides a separate hydraulic circuit to power each crane function. The result is truly independent, variable-speed operation of the swing, load hoist, boom hoist and travel functions.

Contents

Specifications	4
Outline dimensions	7
Transport data	15
Crane assembly	16
Performance data	19
Boom combinations	24
Heavy lift boom range / load charts	27
Upper boom point range / load charts	29
Wind Attachment range / load charts	31
Fixed jib range / load charts	35
Luffing jib range / load charts	38
MAX-ER® complete information	42
Manitowoc Crane Care	56

Specifications

Upperworks



Engine

Cummins Model QSX15 – C500 Tier 4i/3b diesel, 372 kW (500 BHP) at 1800 RPM.

Or

Cummins QSX15-C500 Tier 3 diesel, rated 500 HP at 1800 RPM

Includes pump drive disconnect for easier starting, engine block heater (120V), ether starting aid, high silencing muffler, hydraulic oil cooler, radiator and fan.

Multiple hydraulic pump drive transmission provides power for all machine functions.

Two 12 volt, 1400 CCA at -18°C, 24 volt system and 100 amp alternator.

946 L, with level indicator in operator's cab.

► Optional: Cold-weather package with heater for fluids, and computer display.



Controls

Modulating electronic-over-hydraulic controls provide infinite speed response directly proportional to control lever movement. Controls include Manitowoc's exclusive EPIC® Electronically Processed Independent Control system with CAN-BUS technology providing microprocessor driven control logic, pump control, on-board diagnostics, and service information.

Block-up limit control is standard for hoist and whip lines.

Integrated Rated Capacity Limiter system (RCL) is standard for main boom and upper boom point. "Function cut-out" or "warning only" operation is selected via a keyed switch on the RCL console.

Travel and swing alarms are standard.

► Optional: Anemometer (wind speed indicator). Booms and jibs are pre wired for anemometer.



Hydraulic system

High-pressure piston pumps, driven by a multi-pump transmission, provide independent closed-loop

hydraulic power for the hoisting drums, boom hoist, swing, left crawler and right crawler.

719 L hydraulic reservoir is equipped with breather, clean out access, and internal diffuser.

Each function is equipped with relief valves to protect the hydraulic circuit from overload or shock.

System includes oil cooler and replaceable, full flow filter. All oil is filtered before entering the hydraulic pumps.



Drums

Basic machine is equipped with 108,6 cm wide and 64,1 cm diameter main hoist drum, mounted in the boom butt, and 82,2 cm wide and 64,1 cm diameter whip drum, mounted in the rotating bed. Each drum is driven by a variable-displacement hydraulic motor through a planetary reduction system. Drums are grooved for 28 mm rope.

Powered hoisting/lowering operation is standard with automatic (spring applied, hydraulically released) multi-disc brakes, and drum rotation indicators.

► Optional: Auxiliary (third) hydraulic powered drum rated 147 kN line pull mounted in boom butt.



Swing system

High strength steel adapter module is mounted on 3 m diameter triple row roller turntable bearing. Bearing adapter-mounted independent swing is powered by a fixed-displacement hydraulic motor coupled to an internal brake and planetary reduction.

Swing system maximum speed: 2.2 rpm.



Moving mast hoist system

Independent moving mast hoist with two grooved drums, each 32,5 cm wide and 64,1 cm diameter drum grooved for 1-1/8" diameter wire rope.

Drum is powered by variable-displacement hydraulic motors coupled to integral brake and planetary reduction gearboxes. Ratcheting pawl and rotation indicator are standard.

Raise 96 m full main boom from 0° - 82° in 3 minutes, 48 seconds.

Specifications



Boom support system

Moving Mast is 9,75 m long and connects the boom hoist reeving to the steel boom suspension strap rigging. When used with the optional self-erect package, the mast is used for crane assembly and disassembly. It is capable of lifting and positioning the crawler assemblies, stacking the counterweights, and assembling the boom and luffing jib.

Spring cushioned boom stop and automatic boom stop are standard.



Counterweight

Counterweight tray and counterweights for the upperworks attaches to the rotating bed with power actuated pins. Carbody counterweight connect to the carbody via high strength steel hooks integral with the carbody structure.

QTY.	ITEM	UNIT WEIGHT	TOTAL WEIGHT
		kg	kg
10	Upperworks Upper Side Box	8 164	81 640
1	Counterweight Tray	19 958	19 958
Series 1 Total			101 598
4	Upperworks Upper Side Box	8 164	32 656
2	Carbody Center Box	13 608	27 216
Series 2 Total			161 470
2	Upperworks Upper Side Box	8 164	16 328
4	Carbody Side Box	6 804	27 216
Series 3 Total			205 014



Vision operator's cab

The Vision Cab™ is a fully enclosed and insulated galvanized steel module mounted to the left front corner of rotating bed. Module is equipped with power tilt, sliding door, large safety glass windows, front and roof windshield wipers, dome light, sun visor and shade, fire extinguisher, air conditioning, swing and travel alarms, and radio/CD player. Operator's station swings over front of rotating bed for transportation.

- Optional: Nylon protective window covers.

Lowerworks



Carbody

Connects rotating bed to crawler assemblies. High strength fabricated steel assembly with FACT™ connection system for safe, fast installation and removal of crawler assemblies.



Crawlers

Crawler assemblies are 10,4 m long with 1,5 m wide cast steel crawler pads and automatically lubricated intermediate rollers. Each crawler is identical and can be mounted on either side of the carbody. Each crawler is powered independently by a variable displacement hydraulic motor and includes hydraulically powered pin actuators for fast installation and removal from carbody. Carbody mounted drive motors are connected to crawler final reduction via drive shaft with guard. Crawlers provide ample tractive effort for counter rotation with full rated load.

Maximum ground speed of 1,24 kph.

Attachments



No. 58 heavy-lift boom

The liftcrane is equipped with 30 m No. 58 basic boom consisting of 8 m butt, 12 m insert with luffing hoist sheaves, 5 m transition insert, and 5 m top with thirteen 76,2 cm diameter tapered roller bearing sheaves. Includes rope guides, boom hoist wire rope, boom angle indicator and hook and weight ball. The boom utilize Manitowoc's exclusive FACT™ connection system boom connector. Spring cushioned boom stop. Automatic boom stop. Powered boom hinge system including cylinder, piping, operating controls, and locking device standard.

- Optional: 6 m and 12 m No. 58 boom inserts with steel boom suspension straps.
- Optional: No. 58 detachable upper boom point with one 76,2 cm diameter tapered roller bearing steel sheave grooved for 28 mm rope with rope guard.
- Optional: 97,6 t detachable extended upper boom point with three 76,2 cm diameter tapered roller bearing steel sheave grooved for 28 mm rope with rope guard.

Specifications



No. 133A fixed jib

21,3 m basic No. 133A fixed jib including pin connected 9,1 m butt, 12,2 m top, 6,4 m strut and mounting hardware.

Optional: 3 m, 6,1 m and 12,2 m No. 133A inserts with pin connectors.

Utilize fixed jib inserts in combination with the No. 133A fixed jib length of 42,7 m.



No. 59 luffing jib

24 m basic No. 59 luffing jib including PIN connected 7 m butt, (1) 6 m inserts and 11 m top, basic pendants, fixed strut, jib strut, backstay pendants, boom point guide wheel, luffing jib hoist with ratchet and pawl; quick disconnect for jib hoist piping, and 1" luffing jib hoist line (luffing jib preparation is standard).

Optional: 6 m and 12 m No. 59 luffing jib inserts with steel boom suspension straps.

Utilize luffing jib inserts in combination with the No. 59 basic luffing jib for total luffing jib lengths up to 84 m.



The Wheeled MAX-ER®

The Wheeled MAX-ER® attachment components include:

30 m of No. 59A mast consisting of a 6 m butt, 6 m insert, 12 m insert and 6 m top.

One additional swing drive (for a total of two) mounted on the rotating module. Each swing drive is powered by a fixed-displacement hydraulic motor coupled to a planetary reduction gearbox and internal brake.

Two 12 m heavy No. 58 boom inserts.

Counterweight includes (8) 19 958 kg and (2) 13 608 kg boxes.

The wheeled MAX-ER® counterweight can be positioned 11 m, 13 m, or 15 m behind the crane's centerline of rotation, utilizing structural stinger equipped with hydraulic cylinder.



The Hanging MAX-ER®

The Hanging MAX-ER® attachment components include:

30 m of No. 59A mast consisting of a 6 m butt, 6 m insert, 12 m insert and 6 m top.

One additional swing drive (for a total of two) mounted on the rotating module. Each swing drive is powered by a fixed-displacement hydraulic motor coupled to a planetary reduction gearbox and internal brake.

Two 12 m heavy No. 58 boom inserts.

The hanging MAX-ER® counterweight assembly attaches to the top of the mast by steel straps and to the rear of the upperworks by a beam assembly.

Counterweight includes (10) 19 958 kg and (2) 6 804 kg boxes.

The hanging MAX-ER® counterweight can be positioned 11 m, 13 m, or 15 m behind the crane's centerline of rotation.

Optional equipment

18,1 t swivel hook and weight ball. Single line pull is 13 610 kg.

Self-erect system includes, jacking cylinders with pads, 41 t assembly block and crawler handling chains.

Hydraulic Test Kit: required to properly analyze the performance of the EPIC® control system.

Service Interval Kits for the regularly scheduled maintenance of general crane operations.

Special Paint color(s) other than Manitowoc standard red and black.

Custom vinyl decal(s) of customer name and/or logo from artwork supplied by customer.

Export Packaging: basic crane, boom and jib sections.

Additional load blocks available upon request.

Outline dimensions

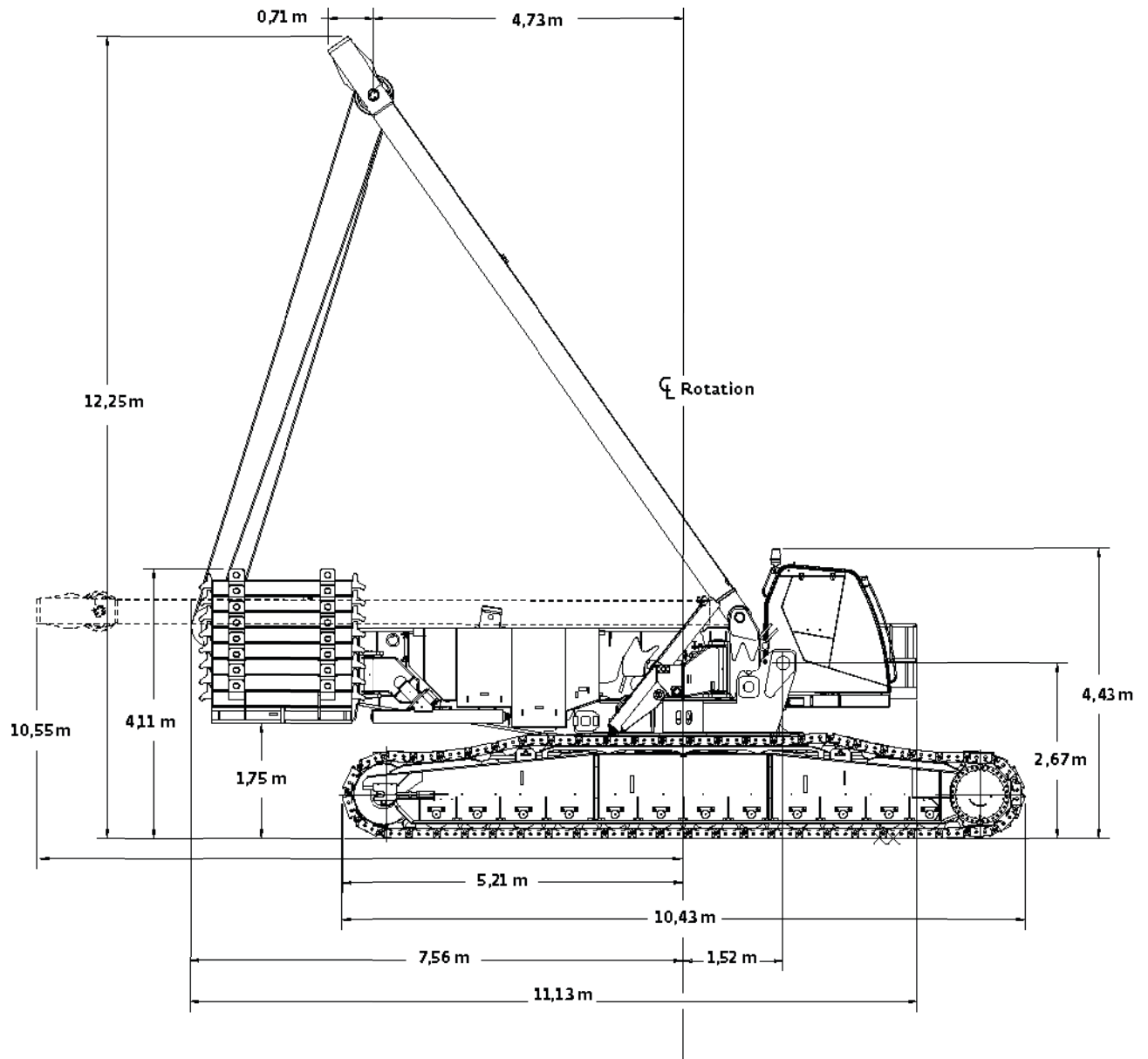

Outline dimensions

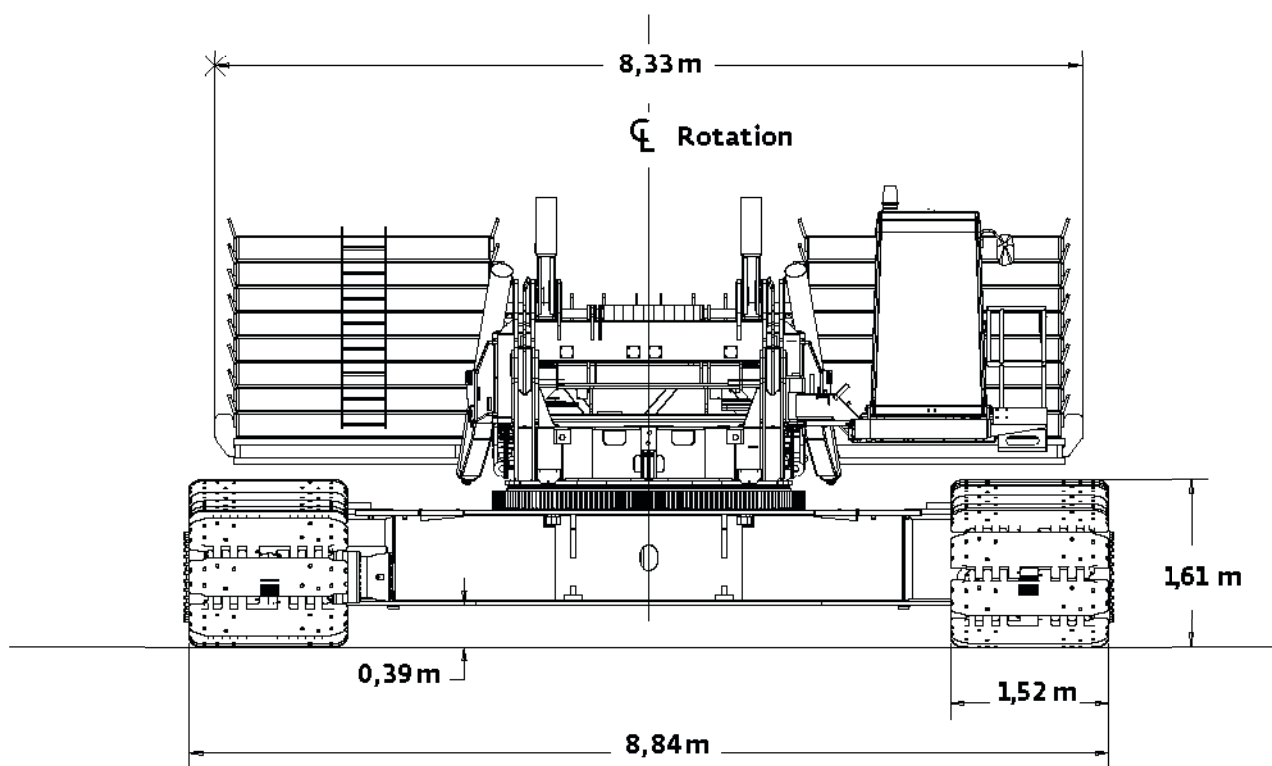

Outline dimensions

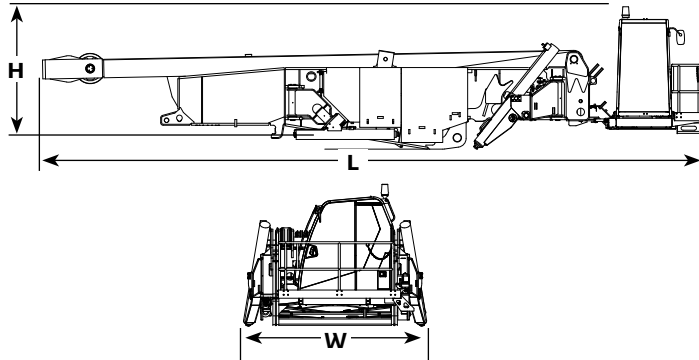

Rotating bed assembly

Length	13,25 m
Width	3,20 m
Height	2,87 m
Weight	39 612 kg

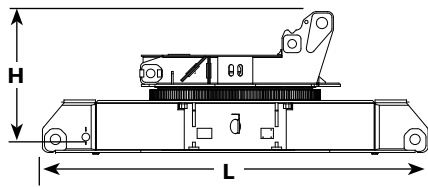

Carbody assembly

Length	6,78 m
Width	3,00 m
Height	2,52 m
Weight	28 161 kg

Note: Weight includes rotating bed adapter frame with bearing turntable, four swing drives, and carbody.

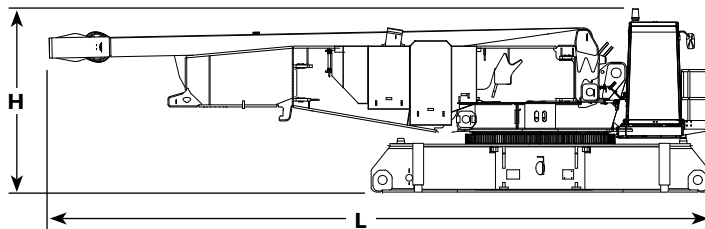

Rotating bed and carbody assembly (decked version)

Length	6,78 m
Width	3,00 m
Height	3,20 m
Weight	64 982 kg

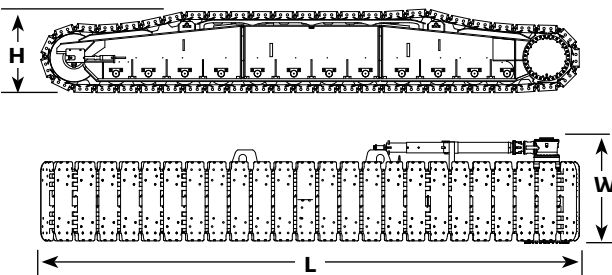

Crawlers

Length	10,43 m
Width	2,03 m
Height	1,61 m
Weight	32 665 kg

Outline dimensions

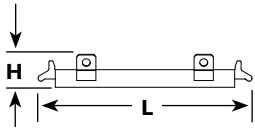

Upper counterweight

Series 1	x 10
Series 2	x 14
Series 3	x 16

Length	2,54 m
Width	2,61 m
Height	0,41 m
Weight	8164 kg

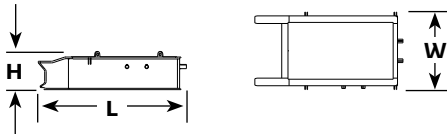

Carbody center counterweight

Series 2	x 2
Series 3	x 2

Length	3,45 m
Width	1,80 m
Height	0,89 m
Weight	13 607 kg

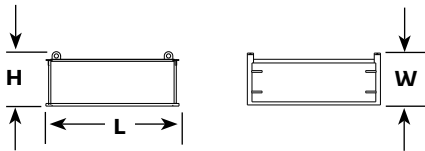

Carbody side counterweight

Series 3	x 4
----------	-----

Length	2,18 m
Width	0,86 m
Height	0,89 m
Weight	6 803 kg

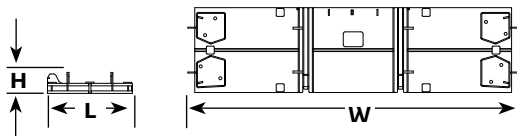

Upper counterweight tray

Length	2,14 m
Width	8,33 m
Height	0,53 m
Weight	19 958 kg

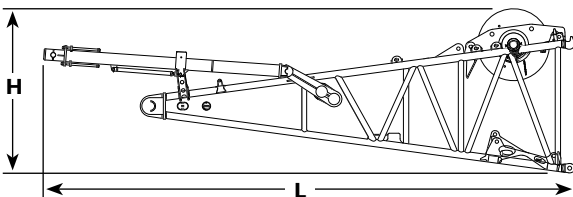

No. 58 Boom butt, drum 1, luffing drum, wire rope

Length	10,13 m
Width	2,96 m
Height	3,10 m
Weight	21 609 kg

Outline dimensions

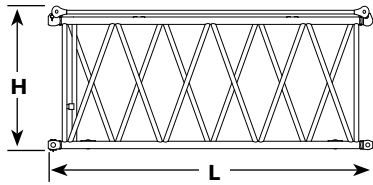

6,0 m No. 58 boom insert and straps

Length	6,19 m
Width	2,96 m
Height	2,67 m
Weight	2 562 kg

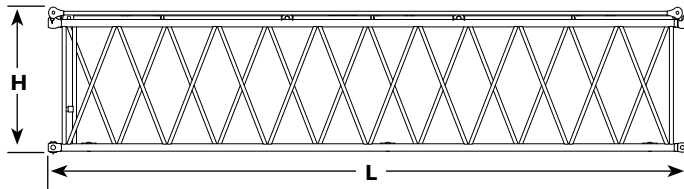

12,0 m No. 58 boom insert and straps

Length	12,19 m
Width	2,96 m
Height	2,65 m
Weight	4 236 kg

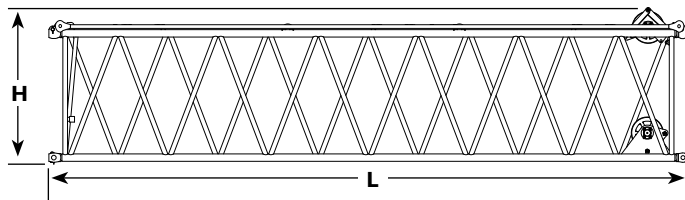

12,0 m No. 58 heavy boom insert with sheave

Length	12,19 m
Width	2,96 m
Height	2,67 m
Weight	5 595 kg

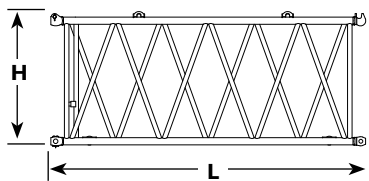

6,0 m No. 58 WA boom insert and straps

Length	6,19 m
Width	2,96 m
Height	2,67 m
Weight	2 690 kg

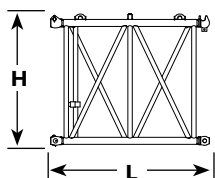

3,0 m No. 58 WA boom insert and straps

Length	3,19 m
Width	2,96 m
Height	2,67 m
Weight	1 599 kg

Outline dimensions

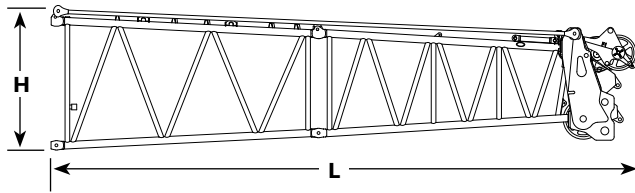

5,0 m No. 58 boom top with 5,0 m transitional insert and straps

Length	11,41 m
Width	2,96 m
Height	2,67 m
Weight	11 373 kg

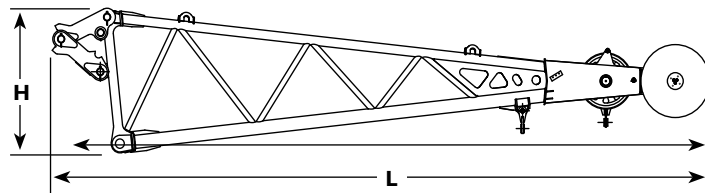

7,0 m No. 58 extended upper boom point

Length	9,52 m
Width	2,60 m
Height	1,99 m
Weight	3 674 kg

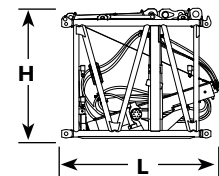

3,0 m No. 58 boom insert with BRS cylinder and straps

Length	3,40 m
Width	2,96 m
Height	2,78 m
Weight	5 488 kg

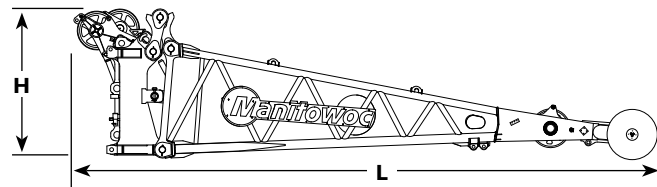

No. 58 WA boom cap and No. 58 WA extended upper boom point

Length	11,50 m
Width	2,70 m
Height	2,97 m
Weight	8 519 kg

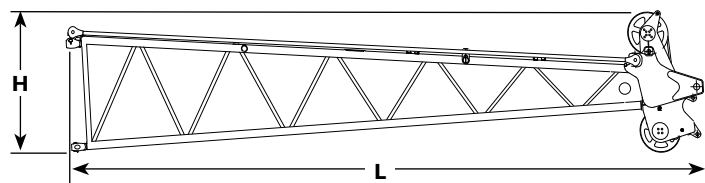

11,0 m No. 59 luffing jib top

Length	11,95 m
Width	2,69 m
Height	2,54 m
Weight	6 015 kg

Outline dimensions

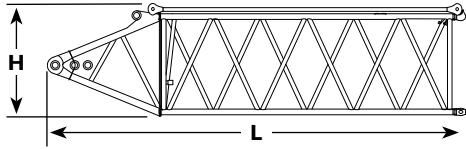

7,0 m No. 59 luffing jib butt

Length	7,15 m
Width	2,69 m
Height	2,17 m
Weight	2 722 kg

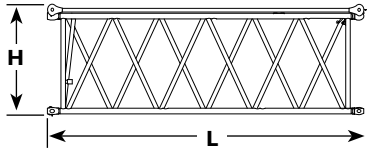

6,0 m No. 59 luffing jib insert

Length	6,19 m
Width	2,69 m
Height	2,17 m
Weight	1 685 kg

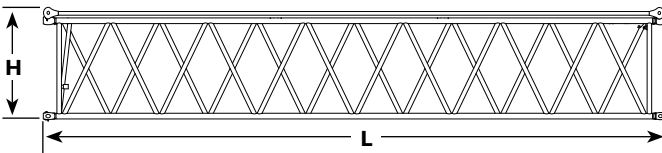

12,0 m No. 59 luffing jib insert

Length	12,19 m
Width	2,69 m
Height	2,17 m
Weight	2 928 kg

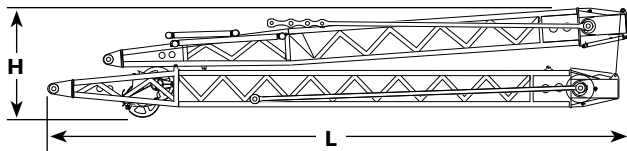

11,5 m No. 59 luffing jib strut with point sheaves and straps

Length	12,46 m
Width	2,69 m
Height	2,27 m
Weight	9 287 kg

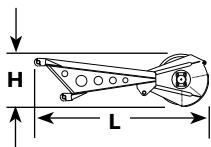

11,5 m No. 59 luffing jib upper point roller assembly

Length	2,64 m
Width	0,41 m
Height	0,81 m
Weight	460 kg

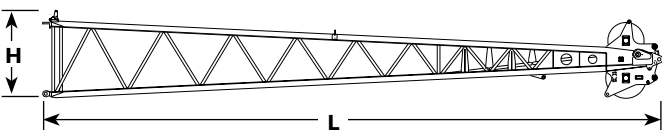

12,2 m No. 133A fixed jib top

Length	13,06 m
Width	2,08 m
Height	1,65 m
Weight	3 649 kg

Outline dimensions

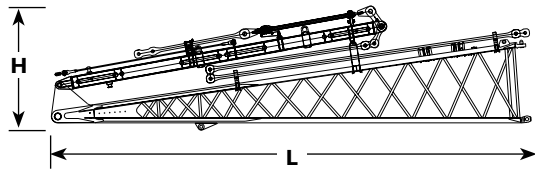

9,1 m No. 133A fixed jib butt with struts

Length	9,38 m
Width	2,07 m
Height	2,42 m
Weight	4 607 kg

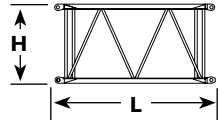

3,0 m No. 133A fixed jib insert

Length	3,18 m
Width	2,07 m
Height	1,65 m
Weight	559 kg

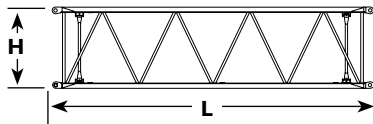

6,1 m No. 133A fixed jib insert

Length	6,22 m
Width	2,07 m
Height	1,65 m
Weight	960 kg

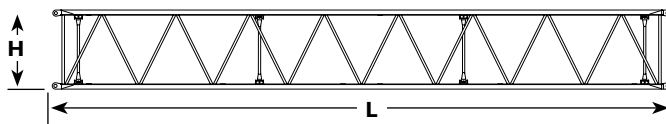

12,2 m No. 133A fixed jib insert

Length	12,32 m
Width	2,07 m
Height	1,65 m
Weight	1 712 kg

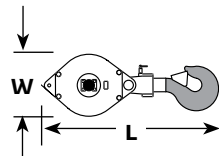

Hook block for 28 mm wire rope

Capacity	410 mt	Length	3,37 m
Weight	9 661 kg	Width	1,19 m

Capacity	317 mt	Length	2,63 m
Weight	7 892 kg	Width	1,15 m

Capacity	227 mt	Length	2,72 m
Weight	5 257 kg	Width	0,93 m

Capacity	182 mt	Length	2,65 m
Weight	4 308 kg	Width	0,87 m

Capacity	100 mt	Length	2,28 m
Weight	3 404 kg	Width	0,86 m

Capacity	41 mt*	Length	1,90 m
Weight	1 179 kg	Width	0,91 m

*Assembly block

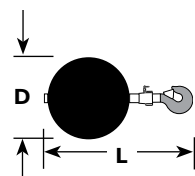

Weight ball

Capacity/Swivel	18 mt	Diameter	0,47 m
Weight	771 kg	Length	1,23 m

Transport data

Load summary																						
Item	Weight each item kg	107 m No. 58WA boom with BRS + 7 m No. 58 extended upper boom point																				
		Quantity on trailer load # (Does not include blocking, strapping, etc.)																				
		1	2	3	4	5	6	7	8	9	10	11	12	13	14	15	16	17	18	19	20	21
Upperworks module	39 612	1																				
Carbody and adapter	28 161		1																			
Crawler assembly	32 665			1	1																	
Counterweight tray	19 958																	1				1
Upper counterweight (box)	8 164					1		1	1	2	1	2	1	1	2	1	2					
Carbody center counterweight	13 607																		1	1		
Carbody side counterweight	6 803							1	1										1	1		
Auxiliary counterweight tray	2 903																					1
Auxiliary counterweight (box)	7 938																				1	
8,0 m No. 58 boom butt, drum 1 w/ wire rope	21 609						1															
5,0 m No. 58 boom top and straps	9 169					1																
5,0 m No. 58 boom trans. insert and straps	2 204					1																
6,0 m No. 58 boom insert and straps	2 562														1							
12,0m No. 58 boom with WRG Boom insert and straps	5 595							1														
12,0m No. 58 boom insert and straps	4 236								1	1	1	1	1	1								
3,0 m No. 58 boom insert with BRS cylinder and straps	5 448																				1	
BRS A-frame and intermediate suspension	680																					1
No. 58WA boom cap and No. 58 WA extended upper boom point	3 674															1						
180 t 5 sheave load block	4 309										1											
100 t 3 sheave load block	3 402														1							
Reel cable - 701 m	3 629												1									
Miscellaneous	907																1					
Payload for each trailer m		39 612	28 161	32 665	32 665	19 538	21 609	20 562	19 203	20 564	16 705	20 564	16 029	15 802	18 890	11 683	18 414	19 958	20 410	20 410	13 380	19 684

Crane assembly - undecked

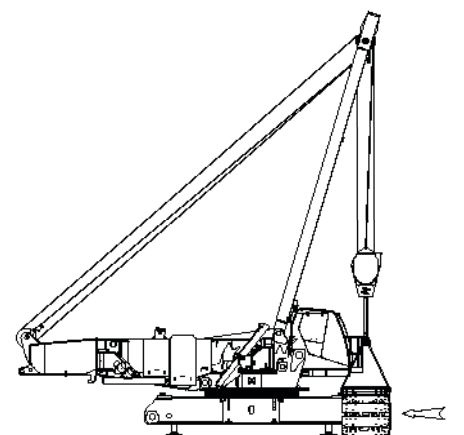
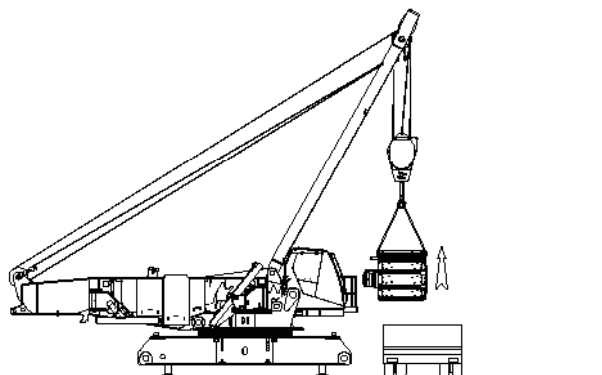
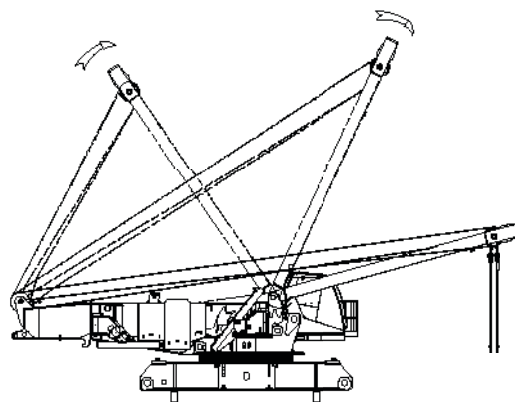
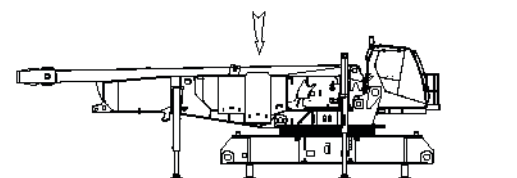
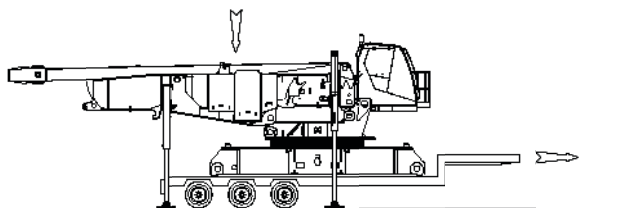
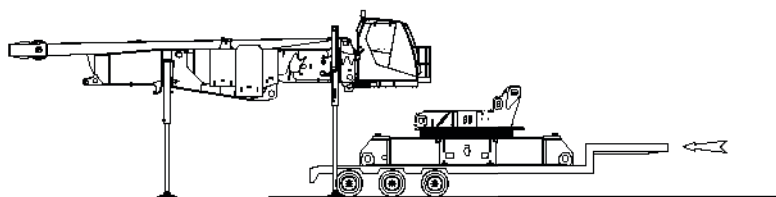
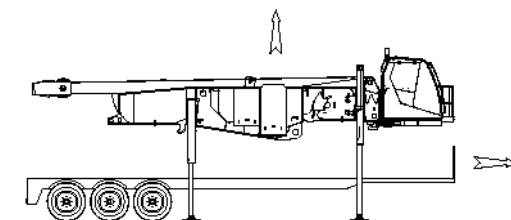
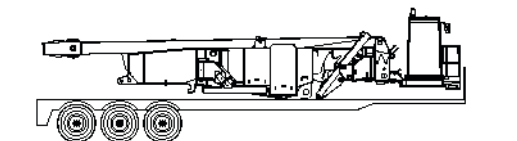

Crane assembly - undecked

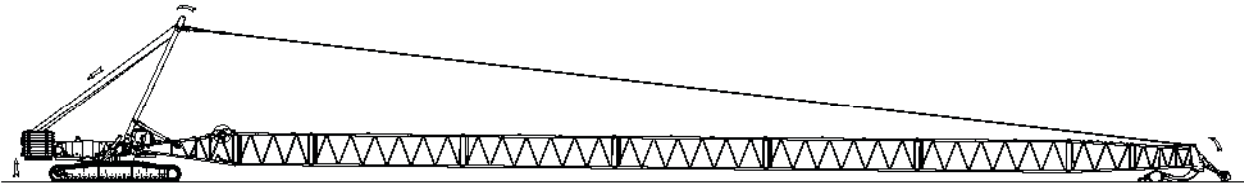
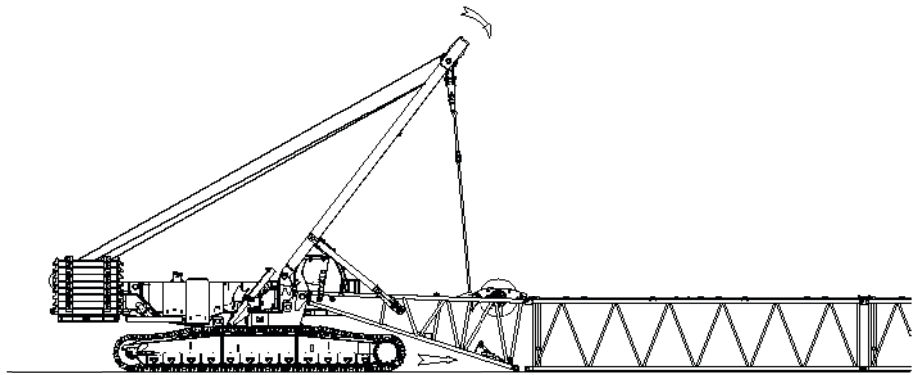
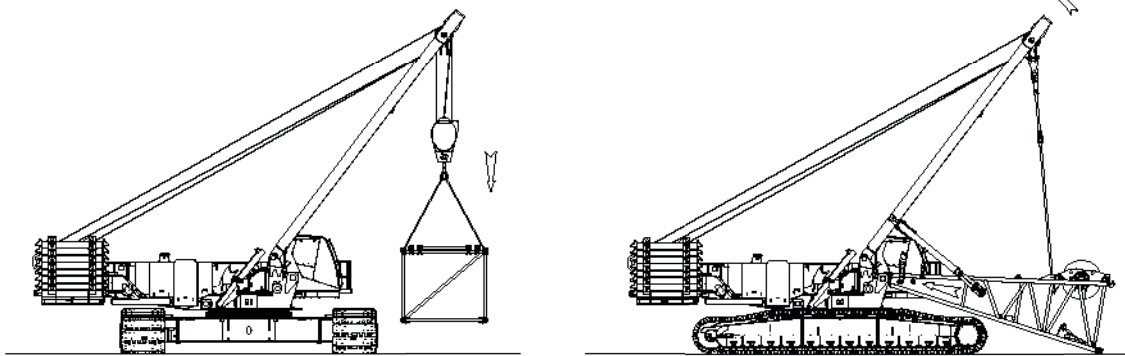
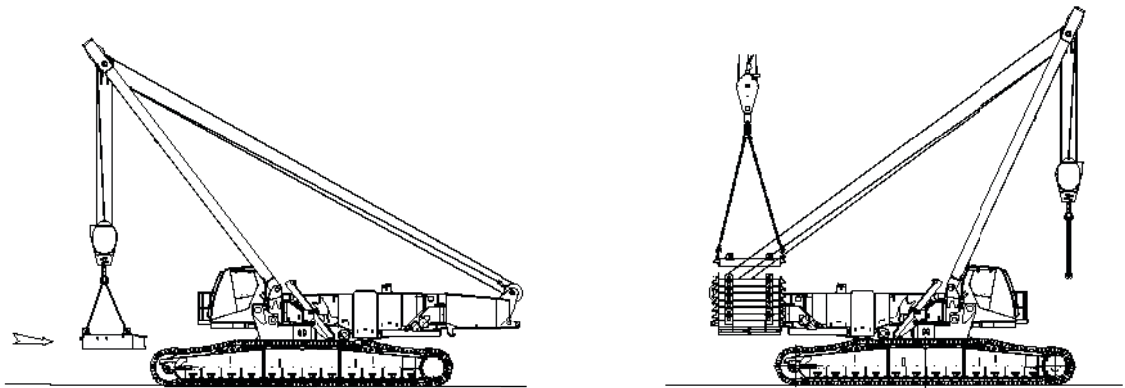

Crane assembly - decked

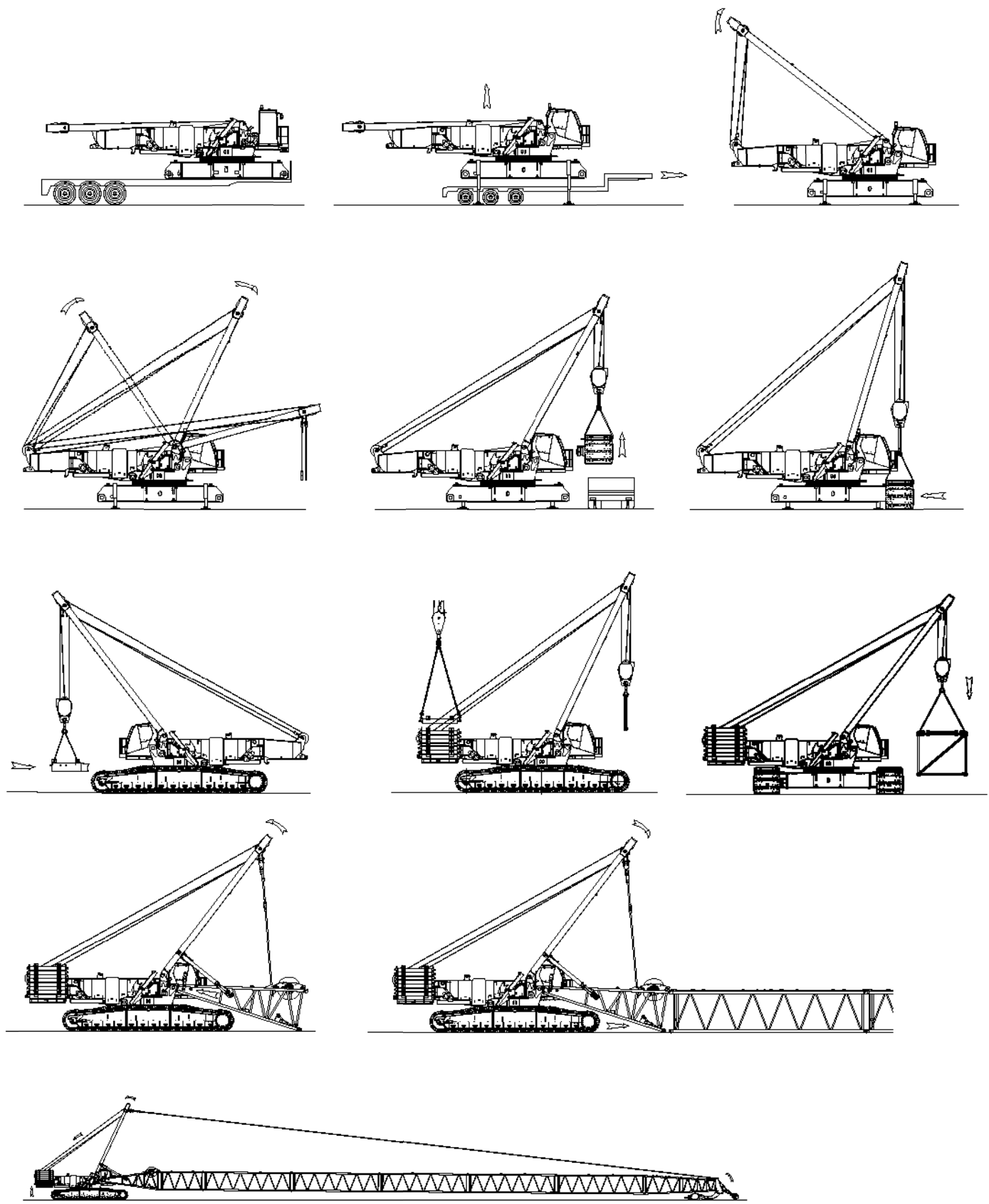

Performance data

Main hoist 28 mm wire rope Single line speed in m per minute

Single line pull kg	Layer										
	1 335 mm	2 363 mm	3 391 mm	4 419 mm	5 447 mm	6 475 mm	7 503 mm	8 531 mm	9 559 mm	10 587 mm	11 615 mm
0	105	114	123	132	140	149	158	167	176	184	193
2 268	105	114	123	132	140	149	158	167	176	184	193
4 536	105	114	123	131	139	147	154	162	169	176	183
6 804	103	110	117	124	131	135	136	137	138	139	141
9 072	98	101	102	104	105	106	107	108	109	111	112
11 340	83	84	85	87	87	89	90	91	92	94	95
13 608	71	73	74	75	76	77	78	80	81	82	83
16 239	62	63	65	66	67	68	69	70	72	73	74

Whip drum 28 mm wire rope Single line speed in m per minute

Single line pull kg	Layer						
	1 335 mm	2 363 mm	3 391 mm	4 419 mm	5 447 mm	6 475 mm	7 503 mm
0	85	92	99	106	113	120	127
2 268	80	86	92	98	105	111	116
4 536	75	81	86	91	96	101	101
6 804	68	69	69	70	71	72	73
9 072	53	54	55	56	57	58	59
11 340	45	45	46	47	48	49	50
13 608	39	40	41	41	42	43	44

Performance data

Optional high speed whip 28 mm wire rope single line speed in m per minute							
Single line pull kg	Layer						
	1 335 mm	2 363 mm	3 391 mm	4 419 mm	5 447 mm	6 475 mm	7 503 mm
0	105	114	123	132	140	149	158
2 268	105	114	123	132	140	149	158
4 536	105	114	123	131	139	147	154
6 804	103	110	117	124	131	135	136
9 072	98	101	102	104	105	106	107
11 340	83	84	85	87	87	89	90
13 608	71	73	74	75	76	77	78

No. 58 HL boom 28 mm hoist line				
Boom length m	Whip line - drum 2 or 3		Hoist line - drum 1	
	1 Part m	2 Part m	m	Maximum parts of line for full hoisting range
30,0	79	116	838	26
36,0	91	134	853	22
42,0	104	152	853	18
48,0	116	171	930	18
54,0	128	186	930	14
60,0	140	204	930	14
66,0	152	223	930	12
72,0	165	241	930	10
78,0	177	259	930	10
84,0	189	277	930	8
90,0	201	296	930	6
96,0	213	314	930	6

No. 58 HL boom Main load block reeving 28 mm wire rope	
No. parts of line	Maximum load kg
2	32 520
4	65 090
6	97 610
8	130 180
10	162 750
12	195 270
14	227 840
16	260 360
18	292 930
20	322 690
22	351 530
24	379 840
26	400 000

NOTE: Hoist and whip line lengths given in table will allow hook to touch ground. When block travel below ground is required, add additional rope equal to parts of line times added travel distance. Hoisting distance or line pull may be limited when block travel below ground is required.

Performance data

No. 58 HL boom with 7 m extended upper boom point 28 mm wire rope			
Boom length m	Whip line drum 2 or 3	Hoist line drum 1	
	1 Part m	m	Total parts of line
66,0	168	533	6
72,0	180	579	6
78,0	192	610	6
84,0	204	655	6
90,0	216	701	6

NOTE: Hoist and whip line lengths given in table will allow hook to touch ground. When block travel below ground is required, add additional rope equal to parts of line times added travel distance. Hoisting distance or line pull may be limited when block travel below ground is required.

No. 58 HL boom with 7 m extended upper boom point Main load block reeving 28 mm wire rope	
No. parts of line	Maximum load kg
2	32 520
4	65 090
6	97 600

No. 58 HL boom with 7 m extended upper boom point and 30 m No. 59A mast 28 mm wire rope			
Boom length m (ft)	Whip line drum 2 or 3	Hoist line drum 1	
	1 Part m	m	Total parts of line
96,0 (315.0)	229	747	6

NOTE: Hoist and whip line lengths given in table will allow hook to touch ground. When block travel below ground is required, add additional rope equal to parts of line times added travel distance. Hoisting distance or line pull may be limited when block travel below ground is required.

No. 58 HL boom with 7 m extended upper boom point and No. 59A 30 m mast 28 mm wire rope	
No. parts of line	Maximum load kg
2	32 520
4	65 090
6	81 500

No. 58 WA boom with 7.6 m extended upper boom point 28 mm wire rope				
Boom length m	Whip line - drum 2 or 3		Hoist line - drum 1	
	1 Part m	2 Part m	m	Total parts of line
65	183	244	686	8
68	183	259	701	8
71	183	274	732	8
74	198	274	762	8
77	198	290	792	8
80	198	290	808	8
83	213	305	838	8
86	213	320	869	8
89	229	320	899	8
92	-	-	914	8

No. 58 WA boom with 7.6 m extended upper boom point Main load block reeving 28 mm wire rope	
No. parts of line	Maximum load kg
2	32 520
4	65 090
6	97 610
8	130 000

Performance data

No. 59 luffing jib on No. 58 HL boom 28 mm hoist line			
Boom length m	Hoist line drum 1 m	Whip line drum 2	
		1 Part m	2 Part m
30,0	747	244	366
36,0	808	259	381
42,0	808	274	396
48,0	823	290	427
54,0	823	305	442
60,0	823	305	442
66,0	823	305	422

No. 59 luffing jib on No. 58 HL boom Main load block reeving 28 mm hoist line	
No. parts of line	Maximum load kg
2	32 520
4	65 090
6	97 610
8	130 180
10	162 750
12	185 200

NOTE: Hoist line lengths given in table include all luffing jib lengths. Hoist and whip line lengths given in table will allow hook to touch ground. When block travel below ground is required, add additional rope equal to parts of line times added travel distance. Hoisting distance or line pull may be limited when block travel below ground is required.

No. 133A fixed jib on No. 58 HL boom 28 mm hoist line		
m	Hoist line drum 1 m	Hoist line drum 2 m
42,0	535	475
48,0	565	475
54,0	610	475
60,0	660	475
66,0	670	475
72,0	705	475

No. 133A luffing jib on No. 58 HL boom Main load block reeving 28 mm hoist line	
No. parts of line	Maximum load kg
2	32 520
4	65 090
6	93 300

NOTE: Hoist line lengths given in table include all luffing jib lengths. Hoist and whip line lengths given in table will allow hook to touch ground. When block travel below ground is required, add additional rope equal to parts of line times added travel distance. Hoisting distance or line pull may be limited when block travel below ground is required.

Performance data

MAX-ER No. 58 HL boom 28 mm wire rope				
Boom length m	Whip line - drum 2 or 3		Hoist line - drum 1	
	1 Part m	2 Part m	m	Total parts of line
42,0	107	152	1 082	24
48,0	119	171	1 128	22
54,0	131	189	1 158	20
60,0	143	207	1 158	18
66,0	155	226	1 158	16
72,0	168	244	1 158	14
78,0	177	262	1 189	14
84,0	189	277	1 189	12
90,0	201	296	1 189	10
96,0	213	314	1 189	8
102,0	226	332	1 189	8
108,0	238	351	1 189	6
114,0	250	369	1 189	6
120,0	262	387	1 189	6

MAX-ER No. 58 HL boom Main load block reeving 28 mm wire rope	
No. parts of line	Maximum load kg
2	32 520
4	65 090
6	97 610
8	130 180
10	162 750
12	195 270
14	227 840
16	260 360
18	292 930
20	322 690
22	351 530
24	379 800

NOTE: Hoist and whip line lengths given in table will allow hook to touch ground. When block travel below ground is required, add additional rope equal to parts of line times added travel distance. Hoisting distance or line pull may be limited when block travel below ground is required.

Boom combinations

No. 58 HL boom combinations

Boom length m	Boom inserts length m			
	5,0*	6,0	12,0	12,0**
30	1	0	0	1
36	1	1	0	1
42	1	0	1	1
48	1	1	1	1
54	1	0	2	1
60	1	1	2	1
66	1	0	3	1
72	1	1	3	1
78	1	0	4	1
84	1	1	4	1
90	1	0	5	1
96	1	1	5	1

*transition boom insert.
**with auxiliary sheave insert.

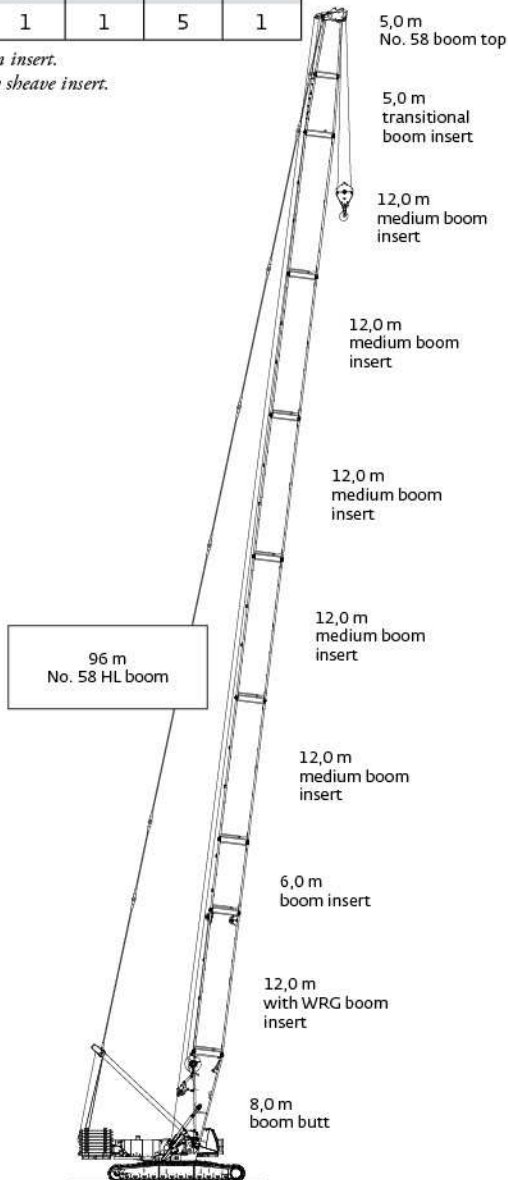

No. 58 HL boom with 7 m extended upper boom point combinations

Boom length m	Boom inserts length m			
	5,0*	6,0	12,0	12,0**
30	1	0	0	1
36	1	1	0	1
42	1	0	1	1
48	1	1	1	1
54	1	0	2	1
60	1	1	2	1
66	1	0	3	1
72	1	1	3	1
78	1	0	4	1
84	1	1	4	1
90	1	0	5	1

*transition boom insert.
**with auxiliary sheave insert.

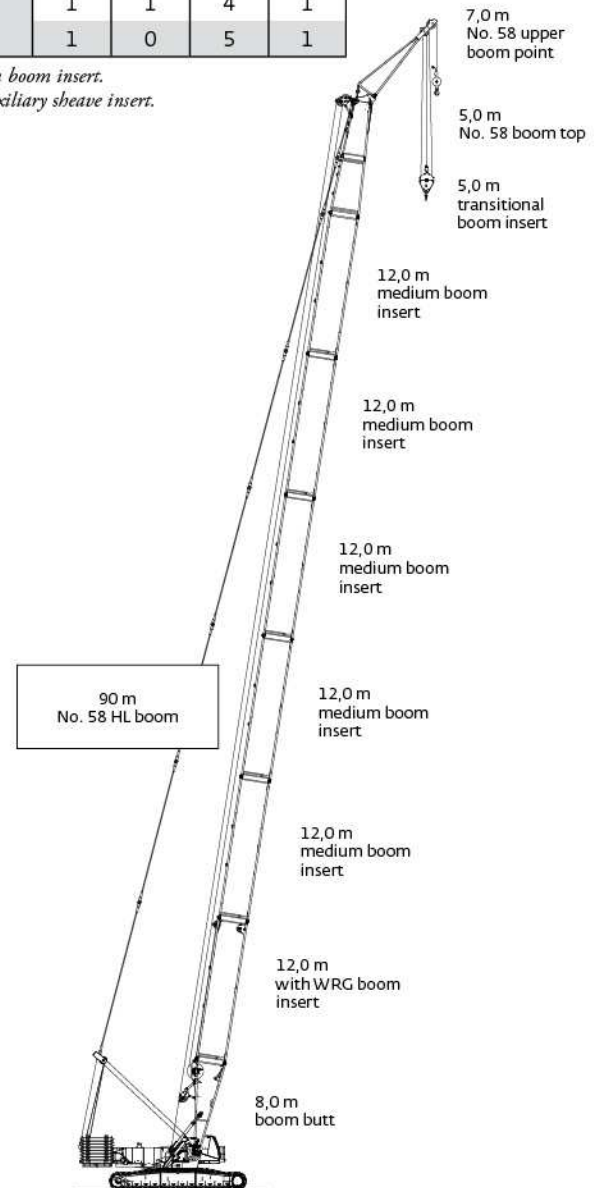

Boom combinations

No. 58 WA boom combinations with 7,6 m extended upper boom point

Boom length m	Boom inserts length m				
	5,0*	6,0	12,0	12,0	12,0**
65	1	1	0	3	1
68	1	0	1	3	1
71	1	1	0	3	1
74	1	0	1	4	1
77	1	1	0	4	1
80	1	0	1	4	1
83	1	1	0	4	1
86	1	0	1	5	1
89	1	1	0	5	1
92	1	0	1	5	1

*transition boom insert.
**with auxiliary sheave insert.

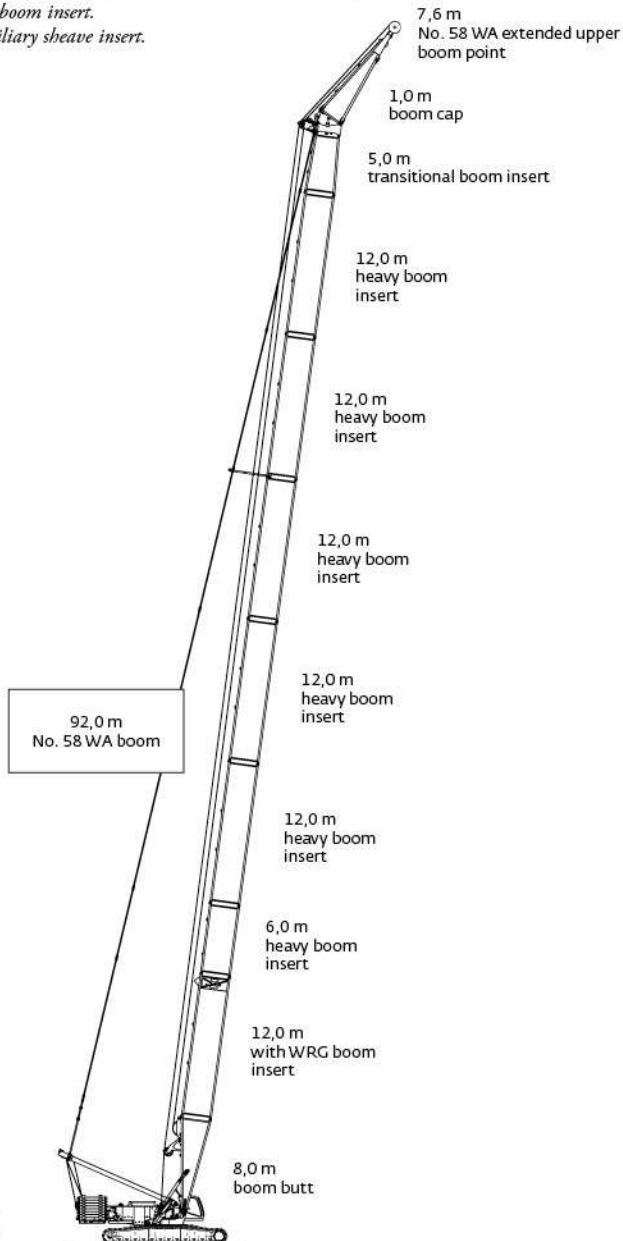

No. 58 WA boom with BRS combinations with 7,6 m extended upper boom point

Boom length m	Boom inserts length m						
	5,0*	3,0	3,0***	6,0	12,0	12,0	12,0**
89	1	0	1	0	5	0	1
92	1	1	1	0	5	0	1
95	1	0	1	1	5	0	1
98	1	1	1	1	5	0	1
101	1	0	1	0	5	1	1
104	1	1	1	0	4	2	1
107	1	0	1	1	4	2	1

*transition boom insert.
**with auxiliary sheave insert.
***with BRS cylinder insert.

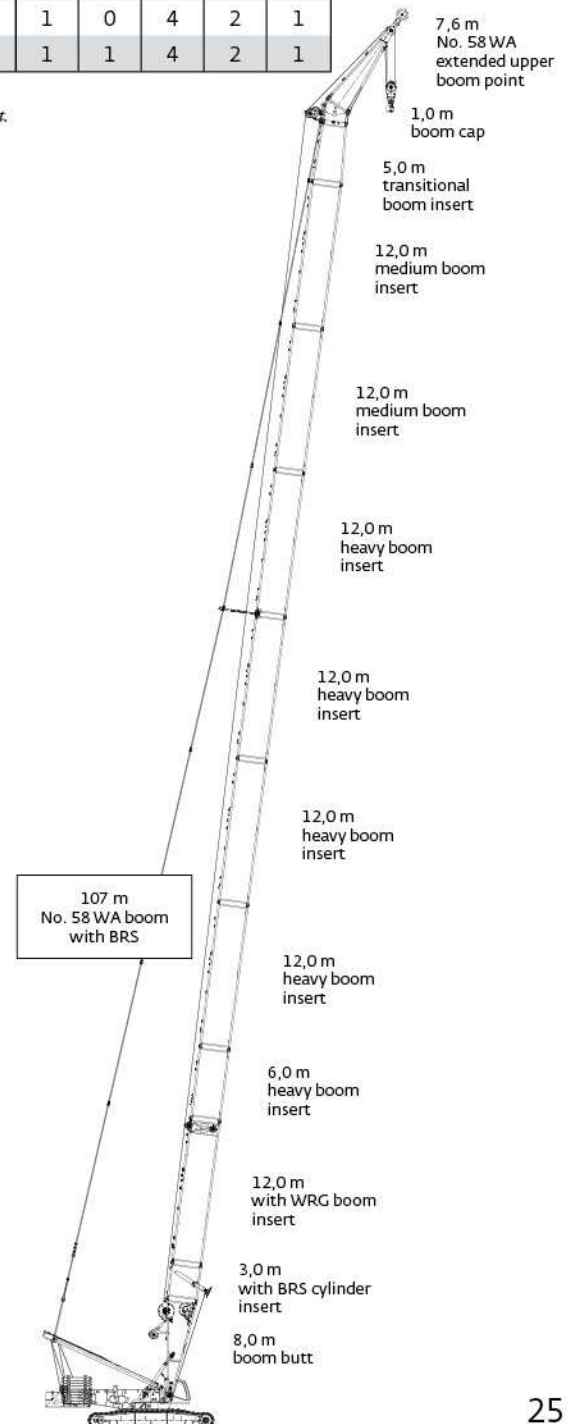

Boom combinations

No. 133A fixed jib combinations			
Fixed jib length m	Fixed jib inserts length m		
	3,1	6,0	12,2
21,3	0	0	0
24,4	1	0	0
27,4	0	1	0
30,5	1	1	0
33,5	0	0	1
36,6	1	0	1
39,6	0	1	1
42,7	1	1	1

No. 59 luffing jib combinations		
Luffing jib length m	Luffing jib inserts length m	
	6,0	12,0
24	1	0
30	0	1
36	1	1
42	0	2
48	1	2
54	0	3
60	1	3
66	0	4
72	1	4
78	0	5
84	1	5

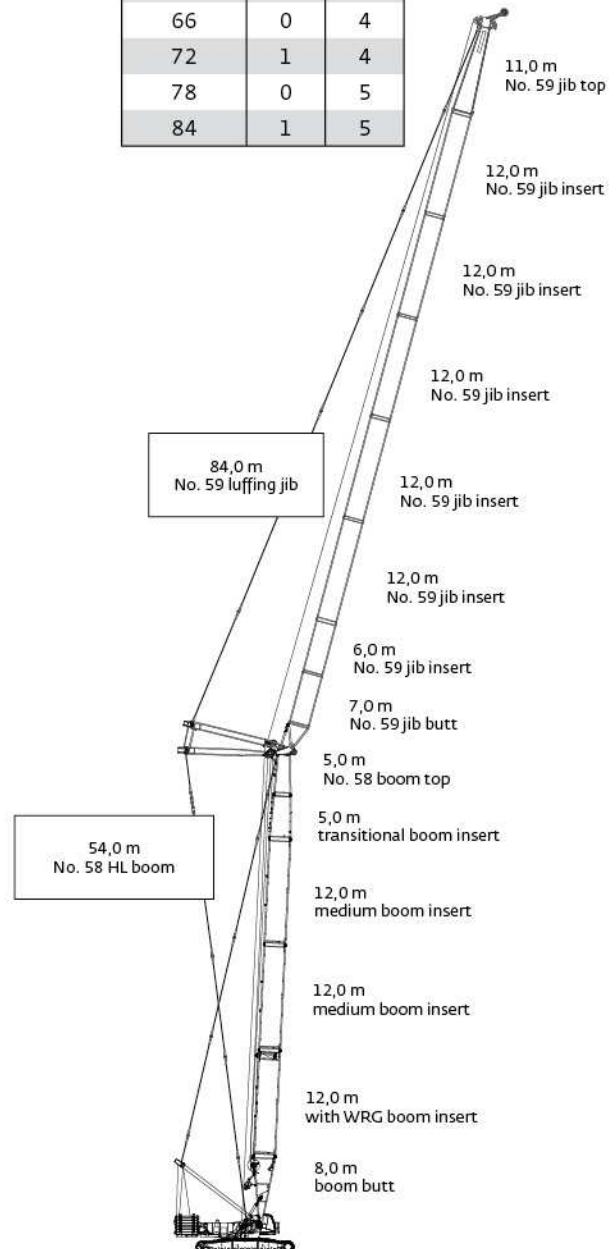
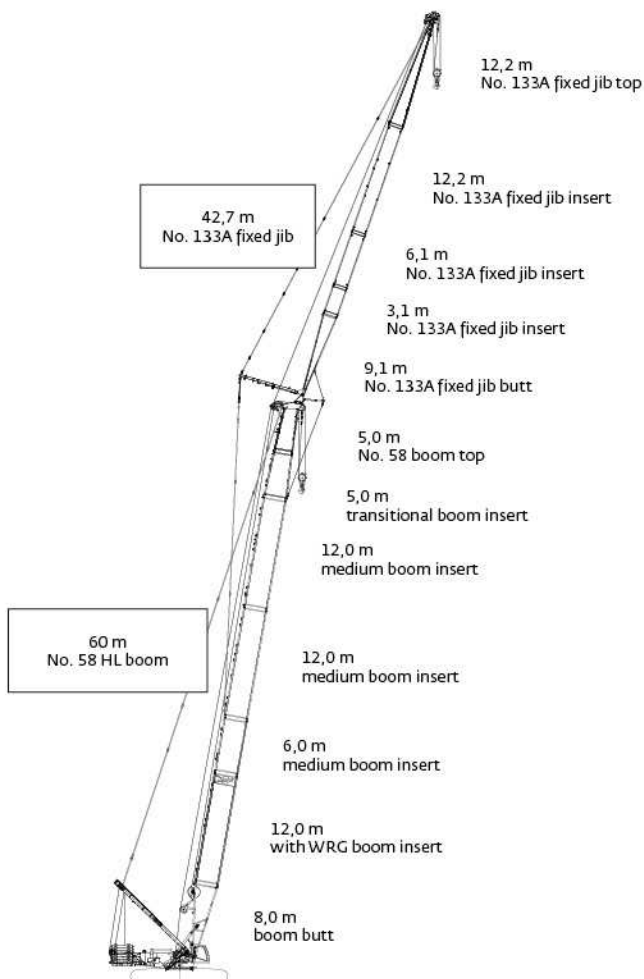

Boom range diagram

No. 58 HL boom

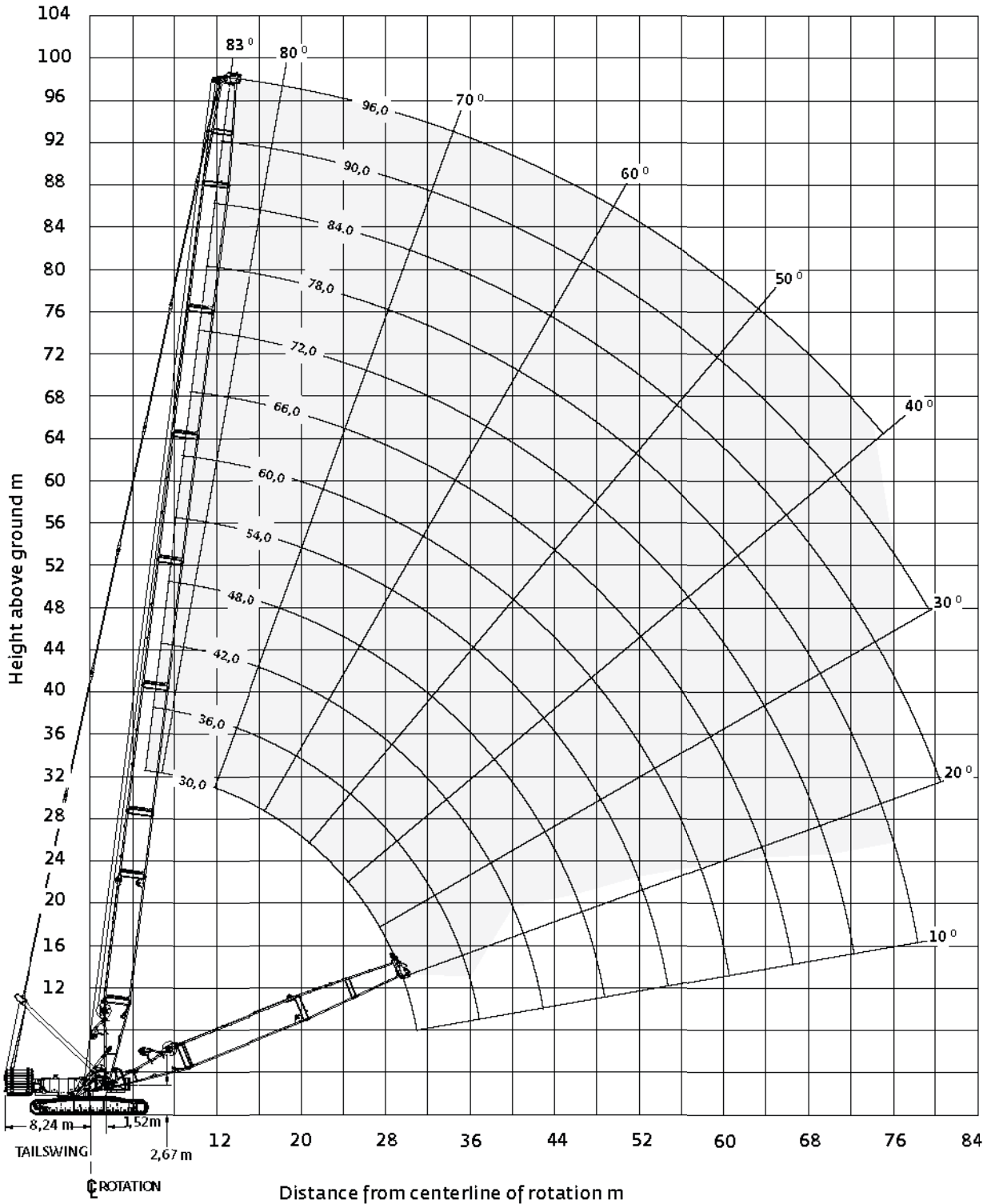

Boom load charts

360° Rating, kg x 1 000

No. 58 HL boom												
Radius m	150 590 kg Counterweight						54 430 kg Carbody counterweight					
	Boom length m											
	30,0	36,0	42,0	48,0	54,0	60,0	66,0	72,0	78,0	84,0	90,0	96,0
6,4	400,0											
8,0	323,8	323,3	283,4									
10,0	256,4	256,1	256,6	257,2	216,1							
12,0	194,8	195,1	195,5	195,4	193,2	181,9	159,6	147,0				
14,0	153,7	153,9	154,2	154,1	154,0	154,5	145,6	134,0	129,7	113,7	95,5	
18,0	106,3	106,4	106,6	106,3	106,2	105,8	105,5	105,7	105,4	103,4	89,4	77,2
22,0	79,6	79,7	79,9	79,5	79,4	78,9	78,5	78,0	77,6	77,0	76,8	72,5
26,0	62,4	62,5	62,7	62,4	62,1	61,6	61,3	60,7	60,2	59,6	59,0	58,4
30,0	50,3	50,5	50,7	50,3	50,1	49,6	49,2	48,6	48,1	47,5	46,9	46,2
34,0		41,6	41,9	41,5	41,3	40,8	40,3	39,8	39,2	38,5	38,0	37,3
38,0			35,0	34,7	34,5	33,9	33,6	32,9	32,4	31,7	31,1	30,4
40,0			32,1	31,9	31,7	31,1	30,7	30,1	29,5	28,8	28,3	27,6
44,0				27,0	26,8	26,2	25,9	25,2	24,7	24,0	23,4	22,7
48,0					22,8	22,3	21,9	21,2	20,7	20,0	19,4	18,7
52,0					19,4	18,9	18,5	17,9	17,4	16,6	16,1	15,3
56,0						16,1	15,7	15,1	14,5	13,8	13,3	12,5
60,0							13,3	12,6	12,1	11,4	10,8	10,1
64,0								11,1	10,5	10,0	9,3	8,7
68,0									8,6	8,1	7,4	6,8
70,0									7,7	7,2	6,5	6,0
76,0										4,9	4,2	3,7

For complete chart, refer to www.cranelibrary.com.

Extended upper boom point range diagram

No. 58 HL boom with 7 m extended upper boom point

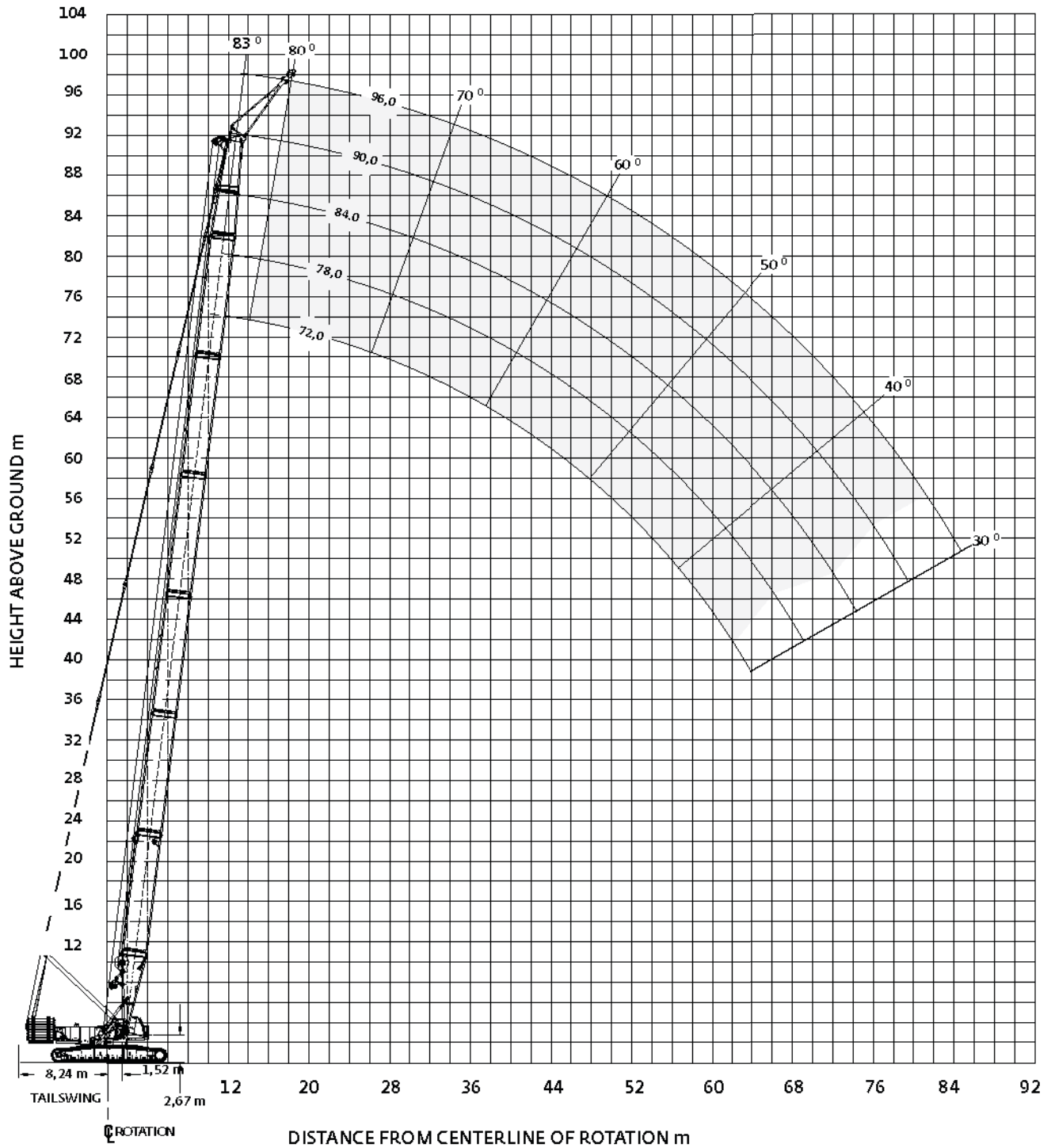

Extended upper boom point load charts

360° Rating, kg x 1 000

No. 58 HL boom with 7 m extended upper boom point					
Radius m	150 590 kg Counterweight 54 430 kg Carbody counterweight				
	Boom length m				
	66,0	72,0	78,0	84,0	90,0
15,2	97,6				
16,8	97,6	97,6	91,3	87,8	
18,0	97,6	97,6	89,6	86,5	
20,0	95,5	95,1	87,1	84,4	74,6
22,0	82,7	82,3	82,7	81,1	72,5
24,0	72,9	72,4	72,0	71,8	70,1
26,0	64,8	64,4	63,9	63,4	63,0
28,0	58,1	57,6	57,1	56,6	56,1
30,0	52,4	51,9	51,4	50,8	50,3
32,0	45,5	47,0	46,5	45,9	45,4
34,0	43,3	42,7	42,2	41,6	41,1
38,0	36,2	35,6	35,1	34,5	33,9
40,0	33,3	32,7	32,2	31,5	31,0
44,0	28,3	27,7	27,1	26,5	25,9
48,0	24,2	23,5	23,0	22,3	21,8
52,0	20,7	20,1	19,5	18,9	18,3
56,0	17,8	17,1	16,6	15,9	15,4
60,0	15,2	14,6	14,0	13,4	12,8
64,0		12,4	11,8	11,2	10,6
68,0			9,9	9,2	8,7
72,0			8,1	7,5	7,0
76,0				5,9	5,4
82,0					3,4

For complete chart, refer to www.cranelibrary.com.

Wind Attachment range diagram

No. 58 WA with 7,6 m extended upper boom point

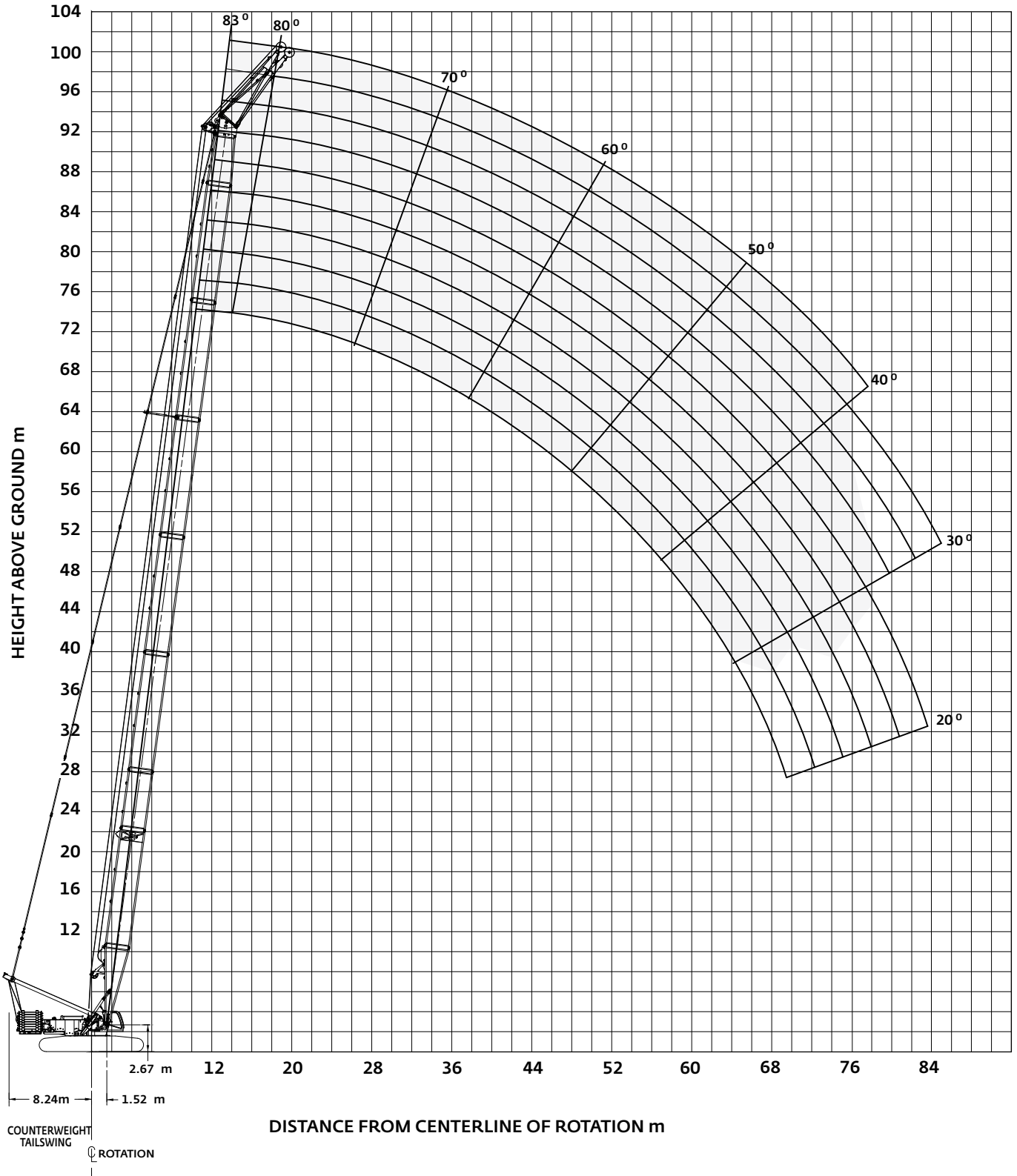

Wind Attachment load charts

360° Rating, kg x 1 000

No. 58 WA with 7,6 m extended upper boom point													
166 920 kg Counterweight 54 430 kg Carbody counterweight													
Radius m	28° offset Boom length m						35° offset Boom length m						
	65,0	71,0	77,0	83,0	89,0	92,0	Radius m	65,0	71,0	77,0	83,0	89,0	92,0
15,2	130.0	130.0					15,2	130.0					
18,0	118.5	118.1	117.8	117.5	86.5	108.5	18,0	119.9	118.7	118.4	87.8	87.3	87.1
22,0	88.7	88.0	87.5	87.0	75.8	86.3	22,0	89.3	88.7	88.3	77.0	76.5	76.3
24,0	78.2	77.5	76.9	76.3	59.7	75.6	24,0	78.7	78.1	77.6	60.9	60.3	60.0
28,0	62.3	61.5	61.0	60.3	53.5	59.5	28,0	62.8	62.0	61.5	54.6	54.0	53.7
30,0	56.2	55.4	54.8	54.1	43.5	53.3	30,0	56.6	55.9	55.3	44.6	44.0	43.7
34,0	46.4	45.5	44.9	44.2	39.4	43.3	34,0	46.7	45.9	45.3	40.5	39.9	39.6
36,0	42.3	41.5	40.9	40.1	32.7	39.2	36,0	42.6	41.9	41.3	33.7	33.1	32.7
40,0	35.7	34.8	34.1	33.4	29.8	32.4	40,0	35.9	35.1	34.4	30.8	30.1	29.8
42,0	32.8	31.9	31.3	30.5	24.9	29.6	42,0	33.1	32.2	31.6	25.9	25.2	24.9
46,0	28.0	27.1	26.4	25.6	22.8	24.7	46,0	28.2	27.3	26.7	23.8	23.1	22.7
48,0	25.9	24.9	24.3	23.5	19.1	22.5	48,0	26.1	25.2	24.5	20.0	19.3	18.9
52,0	22.2	21.2	20.6	19.8	14.5	18.8	52,0	22.3	21.4	20.8	15.4	14.7	14.3
58,0	17.6	16.7	16.0	15.2	10.8	14.2	58,0	17.7	16.8	16.2	11.7	10.9	10.6
64,0	13.9	13.0	12.3	11.5	7.8	10.5	64,0		13.1	12.4	8.6	7.9	7.5
70,0			9.3	8.5	5.0	7.5	70,0			9.4	6.0	5.1	4.6
76,0			6.7	5.9		4.6	76,0						

For complete chart, refer to www.cranelibrary.com.

Wind Attachment range diagram with Boom Raising System

No. 58 WA with BRS with 7,6 m extended upper boom point

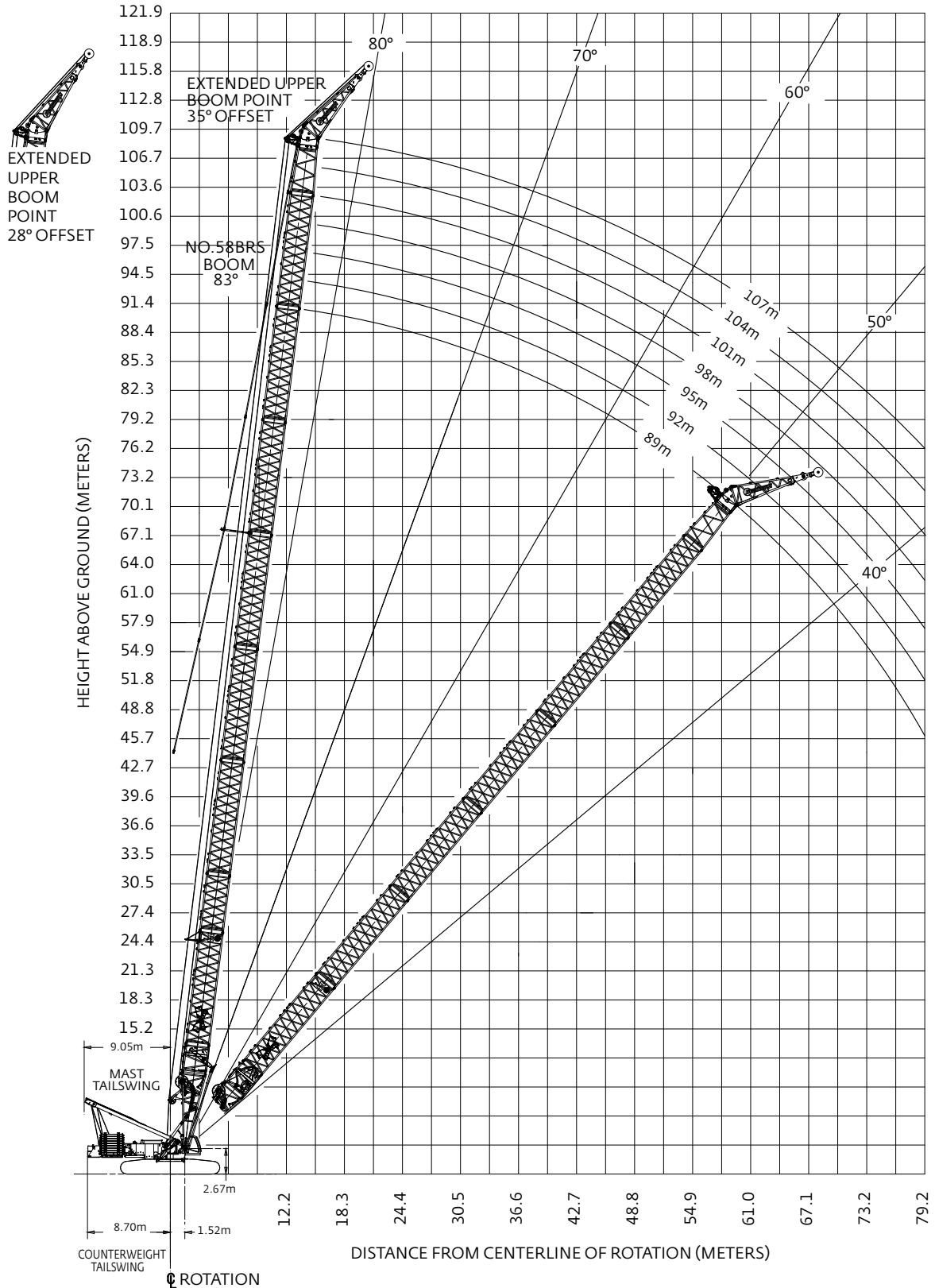

Wind Attachment load charts

with Boom Raising System

360° Rating, kg x 1 000

No. 58 WA with BRS with 7,6 m extended upper boom point

166 920 kg Counterweight
54 430 kg Carbody counterweight
18 730 kg Auxiliary counterweight

Radius m	28° offset Boom length m							35° offset Boom length m							
	89,0	92,0	95,0	98,0	101,0	104,0	107,0	Radius m	89,0	92,0	95,0	98,0	101,0	104,0	107,0
18,3	116,0	108,8	107,0	105,7				18,3	111,9	105,7	101,6				
20,0	106,1	105,4	104,6	103,6	99,3	90,9	87,8	20,0	107,1	105,0	98,3	95,8	92,8	85,8	
22,0	93,9	92,3	91,6	90,6	92,7	88,5	86,6	22,0	94,0	93,2	93,4	92,7	90,4	84,1	82,0
24,0	82,8	81,8	81,2	80,3	81,6	81,8	81,1	24,0	83,4	82,5	82,0	81,0	82,9	81,2	80,1
28,0	66,4	65,5	64,8	64,0	65,0	64,9	64,3	28,0	66,9	66,1	65,5	64,7	65,8	65,6	65,0
30,0	59,7	58,9	58,3	57,5	58,3	58,1	57,6	30,0	60,3	59,5	59,0	58,2	59,0	58,9	58,3
34,0	48,7	48,0	47,4	46,6	47,3	47,2	46,6	34,0	49,3	48,6	48,0	47,2	47,9	47,8	47,2
36,0	44,2	43,5	42,9	42,1	42,8	42,6	42,1	36,0	44,8	44,0	43,4	42,7	43,3	43,2	42,7
40,0	36,6	35,9	35,2	34,5	35,1	35,0	34,4	40,0	37,1	36,3	35,7	35,0	35,6	35,5	34,9
42,0	33,3	32,6	32,0	31,2	31,9	31,7	31,2	42,0	33,8	33,0	32,4	31,7	32,3	32,2	31,7
46,0	27,7	26,9	26,3	25,6	26,2	26,1	25,5	46,0	28,1	27,3	26,8	26,0	26,6	26,5	25,9
48,0	25,2	24,5	23,9	23,1	23,7	23,6	23,0	48,0	25,6	24,8	24,3	23,5	24,1	24,0	23,4
52,0	20,9	20,1	19,5	18,8	19,4	19,3	18,7	52,0	21,2	20,4	19,9	19,1	19,7	19,6	19,0
58,0	15,4	14,7	14,1	13,4	14,0	13,9	13,3	58,0	15,7	15,0	14,4	13,7	14,3	14,2	13,6
64,0	11,0	10,3	9,8	9,0	9,6	9,5	8,9	64,0	11,2	10,5	10,0	9,3	9,8	9,7	9,2
70,0	7,4	6,6	6,1	5,4	5,9	5,8	5,3	70,0	7,5	6,8	6,3	5,5	6,1	6,0	5,5
74,0	5,2	5,6						74,0	5,3						

For complete chart, refer to www.cranelibrary.com.

Fixed jib range diagram

No. 58 HL boom with No. 133A fixed jib

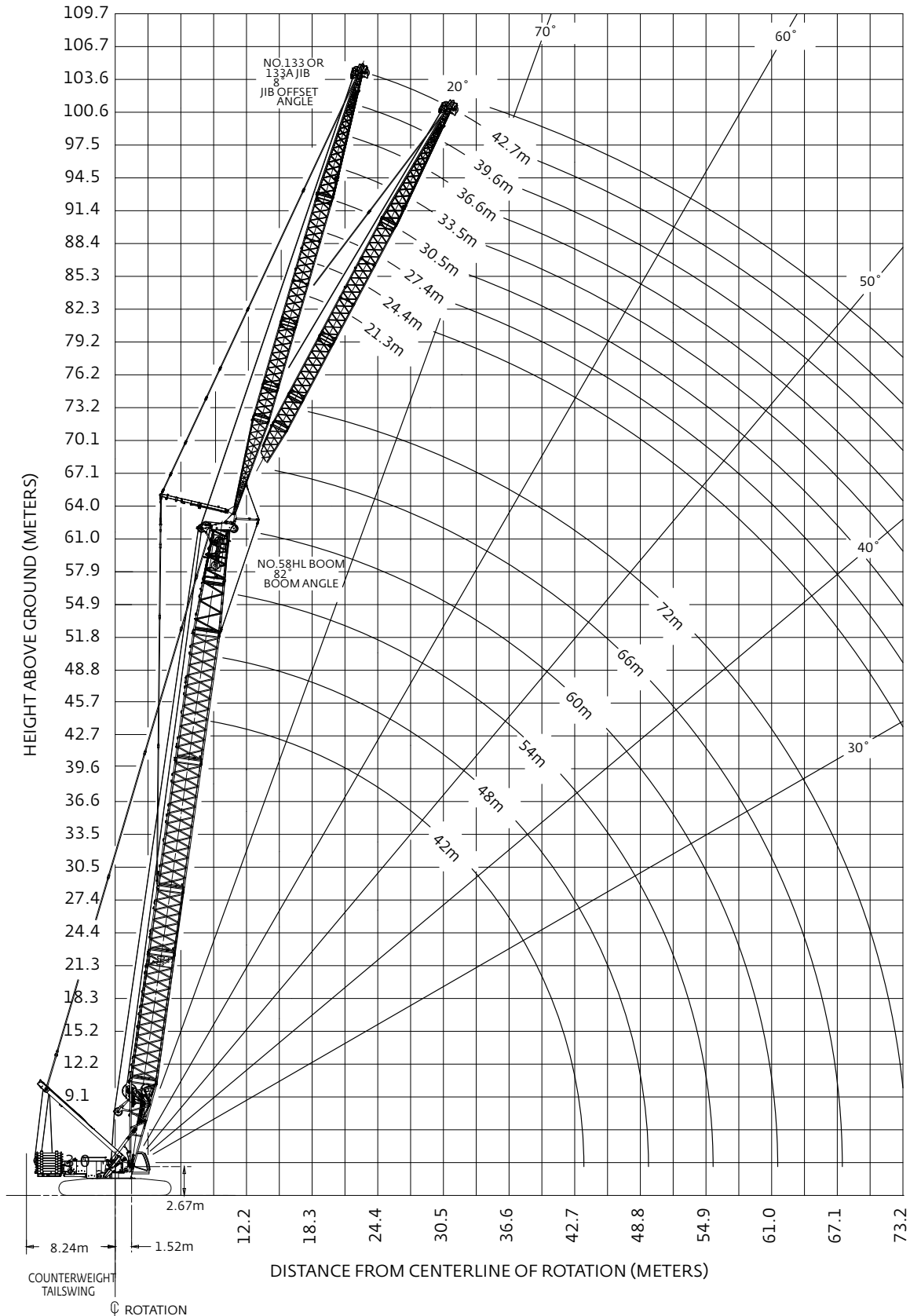

Fixed jib load charts

360° Rating, kg x 1 000

No. 58 HL boom with No. 133A fixed jib

150 590 kg Counterweight
54 430 kg Carbody counterweight

8° Offset
Boom length m

Radius m	42,0	48,0	54,0	60,0	66,0
15,2	93,3				
22	81,4	82,1	82,6	82,6	77,9
28	58,9	58,3	57,6	57,0	56,4
34	44,0	43,4	42,7	41,9	41,3
40	34,1	33,3	32,7	31,9	31,3
46	26,9	26,1	25,5	24,0	24,0
52	21,4	20,7	20,0	19,2	18,6
58	17,1	16,4	15,8	15,0	14,3
64		12,9	12,3	11,5	10,9
72				7,8	7,2
80					4,2

21,3 m fixed jib length

20° Offset
Boom length m

Radius m	42,0	48,0	54,0	60,0	66,0
15,2					
22	60,9	63,0	64,6	66,2	
28	51,7	54,1	55,7	57,5	58,6
34	44,8	45,0	44,4	43,9	43,4
40	35,2	34,6	34,1	33,4	32,9
46	27,7	27,1	26,5	25,9	25,4
52	22,1	21,4	20,9	20,2	19,7
58		16,9	16,4	15,8	15,2
64			12,8	12,1	11,6
72					7,7
80					

21,3 m fixed jib length

8° Offset
Boom length m

Radius m	42,0	48,0	54,0	60,0	66,0
18,3	70,0				
24	63,0	63,9	64,8	65,1	64,3
30	54,6	53,9	53,1	52,5	51,9
36	41,3	40,7	40,0	39,2	38,7
42	32,3	31,6	30,9	30,2	29,5
48	25,8	25,0	24,3	23,6	22,9
54	20,7	20,0	19,3	18,5	17,8
60	16,7	15,9	15,3	14,5	13,8
66		12,6	12,0	11,2	10,6
76				6,9	6,2
84					3,5

27,4 m fixed jib length

20° Offset
Boom length m

Radius m	42,0	48,0	54,0	60,0	66,0
18,3					
24	47,6				
30	40,8	42,5	47,6	44,7	45,7
36	35,7	37,4	38,5	39,7	40,6
42	31,6	33,1	32,6	31,9	31,5
48	26,8	26,2	25,6	25,0	24,5
54	21,5	20,9	20,3	19,7	19,1
60		16,6	16,1	15,4	14,9
66			12,6	12,0	11,4
76					6,9
84					

27,4 m fixed jib length

For complete chart, refer to www.cranelibrary.com.

Fixed jib load charts

360° Rating, kg x 1 000

No. 58 HL boom with No. 133A fixed jib

150 590 kg Counterweight
54 430 kg Carbody counterweight

8° Offset
Boom length m

Radius m	42,0	48,0	54,0	60,0	66,0
20,0	53,4				
28	45,9	46,6	47,4	47,7	47,7
34	41,3	42,3	43,3	43,7	43,7
40	35,8	35,1	34,4	33,7	33,1
46	28,5	27,8	27,1	26,3	25,7
52	23,0	22,3	21,5	20,8	20,1
58	18,7	17,9	17,2	16,4	15,8
64	15,2	14,4	13,7	12,9	12,2
70	12,3	11,6	10,8	10,1	9,3
80			7,0	6,2	5,5
88				3,7	

36,6 m fixed jib length

20° Offset
Boom length m

Radius m	42,0	48,0	54,0	60,0	66,0
20,0					
28	38,2				
34	33,3	34,1	35,0	35,6	36,3
40	29,4	30,3	31,2	32,1	32,8
46	26,3	27,3	28,2	28,4	27,8
52	23,7	23,7	23,1	22,5	21,9
58	19,7	19,1	18,5	17,9	17,3
64	16,0	15,4	14,8	14,1	13,6
70		12,3	11,7	11,0	10,5
80				6,9	6,3
88					

36,6 m fixed jib length

8° Offset
Boom length m

Radius m	42,0	48,0	54,0	60,0
22,9	43,5			
30	38,0	38,6	39,2	39,5
36	34,1	34,9	35,7	36,3
42	30,7	31,7	32,3	31,6
48	26,8	26,3	25,6	24,8
54	21,9	21,2	20,4	19,7
60	17,8	17,1	16,4	15,6
66	14,6	13,8	13,1	12,3
76	10,3	9,5	8,8	8,0
84			6,1	5,3
92				

42,7 m fixed jib length

20° Offset
Boom length m

Radius m	42,0	48,0	54,0	60,0
22,9				
30				
36	27,8	28,4	29,0	29,5
42	24,6	25,3	25,9	26,6
48	21,9	22,7	23,4	24,1
54	19,7	20,6	21,3	21,6
60	17,9	18,5	17,8	17,2
66	15,5	14,9	14,3	13,7
76		10,2	9,7	9,0
84				6,1
92				

42,7 m fixed jib length

For complete chart, refer to www.cranelibrary.com.

Luffing jib range diagram

No. 58 HL boom with No. 59 luffing jib

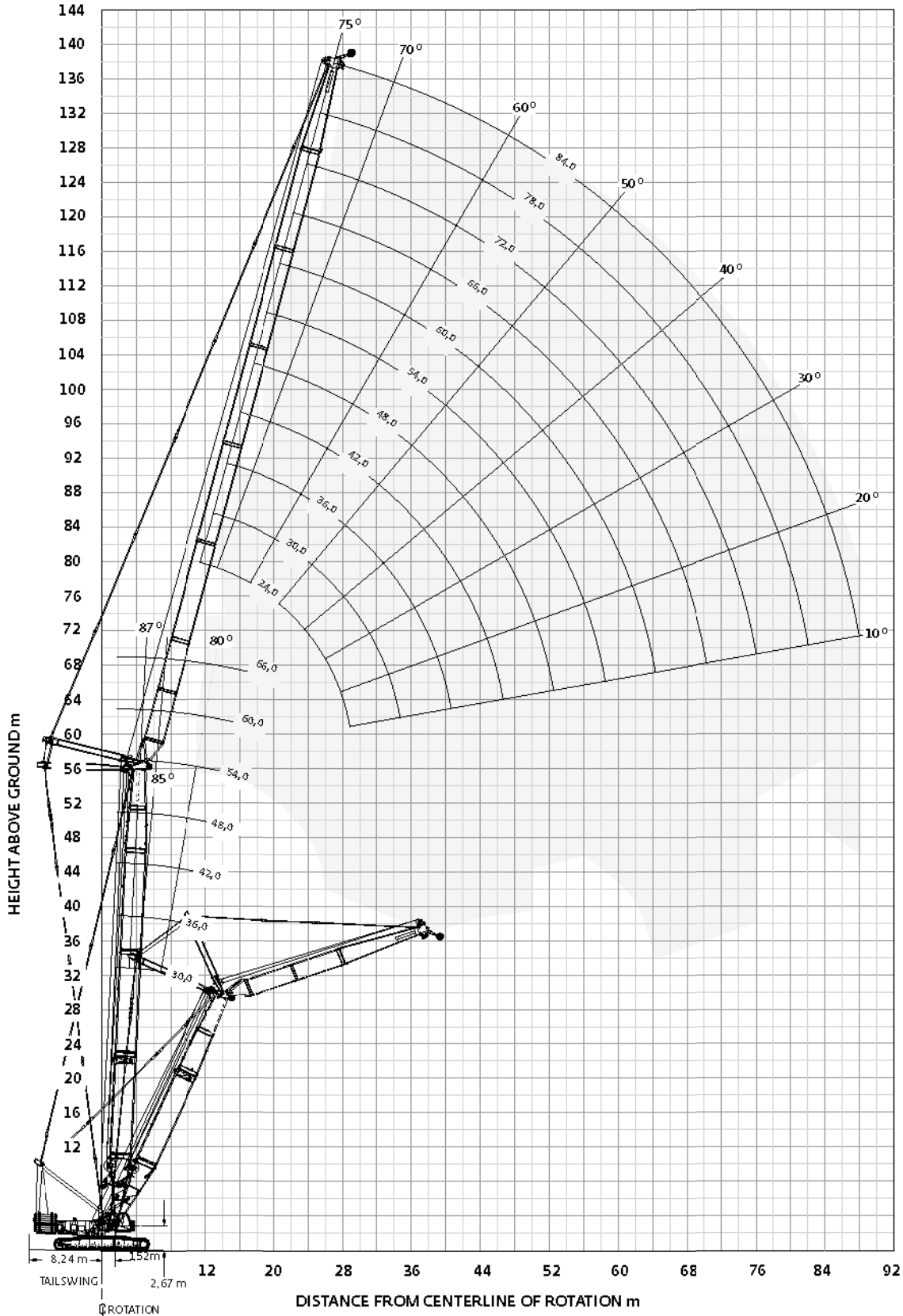

Luffing jib load charts

360° Rating, kg x 1 000

No. 58 HL boom with No. 59 luffing jib

150 590 kg Counterweight 54 430 kg Carbody counterweight

87° Boom angle

		Boom length m			
		30,0	42,0	54,0	66,0
24,0 m Luffing jib length	Radius m	30,0	42,0	54,0	66,0
	11,6	185,2			
	14,0	157,7	151,0	117,4	99,6
	18,0	121,1	112,6	97,8	84,8
	22,0	92,7	92,7	82,2	72,3
	26,0	74,6	73,9	69,5	62,1
	32,0				
	38,0				
	44,0				
	52,0				
56,0					
60,0					

		Boom length m			
		30,0	42,0	54,0	60,0
36,0 m Luffing jib length	Radius m	30,0	42,0	54,0	60,0
	15,2	136,1	116,8		
	16,0	131,2	113,3		
	18,0	118,9	104,3	89,0	84,5
	22,0	92,3	89,1	77,1	73,3
	26,0	74,4	74,3	67,1	64,0
	32,0	57,0	56,9	55,2	52,5
	38,0	45,6	45,5	44,8	43,0
	44,0				
	52,0				
56,0					
60,0					

		Boom length m			
		30,0	42,0	54,0	60,0
48,0 m Luffing jib length	Radius m	30,0	42,0	54,0	60,0
	18,3	107,4	92,1		
	22,0	91,9	81,6	70,3	66,6
	24,0	81,6	75,6	66,2	62,6
	30,0	61,2	61,0	55,5	52,6
	34,0	52,0	51,8	49,5	47,0
	38,0	44,9	44,8	44,4	42,0
	42,0	39,3	39,2	39,1	37,6
	46,0	34,8	34,7	34,5	33,7
	52,0				27,0
56,0					
60,0					

		Boom length m			
		30,0	42,0	54,0	60,0
60,0 m Luffing jib length	Radius m	30,0	42,0	54,0	60,0
	21,3	86,0	73,5		
	24,0	79,1	69,3	58,2	51,8
	28,0	65,9	62,1	53,2	49,6
	34,0	51,1	50,9	45,8	43,2
	40,0	41,1	40,9	39,4	37,2
	48,0	31,9	31,8	31,7	30,4
	56,0	25,6	25,5	25,3	24,9
	64,0	18,4	18,3	18,2	18,1
	72,0				
84,0					
88,0					

		Boom length m		
		30,0	42,0	54,0
72,0 m Luffing jib length	Radius m	30,0	42,0	54,0
	21,3			
	24,0			
	28,0	58,3	51,2	43,1
	34,0	49,9	48,2	40,6
	40,0	40,0	39,8	36,3
	48,0	30,9	30,7	30,3
	56,0	24,5	24,4	24,2
	64,0	19,8	19,7	19,5
	72,0	16,1	15,7	15,2
84,0				
88,0				

		Boom length m		
		30,0	42,0	54,0
84,0 m Luffing jib length	Radius m	30,0	42,0	54,0
	21,3			
	24,0			
	28,0	42,6	37,9	
	34,0	40,7	36,7	31,4
	40,0	38,7	35,4	30,0
	48,0	29,8	29,6	26,4
	56,0	23,4	23,3	22,7
	64,0	18,8	18,6	18,5
	72,0	15,2	15,1	14,9
84,0	10,6	9,6	9,1	
88,0		6,8	6,6	

For complete chart, refer to www.cranelibrary.com.

Luffing jib load charts

360° Rating, kg x 1 000

No. 58 HL boom with No. 59 luffing jib

150 590 kg Counterweight 54 430 kg Carbody counterweight

75° Boom angle

		Boom length m (ft)			
Radius m		30,0	42,0	54,0	66,0
24,0 m Luffing jib length	24,0	75,6			
	26,0	68,1	65,0		
	28,0	61,9	59,1		
	32,0	52,1	49,7	46,9	43,5
	36,0		42,5	40,2	37,2
	38,0			37,3	32,3
	42,0				30,2
	46,0				
	52,0				
	54,0				
	56,0				

		Boom length m			
Radius m		30,0	42,0	54,0	60,0
36,0 m Luffing jib length	24,0				
	26,0				
	28,0	61,1			
	32,0	51,4	48,7		
	36,0	44,0	41,7	39,1	
	38,0	41,0	38,9	36,3	34,9
	42,0	35,9	34,0	31,8	30,4
	46,0		30,0	28,0	26,8
	52,0				22,4
	54,0				
	56,0				

		Boom length m			
Radius m		30,0	42,0	54,0	60,0
48,0 m Luffing jib length	34,0	46,4			
	36,0	43,0			
	38,0	40,0	37,6		
	40,0	37,3	35,1	32,6	
	42,0	34,9	32,9	30,5	29,1
	44,0	32,8	30,8	28,5	27,2
	46,0	30,8	29,0	26,8	25,6
	50,0	27,4	25,7	23,7	22,6
	56,0	23,2	21,7	20,0	19,0
	60,0		19,5	17,9	17,0
	64,0			16,0	15,2

		Boom length m			
Radius m		30,0	42,0	54,0	60,0
60,0 m Luffing jib length	40,0	36,1			
	44,0	31,6	29,6		
	48,0	27,9	26,0	23,9	22,7
	54,0	23,5	21,8	19,9	18,8
	60,0	19,9	18,4	16,8	15,8
	66,0	17,0	15,7	14,2	13,3
	72,0		13,4	12,0	11,3
	76,0			10,7	10,0
	80,0				
	84,0				
	88,0				

		Boom length m		
Radius m		30,0	42,0	48,0
72,0 m Luffing jib length	40,0			
	44,0			
	48,0	26,6	24,7	
	54,0	22,2	20,5	19,5
	60,0	18,7	17,1	16,3
	66,0	15,9	14,5	13,6
	72,0	13,5	12,2	11,5
	76,0	12,1	10,9	10,3
	80,0		9,8	9,1
	84,0		8,7	8,1
	88,0			

		Boom length m
Radius m		30,0
84,0 m Luffing jib length	40,0	
	44,0	
	48,0	
	54,0	21,0
	60,0	17,5
	66,0	14,7
	72,0	12,3
	76,0	11,0
	80,0	9,8
	84,0	8,7
	88,0	7,7

For complete chart, refer to www.cranelibrary.com.

Luffing jib load charts

360° Rating, kg x 1 000

No. 58 HL boom with No. 59 luffing jib

150 590 kg Counterweight 54 430 kg Carbody counterweight

65° Boom angle

		Boom length m			
Radius m	30,0	42,0	54,0	66,0	
24,0 m Luffing jib length	32,0	47,9			
	36,0	41,0			
	40,0	61,9	32,4		
	44,0		28,2	25,0	
	48,0			21,9	18,5
	52,0				16,2
	56,0				
	60,0				
	62,0				
	68,0				
	72,0				

		Boom length m			
Radius m	30,0	42,0	54,0	60,0	
36,0 m Luffing jib length	32,0				
	36,0				
	40,0	34,8			
	44,0	30,6	27,4		
	48,0	27,0	24,2		
	52,0		21,5	18,4	16,6
	54,0		20,3	17,4	15,7
	60,0			14,6	13,1
	62,0				12,3
	68,0				
	72,0				

		Boom length m		
Radius m	30,0	42,0	54,0	
48,0 m Luffing jib length	32,0			
	36,0			
	40,0			
	44,0			
	48,0	26,0		
	52,0	23,1	20,3	
	54,0	21,9	19,1	
	60,0	18,5	16,2	13,3
	62,0	17,5	15,3	12,6
	68,0			10,6
	72,0			9,3

		Boom length m	
Radius m	30,0	42,0	
60,0 m Luffing jib length	54,0	20,6	
	56,0	19,5	
	58,0	18,4	15,7
	60,0	17,4	14,8
	64,0	15,6	13,2
	68,0	14,0	11,8
	72,0	12,6	10,5
	74,0	11,8	9,9
	76,0		9,3
	80,0		
	84,0		

		Boom length m
Radius m	30,0	
72,0 m Luffing jib length	54,0	
	56,0	
	58,0	
	60,0	16,1
	64,0	14,3
	68,0	12,7
	72,0	11,3
	74,0	10,7
	76,0	10,1
	80,0	9,0
	84,0	7,9

For complete chart, refer to www.cranelibrary.com.

Outline dimensions

MAX-ER®

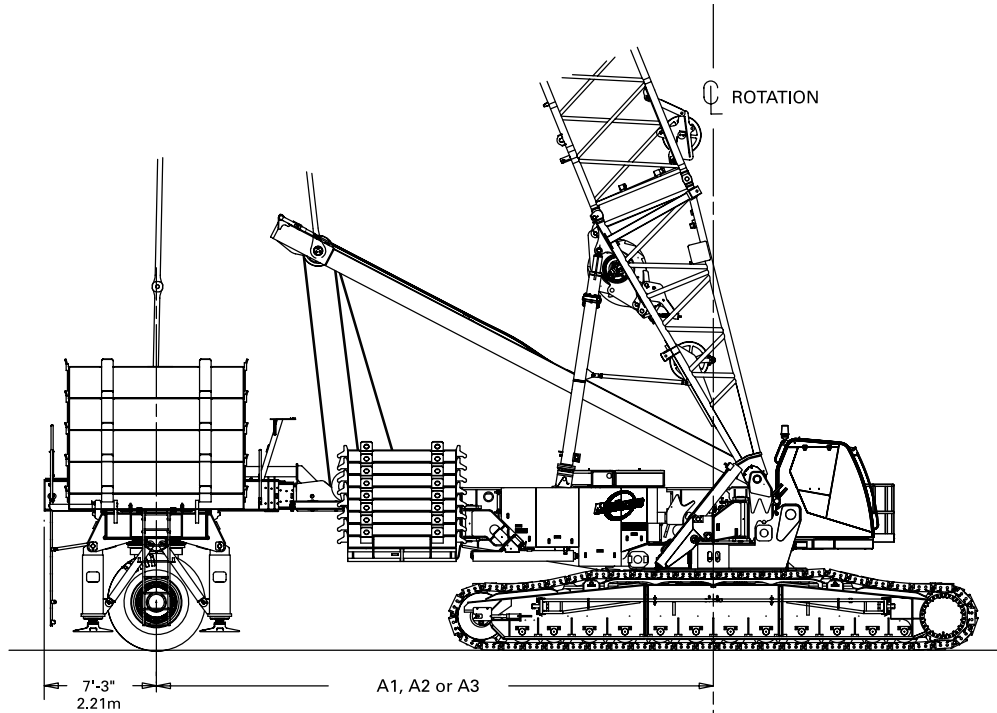

- A1 36'-1" (11m WORKING POSITION)
- A2 42'-8" (13m WORKING POSITION)
- A3 49'-3" (15m WORKING POSITION)

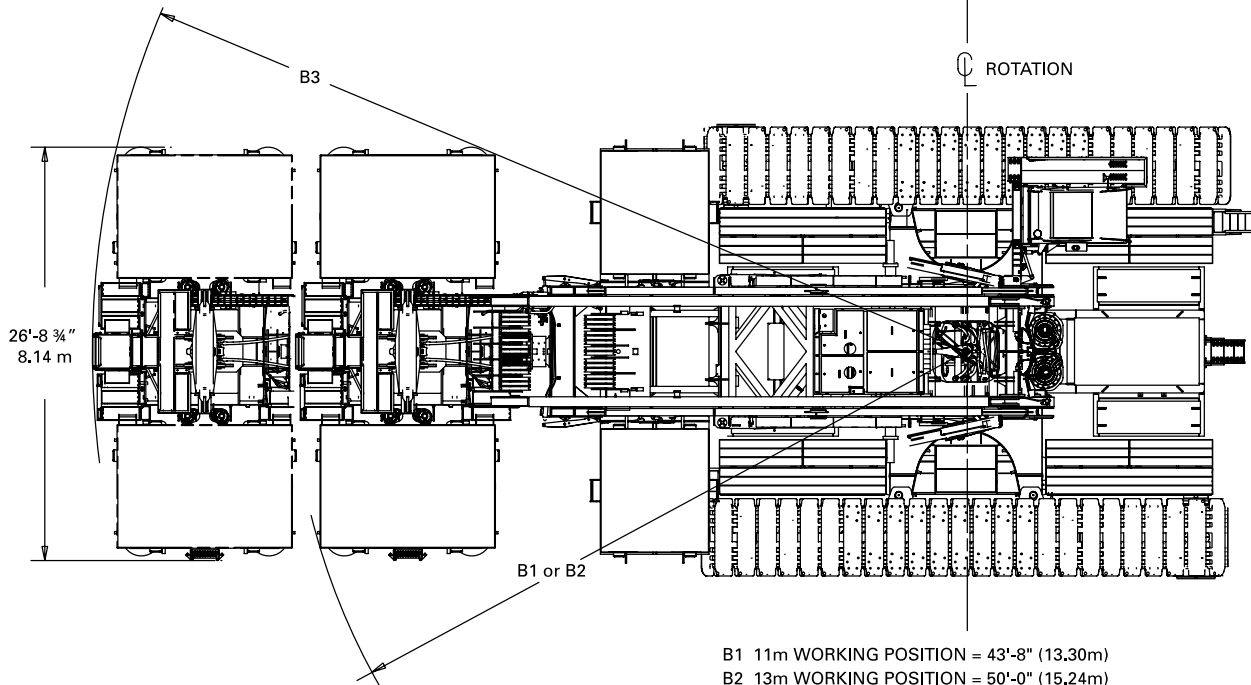

- B1 11m WORKING POSITION = 43'-8" (13.30m)
- B2 13m WORKING POSITION = 50'-0" (15.24m)
- B3 15m WORKING POSITION = 56'-6" (17.22m)

Outline dimensions

MAX-ER®

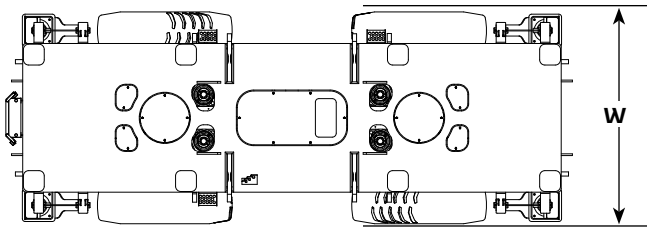

Wheeled carrier (US)

Length	8,15 m
Width	3,05 m
Height	3,00 m
Weight	28 304 kg

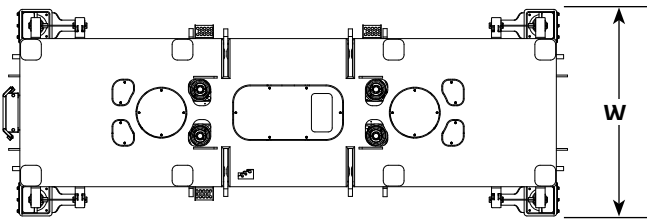
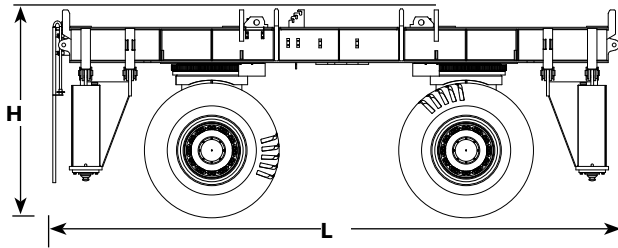

Wheeled carrier (European)

Length	8,15 m
Width	2,98 m
Height	3,00 m
Weight	28 622 kg

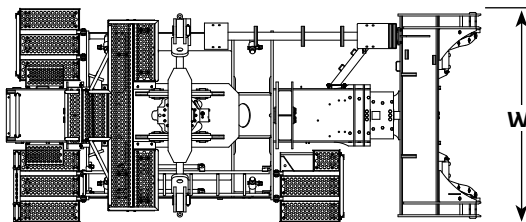
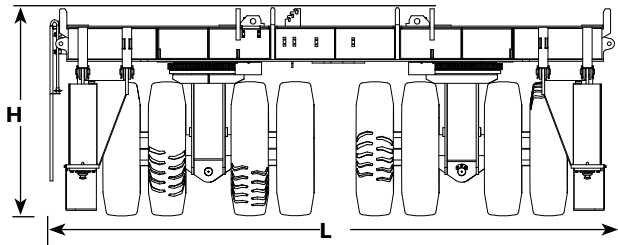

Lifting frame and telescopic beam

Length	6,04 m
Width	2,73 m
Height	2,99 m
Weight	16 828 kg

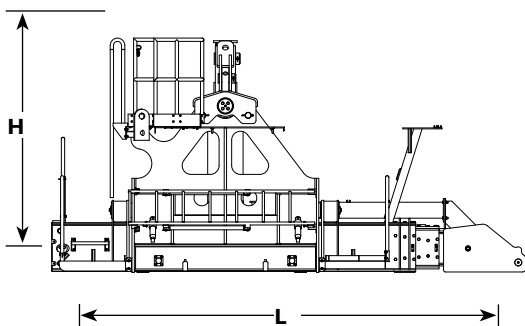

Outline dimensions

MAX-ER®

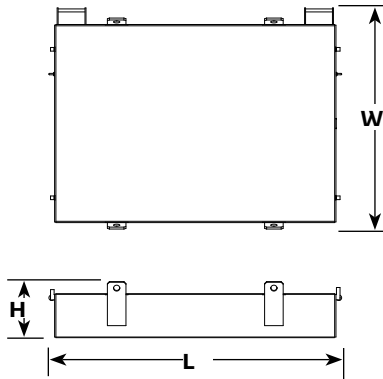

Side counterweight

Length	3,59 m
Width	2,72 m
Height	0,69 m
Weight	13 608 kg

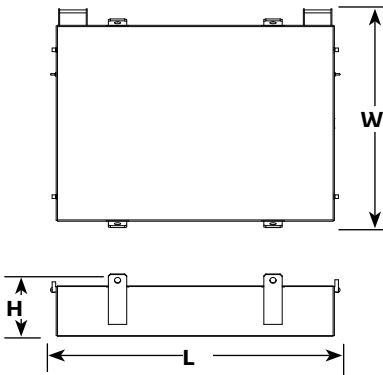

Side counterweight

Length	3,59 m
Width	2,72 m
Height	0,78 m
Weight	19 958 kg

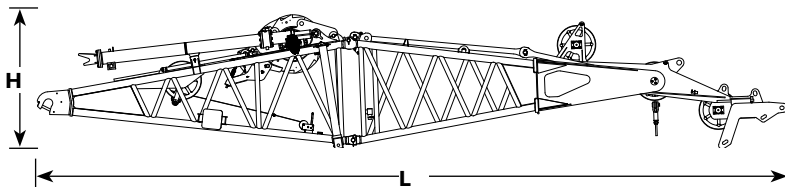

No. 59A mast butt and top package, drum, wire rope, equilizer

Length	14,84 m
Width	2,99 m
Height	2,66 m
Weight	20 593 kg

Outline dimensions

MAX-ER®

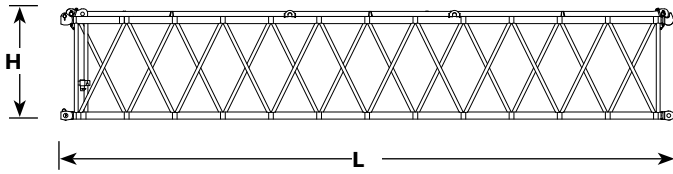

12 m No. 59A mast insert

Length	12,19 m
Width	2,72 m
Height	2,23 m
Weight	4 375 kg

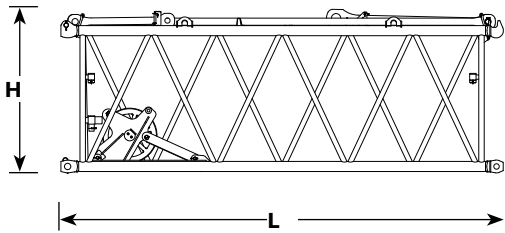

6 m No. 59A mast insert

Length	6,19 m
Width	2,72 m
Height	2,29 m
Weight	3 366 kg

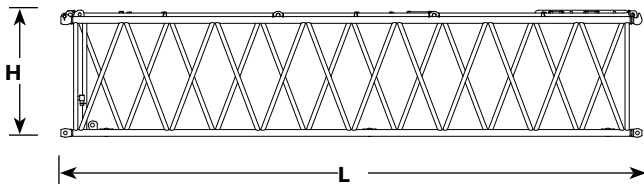

12 m No. 58 heavy boom insert with equilibrizer rails

Length	12,19 m
Width	2,98 m
Height	2,67 m
Weight	4 602 kg

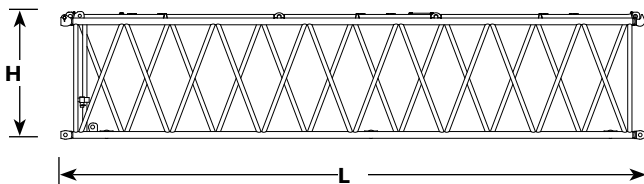

12 m No. 58 heavy boom insert

Length	12,19 m
Width	2,98 m
Height	2,67 m
Weight	5 087 kg

Boom combinations with mast

No. 58 HL boom combinations

Boom length m	Boom inserts length m				
	5,0°	6,0	12,0	12,0 ^{oo}	12,0 ^{ooo}
42	1	0	0	1	1
48	1	1	0	1	1
54	1	0	1	1	1
60	1	1	1	1	1
66	1	0	2	1	1
72	1	1	2	1	1
78	1	0	3	1	1
84	1	1	3	1	1
90	1	0	4	1	1
96	1	1	4	1	1

*transition boom insert.

**with auxiliary sheave insert.

*** with equalizer rails insert.

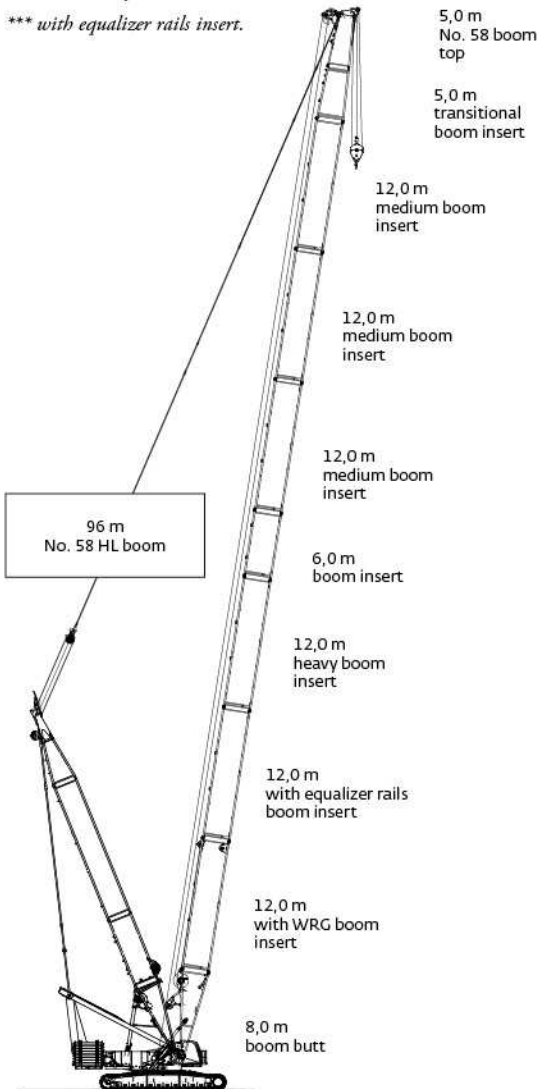

No. 58 HL boom with 7m extended upper boom point combination

Boom length m	Boom inserts length m					
	5,0°	6,0	12,0 medium	12,0 ^{oo}	12,0 ^{ooo}	12,0 heavy
96	1	1	3	1	1	1

*transition boom insert.

**with auxiliary sheave insert.

*** with equalizer rails insert.

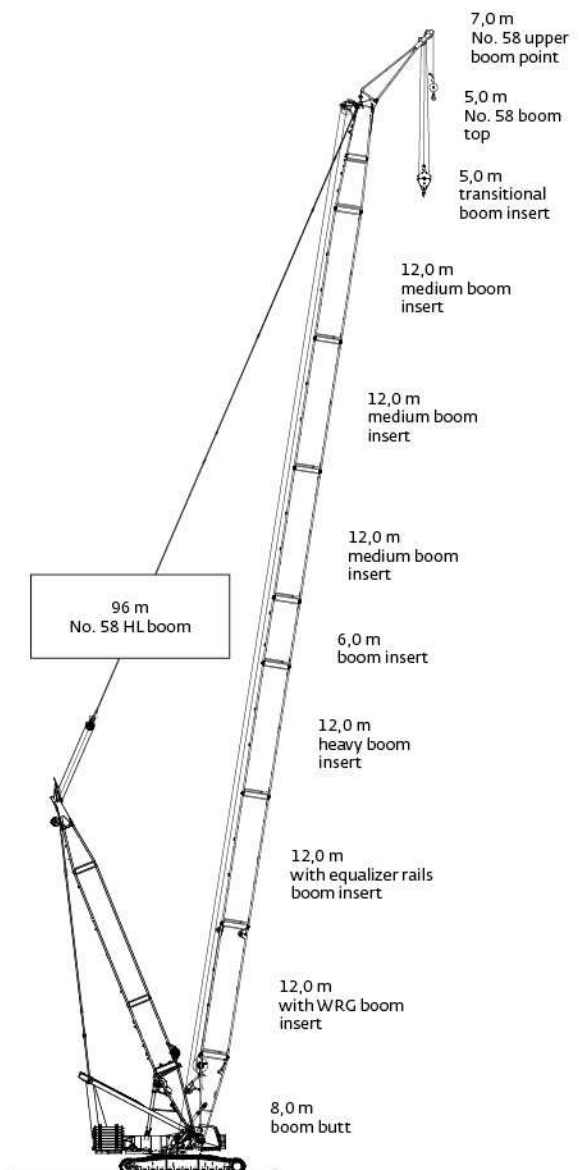

Boom combinations

MAX-ER®

No. 58 HL boom combinations						
Boom length m	Boom inserts length m					
	5,0°	6,0	12,0 medium	12,0 ^{oo}	12,0 ^{ooo}	12,0 heavy
42	1	0	0	1	1	0
48	1	1	0	1	1	0
54	1	0	0	1	1	1
60	1	1	0	1	1	1
66	1	0	1	1	1	1
72	1	1	1	1	1	1
78	1	0	2	1	1	1
84	1	1	2	1	1	1
90	1	0	3	1	1	1
96	1	1	3	1	1	1
102	1	0	4	1	1	1
108	1	1	4	1	1	1
114	1	0	5	1	1	1
120	1	1	5	1	1	1

*transition boom insert.
 **with auxiliary sheave insert.
 *** with equalizer rails insert.

No. 59 luffing jib combinations		
Luffing jib length m	Luffing jib inserts length m	
	6,0	12,0
24	1	0
30	0	1
36	1	1
42	0	2
48	1	2
54	0	3
60	1	3
66	0	4
72	1	4
78	0	5
84	1	5

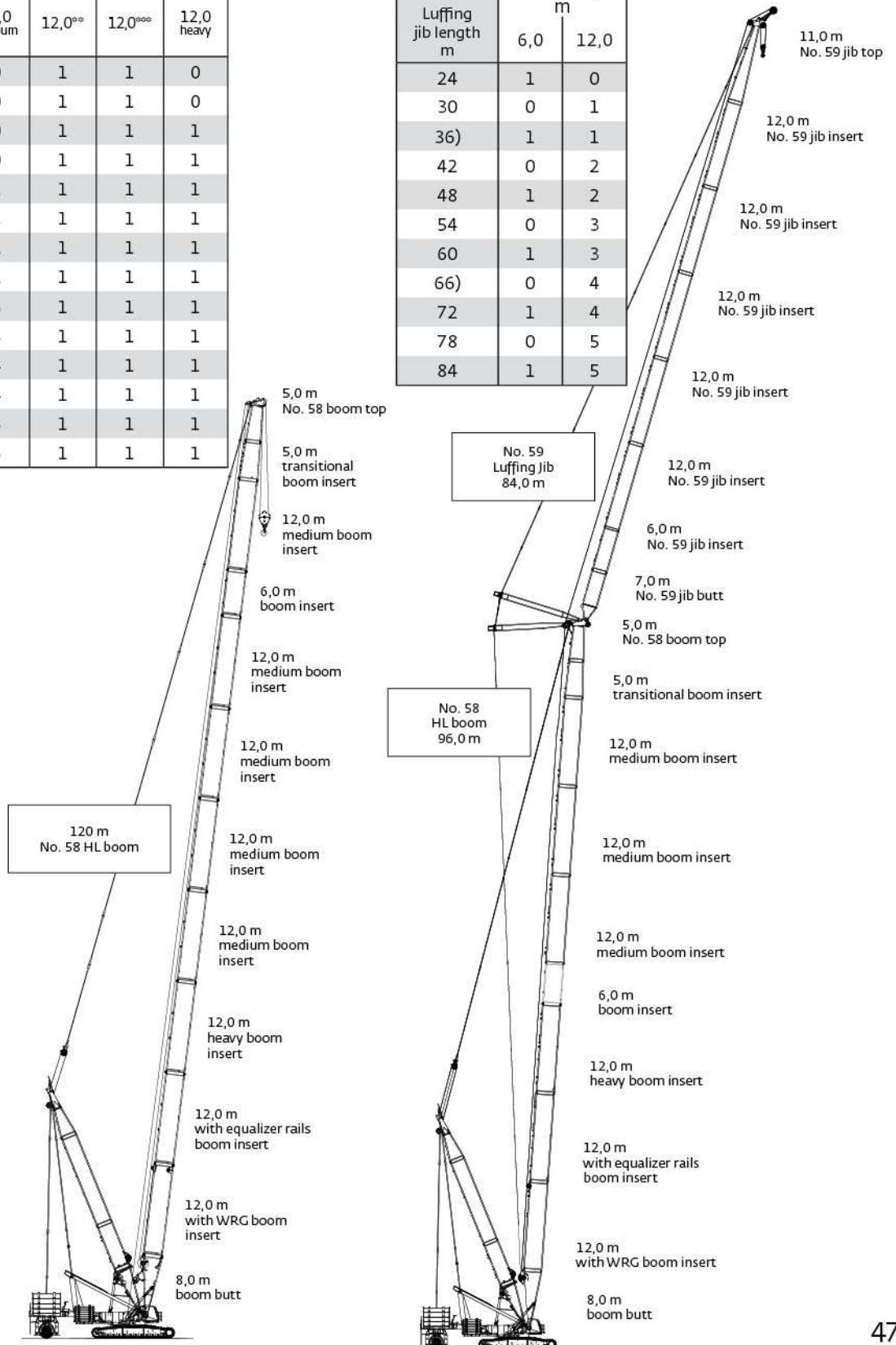

Boom range diagram with Mast

No. 58 HL boom with 30,0 m No.59A mast

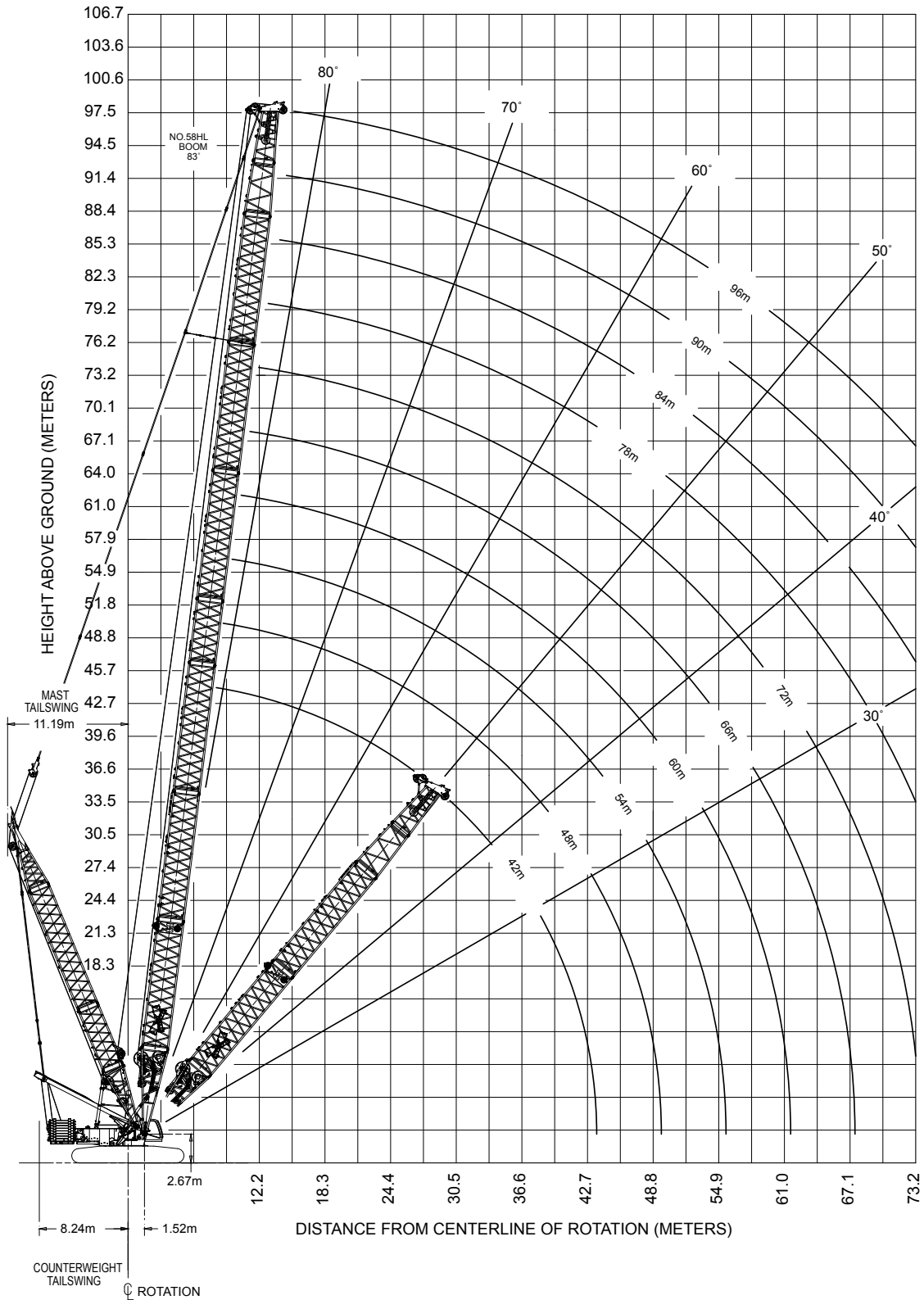

Boom load charts with Mast

360° Rating, kg x 1 000

No. 58 HL boom with 30,0 m No.59A mast										
Radius m	150 590 kg Counterweight 54 430 kg Carbody counterweight									
	Boom length m									
	42,0	48,0	54,0	60,0	66,0	72,0	78,0	84,0	90,0	96,0
8,0	332,1									
12,0	215,4	215,7	215,5	215,3	215,4	215,1				
16,0	140,0	140,1	140,0	139,7	139,8	139,4	139,2	138,8	138,9	126,9
20,0	101,7	101,6	101,3	101,0	101,0	100,5	100,2	99,7	99,4	98,9
24,0	78,4	78,2	77,9	77,5	77,4	76,9	76,5	75,9	75,7	75,0
28,0	62,7	62,5	62,2	61,7	61,7	61,1	60,7	60,1	59,7	59,0
32,0	51,5	51,2	50,9	50,4	50,3	49,7	49,3	48,6	48,3	47,5
36,0	43,0	42,7	42,3	41,8	41,7	41,1	40,7	40,0	39,7	38,9
40,0	36,3	36,0	35,7	35,1	35,1	34,4	34,0	33,3	32,9	32,2
44,0		30,7	30,3	29,8	29,7	29,1	28,6	27,9	27,6	26,8
48,0			25,8	25,3	25,3	24,7	24,2	23,5	23,1	22,4
52,0			22,1	21,7	21,6	20,9	20,5	19,8	19,4	18,6
56,0				18,5	18,4	17,8	17,3	16,7	16,3	15,5
60,0					15,7	15,1	14,6	13,9	13,6	12,7
64,0					13,2	12,7	12,2	11,6	11,2	10,4
70,0						9,6	9,2	8,5	8,2	7,2
80,0								3,7		

Extended upper boom point range diagram

No. 58 HL boom with 30,0 No. 59A mast and 7,0 m extended upper boom point

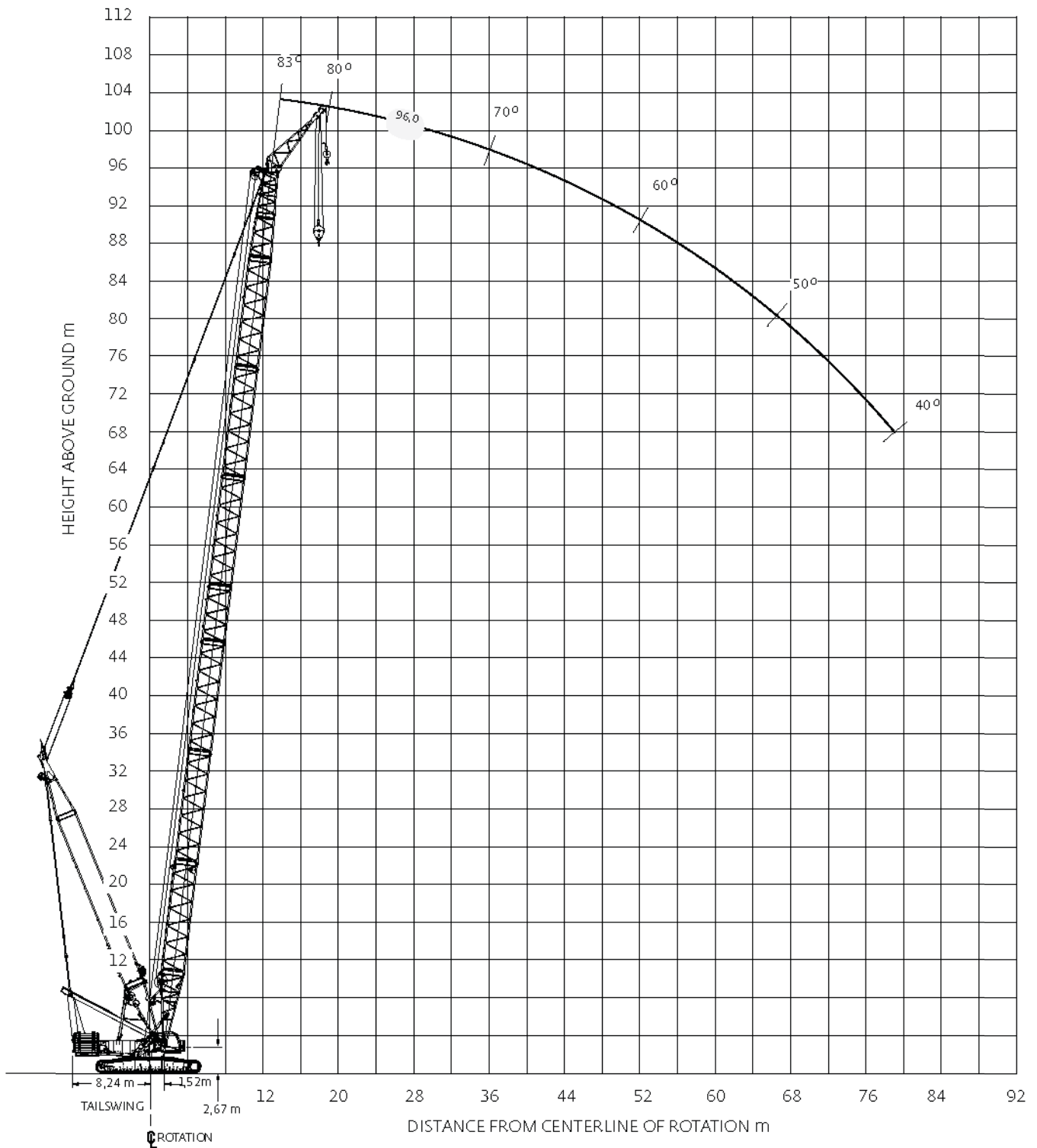

Extended upper boom point load charts

360° Rating, kg x 1 000

No. 58 HL boom with 30,0 No. 59A mast and 7,0 m extended upper boom point	
Radius m	150 590 kg Counterweight 54 430 kg Carbody counterweight
	Boom length m
	96,0
18,3	81,5
20,0	81,5
22,0	81,5
24,0	78,4
26,0	70,2
30,0	56,3
32,0	50,9
34,0	46,1
36,0	41,9
38,0	38,3
42,0	32,0
46,0	27,0
50,0	22,8
54,0	19,3
58,0	16,3
62,0	13,6
64,0	12,5
66,0	11,4
70,0	9,3
72,0	8,4
74,0	7,5
78,0	5,6
80,0	4,6
82,0	3,8

For complete chart, refer to www.cranelibrary.com.

MAX-ER[®] range diagram

MAX-ER at 15 m position
No. 58 HL boom with 30,0 m No.59A mast

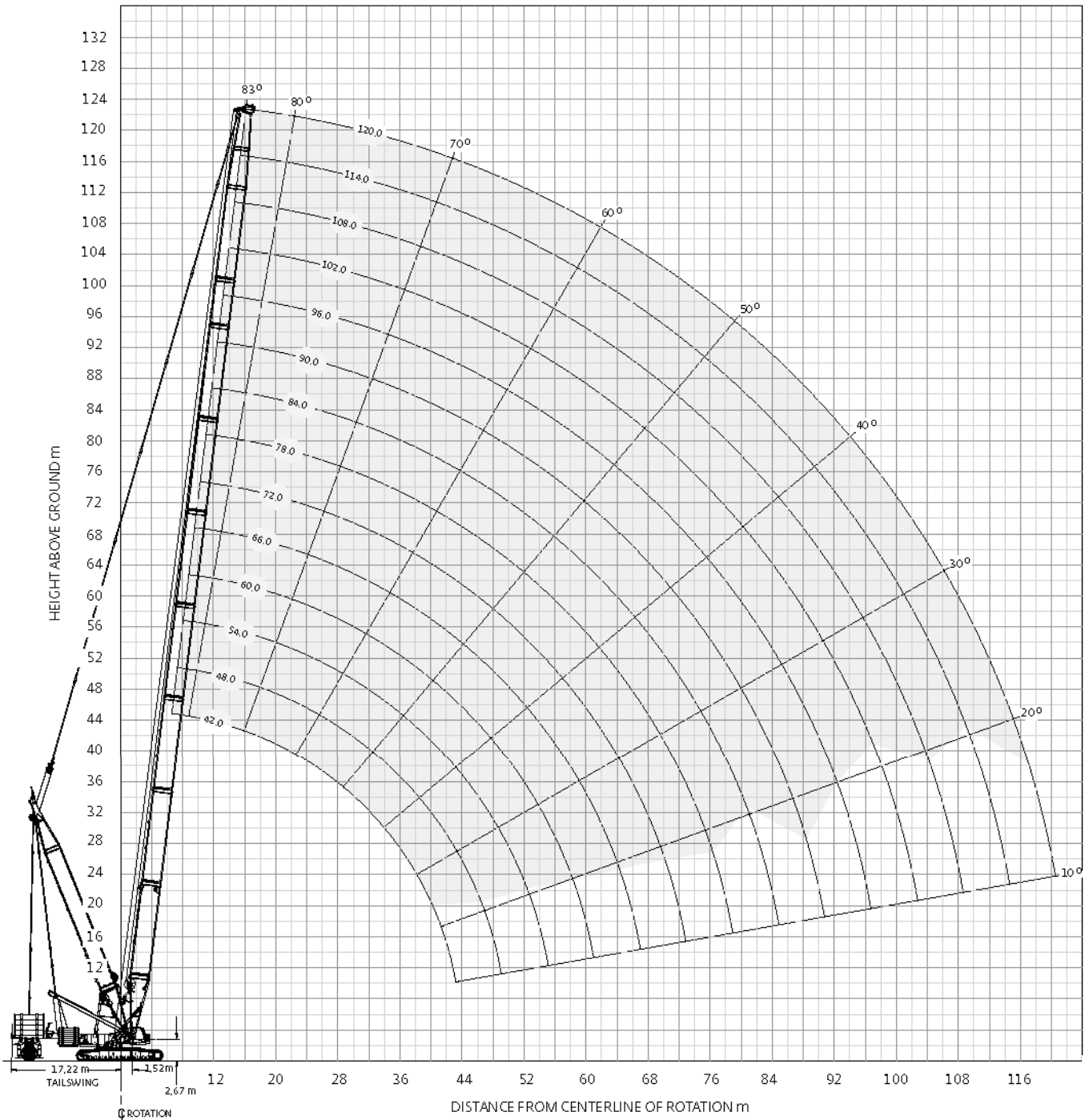

MAX-ER® load charts

360° Rating, kg x 1 000

MAX-ER at 15 m position No. 58 HL boom with 30,0 m No.59A mast														
Radius m	150 590 kg Counterweight 54 430 kg Carbody counterweight 231 970 kg Wheeled counterweight													
	Boom length m													
	42,0	48,0	54,0	60,0	66,0	72,0	78,0	84,0	90,0	96,0	102,0	108,0	114,0	120,0
7,9	379,8													
10,0	379,8	340,0	312,2											
12,0	379,8	340,0	311,4	282,4	251,1	227,8								
14,0	361,9	338,1	310,6	277,8	250,4	225,2	203,5	177,0	148,4					
18,0	278,9	278,4	279,5	267,1	241,4	217,8	198,9	177,0	148,4	126,9	107,8	92,9	79,7	
20,0	250,4	249,8	249,2	248,8	236,9	214,2	196,6	176,8	148,4	126,9	107,8	92,9	79,5	68,8
24,0	207,1	206,6	206,0	205,2	205,0	203,4	192,2	170,4	145,3	126,9	107,6	92,7	79,3	68,6
30,0	163,3	162,8	162,2	161,5	161,3	160,5	159,9	158,7	137,0	126,6	106,5	91,0	77,6	67,1
36,0	133,8	133,3	132,7	132,1	131,8	131,0	130,5	129,6	128,5	124,1	104,2	89,0	75,7	65,0
42,0		112,1	115,5	110,8	110,6	109,8	109,3	108,5	108,0	107,1	102,0	87,0	73,9	61,1
48,0			95,4	94,8	94,6	93,9	93,3	92,5	92,1	91,1	90,6	84,9	72,1	57,6
54,0				82,2	82,1	81,4	80,8	80,0	79,6	78,7	78,1	77,3	70,2	54,0
60,0					71,8	71,1	70,6	69,9	69,5	68,6	68,1	67,3	66,8	50,4
66,0						62,7	62,2	61,4	61,1	60,2	59,7	58,9	58,3	46,8
74,0							53,1	52,3	52,0	51,1	50,6	49,8	49,3	42,1
80,0								46,6	46,3	45,5	45,0	44,2	43,7	38,5
84,0									43,0	42,2	41,7	40,9	40,4	36,6
96,0											33,4	32,6	32,1	31,1
100,0												30,3	29,8	28,8
108,0													16,8	23,9
112,0														21,6
116,0														17,8

For complete chart, refer to www.cranelibrary.com.

Luffing jib range diagram

MAX-ER®

MAX-ER at 15 m position
 No. 58 HL boom with No. 59 luffing jib

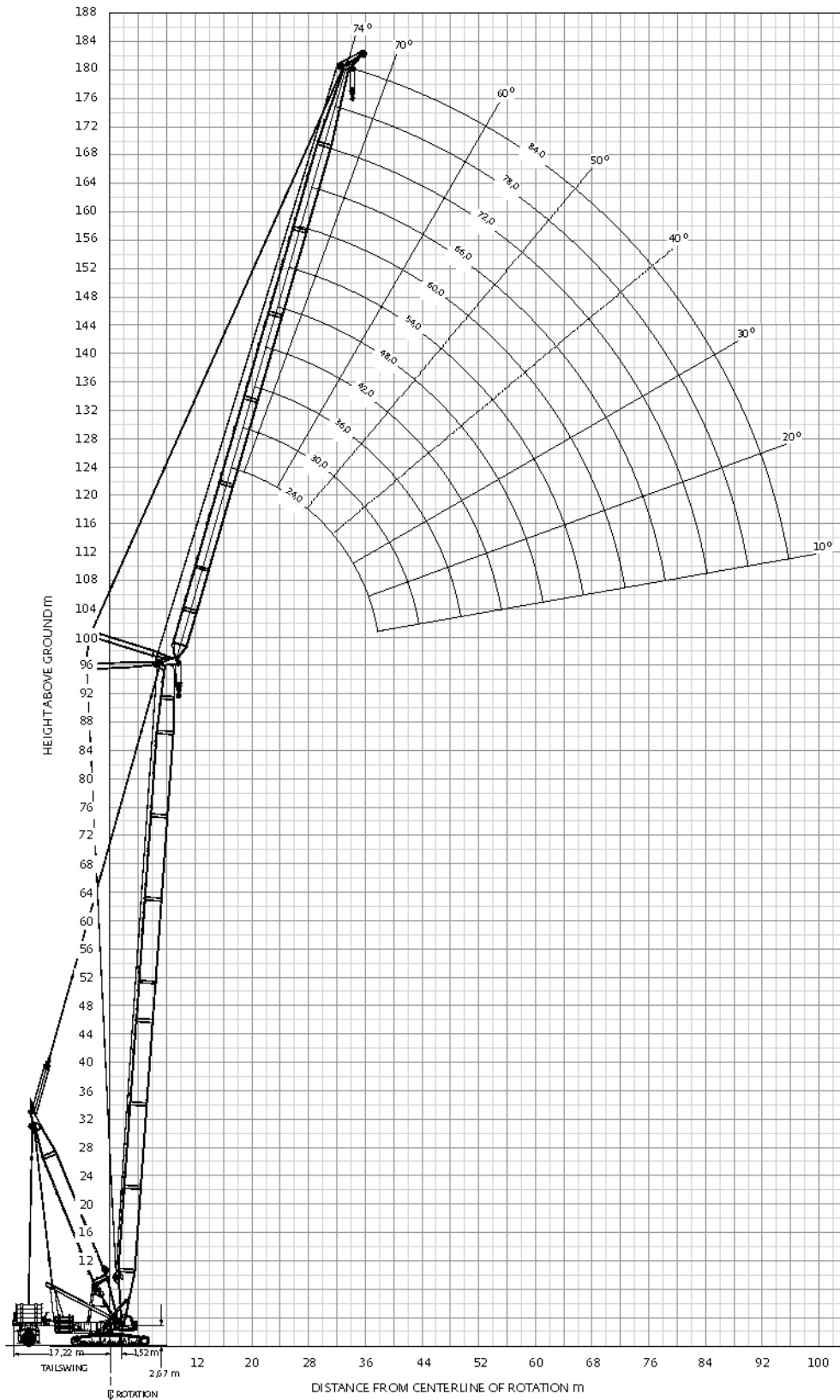

Luffing jib load charts

MAX-ER®

360° Rating, kg x 1 000

**MAX-ER at 15 m position
No. 58 HL boom with No. 59 luffing jib**

**150 590 kg Counterweight 54 430 kg Carbody counterweight
231 970 kg Wheeled counterweight
86° Boom angle**

	Boom length m				Radius m	Boom length m				Radius m	Boom length m				Radius m
	42,0	60,0	78,0	96,0		42,0	60,0	78,0	96,0		42,0	60,0	78,0	96,0	
24,0 m Luffing jib length	13,7	185,4	146,8			18,0	139,7				20,0	115,5			
	14,0	181,7	129,8			20,0	124,2	111,3	76,4		22,0	111,7	85,3		
	16,0	156,7	117,1			24,0	101,2	94,7	68,7	47,4	26,0	94,5	77,2	54,9	38,1
	18,0	137,6	107,2	98,6	62,2	26,0	93,0	87,6	64,7	46,0	30,0	80,1	68,3	49,8	35,5
	20,0	123,4	99,3	92,6	60,5	28,0	86,2	81,6	60,8	43,7	34,0	70,1	59,8	44,7	32,4
	22,0	112,3	96,4	86,5	59,0	32,0	75,9	70,2	53,5	39,4	38,0	62,7	52,1	39,9	29,4
	24,0	103,8	89,4	80,7	57,2	34,0	72,2	64,9	50,2	37,4	42,0	55,9	45,5	35,6	26,7
	26,0	97,4	79,1	75,3	54,3	36,0	69,1	60,3	47,3	35,6	46,0	48,5	40,1	32,1	24,4
	28,0	89,8		70,8	51,5	38,0	65,8	56,4	44,8	33,9	50,0	42,9	36,0	29,2	22,5
	30,0			67,4	49,2	42,0			41,3	31,4	54,0			27,6	21,2
32,0				47,0	44,0				30,9	56,0				21,1	
60,0 m Luffing jib length															
	24,0	79,7				28,0	55,4	46,9			32,0	39,4			
	28,0	78,3	61,0	43,8	30,1	32,0	54,5	46,0	33,6	23,5	38,0	38,0	33,6	25,1	17,4
	32,0	71,4	55,8	40,6	28,7	38,0	51,6	41,3	30,4	21,4	44,0	36,7	30,9	22,9	15,9
	38,0	60,5	47,7	35,4	25,4	44,0	45,4	36,2	27,0	19,2	50,0	34,3	27,7	20,6	14,3
	42,0	53,5	42,6	32,1	23,4	50,0	39,3	31,4	23,7	17,0	56,0	30,5	24,6	18,4	12,8
	46,0	47,2	37,9	29,0	21,4	54,0	35,6	28,5	21,7	15,6	62,0	27,1	21,7	16,3	11,3
	50,0	41,7	33,8	26,3	19,6	58,0	32,1	25,8	19,9	14,4	68,0	23,9	19,2	14,6	10,1
	56,0	35,0	28,7	22,9	17,3	64,0	27,8	22,5	17,5	12,8	74,0	21,3	17,0	13,0	9,1
	60,0	31,5	26,2	21,1	16,1	70,0	24,3	19,9	15,7	11,6	80,0	18,2	15,3	11,8	8,3
64,0	27,0	24,4	19,9	15,2	76,0	21,6	18,2	14,6	10,8	86,0	14,5	14,1	11,1	7,7	
68,0				14,9	80,0				10,7	92,0				7,5	

For complete chart, refer to www.cranelibrary.com.

Manitowoc Crane Care

Manitowoc Crane Care is the industry's most advanced service and support program, designed to keep your cranes up and running. Manitowoc's distributor network and customer support personnel are available to support you 24 hours a day, 7 days a week, 365 days a year. There are five key disciplines of Manitowoc Crane Care:

Parts

Genuine Manitowoc replacement parts are accessible through your distributor.

Service and technical support

Assistance with crane selection, lift planning and ground bearing calculations or field service and maintenance.

Technical publications

Operator, parts, service and capacity chart manuals are available in multiple formats in major languages.

Training

A variety of training courses are available online or through Manitowoc training centers.

EnCORE

Rebuild, repair, remanufacture or exchange your current crane through our local network, for a fraction of the cost of a new crane.

www.manitowoccranecare.com

CraneSTAR

CraneSTAR is an exclusive and innovative crane asset management system that helps improve your profitability and reduce costs by remotely monitoring critical crane data. Visit www.cranestar.com for more information.

Manitowoc Cranes

Regional headquarters

Americas

Manitowoc, Wisconsin, USA

Tel: +1 920 684 6621

Fax: +1 920 683 6277

Shady Grove, Pennsylvania, USA

Tel: +1 717 597 8121

Fax: +1 717 597 4062

Europe, Middle East, Africa

Ecully, France

Tel: +33 (0)4 72 18 20 20

Fax: +33 (0)4 72 18 20 00

China

Shanghai, China

Tel: +86 21 6457 0066

Fax: +86 21 6457 4955

Greater Asia-Pacific

Singapore

Tel: +65 6264 1188

Fax: +65 6862 4040

Regional offices

Americas

Brazil

Alphaville

Mexico

Monterrey

Chile

Santiago

Europe, Middle East,

Africa

France

Baudemont

Cergy

Decines

Germany

Langenfeld

Italy

Lainate

Netherlands

Breda

Poland

Warsaw

Portugal

Baltar

Russia

Moscow

South Africa

Johannesburg

U.A.E.

Dubai

U.K.

Buckingham

China

Beijing

Chengdu

Guangzhou

Xian

Greater Asia-Pacific

Australia

Brisbane

Melbourne

Sydney

India

Chennai

Delhi

Hyderabad

Pune

Korea

Seoul

Philippines

Makati City

Singapore

Factories

Brazil

Passo Fundo

China

TaiAn

Zhangjiagang

France

Charlieu

Moulins

Germany

Wilhelmshaven

India

Pune

Italy

Niella Tanaro

Portugal

Baltar

Fânzeres

Slovakia

Saris

USA

Manitowoc

Port Washington

Shady Grove

This document is non-contractual. Constant improvement and engineering progress make it necessary that we reserve the right to make specification, equipment, and price changes without notice. Illustrations shown may include optional equipment and accessories and may not include all standard equipment.