

LOAD CHARTS - MANTIS Railroad Rerailer Model 30011

WARNING

Do not operate this equipment without first reading and understanding the operator's manual; including the permissible load limits.

It is extremely hazardous:

- to operate this equipment without applicable load charts and Operators Manual in the cab or to allow the use of this equipment by any one other than an experienced, properly trained operator
- to exceed these limits
- to attempt a lift without the outrigger pads down and in contact with the Supporting Surface in accordance with the LOAD CHARTS
- to move boom from normal transit position unless all four outrigger pads are in contact with the Supporting Surface.
- to lift or otherwise operate this equipment on unstable supporting surfaces
- to lift a load with the crane and truck positioned out-of-level
- to use this equipment for other than vertical lifts
- to attempt a lift without knowing that the load is within the published limits of weight, boom angle, boom length, and radius, outrigger extension, and fifth outrigger requirements as shown on the applicable load charts in the operator's cab
- to operate within reach of electrical power lines
- to side load the boom

5th Outrigger MUST be in Place for Loads Exceeding 100,000 lb. in all Zones.

Boom Extension must be fully retracted for Load Capacities of 100,000 lb. or greater.

Capacity Limitations and General Conditions.

This MANTIS Railroad Rerailer Model 30011 Crane as manufactured by SpanDeck, Inc., meets the requirements of ANSI B30.5 (1989), (when specifically equipped). Structure and stability have been tested in accordance with industry standards. Lifting capacities as determined by boom length, angle, or radius, apply only to machines as originally equipped by manufacturer and in a properly maintained condition. Capacities given are maximum covered by the manufacturer's warranty and are based on a freely suspended load with NO allowance for factors as out-of-level operation, supporting surface conditions, hazardous surroundings, experience of personnel, etc. The operator shall establish practical working loads based on prevailing operating conditions, such as, but not limited to the above.

When making lifts where capacities may be within a zone limited by structural strength, the operator shall determine that the *weight of the load is known within plus or minus (+/-) ten percent (10%) before making lift.* **DO NOT** lift load or extend boom without all outriggers in place as required by the Load Charts. Deductions from rated capacities must be made for the weight of the hook block, hook/ball, slings, spreader bar, or other suspended equipment.

WARNING: Side pull on boom is extremely dangerous and must be avoided.

DO NOT exceed manufacturers maximum specified reeving.

Load radius is defined as the horizontal distance from the axis of rotation (with no load) to the center of the lifting device after the load is applied.

Boom angle is the included angle between the Longitudinal axis of the boom base section and the Horizontal axis after lifting load. The boom angle before lifting should be slightly greater than desired to account for boom deflection.

Boom angle/boom length relationships given are an approximation of the resulting load radius, which should be an accurate measurement.

Boom height dimensions are measured from ground to center of lower boom head sheaves.

It is permissible to attempt to telescope boom with a load within the limits of rated capacities. However, boom angle, system hydraulic pressure, and/or boom lubrication may affect operation.

Load Charts - MANTIS Railroad Rerailer Model 30011

SW: Operating Mode Selector
Switch (Ref. [17] PAT Console)
(Not used on PAT systems with Graphic Control Console)

SW	Operating Mode	Chart	Page
	Full Rear Outriggers, Full Front Outriggers		
01	Mainboom over rear (Zone 1)	1	3
01	Mainboom over corner (Zone 2)	2	3
01	Mainboom over side (Zone 3)	3	4
01	Mainboom over front (Zone 4)	4	4
	75% Rear Outriggers, Full Front Outriggers		
02	Mainboom over rear (Zone 1)	5	5
02	Mainboom over corner (Zone 2)	9	7
02	Mainboom over side (Zone 3)	9	7
02	Mainboom over front (Zone 4)	10	7
	50% Rear Outriggers, Full Front Outriggers		
03	Mainboom over rear (Zone 1)	5	5
03	Mainboom over corner (Zone 2)	8	6
03	Mainboom over side (Zone 3)	8	6
03	Mainboom over front (Zone 4)	10	7
	25% Rear Outriggers, Full Front Outriggers		
04	Mainboom over rear (Zone 1)	5	5
04	Mainboom over corner (Zone 2)	7	6
04	Mainboom over side (Zone 3)	7	6
04	Mainboom over front (Zone 4)	10	7
	0% Rear Outriggers, Full Front Outriggers		
05	Mainboom over rear (Zone 1)	5	5
05	Mainboom over corner (Zone 2)	6	5
05	Mainboom over side (Zone 3)	6	5
05	Mainboom over front (Zone 4)	10	7
	0% Rear Outriggers, Reduced Front Outriggers		
06	Mainboom 360 Degrees (Zones 1, 2, 3, 4)	10	7

Load Charts - MANTIS Railroad Rerailer Model 30011

CHART 1:

ZONE 1 Over the Rear
Rear Outriggers @ 100% Extension
Front Outriggers @ Proper Angle And
Extension

Radius, Ft.	Rated Load, Lb. x 1000	PAT SW-01
8	300.0	*
9	300.0	5th O.R.*
10	300.0	Required*
11	300.0	See Note*
12	283.0	*
13	212.0	*
14	169.0	*
15	140.0	*
16	119.0	*
17	103.0	*
18	91.0	
19	81.0	
20	73.0	
21	67.0	
22	61.0	
23	56.0	
24	52.0	
25	49.0	
26	45.0	
27	42.0	
28	40.0	
29	38.0	
30	35.0	
31	34.0	
32	32.0	
33	30.0	
34	29.0	
35	27.0	
36	26.0	
37	25.0	
38	24.0	
39	23.0	
40	22.0	

Shaded Area Indicates Structural Zone.

*** 5th Outrigger required to be In place for loads exceeding 100,000 lb. in all zones.**

CHART 2:

ZONE 2 Over the Corner
Rear Outriggers @ 100% Extension
Front Outriggers @ Proper Angle And
Extension

Radius, Ft.	Rated Load, Lb. x 1000	PAT SW-01
8	222.0	*
9	222.0	5th O.R.*
10	222.0	Required*
11	222.0	See Note*
12	222.0	*
13	179.0	*
14	137.0	*
15	110.0	*
16	92.0	
17	79.0	
18	68.0	
19	61.0	
20	54.0	
21	49.0	
22	44.0	
23	40.0	
24	37.0	
25	34.0	
26	32.0	
27	30.0	
28	28.0	
29	26.0	
30	24.0	
31	23.0	
32	22.0	
33	20.0	
34	19.0	
35	18.0	
36	17.0	
37	16.0	
38	16.0	
39	15.0	
40	14.0	

Boom Extension must be fully retracted for Load Capacities of 100,000 lb. or greater.

Load Charts - MANTIS Railroad Rerailer Model 30011

CHART 3:

ZONE 3: Over the Side

Rear Outriggers @ 100% Extension
Front Outriggers @ Proper Angle And
Extension

Radius, Ft.	Rated Load, Lb. x 1000	PAT SW-01
8	300.0	*
9	300.0	5th O.R.*
10	300.0	Required
11	300.0	See Note*
12	257.0	*
13	179.0	*
14	137.0	*
15	110.0	*
16	92.0	
17	79.0	
18	68.0	
19	61.0	
20	54.0	
21	49.0	
22	44.0	
23	40.0	
24	37.0	
25	34.0	
26	32.0	
27	30.0	
28	28.0	
29	26.0	
30	24.0	
31	23.0	
32	22.0	
33	20.0	
34	19.0	
35	18.0	
36	17.0	
37	16.0	
38	16.0	
39	15.0	
40	14.0	

Shaded Area Indicates Structural Zone.

*** 5th Outrigger required to be In place for loads exceeding 100,000 lb. in all zones.**

CHART 4:

ZONE 4: Over the Front

Rear Outriggers @ 100% Extension
Front Outriggers @ Proper Angle And
Extension

Radius, Ft.	Rated Load, Lb. x 1000	PAT SW-01
8	200.0	*
9	200.0	5th O.R.*
10	200.0	Required*
11	141.0	See Note*
12	92.0	
13	67.0	
14	52.0	
15	42.0	
16	35.0	
17	30.0	
18	26.0	
19	23.0	
20	20.0	
21	18.0	
22	16.0	
23	14.0	
24	13.0	
25	12.0	
26	11.0	
27	10.0	
28	9.0	
29	8.0	
30	7.0	
31	7.0	
32	6.0	
33	6.0	
34	5.0	
35	5.0	
36	4.0	
37	4.0	
38	3.0	
39	3.0	
40	3.0	

Boom Extension must be fully retracted for Load Capacities of 100,000 lb. or greater.

Load Charts - MANTIS Railroad Rerailer Model 30011

CHART 5:

ZONE 1: Over the Rear
 Rear Outriggers @ 0%, 25%, 50% Or
 75% Extension
 Front Outriggers @ Proper Angle And
 Extension

Radius, Ft.	Rated Load, Lb. x 1000
8	220.0
9	220.0
10	202.0
11	189.0
12	177.0
13	156.0
14	129.0
15	110.0
16	95.0
17	84.0
18	75.0
19	68.0
20	61.0
21	56.0
22	52.0
23	48.0
24	45.0
25	42.0
26	39.0
27	36.0
28	34.0
29	32.0
30	31.0
31	29.0
32	28.0
33	26.0
34	25.0
35	24.0
36	22.0
37	21.0
38	20.0
39	19.0
40	18.0

PAT
0% SW-05
25% SW-04
50% SW-03
75% SW-02
5th O.R.*
Required
See
Note

CHART 6:

ZONE 2 & 3: Over the Corner & Over the Side
 Rear Outriggers @ 0% Extension
 Front Outriggers @ Proper Angle And
 Extension

Radius, Ft.	Rated Load, Lb. x 1000
8	56.0
9	41.0
10	34.0
11	28.0
12	24.0
13	20.0
14	18.0
15	16.0
16	14.0
17	12.0
18	11.0
19	10.0
20	9.0
21	8.0
22	7.0
23	6.0
24	6.0
25	5.0
26	5.0
27	4.0
28	4.0
29	3.0
30	3.0
31	3.0
32	2.0
33	2.0
34	2.0
35	1.0
36	1.0
37	1.0
38	1.0
39	0.0
40	0.0

PAT
SW-05

Shaded Area Indicates Structural Zone.

*** 5th Outrigger required to be In place for loads exceeding 100,000 lb. in all zones.**

Boom Extension must be fully retracted for Load Capacities of 100,000 lb. or greater.

Load Charts - MANTIS Railroad Rerailer Model 30011

CHART 7:

ZONE 2 & 3

Over the Corner &
Over the Side

Rear Outriggers @ 25% Extension
Front Outriggers @ Proper Angle And
Extension

Radius, Ft.	Rated Load, Lb. x 1000	PAT SW-04
8	124.0	See Note*
9	85.0	
10	66.0	
11	53.0	
12	44.0	
13	38.0	
14	33.0	
15	29.0	
16	25.0	
17	23.0	
18	20.0	
19	18.0	
20	17.0	
21	15.0	
22	14.0	
23	13.0	
24	12.0	
25	11.0	
26	10.0	
27	9.0	
28	9.0	
29	8.0	
30	7.0	
31	7.0	
32	6.0	
33	6.0	
34	5.0	
35	5.0	
36	5.0	
37	4.0	
38	4.0	
39	4.0	
40	3.0	

Shaded Area Indicates Structural Zone.

*** 5th Outrigger required to be In place for loads exceeding 100,000 lb. in all zones.**

CHART 8:

ZONE 2 & 3:

Over the Corner &
Over the Side

Rear Outriggers @ 50% Extension
Front Outriggers @ Proper Angle And
Extension

Radius, Ft.	Rated Load, Lb. x 1000	PAT SW-03
8	222.0	5th O.R.*
9	184.0	Required*
10	126.0	See Note*
11	95.0	
12	76.0	
13	63.0	
14	54.0	
15	46.0	
16	41.0	
17	36.0	
18	32.0	
19	29.0	
20	26.0	
21	24.0	
22	22.0	
23	20.0	
24	19.0	
25	17.0	
26	16.0	
27	15.0	
28	14.0	
29	13.0	
30	12.0	
31	12.0	
32	11.0	
33	10.0	
34	10.0	
35	9.0	
36	8.0	
37	8.0	
38	7.0	
39	7.0	
40	7.0	

Boom Extension must be fully retracted for Load Capacities of 100,000 lb. or greater.

Load Charts - MANTIS Railroad Rerailer Model 30011

CHART 9:

ZONE 2 & 3

Over the Corner &
Over the Side

Rear Outriggers @ 75% Extension
Front Outriggers @ Proper Angle And
Extension

Radius, Ft.	Rated Load, Lb. x 1000
8	222.0
9	222.0
10	222.0
11	181.0
12	132.0
13	104.0
14	85.0
15	72.0
16	62.0
17	54.0
18	48.0
19	43.0
20	39.0
21	35.0
22	32.0
23	29.0
24	27.0
25	25.0
26	23.0
27	22.0
28	20.0
29	19.0
30	18.0
31	17.0
32	16.0
33	15.0
34	14.0
35	13.0
36	13.0
37	12.0
38	11.0
39	11.0
40	10.0

PAT
SW-02

*
5th O.R.*
Required*
See Note*
*

CHART 10:

ZONE 1, 2, 3, 4

360 Degrees

Rear Outriggers @ 0% Extension
Front Outriggers @ Reduced Angle And
Extension

Radius, Ft.	Rated Load, Lb. x 1000
8	56.0
9	41.0
10	34.0
11	28.0
12	24.0
13	20.0
14	18.0
15	16.0
16	14.0
17	12.0
18	11.0
19	10.0
20	9.0
21	8.0
22	7.0
23	6.0
24	6.0
25	5.0
26	5.0
27	4.0
28	4.0
29	3.0
30	3.0
31	3.0
32	2.0
33	2.0
34	2.0
35	1.0
36	1.0
37	1.0
38	1.0
39	0.0
40	0.0

PAT
SW-06

Shaded Area Indicates Structural Zone.

* 5th Outrigger required to be In place for loads exceeding 100,000 lb. in all zones.

Boom Extension must be fully retracted for Load Capacities of 100,000 lb. or greater.

Range Diagram - MANTIS Railroad Rerailer Model 30011

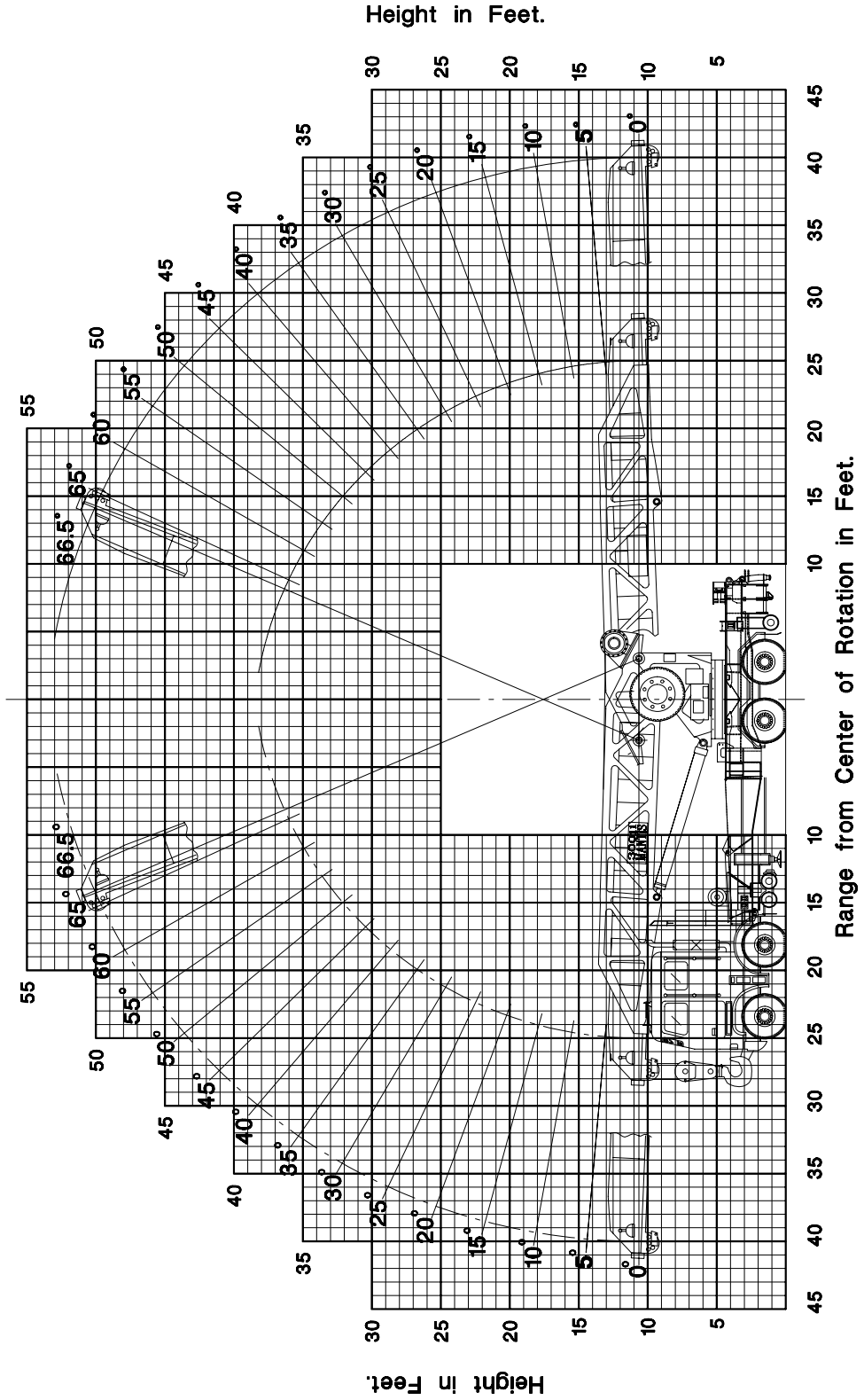

Operating Diagram, MANTIS Railroad Rerailer Model 30011

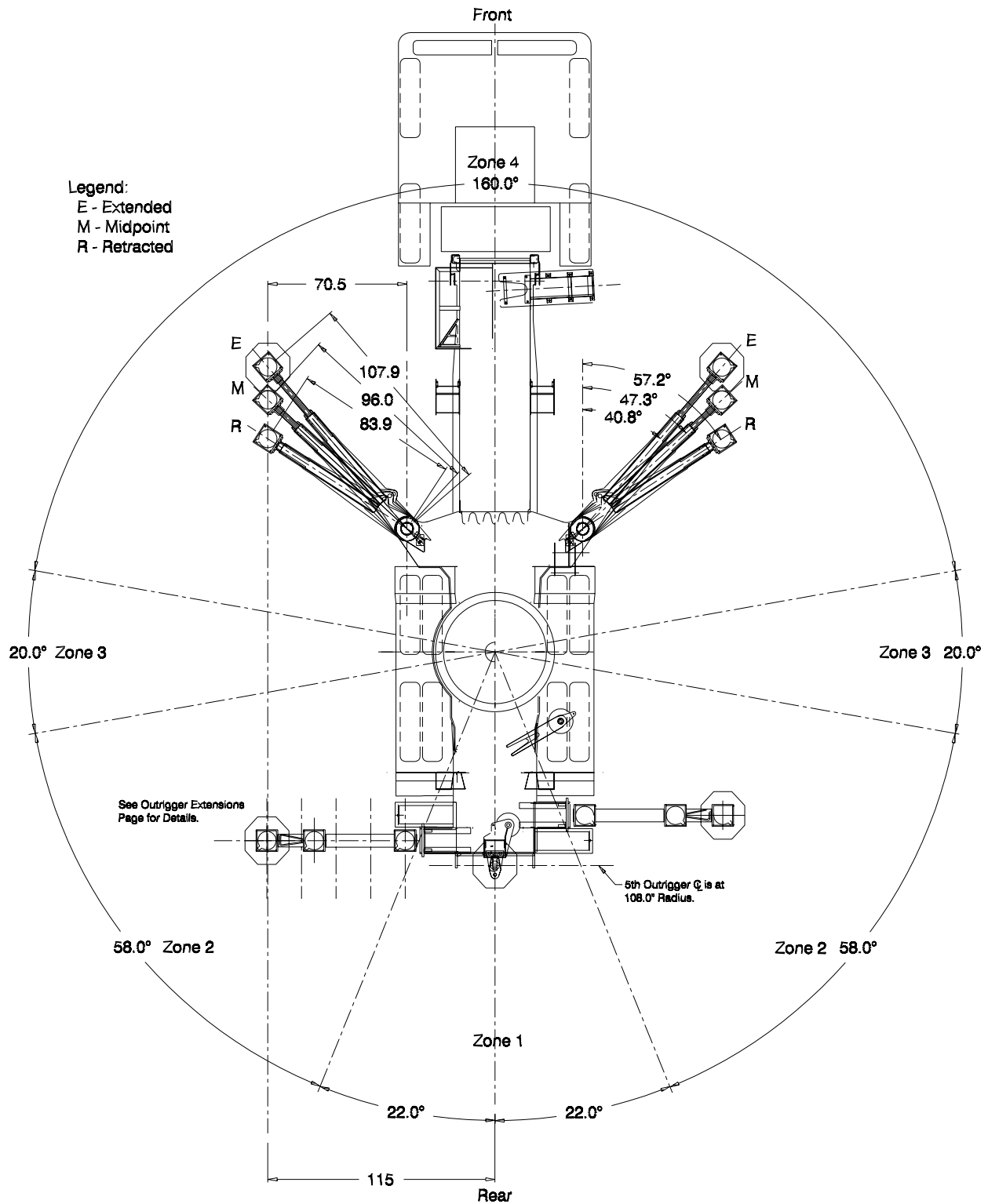

Outrigger Extensions, MANTIS Railroad Rerailer Model 30011

