

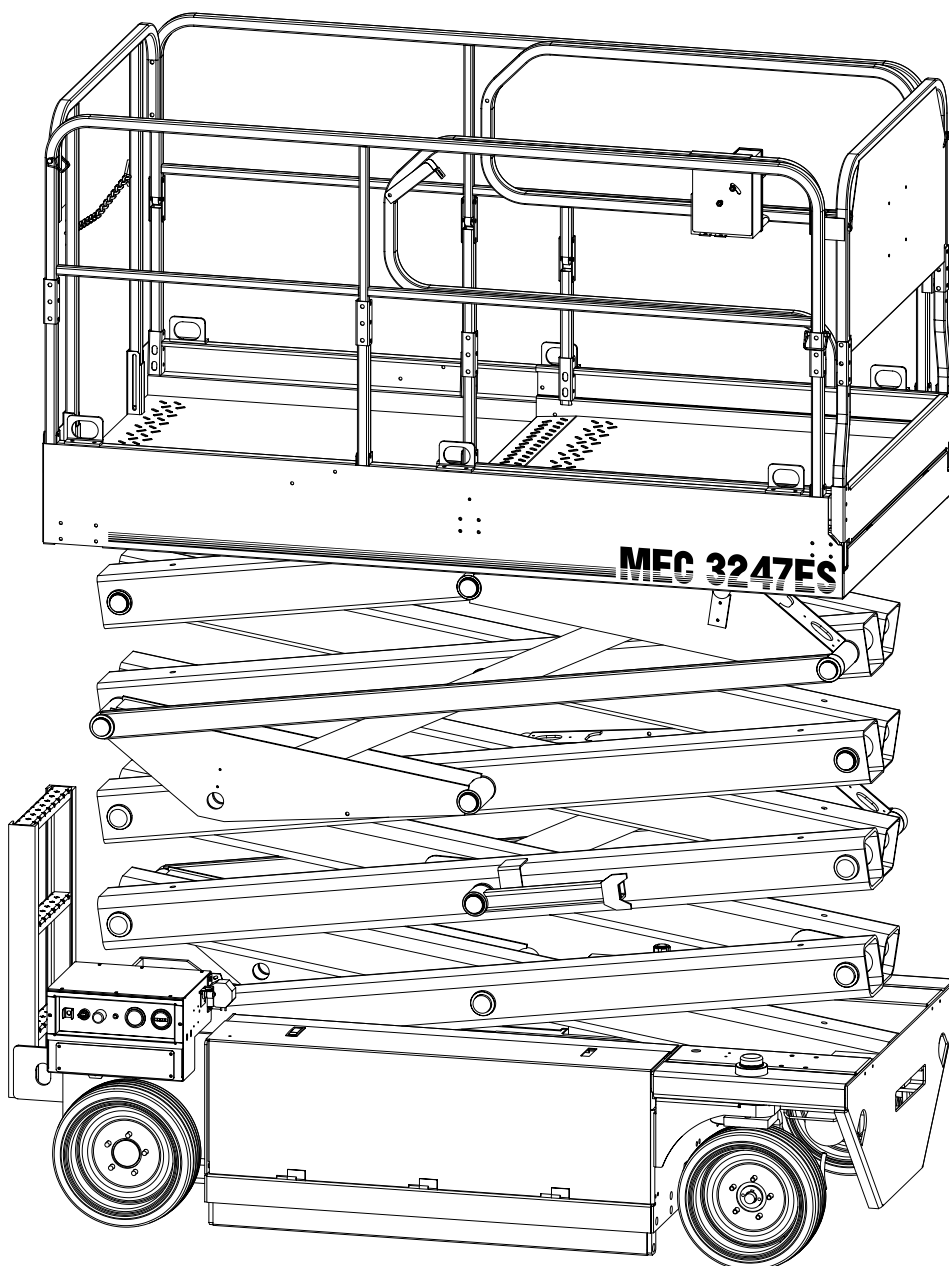

# 2047ES / 2647ES / 3247ES

## OPERATOR'S MANUAL

This Operator's Manual  
**MUST BE READ AND UNDERSTOOD**  
prior to operating your  
MEC Aerial Work Platform



Part # 90908  
Issued July 2005

Serial Number Range  
3247ES: 10001000 - Present  
2647ES: 99011000 - Present  
2047ES: 98011000 - Present



# TABLE OF CONTENTS

Introduction .....	iii
Machine Specifications .....	iv
<b>Section 1: Safety</b>	
Safety Symbols .....	1-2
Safety Rules And Precautions .....	1-3
Fall Protection Notice .....	1-5
Safety And Control Decal Locations - Battery Side .....	1-6
Safety And Control Decal Locations - Hydraulic Side .....	1-7
<b>Section 2: Operation</b>	
Unloading Procedures .....	2-2
Primary Machine Components .....	2-3
Operator Controls .....	2-4
Base Controls .....	2-4
Platform Controls .....	2-6
Platform Controls .....	2-7
Prestart Inspection .....	2-8
Machine Start Up .....	2-8
Base Control Operation And Checks .....	2-9
Platform Control Operation and Checks .....	2-10
Operation .....	2-11
Driving and Steering .....	2-11
Braking .....	2-12
Elevating The Platform .....	2-12
Using Platform Controls .....	2-12
Using Base Controls .....	2-12
Lowering The Platform .....	2-12
Using Platform Controls .....	2-12
Using Base Controls .....	2-12
Extending The Roll-out Extension Deck .....	2-13
Charging The Batteries .....	2-13
Shutdown Procedure .....	2-14
Moving The Machine .....	2-14
Towing/ Winching The Machine .....	2-14
Emergency Systems And Procedures .....	2-16
Emergency Lowering -2047ES and 2647ES .....	2-17
Emergency Lowering - 3247ES .....	2-18

**Section 3: Maintenance**

General Maintenance Tips ..... 3-2  
Prestart Inspection ..... 3-4  
Frequent Inspection ..... 3-6  
Annual Inspection ..... 3-7  
Troubleshooting ..... 3-9  
    What to Check if Functions Will Not Operate ..... 3-9  
Lubrication Diagram ..... 3-10  
Lubrication Chart ..... 3-11

**Limited Owner Warranty**



# INTRODUCTION

This Operator's Manual has been designed to provide you, the customer, with the instructions and operating procedures essential to properly and safely operate your MEC Self-Propelled Scissors for its intended purpose of positioning personnel, along with their necessary tools and materials to overhead work locations.



**THE OPERATOR'S MANUAL MUST BE READ AND UNDERSTOOD PRIOR TO OPERATING YOUR MEC SELF-PROPELLED SCISSORS. THE USER/OPERATOR SHOULD NOT ACCEPT OPERATING RESPONSIBILITY UNTIL HE/SHE HAS READ AND UNDERSTANDS THE OPERATOR'S MANUAL, UNDERSTANDS THEIR RESPONSIBILITIES SET FORTH IN THE ANSI MANUAL OF RESPONSIBILITIES PROVIDED WITH THIS LIFT, AS WELL AS HAVING OPERATED THE MEC SCISSOR LIFT UNDER SUPERVISION OF AN AUTHORIZED, TRAINED AND QUALIFIED OPERATOR.**

**MODIFICATIONS OF THIS MACHINE FROM THE ORIGINAL DESIGN AND SPECIFICATIONS WITHOUT WRITTEN PERMISSION FROM MEC ARE STRICTLY FORBIDDEN. A MODIFICATION MAY COMPROMISE THE SAFETY OF THE MACHINE, SUBJECTING OPERATOR(S) TO SERIOUS INJURY OR DEATH.**

Your MEC Scissor Lift has been designed, built, and tested to provide safe, dependable service. Only authorized, trained and qualified personnel should be allowed to operate or service the machine.

MEC, As Manufacturer, Has No Direct Control Over Machine Application And Operation. Proper Safety Practices Are The Responsibility Of The User And All Operating Personnel.

**If There Is A Question On Application And/Or Operation Contact:**



**MEC Aerial Platform Sales Corp**

1775 Park Street Suite 77 • Selma, CA 93662 USA

Ph: 1-866-379-7278 • Fax: 1-559-263-9631

E-mail: [info@mecawp.com](mailto:info@mecawp.com) • Web: [www.mecawp.com](http://www.mecawp.com)



# MACHINE SPECIFICATIONS

	2047ES		2647ES		3247ES	
Working Height*	<b>26 ft.</b>	8.10m	<b>32 ft.</b>	9.92m	<b>38 ft.</b>	11.75m
Platform Height	<b>20 ft.</b>	6.10m	<b>26 ft.</b>	7.92m	<b>32 ft.</b>	9.75m
Stowed Height:	<b>82.6 in.</b>	2.10m	<b>88.8 in.</b>	2.26m	<b>95.1 in.</b>	2.42m
Folded Down Rails	<b>63.8 in.</b>	1.62m	<b>70.0 in.</b>	1.78m	<b>76.3 in.</b>	1.94m
Maximum Number of Occupants	<b>3</b>		<b>3</b>		<b>2</b>	
Lift Capacity (Evenly Distributed):	<b>1,250 lbs.</b>	567kg	<b>1,000 lbs.</b>	454kg	<b>700 lbs.</b>	317kg
Roll-out Deck Capacity	<b>250 lbs.</b>	113kg	<b>250 lbs.</b>	113kg	<b>250 lbs.</b>	113kg
Platform Dimensions:						
With Roll-Out Deck Extended			<b>133.5 in.</b>	3.39m		
With Roll-Out Deck Retracted			<b>91 in.</b>	2.31m		
Guard Rail Height			<b>42 in.</b>	1.06m		
Toe Board Height			<b>6 in.</b>	15.2cm		
Roll-out Deck Length			<b>42.1 in.</b>	1.07m		
Overall Length			<b>8.25 ft.</b>	2.31m		
Overall Width			<b>47 in.</b>	1.19m		
Wheel Base			<b>71 in.</b>	1.80m		
Wheel Track			<b>41 in.</b>	1.04m		
Turning Radius:						
Inside			<b>0 in.</b>	0cm		
Outside			<b>94 in.</b>	2.4m		
Ground Clearance			<b>3.5 in.</b>	8.9cm		
Machine Weight** (Unloaded) (Approx.)	<b>4,450 lbs.</b>	2018kg	<b>5,120 lbs.</b>	2323kg	<b>5,790 lbs.</b>	2627kg
Drive System (Proportional):						
Drive Speed (Platform Elevated)			<b>0 - 0.5 mph</b>	0 - .80km/h		
Drive Speed (Platform Lowered)			<b>0 - 2.0 mph</b>	0 - 3.2km/h		
Lift/Lower Speed (Approx.)			<b>55/45 sec.</b>	55/45sec.		
Gradeability	<b>25%</b>	25%	<b>22%</b>	22%	<b>20%</b>	20%
Ground Pressure/Wheel (Maximum)	<b>180 psi</b>	12.7kg/cm <sup>2</sup>	<b>194 psi</b>	13.6kg/cm <sup>2</sup>	<b>205 psi</b>	14.4kg/cm <sup>2</sup>
Wind Speed (Maximum)			<b>0 mph</b>	0km/h		
Tire Size-Standard (Solid, non-marking rubber)			<b>16 in D x 5 in. W</b>	40.6cm D x 12.7cm W		
Tire Pressure (Not Applicable For Foam Tires)	<b>N/A</b>					
Wheel Lug Nut Torque			<b>75-85 ft lbs</b>	102-115 Nm		
Hydraulic Pressure:						
Main System	<b>2750 psi</b>	190 bar	<b>2750 psi</b>	190 bar	<b>2750 psi</b>	190 bar
Lift System	<b>2500 psi</b>	172.4 bar	<b>2500 psi</b>	172.4 bar	<b>2050 psi</b>	141 bar
Steer	<b>900 psi</b>	62 bar	<b>900 psi</b>	62 bar	<b>900 psi</b>	62 bar
Hydraulic Fluid Capacity			<b>4.5 gal</b>	17.0 liters		
Fuel Capacity	<b>N/A</b>					
Power System – Voltage	<b>24 Volts DC</b>					
Battery Charger						
Input	110-220 Volt AC, 50/60 Hz, 5.6 Amp					
Output	24 Volt DC, 25 Amps Tapering, Timed Shutoff					
Batteries	Four 6 Volt deep-cycle; 220 Amp hours @ 20 hour rating					
Electric Motor	2.0 h.p. (1.49 kW); 3000 r.p.m.					
Meets Requirements of ANSI A92.6-1999 Section 4						
*Metric equivalent of working height adds 2m to platform height. U.S. adds 6 ft. to platform height.						
**Weight may increase with certain options or country standards.						





**SECTION 1:  
SAFETY**



# SAFETY SYMBOLS

This section of the manual contains important information of the safe use of your MEC Scissors. Failure to read, understand, and follow all safety rules, warnings, and instructions will unnecessarily expose you and others to dangerous situations. For your safety and the safety of those around you, you must operate your machine as instructed in this manual.

You, the operator, are the single most important factor for safety when using any piece of equipment. Learn to operate your machine in a safe manner.

To help you recognize important safety information, we have identified warnings and instructions that directly impact on safety with the following signals:



**“DANGER” INDICATES AN IMMINENTLY HAZARDOUS SITUATION WHICH, IF NOT AVOIDED, WILL RESULT IN DEATH OR SERIOUS INJURY. THIS SIGNAL WORD IS LIMITED TO THE MOST EXTREME SITUATIONS.**



**“WARNING” INDICATES A POTENTIALLY HAZARDOUS SITUATION WHICH, IF NOT AVOIDED, COULD RESULT IN DEATH OR SERIOUS INJURY.**



“CAUTION” indicates a potentially hazardous situation which, if not avoided, may result in minor or moderate injury. It may also be used to alert against unsafe practices. “CAUTION” is used for property-damage only accidents.



# SAFETY RULES AND PRECAUTIONS

- ◆ MEC designs self-propelled scissor lifts to be safe and reliable. They are intended to position personnel, along with their necessary tools and materials to overhead work locations.
- ◆ The owner/user/operator of the machine should not accept responsibility for the operation of the machine, unless properly trained.
- ◆ ANSI A92.6 and other applicable standards identify requirements of all parties who may be involved with self-propelled elevating work platforms. The A92.6 Manual of Responsibilities is considered a part of this machine and can be found in the manual compartment, located at the platform control station.
- ◆ To insure safe use of machine, inspections specified in Section 6.7 of ANSI A92.6-1999 must be performed at designated intervals as prescribed by ANSI A92.6-1999.



- ◆ **ELECTROCUTION HAZARD!!! THIS MACHINE IS NOT INSULATED!!**
- ◆ Maintain safe clearance from electrically charged conductors (power lines) and apparatus. You must allow for machine sway (side to side movement) when elevated and electrical line movement. This machine does not provide protection from contact with, or proximity to, an electrically charged conductor.
- ◆ You must maintain a CLEARANCE OF AT LEAST 10 FEET (3.05 m) between any part of the machine, or its load, and any electrical line or apparatus carrying over 300 volts up to 50,000 volts. One foot (30.5 cm) additional clearance is required for every additional 30,000 volts.
- ◆ DEATH OR SERIOUS INJURY will result from contact with or inadequate clearance from any electrically charged conductor.
- ◆ Only authorized, trained and qualified personnel should operate the scissor lift.
- ◆ NEVER fasten fall protection lanyard to an adjacent structure while on the platform.
- ◆ Make sure that the platform entry is properly closed and secure before operating machine from the platform.
- ◆ NEVER exceed platform rated capacity. Review the section titled "Machine Specifications" (earlier in this manual) regarding model capacities and dimensions.



- ◆ Before operating the machine, read and understand all safety and control information found on the machine and in this manual.
- ◆ When operating the machine follow all safety and control information found on the machine and in this manual.
- ◆ Evenly distribute loads placed on the platform.
- ◆ NEVER use scaffolding, ladders or similar items to extend your reach while on the platform.
- ◆ NEVER climb down the beam assembly while the platform is raised.
- ◆ The “Moving the Machine” section (described later in this manual) requires that the brake be released. After performing this procedure, there is no means to stop the machine’s travel. MEC recommends using this procedure only in cases of emergency, and only for a short distance. Be on guard against machine runaway on sloping surfaces. Movement speed shall not exceed 5 MPH (8.0 kph).
- ◆ NEVER attempt to open any hydraulic line or component without first relieving all system pressure.
- ◆ NEVER alter, modify, or disable any safety devices or interlocks.
- ◆ NEVER recharge the battery near sparks or open flames. Lead-acid batteries generate EXPLOSIVE HYDROGEN GAS. Always wear safety glasses.
- ◆ NEVER use the machine outdoors during electrical storms or in high wind situations.
- ◆ Only raise the platform when the machine is on a firm, level surface.
- ◆ SECURE all tools and other loose items to prevent injury to persons working on or below the platform.
- ◆ Precautions should be taken to prevent unauthorized personnel from operating the platform with the ground controls while the platform is in use.



- ◆ Before disengaging or disconnecting hydraulic motors with brake assembly from a towing vehicle, ensure that the machine cannot roll.
- ◆ Complete the “Operational Checklist” at designated intervals.



- ◆ Use of scissor lift as a crane to lift oversized or hanging loads is prohibited.
- ◆ Always check route and areas are clear before driving, lifting or lowering.
- ◆ It is recommended to avoid sudden braking or steering. Go slowly and leave more maneuvering room during cold weather operation.

## FALL PROTECTION NOTICE

The **Guardrail** System around the perimeter of the platform is the **fall protection system** for self-propelled elevating work platforms per the American National Standards Institute ANSI/SIA A92.6 Standard. It is **prohibited** to use an Aerial Work Platform manufactured by MEC with any portion, or all, of the guardrails **removed**.

Lanyard anchorage points on this type of equipment are not required to conform to the applicable ANSI/SIA Standard.



### THE IMPROPER USE OF FALL ARREST SYSTEMS MAY CAUSE MACHINE TO TIP RESULTING IN SERIOUS INJURY OR DEATH.

However, if anchorage points for lanyard attachments are required by site authorities or other regulations, the anchorage points on all equipment manufactured by MEC are recommended to be used for **work positioning restraints** of personnel only. Lanyard lengths are to be determined by operator/owner to restrict the operator to the confines within the **Guardrail** System.

# SAFETY AND CONTROL DECAL LOCATIONS - BATTERY SIDE

8402

9623 (2047ES)

**MEC 2047ES**

90719



9624 (2647ES)

**MEC 2647ES**

9625 (3247ES)

**MEC 3247ES**

9947 (3247ES)

PLATFORM CAPACITY  
700 LBS (318kg)

9932 (2647ES)

PLATFORM CAPACITY  
1000 LBS (454kg)

9933 (2047ES)

PLATFORM CAPACITY  
1250 LBS (568kg)

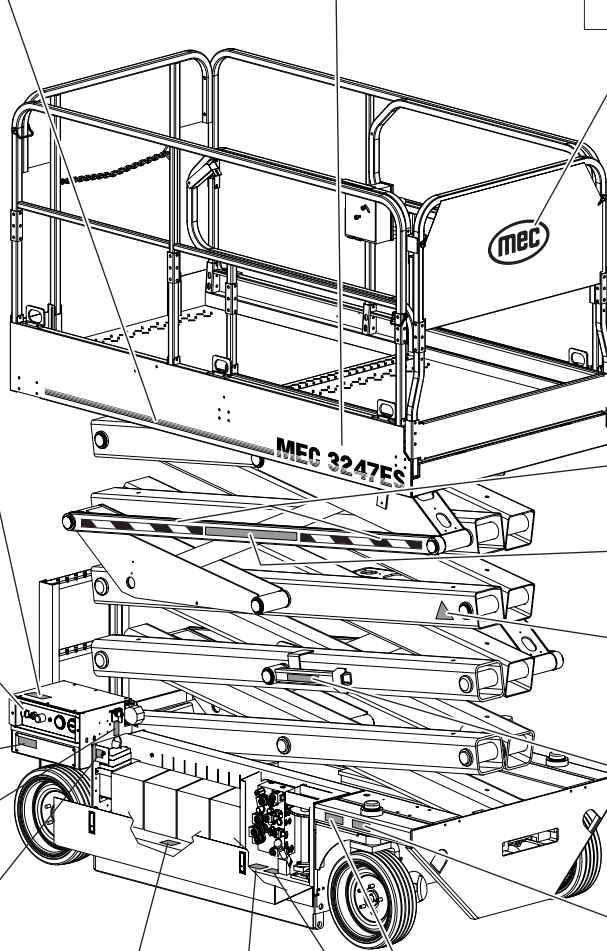

7982



90263

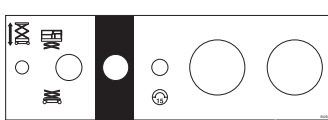

8503

**KEEP CLEAR**

9910



90732



90717

**MAINTENANCE LOCK**  
REFER TO PARTS AND SERVICE  
MANUAL FOR PROPER USE

9052

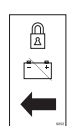

90725

**WARNING**

- REPLACE TIRES WITH MANUFACTURER'S EQUIPMENT ONLY.
- FAILURE TO USE MANUFACTURER'S TIRES MAY CAUSE MACHINE INSTABILITY.
- REFER TO SERVICE AND PARTS MANUAL FOR REPLACEMENT PART NUMBER.

90726

**WARNING**

- EACH REPLACEMENT BATTERY MUST WEIGH A MINIMUM OF 60 POUNDS / 27.3 kg
- FAILURE TO MEET MINIMUM WEIGHT REQUIREMENT MAY CAUSE MACHINE INSTABILITY

90918 (INSIDE)  
(3247ES)



8779 (INSIDE)



90727 (INSIDE)  
(2047ES/2647ES)

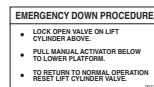

90267 (INSIDE)



# SAFETY AND CONTROL DECAL LOCATIONS - HYDRAULIC SIDE

90722

**WARNING**

INSPECT MACHINE AND MAKE SURE THAT IT IS OPERATING PROPERLY, THAT ALL NAME PLATE AND SAFETY AND CONTROL DECALS ARE IN PLACE AND LEGIBLE, AND THAT THE MACHINE IS IN ACCORDANCE WITH THE MANUFACTURER'S MAINTENANCE REQUIREMENTS CONTAINED IN THE OPERATION AND MAINTENANCE MANUAL AND THE DAILY SAFETY CHECKLIST.

OPERATE MACHINE WITH EXTREME CAUTION. WATCH FOR OBSTRUCTIONS WHICH MAY STRIKE PERSONNEL, CONTROLS, OR MACHINE. OPERATE CONTROLS SLOWLY FOR SMOOTH PLATFORM MOTION.

FOR DRIVING ON ANY GRADE OR SIDE SLOPE:

- PLATFORM MUST BE FULLY LOWERED.
- DO NOT REAR DRIVE PLATFORM ON GRADE.
- DO NOT DRIVE ON GRADE OR SIDE SLOPE.
- DO NOT DRIVE ON SIDE SLOPE OF DRIVE OFF.

FOR DRIVING WITH PLATFORM ELEVATED:

- DRIVE ONLY ON GRADE, FIRM AND LEVEL.
- SURFACE AREA OF OBSTRUCTIONS.
- DO NOT REAR DRIVE PLATFORM ON GRADE.
- EXTENSION LINE CAPACITY.
- LOOK AHEAD FOR OBSTRUCTIONS.
- USE EXTREME CAUTION.

IMPROPER OPERATION OF THIS MACHINE COULD CAUSE DEATH OR SERIOUS INJURY.

90721

**WARNING**

**YOU MUST NOT OPERATE THIS MACHINE:**

- UNLESS YOU HAVE BEEN AUTHORIZED TO USE AND TRAINED IN THE SAFE OPERATION OF THIS MACHINE.
- UNLESS YOU HAVE READ AND UNDERSTOOD THE SAFETY AND OPERATION INSTRUCTIONS CONTAINED IN THE MANUFACTURER'S MANUAL.
- UNLESS YOU HAVE BEEN ADVISED BY AN AUTHORIZED SERVICE PERSONNEL.
- UNLESS YOU HAVE BEEN ADVISED BY AN AUTHORIZED SERVICE PERSONNEL.

**TIP-OVER HAZARDS**

- DO NOT DRIVE NEAR HOOP-OFFS, HILLS, OPEN ELEVATION EDGES, AND GRADING SLOPES.
- DO NOT ELEVATE PLATFORM ON OBSTRUCTIONS.
- DO NOT DRIVE ON SLOPE OR DRIVE OFF ONTO SLOPE WHEN ELEVATED.
- DO NOT BASE PLATFORM ON SLOPE OR DRIVE OFF ONTO SLOPE WHEN ELEVATED.
- DO NOT BASE PLATFORM IN WINDY OR GUSTY CONDITIONS.

**ELECTROCUSSION HAZARD**

THIS MACHINE IS NOT INSULATED. HAZARDOUS CLEARANCE FROM ELECTRICAL LINES AND APPARATUS. YOU MUST ALLOW FOR MACHINE WIRE BUCK OR BULB AND ELECTRICAL LINES SPACING.

THIS MACHINE DOES NOT PROVIDE PROTECTION FROM CONTACT WITH OR PROXIMITY TO AN ELECTRICALLY CHARGED CONDUCTOR.

FROM REAR, MAINTAIN A CLEARANCE OF AT LEAST TEN (10) FEET BETWEEN ANY PART OF THE MACHINE AND ANY ADDITIONAL ELECTRICAL LINE OR APPARATUS CARRYING UP TO 600 VOLTS, ONE FOOT OF ADDITIONAL CLEARANCE IS REQUIRED FOR OVERVOLTAGE ADDITIONAL 3000 VOLTS OR LESS.

DEATH OR SERIOUS INJURY WILL RESULT FROM CONTACT OR INADEQUATE CLEARANCE.

DEATH OR SERIOUS INJURY WILL RESULT FROM IMPROPER USE OF THIS EQUIPMENT.

90729

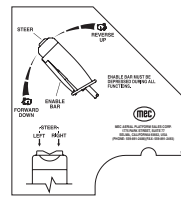

90735

IF UNIT DOES NOT DRIVE DURING ELEVATION, CHECK FOR OBSTRUCTION UNDER OR AGAINST AUTOMATIC POTHOLE STABILIZERS

7156



8391

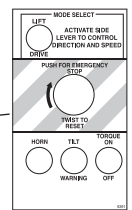

90723

**WARNING**

- AMBER LIGHT INDICATES UNSAFE LEVEL CONDITION
- LOWER PLATFORM AND REPOSITION MACHINE BEFORE ELEVATING AGAIN

90733



90741

THIS CONTROL BOX TO BE USED WITH MEC 1532ES, 1932ES, 2033ES, 2633ES AND 47ES MODELS ONLY

90730

**WARNING**

- PLATFORM EXTENSION MUST BE LOCKED IN PLACE AT ALL TIMES.
- DO NOT OPERATE PLATFORM WITH EXTENSION LINE CAPACITY.
- PLATFORM ENTRANCE MUST BE PROPERLY CLOSED AND ALL CLEARANCE IS REQUIRED FOR OVERVOLTAGE ADDITIONAL 3000 VOLTS OR LESS.

90718 INSIDE CASE

**WARNING**

USE OR OPERATION OF AN UNSUPPORTED WORK PLATFORM COULD CAUSE DEATH OR SERIOUS INJURY.

NEW	1ST YEAR	2ND YEAR	3RD YEAR	4TH YEAR	5TH YEAR
DO NOT OPERATE THIS WORK PLATFORM IF AN INSPECTION HAS NOT BEEN PERFORMED WITHIN 12 MONTHS OF THE LAST RECORDED INSPECTION DATE.	18TH YEAR	18TH YEAR	18TH YEAR	18TH YEAR	18TH YEAR
STAMP MONTHLY/DAILY YEAR NEXT TO APPROPRIATE YEAR AFTER EACH INSPECTION.					
CHANGE OF OWNERSHIP OF THIS WORK PLATFORM MUST BE REPORTED TO MANUFACTURER.					

9947 (3247ES)

PLATFORM CAPACITY 700 LBS (318kg)

9932 (2647ES)

PLATFORM CAPACITY 1000 LBS (454kg)

9933 (2047ES)

PLATFORM CAPACITY 1250 LBS (568kg)

7155

LOCATE CONTROL BOX HERE  
← FOR NORMAL OPERATION OF THIS UNIT

9623 (2047ES)



9624 (2647ES)



9625 (3247ES)



8402



8599 (2047ES/2647ES)

PULL AND TURN KNOB TO LOCK VALVE OPEN

7982



8503

KEEP CLEAR

6873

HYDRAULIC OIL

9910



90826

BATTERY CHARGER INDICATOR

0%	25%	50%	75%	100%
OK	OK	OK	OK	OK
OK	OK	OK	OK	OK
OK	OK	OK	OK	OK

90747

SERIAL NUMBER PLATE

6556

FORK LIFT POCKETS

90739



8779

**WARNING**

BATTERIES PRODUCE EXPLOSIVE GAS. CHARGE BATTERIES IN WELL VENTILATED AREA. DO NOT EXPOSE TO SPARKS OR FLAMES.

90751

POWER TO PLATFORM

90750

BATTERY CHARGER

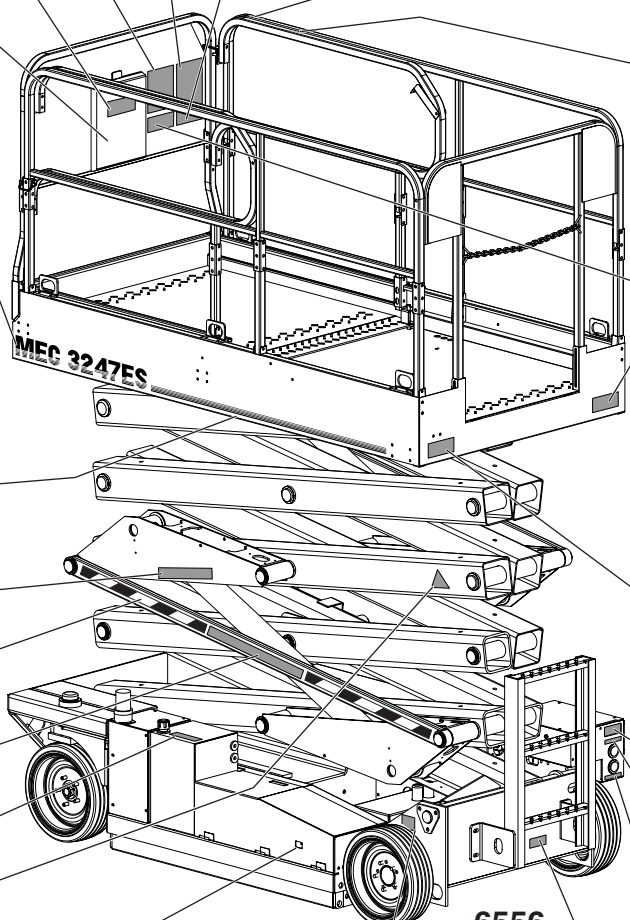



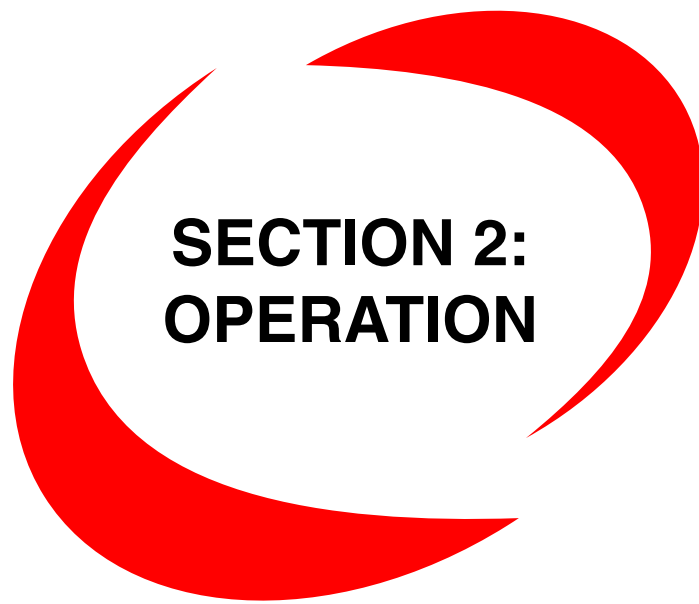
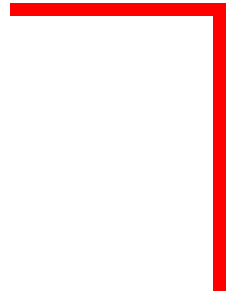

# **SECTION 2: OPERATION**

# UNLOADING PROCEDURES

- ◆ Inspect the outside of the machine for damage. Inspect all hoses, beam assemblies (armset), and cables for chafing or road damage. Confirm that all wheel lug nuts are tight (refer to the “Machine Specifications”).
- ◆ Unlock and open side compartments. Inspect all electrical and hydraulic connections for damage and security.
- ◆ Turn battery switch to ON position. Check electrolyte level.
- ◆ Check engine oil level and add as required per engine manufacturer’s recommendations.
- ◆ Check that fluid level is to the fill mark on the hydraulic tank and add fluid as required (see “Lubrication Chart”).
- ◆ Close side compartments.



**ALWAYS ATTACH THE MACHINE TO A WINCH WHEN LOADING OR UNLOADING FROM A TRUCK OR TRAILER IF DRIVEN OFF. WE DO NOT RECOMMEND UNASSISTED LOADING OR UNLOADING OF ANY SCISSOR LIFT.**

**READ AND UNDERSTAND ALL SAFETY, CONTROL, AND OPERATING INFORMATION FOUND ON MACHINE AND IN THIS MANUAL BEFORE OPERATING THE MACHINE.**

- ◆ Attach the machine to a winch for the unloading.
- ◆ Perform Machine Start-up procedures in this section. Refer to Operator Controls Descriptions, as necessary.
- ◆ Remove all machine tie downs. Remove wheel chocks, if used. Turn the Base/ Platform selector switch to the “PLATFORM” position.
- ◆ Enter the platform, activate emergency stop switch (rotate clockwise and release). Test all platform functions.
- ◆ Carefully drive the machine off the truck or trailer with the winch still attached.

**NOTE:** The brakes are automatically released for driving and will automatically apply when the machine stops.

- ◆ **Before placing the machine into service, all operators must read and understand the contents of this Operator’s Manual.**



# PRIMARY MACHINE COMPONENTS

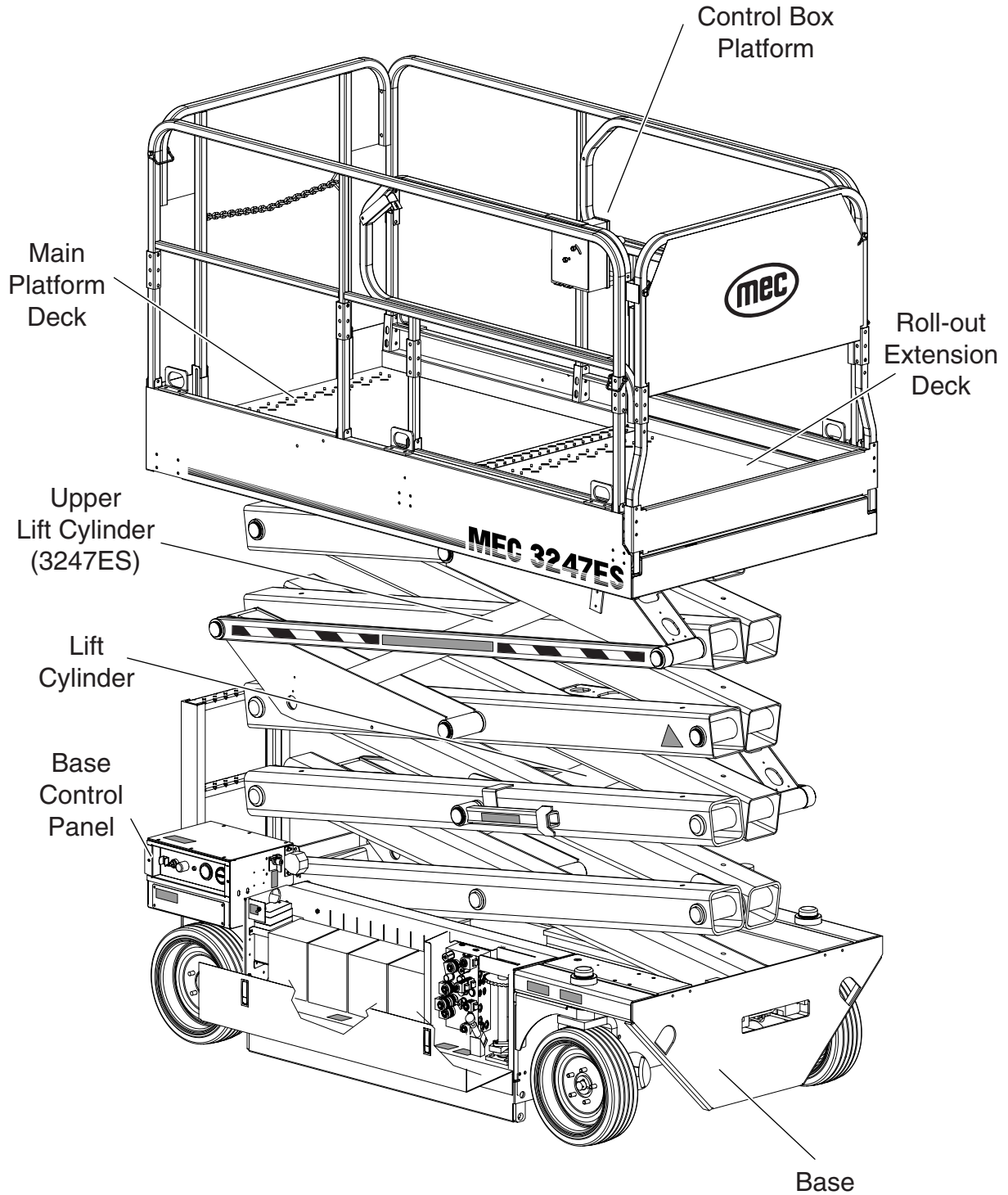

# OPERATOR CONTROLS

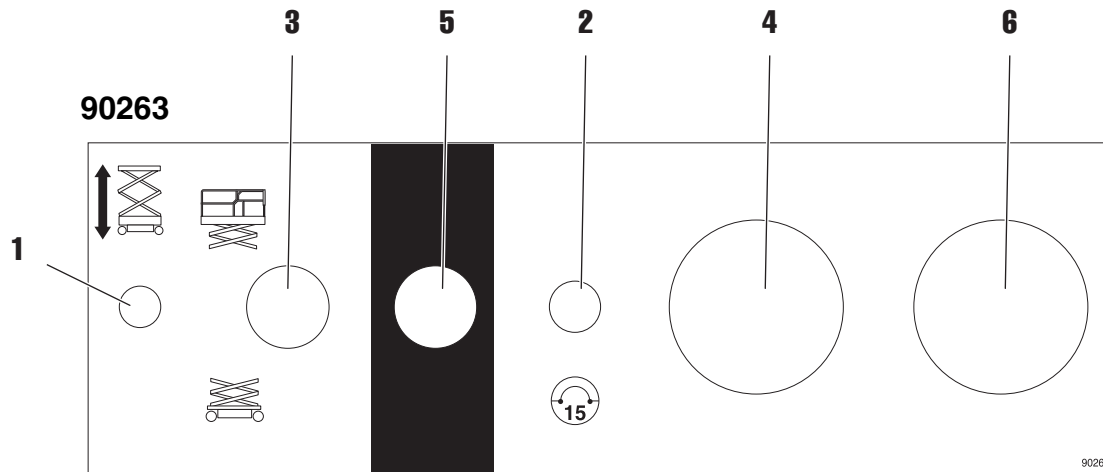





## BASE CONTROLS

CONTROL		DESCRIPTION
1	Lift/Lower Switch	Use to control the lift and lowering of the platform from the base panel, when "BASE" position is selected as the primary control station.
2	Circuit-breaker	Pops out when there is excessive electrical load in the 12-volt control circuit. Push in to reset.
3	Base/Off/Platform Selector Switch	Select "BASE" position to control operation of machine using the base controls. Select "PLATFORM" position to control operation of machine using the platform console. <b>NOTE:</b> A key shall be provided for European machines and will be removable in "PLATFORM" position only.
4	Battery Gauge (Optional)	Indicates percent of charge left in batteries.
5	Emergency Stop Button	Use to stop all functions in an emergency. Push for emergency stop. To reset turn clockwise.
6	Hour Meter	Indicates total elapsed time the machine has been operated.

# OPERATOR CONTROLS (Continued)

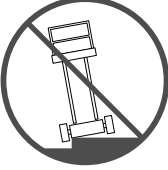
90721

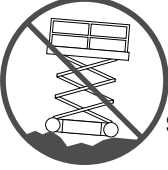
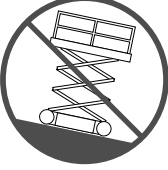
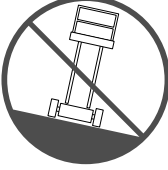
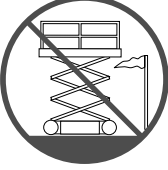
 <h1 style="margin: 0;">DANGER</h1>	
<p><b>YOU MUST NOT OPERATE THIS MACHINE:</b></p> <p>UNLESS YOU HAVE BEEN AUTHORIZED TO USE AND TRAINED IN THE SAFE OPERATION OF THIS MACHINE.</p> <p>TRAINING INCLUDES COMPLETE KNOWLEDGE OF THE SAFETY AND OPERATION INSTRUCTIONS CONTAINED IN THE MANUFACTURERS MANUAL, ANSI MANUAL OF RESPONSIBILITIES, YOUR EMPLOYERS WORK RULES AND APPLICABLE GOVERNMENTAL REGULATIONS.</p> <p>AN UNAUTHORIZED AND UNTRAINED OPERATOR SUBJECTS THEMSELF AND OTHERS TO DEATH OR SERIOUS INJURY.</p>	<p><b>TIP-OVER HAZARDS</b></p> <div style="display: flex; justify-content: space-around;">   </div> <p>DO NOT DRIVE NEAR DROP-OFFS, HOLES OPEN ELEVATOR SHAFTS, AND LOADING DOCKS</p>
 <p><b>ELECTROCUTION HAZARD</b> THIS MACHINE IS NOT INSULATED</p> <p>MAINTAIN SAFE CLEARANCE FROM ELECTRICAL LINES AND APARATUS. YOU MUST ALLOW FOR MACHINE SWAY, ROCK OR SAG AND ELECTRICAL LINES SWAYING.</p> <p>THIS MACHINE DOES NOT PROVIDE PROTECTION FROM CONTACT WITH OR PROXIMITY TO AN ELECTRICALLY CHARGED CONDUCTOR.</p> <p>YOU MUST MAINTAIN A CLEARANCE OF AT LEAST TEN (10) FEET BETWEEN ANY PART OF THIS MACHINE OR ITS LOAD AND ANY ELECTRICAL LINE OR APARATUS CARRYING UP TO 50,000 VOLTS. ONE FOOT OF ADDITIONAL CLEARANCE IS REQUIRED FOR EVERY ADDITIONAL 30,000 VOLTS OR LESS.</p>	 <p>DO NOT ELEVATE PLATFORM ON UNEVEN OR SOFT SURFACES DO NOT DRIVE ONTO UNEVEN OR SOFT SURFACES WHEN ELEVATED</p>
<p>DO NOT RAISE PLATFORM ON SLOPE, OR DRIVE ONTO SLOPE WHEN ELEVATED</p>	  <p>DO NOT RAISE PLATFORM ON SLOPE, OR DRIVE ONTO SLOPE WHEN ELEVATED</p>
<p>DO NOT RAISE PLATFORM IN WINDY OR GUSTY CONDITIONS</p>	 <p>DO NOT RAISE PLATFORM IN WINDY OR GUSTY CONDITIONS</p>
<p><b>DEATH OR SERIOUS INJURY WILL RESULT FROM CONTACT OR INADEQUATE CLEARANCE</b></p>	<p><b>DEATH OR SERIOUS INJURY WILL RESULT FROM IMPROPER USE OF THIS EQUIPMENT</b></p>

90721

# OPERATOR CONTROLS (continued)

## PLATFORM CONTROLS

8391

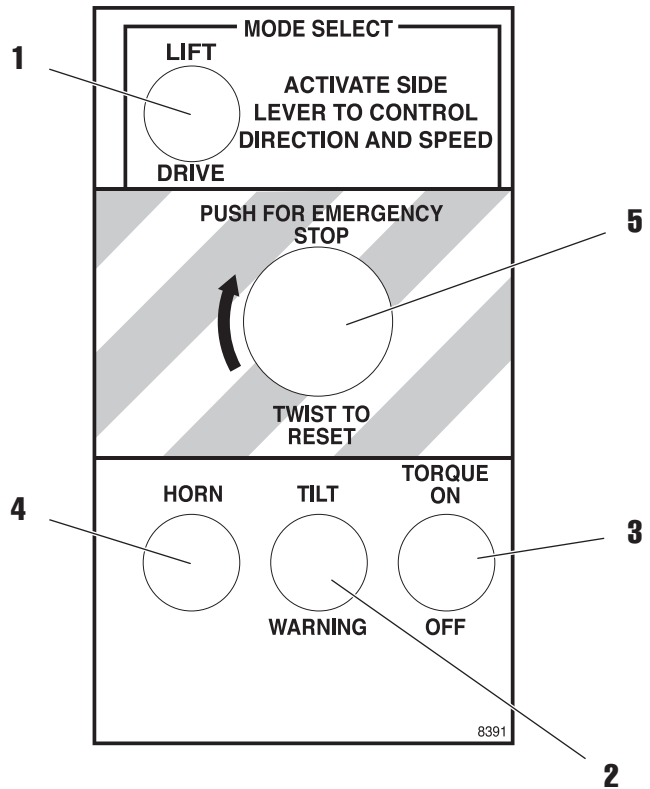

90729

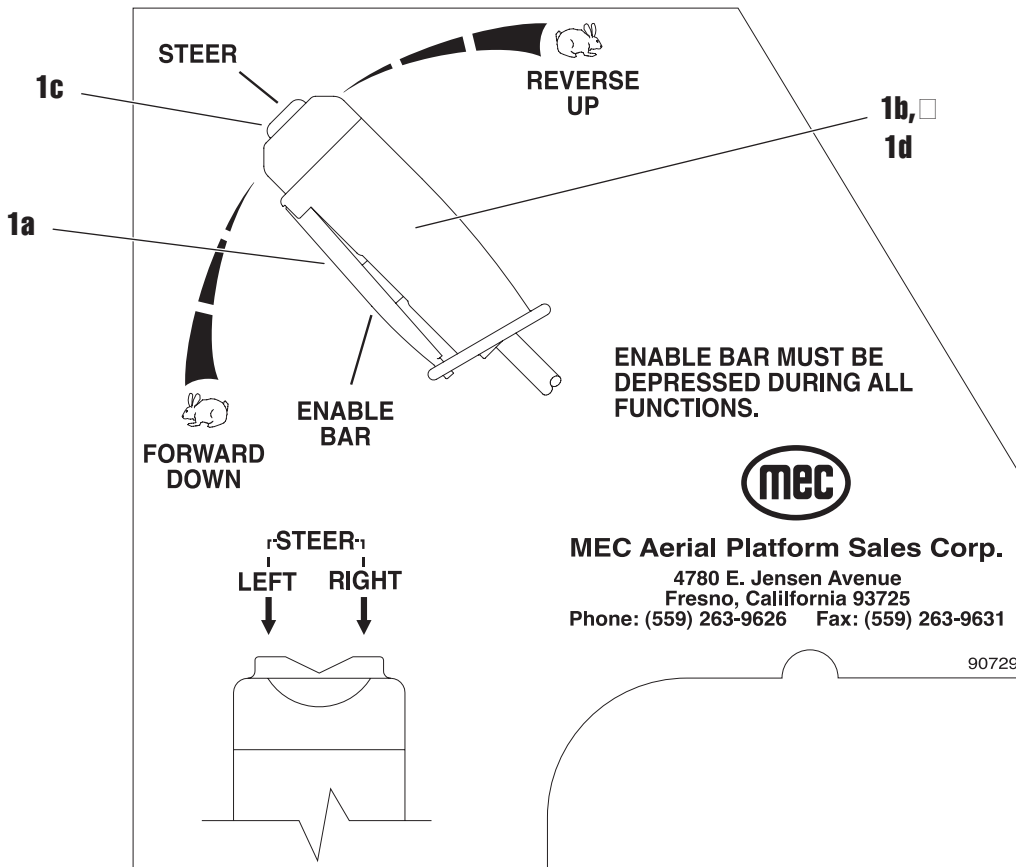

# OPERATOR CONTROLS (continued)

## PLATFORM CONTROLS

CONTROL		DESCRIPTION
1	Mode Selector	Desired selection will allow either the lift or drive function using controller handle.
1a	Enable Bar	Must be depressed to active drive, steer, and lift functions.
1b	“Forward/Reverse”	Controls forward and reverse machine travel at speed proportional to handle movement.
1c	“Left/Right”	Push Steer Rocker Switch (thumb) to the left and hold to turn steer wheels to the left, right to turn steer wheels to the right.
1d	“Lift/Lower” Controller	With enable bar depressed, moving controller handle toward the operator (up) will provide platform lift at a speed proportional to handle movement. Moving the handle away from the operator (down) will provide platform lowering at a fixed speed.
2	Tilt Warning Light	Indicates that machine is not level.
3	Torque On/Off Switch	“ON” selection will provide extra driving torque and reduce drive speed when the platform is under approximately 7 ft (2.13 m). “OFF” position is the normal mode.
4	Horn	Press button to sound warning horn.
5	Emergency Stop Button	Push to stop all functions in emergency. Reset by turning clockwise.

# PRESTART INSPECTION

Before use each day or at the beginning of each shift, the machine shall be given a visual inspection and functional test. Repairs (if any) must be made prior to operating the machine as it is critical to ensure safe operation of the machine.

- ◆ Visually inspect all machine components; for loose or missing parts, hydraulic fluid leaks, loose or damaged wires. Check for structural or weld cracks.
- ◆ Check fluid levels with the platform fully lowered.
- ◆ Check the wheel lug nuts for tightness (Refer to “Machine Specifications”).
- ◆ Check that all warning and instructional labels are legible and secure.
- ◆ Check the platform guard rail system. Insure platform entry properly closes and secures.
- ◆ Ensure that emergency stop buttons on the base control panel and the platform controls are disengaged. Reset by turning clockwise.
- ◆ Ensure that the battery disconnect switch is in the “ON” position.

## MACHINE START UP

1. Ensure the battery disconnect switch, located on Base Control Box, is in the “ON” position.
2. Place the base/platform select switch to the desired position.
3. The machine can now be operated from the selected position.

**NOTE:** If the machine fails to operate, inspect the motor controller inside the motor compartment. A green LED located on the controller should be illuminated. If the LED is not illuminated, refer to the troubleshooting section.



## BASE CONTROL OPERATION AND CHECKS



### ◆ ELECTROCUTION HAZARD!!! THIS MACHINE IS NOT INSULATED!!

Maintain safe clearance from electrically charged conductors (power lines) and apparatus. You must allow for machine sway (side to side movement) when elevated and electrical line movement. This machine does not provide protection from contact with, or proximity to, an electrically charged conductor.



**BE SURE AREA ABOVE THE MACHINE IS CLEAR OF OBSTRUCTIONS TO ALLOW FULL ELEVATION OF PLATFORM.**

**DO NOT OPERATE THE MACHINE IF THE FOLLOWING CHECKS REVEAL A DEFECT.**

- ◆ Turn selector switch to “BASE” position.
- ◆ Activate the Lift/ Lower switch on the base control panel to elevate the platform to the end of its movement. Releasing the switch should stop elevation.
- ◆ Test the “Emergency Stop” function. While the platform is moving, press the Emergency Stop button, platform should stop.
- ◆ Reset by rotating clockwise.
- ◆ Lower the platform about halfway by switching the Lift/ Lower switch. Releasing the switch should stop the lowering.
- ◆ Check for proper operation and hydraulic leaks. Rotate the maintenance lock into position before inspecting any items inside or around scissor arms.
- ◆ Rotate the maintenance lock into position. Lower platform to the stowed position.

## PLATFORM CONTROL OPERATION AND CHECKS

- ◆ Select the “Platform” position on the selector switch at base control station.
- ◆ Enter platform and close and secure the entry.
- ◆ Press the horn button briefly to check if working properly, if installed.

**IMPORTANT: The Enable Bar must be activated to operate the controller for Drive, Steer, and Lift/ Lower Function.**

- ◆ Check for proper operation and hydraulic fluid leaks.
- ◆ Move mode selector switch to “Lift” position, depress Enable bar and move control handle “up” (toward the operator).
- ◆ Test emergency stop function by pressing down on the red Emergency Stop switch. Reset by rotating clockwise.
- ◆ To lower platform, depress the Enable bar and move control handle “down” (away from the operator).



**IF PLATFORM SHOULD FAIL TO LOWER DO NOT ATTEMPT TO CLIMB DOWN THE BEAM ASSEMBLY. SERIOUS INJURY MAY RESULT.**

**IMPORTANT: Always check front steer wheel direction before driving.**

- ◆ Move mode select switch to “Drive” position. Test Left/ Right steering by depressing Enable bar on control handle and pressing the rocker switch at the top of the handle. Press left side of switch for left steer direction and right side for right steer direction.
- ◆ Move the mode select switch to “Drive” position, depress Enable bar and move control handle “forward” and “backward” to check drive direction. Releasing the Enable bar or returning control handle to center position will stop motion of drive.
- ◆ Test the “Emergency Stop” function. While driving in both directions. Reset “Emergency Stop” by rotating the switch clockwise.





# OPERATION



**THE OPERATOR MUST BE AWARE OF THE ENVIRONMENT.  
DO NOT RAISE THE PLATFORM IF THE MACHINE IS NOT ON A  
FIRM LEVEL SURFACE.**

**SAFE OPERATION BEGINS WITH A SAFETY CONSCIOUS  
EQUIPMENT OPERATOR.**

Perform prestart inspection. Remember to place the selector switch in the “Platform” position before getting in the platform for operation.

## DRIVING AND STEERING



**CHECK THAT THE ROUTE OF TRAVEL TO BE TAKEN IS  
CLEAR OF PERSONS, OBSTRUCTIONS, DEBRIS, HOLES, AND  
DROP OFFS, AND IS CAPABLE OF SUPPORTING THE  
MACHINE.**

**NOTE:** To activate drive function, activate mode selector switch in “Drive” position. Depressing the Enable bar, drive and steer functions can be achieved. Steer wheels will not center themselves after a turn, and must be returned to the straight-ahead position with the steer switch.

Controller handle movement “away” from the operator will give FORWARD travel and pulling the handle “towards” the operator will give REVERSE travel.

Travel speed is proportional and is controlled by the movement of the controller handle. The further it is moved the faster the speed will be. The controller handle returns to neutral (center) position when released.

## BRAKING



**ACTIVATION OF THE PLATFORM “EMERGENCY STOP” BUTTON WILL APPLY BRAKES IMMEDIATELY. THIS MAY CAUSE UNEXPECTED PLATFORM MOVEMENT AS THE MACHINE COMES TO A SUDDEN STOP. BRACE YOURSELF AND SECURE OBJECTS ON THE PLATFORM DURING OPERATION OF MACHINE.**

**NOTE:** For parking, the brake is automatically applied when the forward/reverse drive controller is positioned in the center (neutral) position.

## ELEVATING THE PLATFORM

### USING PLATFORM CONTROLS

To elevate the platform, activate mode selector switch in the “Lift” position. Depressing the Enable bar and moving controller handle “towards” the operator will elevate the platform. Rate of lift is proportional and is dependent on the movement of the controller handle.

### USING BASE CONTROLS

With selector switch in the “Base” position, press and hold the Lift/ Lower toggle switch on the base control panel in the “Up” position until the desired height is reached or until the platform reaches maximum height.

## LOWERING THE PLATFORM

### USING PLATFORM CONTROLS

To lower the platform, activate mode selector switch to the “Lift” position. Depressing the Enable bar and moving the controller handle “away” from the operator will lower the platform. Rate of descent is fixed - platform lowers at same rate regardless of handle position.

### USING BASE CONTROLS

With selector switch in the “Base” position, press and hold the Lift/ Lower toggle switch in the “Down” position until the desired platform height is reached or until the platform reaches the stowed position.

## EXTENDING THE ROLL-OUT EXTENSION DECK

- ◆ Lift handle at the rear of the extension deck to raise spring-loaded pin from the locked position.
- ◆ With handle raised, push the deck out to the desired extended length and release the handles for the spring-loaded pin to lock into position.
- ◆ Extensions can be achieved in intervals of 6 inches (15 cm) throughout the entire length of the roll-out extension deck.



**IF THE ROLL-OUT DECK IS EXTENDED CHECK FOR CLEARANCE UNDER DECK AREA BEFORE LOWERING PLATFORM.**

## CHARGING THE BATTERIES



**LEAD-ACID BATTERIES GENERATE EXPLOSIVE GASES. KEEP SPARKS AND FLAME AWAY FROM BATTERIES.**

**NO SMOKING !**

- ◆ Plug the battery charger into 115 volt, 60 Hz AC outlet, using #12 AWG grounded extension cord to recharge the batteries.

To determine if the batteries are fully charged, plug the charger in. The LED indicating 2/3 charge illumination within a few minutes indicates that the batteries are fully charged.



**DO NOT OPERATE THE UNIT WHILE CHARGING.**

**BE SURE TO DISCONNECT THE CHARGER FROM THE OUTLET BEFORE MOVING THE UNIT.**

## SHUTDOWN PROCEDURE

- ◆ When finished with the machine, place the platform in the stowed position.
- ◆ Park the machine on a level surface.
- ◆ Carefully exit the platform using a constant three (3) point dismount/grip.
- ◆ Place selector switch at base control panel in the “Off” position.

**NOTE:** Leaving the selector switch in the base or platform position for an extended time will drain the battery. Always put the selector switch in “Off” position when leaving the machine at the end of the work day.

- ◆ Put a padlock on the battery disconnect switch to prevent unauthorized operation.

## MOVING THE MACHINE

Machine can be winched or moved short distances in case of power failure at speeds not to exceed 5 MPH (8.05 kph).

## TOWING/ WINCHING THE MACHINE

Your machine is equipped with a brake release.



**PRIOR TO MANUALLY RELEASING BRAKES, INSURE WHEELS ARE CHOCKED TO PREVENT MACHINE FROM MOVING.**

Release Brakes Before Towing:

- ◆ Push in the manual brake release valve located on the main manifold.
- ◆ Using the hand pump in the battery compartment, pump valve until pressure is built.
- ◆ Machine is now ready for towing.

## MOVING THE MACHINE (continued)

Manual Brake Release

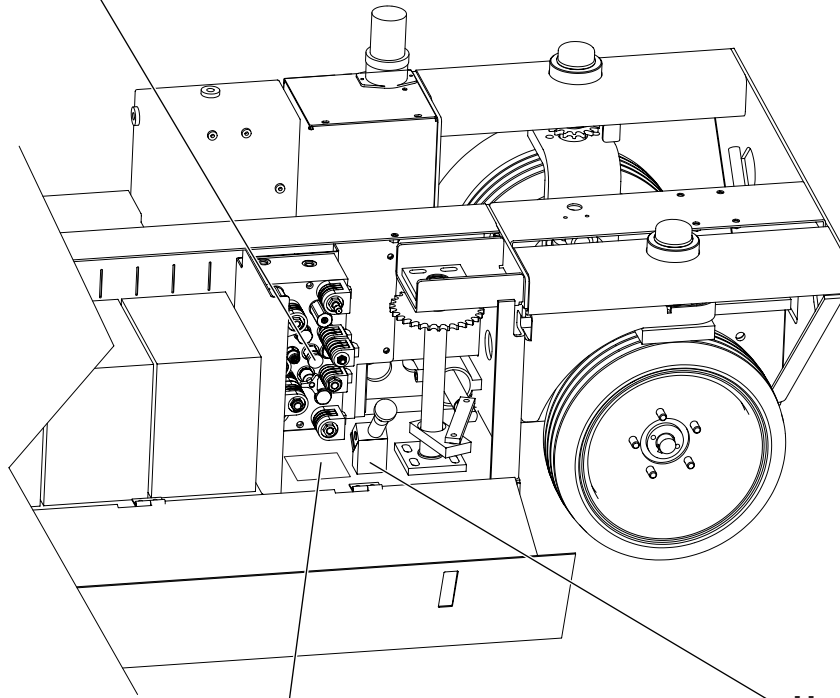

Hand Pump

90267

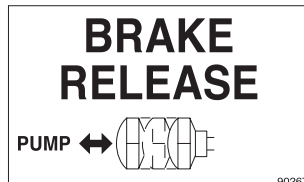

**AFTER RELEASING THE BRAKES, THERE IS NOTHING TO STOP THE MACHINE'S TRAVEL. MACHINE WILL ROLL FREELY ON SLOPES. BE ON GUARD AGAINST RUNAWAY. DO NOT DRIVE MACHINE WITH BRAKES RELEASED.**

To Reset Brakes:

- ◆ Brakes will reset when drive function is activated or reset by pulling on manual brake release valve.

# EMERGENCY SYSTEMS AND PROCEDURES



**IF THE CONTROL SYSTEM FAILS WHILE THE PLATFORM IS ELEVATED, HAVE AN EXPERIENCED OPERATOR USE THE EMERGENCY LOWERING PROCEDURE TO SAFELY LOWER THE PLATFORM.**

**NEVER CLIMB DOWN BEAM ASSEMBLY WHEN PLATFORM IS RAISED.**



**BEFORE LOWERING PLATFORM RETRACT THE DECK EXTENSION.**

## EMERGENCY LOWERING -2047ES AND 2647ES

The Emergency Down System is used to lower the platform in case of power or valve failure. To lower the platform, perform the following steps:

1. Pull and turn knurled knob on lift cylinder counterclockwise to lock the valve in open position.
2. Pull manual activator (override valve) on main manifold to lower platform to desired height.
3. To return to normal operation, turn knurled knob on lift cylinder clockwise. Valve will automatically lock.

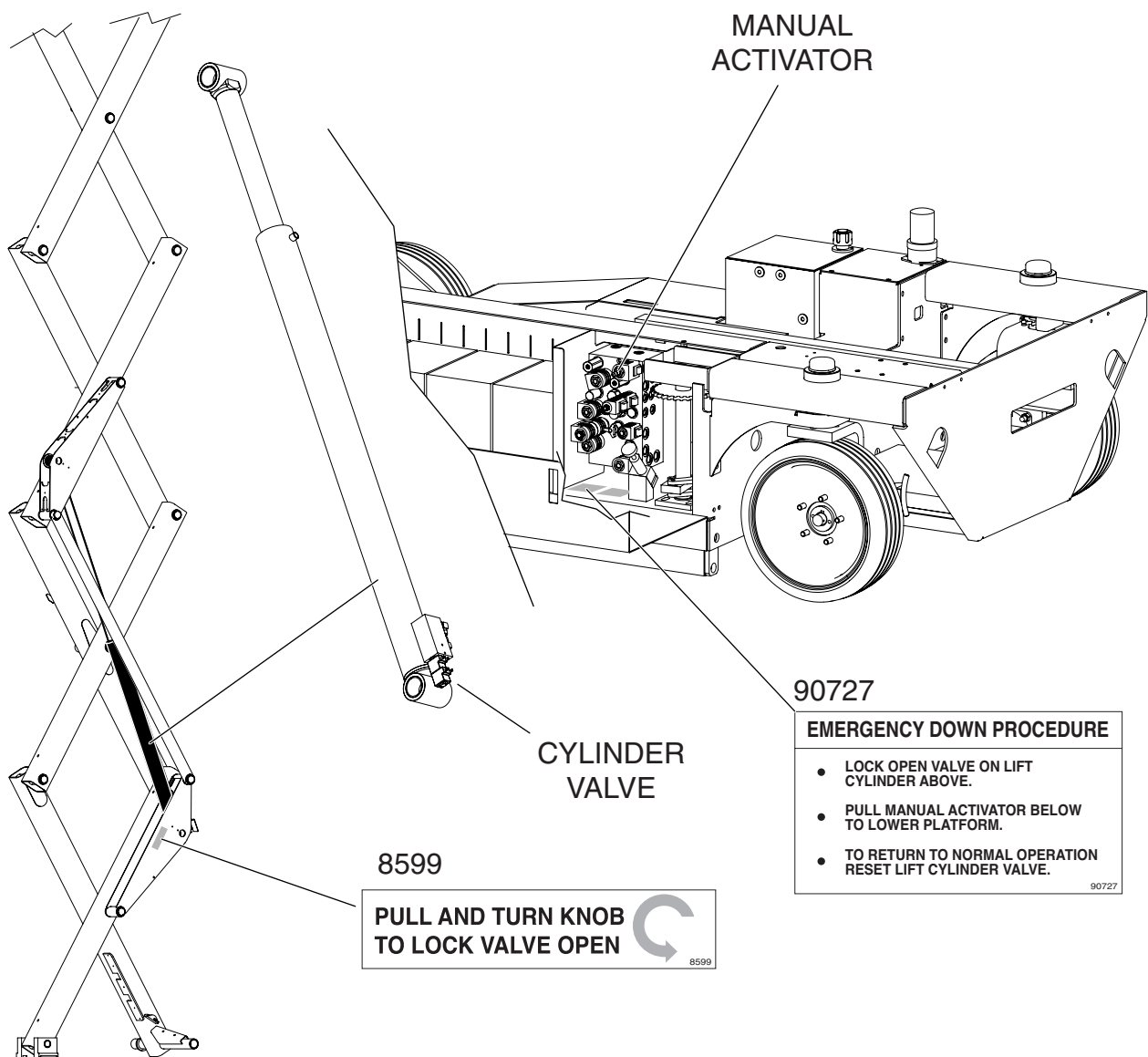

## EMERGENCY LOWERING - 3247ES

The Emergency Down System is used to lower the platform in case of power or valve failure. To lower the platform, perform the following steps:

1. Push down on the toggle switch and hold it to lower the platform to the desired height.
2. Once the platform is fully lowered, release the toggle switch to close the valve.

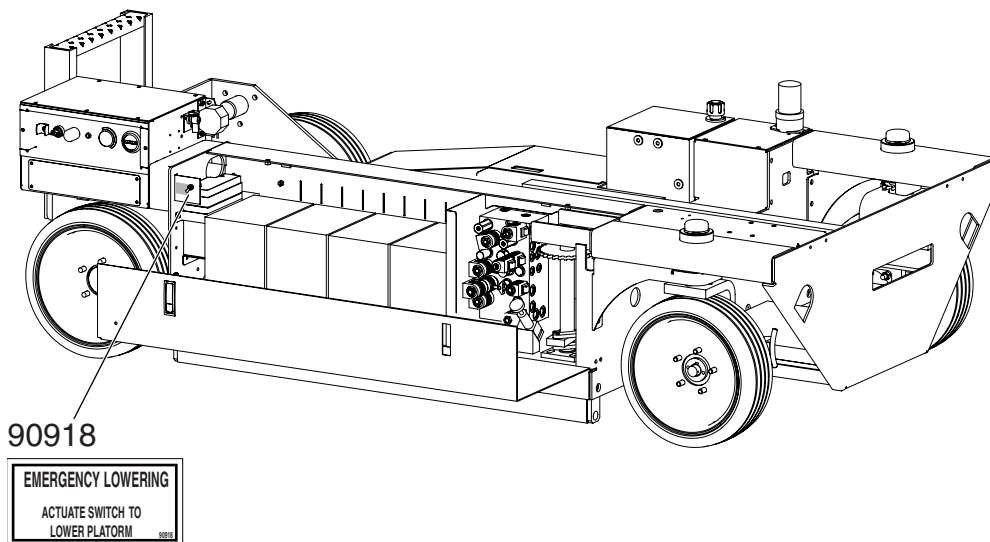



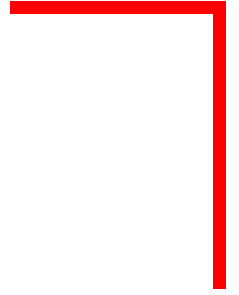

**SECTION 3:  
MAINTENANCE**

# GENERAL MAINTENANCE TIPS

Regular inspection and conscientious maintenance is the key to efficient economical operation of your scissor lift. It will help to assure that your equipment will perform satisfactorily with a minimum of service and repair.

The actual operating environment of the machine governs the inspection schedule. Correct lubrication is an essential part of the preventative maintenance to minimize wear on working parts and ensure against premature failure. By maintaining correct lubrication, the possibility of mechanical failure and resulting downtime is reduced to a minimum.



**NEVER PERFORM SERVICE ON THE MACHINE (WITH THE PLATFORM ELEVATED) WITHOUT FIRST BLOCKING THE BEAMS (SCISSORS) ASSEMBLY IN PLACE USING THE MAINTENANCE LOCK!**

- ◆ Block scissors assembly using maintenance lock if machine is in the elevated/extended position.
- ◆ Never leave hydraulic components or hoses open. They must be protected from contamination (including rain) at all times.
- ◆ Never open a hydraulic system when there are contaminants in the air.
- ◆ Always clean the surrounding area before opening hydraulic systems.
- ◆ Use only recommended lubricants. Improper lubricants or incompatible lubricants may be as harmful as no lubrication.
- ◆ Watch for makeshift “fixes” which can jeopardize safety as well as lead to more costly repair.

## GENERAL MAINTENANCE TIPS (CONTINUED).....



**HYDRAULIC FLUID UNDER PRESSURE CAN PENETRATE AND BURN SKIN, DAMAGE EYES, AND MAY CAUSE SERIOUS INJURY, BLINDNESS, AND EVEN DEATH. CORRECT LEAKS IMMEDIATELY.**



**Failure to perform preventive maintenance at recommended intervals may result in the unit being operated with a defect that could result in injury or death of the operator.**

**Immediately report to your supervisor any Defect or malfunction. Any defect shall be repaired prior to continued use of the scissor lift.**

**Inspection and maintenance should be performed by qualified personnel familiar with the equipment.**

**Fluid leaks under pressure may not always be visible. Check for pin hole leaks with a piece of cardboard, not your hand.**

# PRESTART INSPECTION



**THIS INSPECTION MUST BE COMPLETED BEFORE MACHINE USE EACH DAY OR AT THE BEGINNING OF EACH SHIFT. FAILURE TO DO SO COULD RESULT IN DEATH OR SERIOUS INJURY.**

- ◆ User/Operator is responsible for the Pre-Start Inspection.
- ◆ Keep inspection records up-to-date.
- ◆ Record and report all discrepancies to your supervisor.

**MODEL NUMBER** \_\_\_\_\_ **SERIAL NUMBER** \_\_\_\_\_

## INITIAL

## DESCRIPTION

- |       |   |
|-------|---|
| _____ | 1. Perform a visual inspection of all machine components, i.e. missing parts, torn or loose hoses, hydraulic fluid leaks, torn or disconnected wires, damaged tires etc. Replace components as necessary. |
| _____ | 2. Check the hydraulic fluid level with the platform fully lowered.   |
| _____ | 3. Check the tires for damage. Check wheel lug nuts for tightness.  |
| _____ | 4. Check the hoses and the cables for worn areas or chafing. Replace if necessary.  |
| _____ | 5. Check the platform rails and safety gate for damage.   |
| _____ | 6. Check the pivot pins for security.   |
| _____ | 7. Check that all warning and instructional labels are legible and secure.  |
| _____ | 8. Inspect the platform control. Ensure the load capacity is clearly marked.  |
| _____ | 9. Check the hydraulic system pressure (See Machine Specification). If the pressure is low, determine the reason and repair in accordance with accepted procedures as outlined in the service manual.     |



# PRESTART INSPECTION (CONTINUED).....

**INITIAL**      **DESCRIPTION**

\_\_\_\_\_

10. Check the base controls for proper operation. Check all switches and push buttons for proper operation.

\_\_\_\_\_

11. Check the platform controls for proper operation. Check all switches and push buttons, as well as ensuring that the drive controller returns to neutral.

**DATE** \_\_\_\_\_ **INSPECTED BY** \_\_\_\_\_



# FREQUENT INSPECTION



**THIS INSPECTION MUST BE COMPLETED EVERY 3 MONTHS OF SERVICE OR 150 HOURS, WHICHEVER OCCURS FIRST, OR IF A MACHINE HAS BEEN OUT OF SERVICE FOR GREATER THAN 3 MONTHS. FAILURE TO DO SO COULD RESULT IN DEATH OR SERIOUS INJURY.**

- ◆ Owner/User is responsible for Frequent Inspections.
- ◆ The inspection must be performed by a person(s) qualified as a mechanic on this specific make and model of aerial work platform.
- ◆ Keep inspection records up-to-date.
- ◆ Record and report all discrepancies to your supervisor.

**MODEL NUMBER** \_\_\_\_\_ **SERIAL NUMBER** \_\_\_\_\_

**INITIAL**      **DESCRIPTION**

- |       |  |
|-------|--|
| _____ | 1. Perform all checks listed on Prestart Inspection.   |
| _____ | 2. Inspect the condition of hydraulic fluid in the reservoir. Oil should have a clear amber color.           |
| _____ | 3. Inspect the entire machine for signs of damage, broken welds, loose bolts, improper or makeshift repairs. |
| _____ | 4. Check the pin joints and retaining rings for security.  |
| _____ | 5. Check if tires are leaning in or out.   |
| _____ | 6. Check that all adjustable flow valves are locked, check setting if any are not locked.                    |
| _____ | 7. Check that the platform does not drift down with a full load.   |
| _____ | 8. Check the electrical motor brushes.   |

**DATE** \_\_\_\_\_ **INSPECTED BY** \_\_\_\_\_



# ANNUAL INSPECTION



**THIS INSPECTION MUST BE COMPLETED NO LATER THAN 13 MONTHS FROM THE DATE OF THE PRIOR ANNUAL INSPECTION. FAILURE TO ACCOMPLISH THIS INSPECTION COULD RESULT IN DEATH OR SERIOUS INJURY.**

**MODEL NUMBER \_\_\_\_\_ SERIAL NUMBER \_\_\_\_\_**

- ◆ Owner/User is responsible for Annual Inspections.
- ◆ The inspection must be performed by a person(s) qualified as a mechanic on this specific make and model of aerial work platform.
- ◆ Keep inspection records up-to-date.
- ◆ Record and report all discrepancies to your supervisor.

**ANNUAL INSPECTION TO BE PERFORMED IN ACCORDANCE WITH THE ANNUAL INSPECTION REPORT SHOWN ON THE FOLLOWING PAGE**

# Annual Inspection Report



**Aerial Platform Sales Corp.**

1775 Park Street, Suite 77 • Selma, CA 93662 USA  
800-387-4575 • 559-891-2488 • Fax: 559-891-2493

Date	_____
Serial Number	_____
Model Number	_____
Date Of Last Inspection	_____
Date Placed In Service	_____

Customer	_____
Street	_____
City/State/Zip	_____
Phone Number	_____
Contact	_____

Dealer	_____
Street	_____
City/State/Zip	_____
Phone Number	_____
Contact	_____

- Check each item listed below.
- Use proper Operating, Service, and  Maintenance manual for specific information and settings.
- If an item is found to be "Unacceptable" make the necessary  repairs and check the "Repaired" box.
- When all items are "Acceptable", the unit is ready for service.

**Key: "Y" Yes/Acceptable**  
**"N" No/Unacceptable**  
**"R" Repaired**  
**"U" Unnecessary/Not Applicable**

	Y	N	R	U		Y	N	R	U		Y	N	R	U
<b>Decals:</b>					<b>Base:</b>					<b>Operation:</b>				
Proper Placement/Quantity					Cover Panels Secure					Wires Tight				
Legibility					Base Fasteners Tight					Switches Secure				
Correct Capacity Noted					Bolts Tight					All Functions Operational				
<b>Rails:</b>					Front Axle Mounting (4WD)					<b>Emergency Down:</b>				
All Rail Fasteners Secure					Rear Axle Mounting (4WD)					Operational				
Entry Gate/Chain Closes Properly					<b>Front Axle/Front Wheel Assemblies:</b>					<b>Slow Speed Limit Switch:</b>				
Manual/Safety Data In Box					Wheel Motors-Mounting Secure					Set Properly				
Rear Rail Pad In Place					Wheel Motors-Leaks					<b>Pothole Bars:</b>				
<b>Extending Platform:</b>					Lug Nuts Torqued Properly					Operate Smoothly				
Slides Freely					Steering Cylinder Pins Secure					Lock In Place				
Latches In Stowed Position					Pivot Points Lubed					Limit Switches Adjusted				
Latches In Extended Position					<b>Drive Assembly Front Hubs:</b>					<b>Pressures &amp; Hydraulics:</b>				
Rail Latches Work Properly					Castle Nut Torqued Properly					Oil Filter Secure/Chg				
Cable Secure					Cotter Pinned					Oil Level Correct/Chg				
<b>Platform:</b>					<b>Rear Axle/Rear Wheel Assemblies:</b>					Steering Pressure Set				
Platform Bolts Tight					Brakes Operational					Drive Pressure Set				
Platform Structure					Wheel Motors-Mounting Secure					Lift Pressure Set				
<b>Platform Overload System:</b>					Wheel Motors-Leaks					<b>Engine:</b>				
Functional					Lug Nuts Torqued Properly					Engine Mounts Tight				
Calibrated					Axle Pivot Libed (4WD)					Fuel Lines Secure				
<b>Wire Harnesses:</b>					Axle Lock Operational					Fuel Lines Free Of Leaks				
Mounted Correctly					<b>Component Area:</b>					Fuer Tanks Secure				
Physical Appearance					Valve Manifold(s) Secure					Fuel Shut Off Valves Func.				
110/220V Outlet Safe/Working					Hoses Tight/No Leaks					All Shields/Guards In Place				
<b>Scissors:</b>					D/C Mtr(s) Secure/Operational					Oil Level				
Beam Structures					Contactors Secure					Oil Filter				
Welds					Pump Secure					Air Filter				
Retaining Rings					<b>Batteries:</b>					<b>Options Operational:</b>				
Upper Cylinder Pins Secure					Secure					Hour Meter				
Lower Cylinder Pins Secure					Fully Charged					Battery Indicator				
Lower Beam Mounts tight					<b>Battery Charger:</b>					Warning Light				
Rollers Turn Freely					Secure					Warning Horn				
<b>Maintenance Locks:</b>					Operational					Generator				
Secure					<b>Emergency Stop:</b>					Converter				
Operational					Breaks All Circuits									

Comments: \_\_\_\_\_

Signature/Mechanic: \_\_\_\_\_ Date: \_\_\_\_\_  
 Signature/Owner-User: \_\_\_\_\_ Date: \_\_\_\_\_

P/N 90728 Rev. 1





# TROUBLESHOOTING



**SHOULD YOU EXPERIENCE ERRATIC OPERATION OR NOTICE ANY MALFUNCTION WHILE OPERATING THIS MACHINE, DISCONTINUE USE IMMEDIATELY.**

**CALL FOR ASSISTANCE AND REPORT THE INCIDENT TO YOUR SUPERVISOR, AND DO NOT USE THE MACHINE UNTIL IT HAS BEEN CHECKED BY A TRAINED, QUALIFIED MECHANIC.**

## **WHAT TO CHECK IF FUNCTIONS WILL NOT OPERATE**

- ◆ Battery cutoff switch?
- ◆ Is a function toggle switch or the enable switch not activated?
- ◆ Is the Base/Off/Platform switch in the proper position?
- ◆ Batteries fully charged?
- ◆ Check emergency stop buttons at both base and platform?
- ◆ Hydraulic fluid level low?
- ◆ Obvious fluid leak or damaged component?
- ◆ Are any wires pulled out or loose?

# LUBRICATION DIAGRAM

## Hydraulic Lubrication

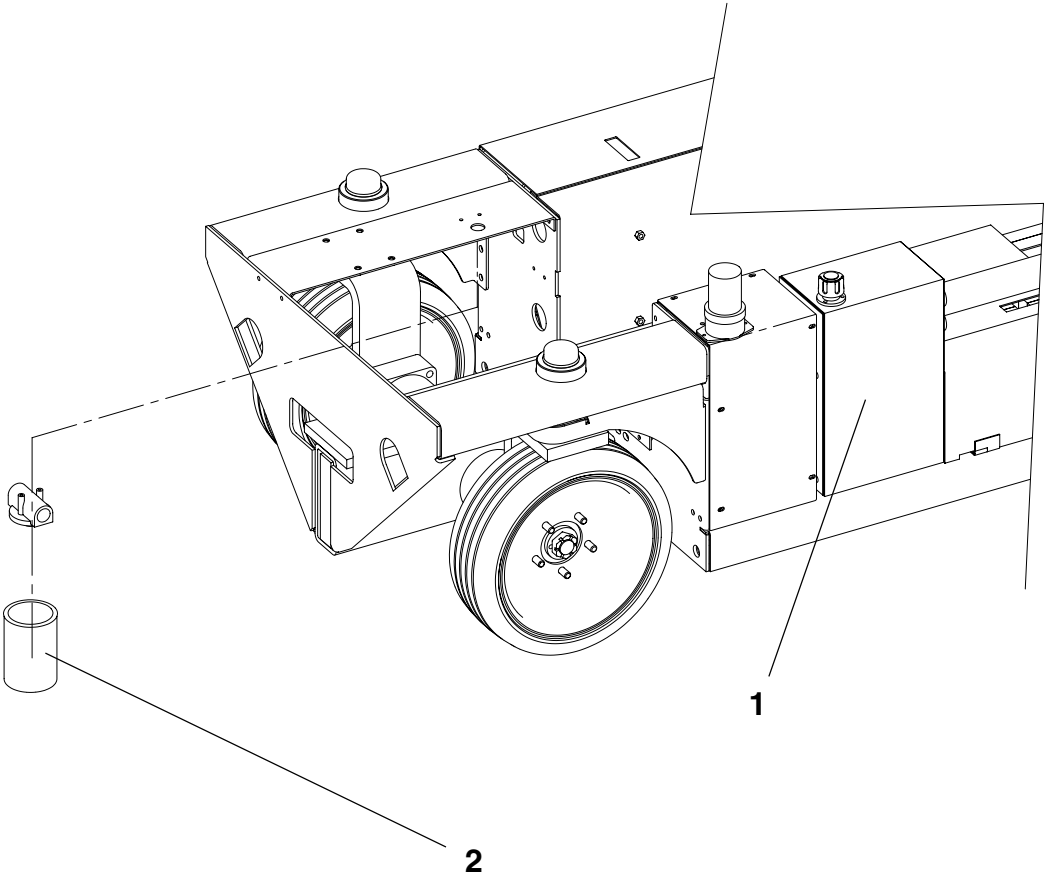

# LUBRICATION CHART

NO.	ITEM	SPECIFICATION	FREQUENCY OF LUBRICATION
1	Hydraulic Reservoir	Anti-Wear 150 SSU (ISO 32/mil spec 0-5606) Fill To The Top Of The Sight Gauge With Platform In The Stowed Position.	Check Daily. Analyze Every Six (6) Months Or 500 Hours. Change Yearly Or Every 1,000 Hours, Whichever Occurs First.
2	Hydraulic Filter	Filter Element	Change Every Six Months Or 500 Hours, Whichever Occurs First For Normal Usage. Change Every Three Months Or 300 Hours, Whichever Occurs First For Severe Usage.







## Limited Owner Warranty

MEC Aerial Platform Sales Corp. warrants its equipment to the original purchaser against defects in material and/or workmanship under normal use and service for one (1) year from date of registered sale or date the unit left the factory if not registered. MEC Aerial Platform Sales Corp. further warrants the structural weldments of the main frame and scissor arms to be free from defects in material or workmanship for five (5) years from date of registered sale or date unit left the factory if not registered. Excluded from such warranty is the battery(s) which carries a ninety (90) day warranty from described purchase date. Warranty claims within such warranty period shall be limited to repair or replacement, MEC Aerial Platform Sales Corp's option, of the defective part in question and labor to perform the necessary repair or replacement based on MEC Aerial Platform Sales Corp's then current flat rate, provided the defective part in question is shipped prepaid to MEC Aerial Platform Sales Corp. and is found upon inspection by MEC Aerial Platform Sales Corp. to be defective in material and/or workmanship. MEC Aerial Platform Sales Corp. shall not be liable for any consequential, incidental or contingent damages whatsoever. Use of other than factory authorized parts; misuse, improper maintenance, or modification of the equipment voids this warranty. The foregoing warranty is exclusive and in lieu of all other warranties, express or implied. All such other warranties, including implied warranties of merchantability and of fitness for a particular purpose, are hereby excluded. No Dealer, Sales Representative, or other person purporting to act on behalf of MEC Aerial Platform Sales Corp. is authorized to alter the terms of this warranty, or in any manner assume on behalf of MEC Aerial Platform Sales Corp. any liability or obligation which exceeds MEC Aerial Platform Sales Corp's obligations under this warranty.



**Aerial Platforms Sales Corp.**

1775 Park Street, Suite 77 • Selma, CA 93662 USA  
Ph: 1-866-379-7278 • 559-263-9626 • Fax: 559-263-9631  
[www.mecawp.com](http://www.mecawp.com)