

PANORAMIC 6072 - UK



The supremacy of ideas.

PANORAMIC

P 72.10

P 60.10



CHARACTERISTICS AND PERFORMANCE



Cab

- Complies with ISO 3449 (FOPS) and ISO 3471 (ROPS) standards.
- “4 x 1” electro-proportional joystick.

Boom

- Telescopic, with sections sliding on adjustable low-friction pads.
- Hydraulic extension mechanism, hydraulic pipes and electrics are totally enclosed within the boom assembly to ensure maximum protection and reliability.
- Integral boom side-shift mechanism.

Quick-attach carriage

- The Tac-Lock quick attachment fitting system is hydraulically controlled from the cab.
- Standard double-acting hydraulic service, with quick couplings, for the operation of hydraulically powered attachments.

Frame levelling

- Hydraulically operated from the cab. Frame levelling $\pm 10\%$.

Forks

- Floating type. Length 1200mm. Section 150 x 60mm.
- Fork spacing is manually adjustable between 450 and 1010mm.

Steering

- Four drive/steer wheels, with automatic wheel synchronisation in the event of any misalignment and selection of three steering modes from the cab.

Engine

- Direct injection, water cooled, 4 cylinder Perkins Euro 2 turbo diesel engine producing 74.5kW-101HP at 2400rpm (97/68/CE).

Transmission

- Hydrostatic with electronically controlled variable displacement pump.
- Continuous and automatic speed variation, from zero to maximum speed, solely with the accelerator pedal.
- Two-speed mechanical range gearbox.
- Inching-Control pedal to proportionately reduce travel speed whilst maintaining high engine speed for hydraulic operation e.g. during loading operations.
- Finger-Touch system makes it possible to change between forward and reverse

direction with the driver keeping both hands firmly on the steering wheel.

- Permanent four-wheel drive.
- Portal axles ensuring excellent ground clearance.

Braking system

- Disc service brakes on all 4 wheels, hydraulically operated and acting on the differential output shafts.
- Disc parking brake with automatic locking feature and hydraulic release control, acting on the main transmission shaft.

Hydraulic system

- Variable delivery Load-Sensing pump.
- Maximum operating capacity: 108lpm.
- Working pressure: 210bar.

Electrics

- 12V system with 100Ah battery and 90A alternator.
- Full road lighting and rotating beacon.
- Manual battery isolator switch (optional automatic switch).

Service capacities

- Hydraulic oil: 95 litres
- Diesel fuel: 155 litres
- Hydrostatic oil: 12 litres
- Engine oil: 8.5 litres
- Coolant: 12 litres

Tyres

- 400/70-20 (P 60.10) and 18-19.5 (P 72.10).

Available options

- Rear axle differential lock.
- Automatic battery isolator.
- Manual control air conditioning.
- Windscreen wiper on the roof window.
- Four working lights on the cab (two front lights and two rear).
- Pneumatic seat.
- BSS boom suspension system.
- Roof and front window mounted sun blinds.

Boom side-shift - a Merlo exclusive

The integral chassis side-shift mechanism gently swings the upper part of the chassis, and with it, the telescopic boom across the longitudinal axis of the machine. The load can be precisely placed without repositioning the machine. Using the side-shift mechanism in no way detracts from the performance or stability of the Panoramic as it is an integral part of the design, not a mere attachment, and produces the following maximum sideways displacement.

| PANORAMIC | | P 72.10 | P 60.10 |
|------------|----|-----------|-----------|
| Side-shift | mm | ± 250 | ± 250 |

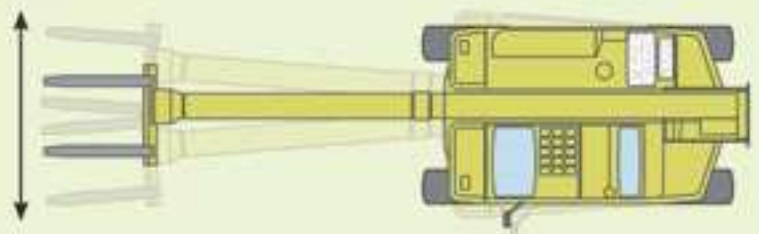

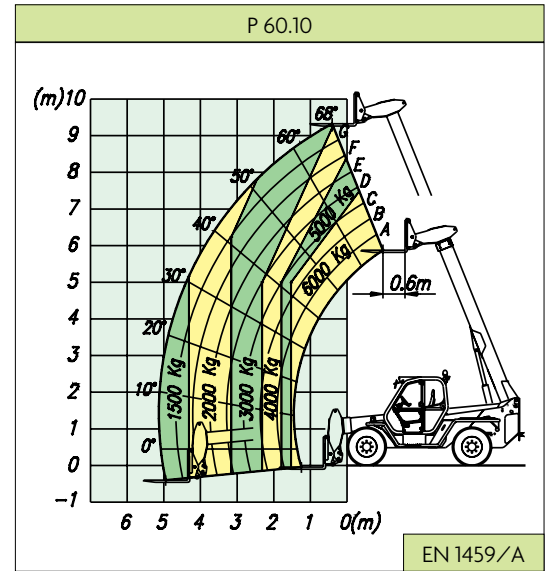
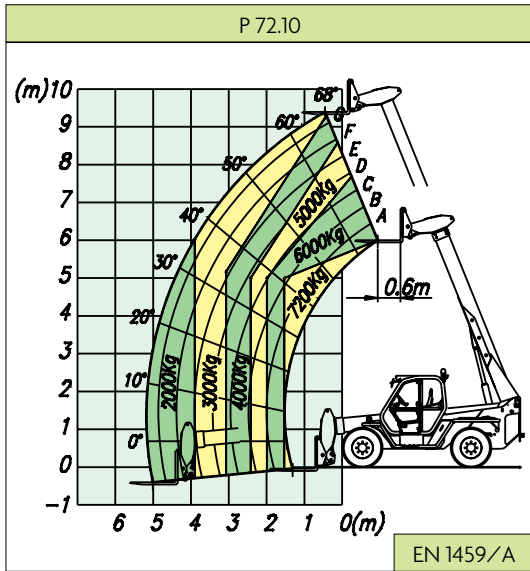

| PANORAMIC | | P 72.10 | P 60.10 |
|--|-------|----------|---------|
| Weight | | | |
| Total empty weight (with forks) | kg | 10500 | 9890 |
| Performance | | | |
| Rated maximum load | kg | 7200 | 6000 |
| Maximum lift height | m | 9.55 | 9.55 |
| Maximum forward reach | m | 5.5 | 5.5 |
| Lift height at full capacity | m | 6 | 7.8 |
| Reach at full capacity | m | 1.6 | 1.6 |
| Capacity at full lift height | kg | 4000 | 4000 |
| Capacity at full forward reach | kg | 2000 | 1500 |
| Low emission (Euro 2) engine | | turbo | |
| Power at 2400rpm (97/68/CE) | kW/HP | 74.5/101 | |
| Speed ratios | | | |
| 1 st gear | kph | 16 | 16 |
| 2 nd gear (self-limiting maximum speed) | kph | 40 | 40 |

| PANORAMIC | | P 72.10 | P 60.10 |
|-------------------|----|--------------------|--------------------|
| Dimensions | | | |
| A | mm | 5345 | 5345 |
| B | mm | 1235 | 1235 |
| C | mm | 2875 | 2875 |
| D | mm | 1300 | 1300 |
| E | mm | 4645 | 4645 |
| F | mm | 480 | 480 |
| H | mm | 2240 | 2240 |
| M | mm | 995 ⁽¹⁾ | 995 ⁽¹⁾ |
| P | mm | 2440 | 2440 |
| R | mm | 3950 | 3950 |
| S | mm | 4970 | 4970 |
| Z | mm | 850 | 850 |

⁽¹⁾ Useful internal width

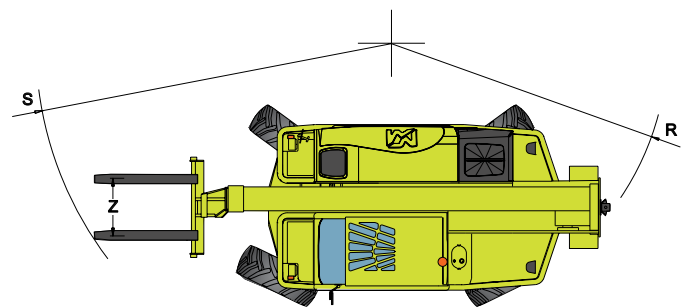
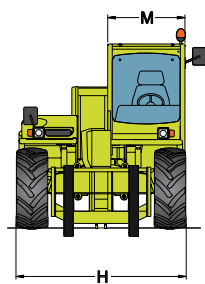
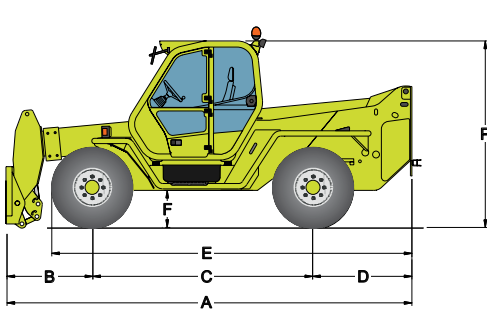

The side mounted engine ensures excellent accessibility for maintenance. Technicians can work in total safety with their feet firmly on the ground.



A comprehensive instrument panel can be read in all lighting conditions.



The optional air suspended seat ensures excellent comfort.





Help is always nearby

Day after day, choosing a Merlo product brings the advantages of the most advanced technology and the practicality of safe and comfortable equipment, of which the very best can be expected.

Merlo Service ensures a close and continuing bond with the customer, provided by a worldwide network of more than 500 Service Centres guaranteeing experienced and trained technical assistance close at hand.

Building professionalism

Evidently, carelessness and a lack of respect for the basic principles of safety are often the causes of accidents with lifting equipment, often through the lack of an adequate training scheme. The close link between training and safety is a part of everyone's experience and must be continually updated as part of our professional development, a role for which the new Merlo Research and Training Centre is admirably suited.



MERLO S.P.A.

Via Nazionale 9
12020 S. Defendente di Cervasca - Cuneo - Italia
Tel. +39 0171 614111 - Fax +39 0171 614100
www.merlo.com info@merlo.com

MERLO UK LTD

The Paddocks, Headlands Business Park
Salisbury Road - Ringwood - Hants BH24 3PB
Tel. 01425-480806 - Fax 01425-477478
www.merlo.co.uk info@merlo.co.uk

COMPANY
WITH QUALITY MANAGEMENT
SYSTEM CERTIFIED BY DNV
ISO 9001:2000

Courtesy of Crane.Market

MERLO has a policy of continual product research and development and specifications are subject to change without notice. Models illustrated may include attachments and options that are not standard.

MARKETING MERLO R. 340 UK 0506 - Progetto grafico olimbatrazzi - Stampa Agam, Cuneo