

National Crane Series 1400A

Product Guide

ASME B30.5
Imperial 85%



Features

- 29,9 t (33 USt) rating
- 38,72 m (127 ft) five-section boom
- Self-lubricating "Easy Glide" wear pads
- Internal anti-two-block
- Vision™ cab



Features

National Crane Series 1400A

- 29,9 t (33 USt) maximum capacity
- 41,15 m (135 ft) maximum tip height (main boom)
- 52,43 m (172 ft) maximum tip height (boom with jib)



Deluxe operator's cab

Vision Cab™ has a rigid powder coated steel structure, is well insulated, with ample safety glass for operator visibility and comfort.

Multi-position seat with arm rest single axis controls, ventilation fans, diesel heater, and wipers. Optional air conditioning is available. Optional open-seat control station in lieu of enclosed cab is available.



Outriggers

Two sets of “H” style outriggers with 7,47 m (24 ft 6 in) span, with removable ball and socket aluminum foot pads. Independent controls located on each side of the crane can be positioned at mid-span setting of 5,18 m (17 ft). Single front stabilizer (SFO) comes with first-up feature.

Overload protection

All National Crane boom trucks are equipped with overload protection. A Load Moment Indicator (LMI) is standard on all Series 1400A machines. The LMI display console with Work Area Definition System (WADS) is weatherproof. The LCD display is visible in full or low light and displays all crane load lifting values simultaneously.



Five-section boom

At 38,72 m (127 ft), the Series 1400A five-section boom is the longest in its size range. The long boom allows the operator to perform more lifts without the use of a jib, reducing setup time and improving efficiency. Also available are optional four-section boom lengths of 30,5 m (100 ft) and 33,5 m (110 ft).

Best in class performance and serviceability

- The stronger standard torsion box improves rigidity, reduces truck frame flex and reduces the need for counterweight.
- Easy Glide Boom Wear Pads reduce the conditions that cause boom chatter and vibration. The net result is smoother crane operation.
- Speedy-reeve boom tip and sheave blocks simplify rigging changes by decreasing the time needed to change line reeving.
- Crane components painted before assembly reduce the chance of rust, improve serviceability and enhance the appearance of the crane.
- Internal anti-two block wiring standard on the 1400A routes the wiring through the inside of the boom eliminating the possibility of snagging the wire on obstructions.
- Bearings on the boom and retract cables can be greased through access holes in the boom side plates and number of internal boom parts has been reduced improving serviceability.
- The Series 1400A is supplied with continuous rotation standard, along with the “glide swing” feature, allowing free swing during rotation, and a manually applied foot brake.
- Adjustable swing speed comes standard on the 1400A. A control knob located on the swing motor brake release valve can be easily adjusted to the crane operator’s swing speed preference.
- Oil cooler mounted at boom rest with electric fan is standard.
- Pressure compensated hydraulic system control valves come with load-sensing variable displacement piston pump.



*Product may be shown with optional equipment.

Contents

Mounting configurations	5
Specifications	6
Capacities	8
Dimensions specifications	11
Accessories	12

Mounting configuration

The mounting configuration shown is based on the Series 1400A with an 85% stability factor. The complete unit must be installed in accordance with factory requirements and a test performed to determine actual stability and counterweight requirements since individual truck chassis vary. If bare truck weights are not met, counterweight will be required. The front bumper stabilizer (SFO) is required for all installations. Chassis must be equipped with a front frame extension suitable for SFO addition. Contact factory for complete chassis specifications.

Working area	360°
Gross Axle Weight Rating Front.....	9072 kg (20,000 lb)*
Gross Axle Weight Rating Rear.....	15 422 kg (34,000 lb)*
Gross Vehicle Weight Rating.....	24 494 kg (54,000 lb)*
Wheelbase.....	Minimum 655 cm (258 in)
Cab to Axle/trunnion (CA/CT).....	Minimum 457 cm (180 in)
After Frame (AF).....	234 cm (92 in) minimum
Frame Section Modulus (SM), front axle to end of afterframe, with 758 MPa (110,000 PSI).....	492 cm ³ (30 in ³)
Stability Weight, Front	4082 kg (9000 lb) minimum**
Stability Weight, Rear.....	3629 kg (8000 lb) minimum**
Estimated Average Final Weight.....	23 585 kg (51,880 lb)***

The diagram shows the 360° working area that can be achieved with the front stabilizer (standard on the Series 1400A). The front stabilizer is required when extending the boom and lifting loads forward of the outriggers. A minimum of 164 cm³ (10-in³) section modulus at 759 MPa (110,000 psi) is required from the rear of the front spring hanger forward to the front stabilizer. Integral front frame extension required.

* Required to mount basic crane with 9,15 m (30 ft) jib option. Additional options or heavier bare chassis weights will require additional axles or a GVWR in excess of 24 494 kg (54,000 lb); in some states, special permits for overload are required.

** Estimated axle scale weights prior to installation of crane, stabilizers and subbase for 85% stability.

*** Includes basic crane without jib, 379 L (100 gal) fuel tank and two workers, 136 kg (300 lb) in cab.

Note: Chassis will require integral extended front frame rails for SFO addition.

Truck requirements

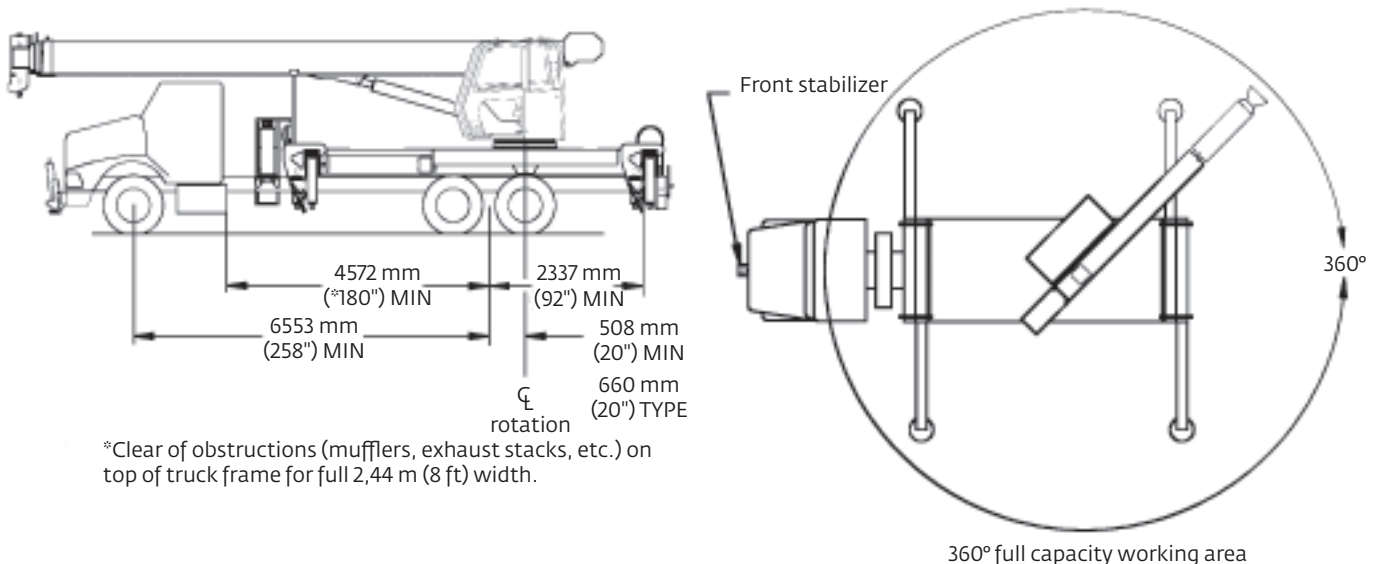

Notes:

- Gross Vehicle Weight Rating (GVWR) is dependent on all components of the vehicle (axles, tires, springs, frame, etc.) meeting manufacturers' recommendations; always specify GVWR when purchasing trucks.
- Diesel engines require a variable speed governor for smooth crane operation. Electronic fuel-injected engines are required.

- All mounting data is based on a National Crane Series 1400A with the standard subbase and an 85% stability factor.
- The complete unit must be installed in accordance with factory requirements, and a test performed to determine actual stability and counterweight requirements per SAE J765; contact the factory for details.
- Transmission neutral safety interlock switch is required.

Specifications

Boom and jib combinations data

Available in three basic models.

Model 14100A — Equipped with a 9,40 m - 30,49 m (30 ft 10 in - 100 ft) four-section boom. This model can be equipped with a 9,15 m (30 ft) single-section jib or a 9,15 m - 16,46 m (30 ft - 54 ft) two-section jib. Maximum tip height with 9,15 m (30 ft) jib is 41,77 m (137 ft), while maximum tip height with 9,15 m - 16,46 m (30 ft - 54 ft) jib is 49,08 m (161 ft).

9,40 m - 30,49 m (30 ft 10 in - 100 ft) four-section boom

14FJ30M 9,15 m (30 ft) single-section jib



9,40 m - 30,49 m (30 ft 10 in - 100 ft) four-section boom

14FJ54M 9,15 m - 16,46 m (30 ft - 54 ft) two-section jib



Model 14110A — Equipped with a 10,16 m - 33,53 m (33 ft 4 in - 110 ft) four-section boom. This model can be equipped with a 9,15 m (30 ft) single section jib or a 9,15 m - 16,46 m (30 ft - 54 ft) two-section jib. Maximum tip height with 9,15 m (30 ft) jib is 44,82 m (147 ft), while maximum tip height with 16,46 m (54 ft) jib is 52,13 m (171 ft).

10,16 m - 33,53 m (33 ft 4 in - 110 ft) four-section boom

14FJ30M 9,15 m (30 ft) single-section jib



10,16 m - 33,53 m (33 ft 4 in - 110 ft) four-section boom

14FJ54M 9,15 m - 16,46 m (30 ft - 54 ft) two-section jib



Model 14127A — Equipped with a 9,63 m - 38,72 m (31 ft 7 in - 127 ft) five-section boom. This model can be equipped with a 9,15 m (30 ft) single-section jib. Maximum tip height with 9,15 m (30 ft) jib is 50,00 m (164 ft).

9,63 m - 38,72 m (31 ft 7 in - 127 ft) five-section boom

14FJ30M 9,15 m (30 ft) single-section jib



Note: Maximum tip is measured with outriggers/stabilizers fully extended.

Specifications

1400A winch data

- Do not deadhead line block against boom tip when extending boom
- Keep at least 3 wraps of loadline on drum at all times.
- Use only 5/8 in diameter rotation-resistant cable with 45,400 lb breaking strength on this machine.
- MAXIMUM BOOM LENGTH AT MAXIMUM ELEVATION WITH RIGGING SHOWN WITH LOAD BLOCK AT GROUND LEVEL

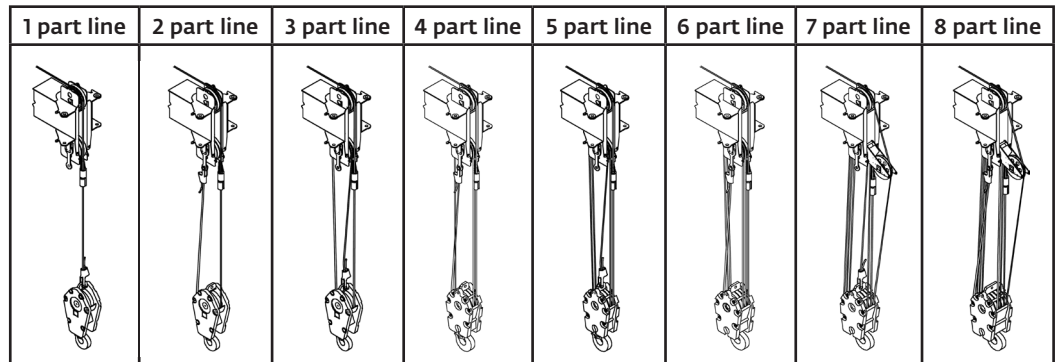

Winch	Cable supplied	Average breaking strength	Lift and speed	Lift and speed	Lift and speed	Lift and speed	Lift and speed	Lift and speed	Lift and speed	Lift and speed
Low speed	5/8" diameter rotation resistant	20 593 kg (45,400 lb)	4082 kg (9000 lb) 52 m/min (170 fpm)	8165 kg (18,000 lb) 26 m/min (85 fpm)	12 247 kg (27,000 lb) 17 m/min (57 fpm)	16 329 kg (36,000 lb) 13 m/min (43 fpm)	20 412 kg (45,000 lb) 10 m/min (34 fpm)	24 494 kg (54,000 lb) 9 m/min (28 fpm)	28 576 kg (63,000 lb) 7 m/min (24 fpm)	29 937 kg (66,000 lb) 6 m/min (21 fpm)
High speed	5/8" diameter rotation resistant	20 593 kg (45,400 lb)	1996 kg (4400 lb) 104 m/min (340 fpm)	3992 kg (8800 lb) 52 m/min (170 fpm)	5987 kg (13,200 lb) 34 m/min (113 fpm)	7983 kg (17,600 lb) 26 m/min (85 fpm)	9979 kg (22,000 lb) 21 m/min (68 fpm)	11 975 kg (26,400 lb) 17 m/min (57 fpm)	13 971 kg (30,800 lb) 15 m/min (49 fpm)	15 967 kg (35,200 lb) 13 m/min (43 fpm)

Winch	Full drum pull	Allowable cable pull
Standard planetary	1996 kg (4400 lb) high speed 4082 kg (9000 lb) low speed	4119 kg (9080 lb)

Loadline deduct		
Block type	Rating	Weight
Aux boom head		45 kg (100 lb)
Downhaul weight	4,53 t (5 USt)	82 kg (180 lb)
1-sheave block	13,60 t (15 USt)	170 kg (375 lb)
2-sheave block	22,67 t (25 USt)	290 kg (640 lb)
3-sheave block	31,74 t (35 USt)	395 kg (870 lb)
4-sheave block	32,65 t (36 USt)	440 kg (970 lb)

THIS CHART IS ONLY A GUIDE AND SHOULD NOT BE USED TO OPERATE THE CRANE.

The individual crane's load chart, operating instructions and other instructional plates must be read and understood prior to operating the crane.

Capacities

100 ft boom with 30 ft jib, full-span outrigger

Other Series 1400A Load Rating Charts are available. National Crane will send you a chart on request – or you may secure needed load rating information through your nearest National Crane dealer.

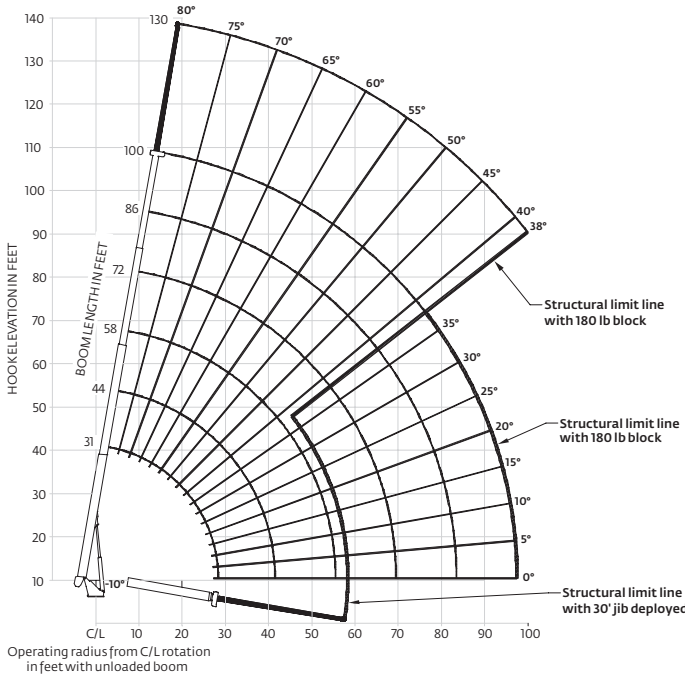

CAUTION:

- Do not operate crane booms, jib extensions, any accessories or loads within 3 m (10 ft) of live power lines or other conductors of electricity.
- Jib and boom capacities shown are maximum for each section.
- Do not exceed capacities at reduced radii.
- Load ratings shown on the appropriate charts are maximum allowable loads with the crane mounted on a factory-approved truck and all outriggers at either full span or at mid span range and set on a firm level surface so that the crane is level and all tires are suspended.
- Always level the crane with the level indicator located on the crane.
- The operator must reduce load to allow for factors such as wind, ground conditions, operating speeds and their effects on freely suspended loads.
- Overloading this crane may cause structural collapse or instability.
- Weights on any accessories attached to the boom or loadline must be deducted from the load chart capacities.
- Do not exceed jib capabilities at any reduced boom lengths.
- Do not deadhead lineblock against boom tip when extending boom or winching up.
- Keep at least three wraps of loadline on drum at all times.
- Use only specified cable with this machine.

NOTE:

1. Operate with jib by radius when main boom is fully extended. If necessary increase boom angle to maintain loaded radius.
2. Operate with jib by boom angle when main boom is not fully extended. Do not exceed rated jib capacities at any reduced boom lengths.

Load chart

31 ft - 100 ft BOOM RATED LOADS WITHOUT JIB

LOADED RADIUS (ft)	LOADED BOOM ANGLE	31 ft BOOM (lb)	LOADED BOOM ANGLE	A 44 ft BOOM (lb)	LOADED BOOM ANGLE	B 58 ft BOOM (lb)	LOADED BOOM ANGLE	C 72 ft BOOM (lb)	LOADED BOOM ANGLE	D 86 ft BOOM (lb)	LOADED BOOM ANGLE	100 ft BOOM (lb)
6	75.5	66,000										
8	71.2	52,500										
10	66.9	43,000	75	38,500								
12	62.5	39,400	72.3	34,000	77.5	28,000						
15	55.4	33,000	68	28,600	74.4	25,600	78	23,000				
20	42	24,350	60.3	22,000	69	19,700	73.8	18,400	77	17,100	78.9	11,800
25	23.3	17,500	52.5	18,000	63.4	16,500	69.7	15,000	73.4	14,000	76.1	11,200
30			43.5	15,300	57.6	14,000	65.1	12,700	69.7	11,750	73.3	10,800
35			32.6	12,800	51	12,500	60.3	10,900	66.2	10,200	70.2	9400
40			15	10,000	44.3	10,750	55.5	9650	62.8	9200	67.2	8300
45					37	8800	50.8	8100	58.8	7600	64.2	7300
50					27.1	7000	45.2	7200	50.3	6500	60.8	6300
55					10.1	5600	39	6000	54.4	5900	57.3	5200
60							31.4	4800	45.5	5000	53.6	4500
65							22.2	4000	40.2	4000	49.9	4000
70									34.3	3400	45.9	3300
75									27.6	2700	41.5	2800
80									18.1	2200	36.7	2300
85											31.1	1700
90											24.4	1300
95											15	1000
	0	12,200	0	8000	0	4800	0	2200	0	1200	0	500

30 ft JIB RATED LOADS

LOADED RADIUS (ft)	LOADED BOOM ANGLE	30 ft JIB (lb)
30	78	5500
35	76	5450
40	74	5400
45	72	5100
50	69.6	4600
55	67.4	4250
60	65	3950
65	62.5	3600
70	60	3400
75	57.4	3100
80	54.6	2600
85	51.7	2150
90	48.8	1700
95	45.5	1300
100	42	1000
105	38.2	700

*Shaded areas are structurally limited capacities.

THIS CHART IS ONLY A GUIDE AND SHOULD NOT BE USED TO OPERATE THE CRANE.

The individual crane's load chart, operating instructions and other instructional plates must be read and understood prior to operating the crane.

Courtesy of Crane.Market

Capacities

110 ft boom with 30 ft - 54 ft jib, full-span outrigger

Other Series 1400A Load Rating Charts are available. National Crane will send you a chart on request – or you may secure needed load rating information through your nearest National Crane dealer.

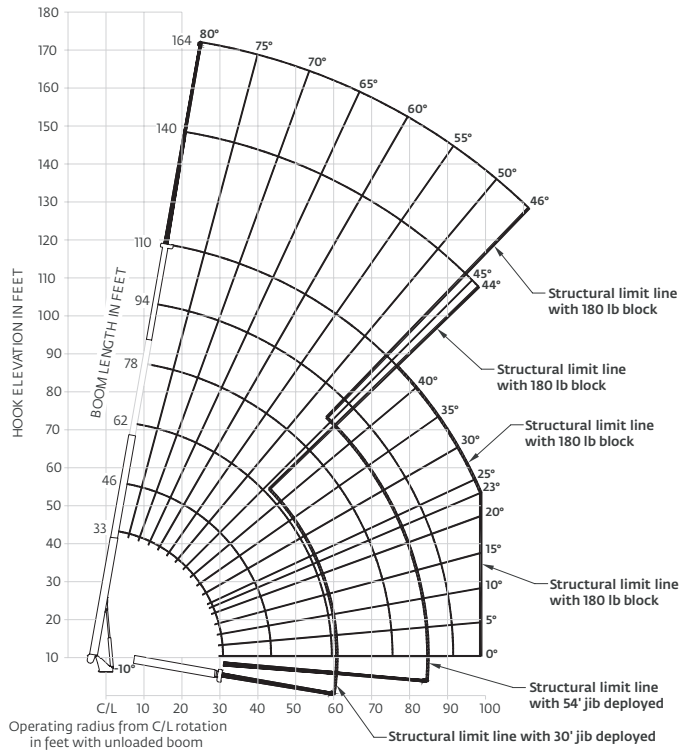

CAUTION:

- Do not operate crane booms, jib extensions, any accessories or loads within 3 m (10 ft) of live power lines or other conductors of electricity.
- Jib and boom capacities shown are maximum for each section.
- Do not exceed capacities at reduced radii.
- Load ratings shown on the appropriate charts are maximum allowable loads with the crane mounted on a factory-approved truck and all outriggers at either full span or at mid span range and set on a firm level surface so that the crane is level and all tires are suspended.
- Always level the crane with the level indicator located on the crane.
- The operator must reduce load to allow for factors such as wind, ground conditions, operating speeds and their effects on freely suspended loads.
- Overloading this crane may cause structural collapse or instability.
- Weights on any accessories attached to the boom or loadline must be deducted from the load chart capacities.
- Do not exceed jib capabilities at any reduced boom lengths.
- Do not deadhead lineblock against boom tip when extending boom or winching up.
- Keep at least three wraps of loadline on drum at all times.
- Use only specified cable with this machine.

NOTE:

1. Operate with jib by radius when main boom is fully extended. If necessary increase boom angle to maintain loaded radius.
2. Operate with jib by boom angle when main boom is not fully extended. Do not exceed rated jib capacities at any reduced boom lengths.

Load chart

33 ft - 110 ft BOOM RATED LOADS WITHOUT JIB

LOAD RADIUS (ft)	LOADED BOOM ANGLE	33 ft BOOM (lb)	LOADED BOOM ANGLE	A 46 ft BOOM (lb)	LOADED BOOM ANGLE	B 62 ft BOOM (lb)	LOADED BOOM ANGLE	C 78 ft BOOM (lb)	LOADED BOOM ANGLE	D 94 ft BOOM (lb)	LOADED BOOM ANGLE	110 ft BOOM (lb)
6	76.7	66,000										
8	72.8	51,700										
10	68.9	42,200	76	37,000								
12	64.9	38,400	73.4	33,400	78.2	26,900						
15	58.6	32,200	69.3	28,000	75.6	24,900	79.4	22,800				
20	48.5	23,900	62.2	21,650	70.2	19,300	74.8	17,900	78.2	14,100		
25	33.3	17,600	54.4	17,800	64.9	16,050	71	14,550	75.1	12,400	77.4	9200
30			46.2	15,100	59.8	13,600	67	12,300	71.9	11,200	75.1	8700
35			36.3	12,750	54	12,050	63	10,600	68.5	9750	72.5	8000
40			22.9	10,100	47.8	10,450	58.7	9300	65.5	8550	69.6	7200
45					41.6	8750	54.5	7800	61.9	7350	67	6400
50					33.9	7200	49.7	6900	58.2	6250	63.9	5700
55					23.6	5600	44.5	6000	54.4	5500	60.8	4700
60							38.6	4900	50.5	4800	57.6	4000
65							31.9	4000	46.3	4200	54.4	3400
70							23.3	3250	41.7	3450	51	2700
75							8.7	2500	36.6	2750	47.4	2300
80									30.7	2250	43.6	1800
85									23.5	1750	39.3	1200
90									12.5	1250	34.7	1000
95											29.6	800
100											23.3	600
	0	12,000	0	7500	0	4500	0	2100	0	1000		

*Shaded areas are structurally limited capacities.

30 ft - 54 ft JIB RATED LOADS				
LOAD RADIUS (ft)	LOADED BOOM ANGLE	30 ft JIB (lb)	LOADED BOOM ANGLE	54 ft JIB (lb)
30	79.1	5050		
35	77.4	5000	79.5	2650
40	75.6	4950	78.1	2600
45	74.7	4700	77.6	2500
50	71.6	4300	75	2400
55	69.5	4000	73.2	2300
60	67.3	3700	71.4	2200
65	65.1	3400	69.6	2100
70	62.9	3150	67.8	2000
75	60.5	2850	66	1850
80	58	2500	64.1	1750
85	55.5	2000	62.2	1600
90	52.8	1600	60.2	1500
95	50	1200	58	1400
100	47.1	850	55.8	1300
105	43.9	500	53.6	1200
110			51.2	1000
115			48.7	750
120			46.1	500

THIS CHART IS ONLY A GUIDE AND SHOULD NOT BE USED TO OPERATE THE CRANE.

Capacities

127 ft boom with 30 ft jib, full-span outrigger

Other Series 1400A Load Rating Charts are available. National Crane will send you a chart on request – or you may secure needed load rating information through your nearest National Crane dealer.

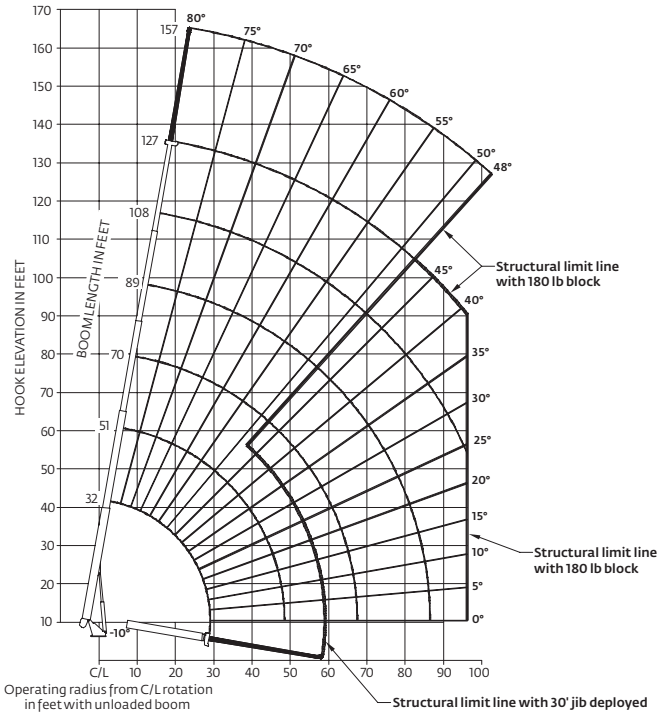

CAUTION:

- Do not operate crane booms, jib extensions, any accessories or loads within 3 m (10 ft) of live power lines or other conductors of electricity.
- Jib and boom capacities shown are maximum for each section.
- Do not exceed capacities at reduced radii.
- Load ratings shown on the appropriate charts are maximum allowable loads with the crane mounted on a factory-approved truck and all outriggers at either full span or at mid span range and set on a firm level surface so that the crane is level and all tires are suspended.
- Always level the crane with the level indicator located on the crane.
- The operator must reduce load to allow for factors such as wind, ground conditions, operating speeds and their effects on freely suspended loads.
- Overloading this crane may cause structural collapse or instability.
- Weights on any accessories attached to the boom or loadline must be deducted from the load chart capacities.
- Do not exceed jib capabilities at any reduced boom lengths.
- Do not deadhead lineblock against boom tip when extending boom or winching up.
- Keep at least three wraps of loadline on drum at all times.
- Use only specified cable with this machine.

NOTE:

1. Operate with jib by radius when main boom is fully extended. If necessary increase boom angle to maintain loaded radius.
2. Operate with jib by boom angle when main boom is not fully extended. Do not exceed rated jib capacities at any reduced boom lengths.

Load chart

32 ft - 127 ft BOOM RATED LOADS WITHOUT JIB

LOAD RADIUS (ft)	LOADED BOOM ANGLE	32 ft BOOM (lb)	LOADED BOOM ANGLE	A 51 ft BOOM (lb)	LOADED BOOM ANGLE	B 70 ft BOOM (lb)	LOADED BOOM ANGLE	C 89 ft BOOM (lb)	LOADED BOOM ANGLE	D 108 ft BOOM (lb)	LOADED BOOM ANGLE	127 ft BOOM (lb)
6	76.5	66,000										
8	72.3	48,050										
10	68.2	41,250	77.6	33,000								
12	64	36,300	75.6	30,050								
15	57.4	30,700	71.7	26,200	77.5	22,800						
20	45.2	24,550	65.5	20,750	73.3	19,200	77.7	16,800				
25	29.2	19,900	59	17,050	68.9	15,600	74.5	14,400	78	12,400		
30			51.9	14,600	64.3	13,100	71	12,050	75.3	10,700	77.9	8000
35			44	12,550	59.5	10,900	67.4	9900	72.7	9200	75.9	7700
40			34.6	10,100	54.5	9400	64.1	8500	69.9	8000	73.7	7300
45			23.4	8050	49.6	8250	60.4	7400	66.9	6900	71.4	6500
50					43.7	7050	56.4	6350	63.8	5650	68.8	5650
55					36.9	5900	52.3	5700	60.7	4950	66.2	4700
60					28.9	4800	48	5100	57.4	4350	63.3	3600
65					17.5	3850	43.1	4200	54.1	3900	60.7	3200
70							37.8	3400	50.6	3450	58	2800
75							31.7	2700	46.8	2850	55.2	2500
80							24.2	2150	42.8	2300	52.3	2200
85							12.8	1600	38.4	1800	49.3	1950
90									33.4	1350	46	1500
95									27.7	950	42.4	1100
100									20.6	600	38.7	750
	0	12,800	0	5400	0	2600	0	1100				

30 ft JIB RATED LOADS

LOAD RADIUS (ft)	LOADED BOOM ANGLE	30 ft JIB (lb)
35	78.6	3850
40	77.1	3700
45	75.4	3550
50	73.8	3400
55	72.1	3250
60	70.3	3100
65	68.5	2950
70	66.5	2700
75	64.5	2550
80	62.4	2300
85	60.2	2100
90	58	1850
95	55.6	1650
100	53.2	1300
105	50.6	950
110	47.8	650

THIS CHART IS ONLY A GUIDE AND SHOULD NOT BE USED TO OPERATE THE CRANE.

The individual crane's load chart, operating instructions and other instructional plates must be read and understood prior to operating the crane.

Courtesy of Crane.Market

Dimensions

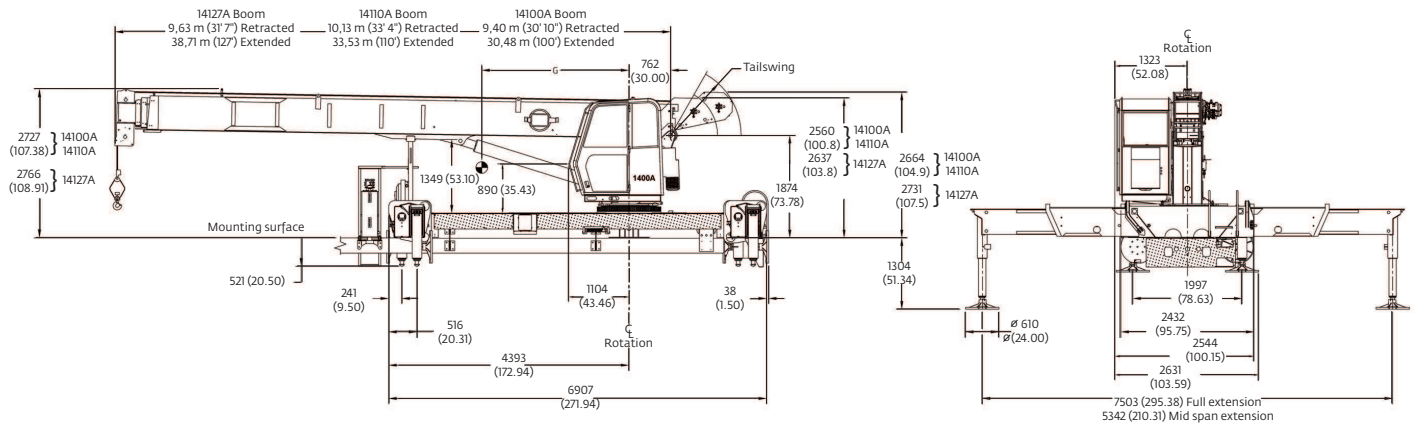

Dimensions are in mm (in) unless otherwise specified.

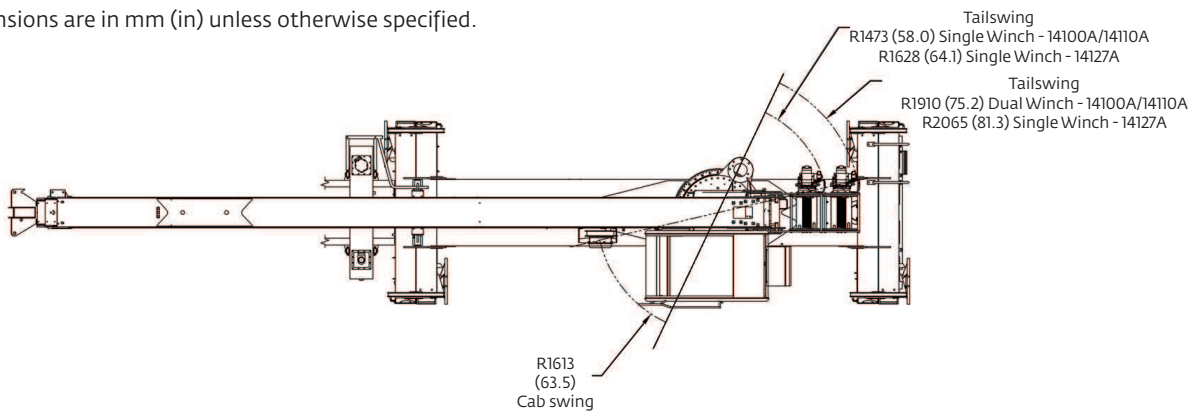

G center of gravity from centerline		
Series	G	w/oil weight ^{2*}
14100A	2032 mm (80 in)	13 473 kg (29,640 lb)
14110A	2083 mm (82 in)	13 868kg (30,510 lb)
14127A	2159 mm (85 ft)	14 718 kg (32,380 lb)

*Weight includes all items including complete HO outriggers, 82 kg (180 lb) downhaul weight, reservoir, decks, ladders and SFO. Booms fully retracted. Pump, and PTO not included.

Accessories

Radio Remote Controls –

Eliminate the handling and maintenance concerns that accompany cabled remotes. Operate to a range of about 76 m (250 ft), varying with conditions.

- **NB4R**

Heavy-duty Personnel Basket –

One and two person baskets for main boom and jib are available.

- **BSA-1**
- **BSA-R1 (provides rotation)**
- **BSAY-2**

Air Conditioning –

Back of cab mounted – self contained modular unit with in-cab cool air outlets. Requires 130+ amp. chassis alternator.

- **AC**

Outrigger Controls at operator's seat in addition to ground controls.

- **ICORC**

Open Seat Controls

- **SSC**

Auxiliary Winch –

9000 lb line pull with 375 ft of 5/8 in diameter rotation-resistant wire rope.

- **WOAW**

Spanish-Language Danger Decals, Control Knobs, and Operators' Manuals

- **SDD**
- **SOM**

Notes

Manitowoc Cranes

Regional headquarters

Americas

Manitowoc, Wisconsin, USA

Tel: +1 920 684 6621

Fax: +1 920 683 6277

Shady Grove, Pennsylvania, USA

Tel: +1 717 597 8121

Fax: +1 717 597 4062

Europe, Middle East, Africa

Dardilly, France

Tel: +33 (0)4 72 18 20 20

Fax: +33 (0)4 72 18 20 00

China

Shanghai, China

Tel: +86 21 6457 0066

Fax: +86 21 6457 4955

Greater Asia-Pacific

Singapore

Tel: +65 6264 1188

Fax: +65 6862 4040

Regional offices

Americas

Brazil

Alphaville

Mexico

Monterrey

Chile

Santiago

Europe, Middle East,

Africa

France

Baudemont

Cergy

Decines

Germany

Langenfeld

Italy

Lainate

Netherlands

Breda

Poland

Warsaw

Portugal

Baltar

Russia

Moscow

South Africa

Johannesburg

U.A.E.

Dubai

U.K.

Buckingham

China

Beijing

Chengdu

Guangzhou

Xian

Greater Asia-Pacific

Australia

Brisbane

Melbourne

Sydney

India

Chennai

Delhi

Hyderabad

Pune

Korea

Seoul

Philippines

Makati City

Singapore

Factories

Brazil

Passo Fundo

China

TaiAn

Zhangjiagang

France

Charlieu

Moulins

Germany

Wilhelmshaven

India

Pune

Italy

Niella Tanaro

Portugal

Baltar

Fânzeres

USA

Manitowoc

Port Washington

Shady Grove

This document is non-contractual. Constant improvement and engineering progress make it necessary that we reserve the right to make specification, equipment, and price changes without notice. Illustrations shown may include optional equipment and accessories and may not include all standard equipment.