

# National Crane 600H Series

## Product Guide



### Features

- 18,1 t (20 USt) rating
- Six boom options available from 11,58 m (38 ft) to 27,42 m (90 ft)
- Full-, mid-, and retracted-span outriggers
- Mentor LMI System
- Internal anti-two block wiring
- Standard and rear mount options

# Features



## Boom

At 27,5 m (90 ft) the 600H series four-section boom is the longest in its size range. The longer boom allows the operator to perform more lifts without the use of a jib, reducing setup time and improving efficiency. A 11,58 m (38 ft) three-section boom, 15 m (49 ft) four-section boom, 18,3 m (60 ft) three-section boom, 21,64 (71 ft) three-section boom, and 24,38 m (80 ft) four-section boom are also available.

## National Crane Series 600H

- 18,1 t (20 USt) maximum capacity
- 30,2 m (99 ft) maximum tip height (main boom)
- 43,95 m (144 ft) maximum tip height (boom with jib)



## Overload protection

Mentor Load Moment Indicator (LMI) with work area definition system (WADS) is standard on all Series 600H machines. The LMI display console is weatherproof and displays all crane load lifting values simultaneously.

## "HO"-style outriggers

**Standard Mount:** Two sets of "HO"-style outriggers with 5,28 m (17 ft 4 in) span, with 3,04 m (10 ft) mid span setting with manual locks and reduced capacity chart and fully retracted outrigger spread with reduced capacity chart.

**Rear Mount:** 4.7 m (15.3 ft) full span, with 4,05 m (13.3 ft) midspan setting with manual locks and reduced capacity chart and fully retracted outrigger spread with reduced capacity chart.

Main outriggers are equipped with removable ball and socket aluminum foot pads standard.



## Improved serviceability and reliability helps keep you working longer

- Bearings on the boom and retract cables can be greased through access holes in the boom side plates
- Number of internal boom parts has been reduced, decreasing service time
- Internal anti-two-block wire routing eliminates damage potential
- Painting crane components before assembly reduces the possibility of rust and enhances the appearance of the machine
- State of the art control valve provides smoother operation. The new design eliminates parts, reducing repair costs and improving the machines serviceability
- Easy-reeve boom tip and sheave blocks simplify rigging changes by decreasing the time needed to change line reeving

## Performance you can rely on

- The Series 600H is standard with 375° non-continuous rotation
- The optional duty cycle package which includes a burst of speed winch provides faster winch payout and pickup of unloaded cable
- The stronger standard torsion box improves rigidity, reduces truck frame flex and reduces the need for counterweight
- A control knob located on the swing motor brake release valve can be easily adjusted to the crane operator's swing speed preference
- Easy Glide Boom Wear Pads reduce the conditions that cause boom chatter and vibration. The net result is smoother crane operation.



# Contents

Features	2
Mounting configurations	5
Specifications	6
Capacities	7
Dimensions specifications	14
Accessories	15

# Mounting configuration

The configurations are based on the Series 600H with an 85% stability factor. The complete unit must be installed in accordance with factory requirements and a test performed to determine actual stability and counterweight requirements since individual truck chassis vary.

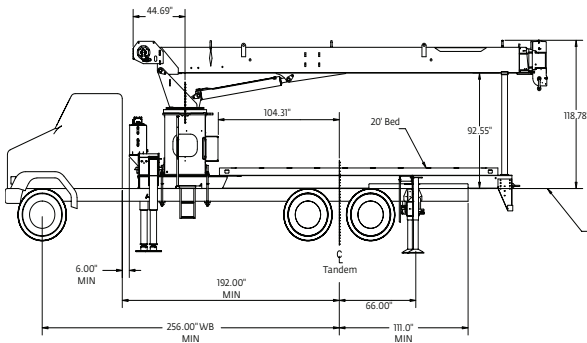

**Configuration 1 with torsion box – 180° full capacity work area**

Working area .....	180°
Gross axle weight rating front .....	6350 kg (14,000 lb)
Gross axle weight rating rear .....	15,442 kg (34,000 lb)
Gross vehicle weight rating .....	21,773 kg (48,000 lb)
Wheelbase .....	650 cm (256 in)
Cab to axle/trunnion (CA/CT) .....	488 cm (192 in)
Frame Section Modulus (SM) under crane:	
758 MPa (110,000 PSI) .....	327,7 cm <sup>3</sup> (20 in <sup>3</sup> )
Frame Section Modulus (SM) over rear stabilizers:	
758 MPa (110,000 PSI) .....	213 cm <sup>3</sup> (13 in <sup>3</sup> )
Stability weight, front .....	3946 kg (8700 lb) minimum*
Stability weight, rear .....	3901 kg (8600 lb) minimum*

This configuration is the least expensive method for the Model 600H. This mount, with the crane mounted behind the cab, requires the least weight of all mounts for stability; thus, you can haul larger payloads on your truck. It requires standard subbase and rear (ASH) stabilizers. \*Weights do not include RSOD, PTO, pumpt, bed and SFO.

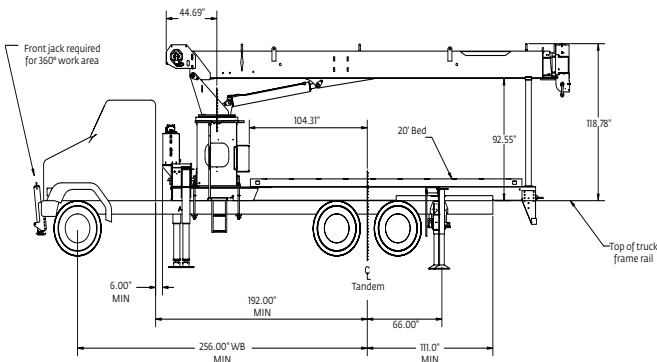

**Configuration 2 with torsion box – 360° full capacity work area**

Working area .....	360°
Gross axle weight rating front .....	6350 kg (14,000 lb)
Gross axle weight rating rear .....	15,422 kg (34,000 lb)
Gross vehicle weight rating .....	21,773 kg (48,000 lb)
Wheelbase .....	650 cm (256 in)
Cab to axle/trunnion (CA/CT) .....	488 cm (192 in)
Frame Section Modulus (SM) under crane:	
758 MPa (110,000 PSI) .....	328 cm <sup>3</sup> (20 in <sup>3</sup> )
Frame Section Modulus (SM) over rear stabilizers:	
758 MPa (110,000 PSI) .....	213 cm <sup>3</sup> (13 in <sup>3</sup> )
Stability weight, front .....	3946 kg (8700 lb) minimum*
Stability weight, rear .....	3901 kg (8600 lb) minimum*

Requires front SFO stabilizer to give machine full capacity 360° around the truck. Truck must meet the minimum requirements above. Front stabilizer gives the machine a solid base, helping the operator control loads precisely. Extended front frame rails required for SFO installation. \*Weights do not include RSOD, PTO, pumpt, bed and SFO.

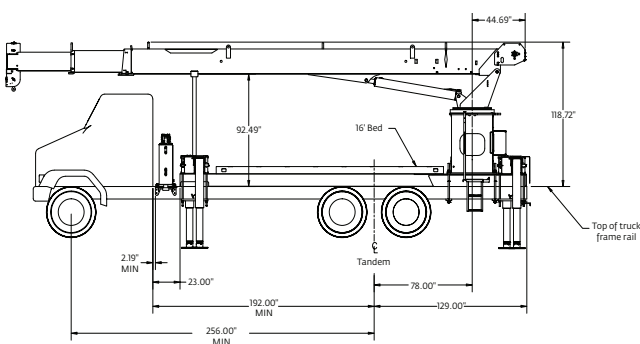

**Configuration 3 with torsion box – rear mount**

Working area .....	360°
Gross axle weight rating front .....	5443 kg (12,000 lb)
Gross axle weight rating rear .....	15,422 kg (34,000 lb)
Gross vehicle weight rating .....	20,865 kg (46,000 lb)
Wheelbase .....	650 cm (256 in)
Cab to axle/trunnion (CA/CT) .....	488 cm (192 in)
Frame Section Modulus (SM) under crane:	
758 MPa (110,000 PSI) .....	261 cm <sup>3</sup> (15.9 in <sup>3</sup> )
Frame Section Modulus (SM) over rear stabilizers:	
758 MPa (110,000 PSI) .....	261 cm <sup>3</sup> (15.9 in <sup>3</sup> )
Stability weight, front .....	2948 kg (6500 lb) minimum*
Stability weight, rear .....	4309 kg (9500 lb) minimum*

Allows the installation of the Model 600H on a chassis. In most cases, the chassis will not require reinforcing, and the amount of counterweight required is minimized, increasing payload capacities. \*Weights do not include RSOD, PTO, pumpt, bed and SFO.

**Notes:**

- Gross Vehicle Weight rating (GVWR) is dependent on all components of the vehicle (axles, tires, springs, frame, etc.) meeting manufacturers' recommendations: always specify GVWR when purchasing trucks
- Diesel engines require a variable speed governor and energize-to-run fuel solenoid for smooth crane operation; electronic fuel injection requires EET engine remote throttle

- All mounting data is based on a National Series 600H with an 85 percent stability factor
- The complete unit must be installed in accordance with factory requirements, and a test performed to determine actual stability and counterweight requirements per SAE J765; contact the factory for details
- Transmission neutral safety interlock switch is required with optional radio remote control

\*Estimated axle scale rates prior to installation of crane, stabilizers and subbase for 85% stability.

# Specifications

## Boom and jib combinations data

Available in six basic models.

**Model 638H** – Equipped with a 4,88 m - 11,58 m (16 ft - 38 ft) three-section boom. Maximum tip height is 14,63 m (48 ft) (no jib option available).

4,88 m - 11,58 m (16 ft - 38 ft) three-section boom



**Model 649H** – Equipped with a 4,88 m - 15 m (16 ft - 49 ft) four-section boom. Maximum tip height is 17,98 m (59 ft). (no jib option available).

4,88 m - 15 m (16 ft - 49 ft) four-section boom



**Model 660H** – Equipped with a 7,32 m - 18,3 m (24 ft - 60 ft) three-section boom. Maximum tip height is 21,3 m (70 ft) (no jib option available).

7,32 m - 18,3 m (24 ft - 60 ft) three-section boom



**Model 671H** – Equipped with a 8,23 m - 21,64 m (27 ft - 71 ft) three-section boom. This model can be equipped with a 7,62 m - 13,72 m (25 ft - 45 ft) two-section jib. Maximum tip height with 13,72 m (45 ft) jib is 38,25 m (125 ft).

8,23 m - 21,64 m (27 ft - 71 ft) three-section boom      **6FJ45M** 7,62 m - 13,72 m (25 ft - 45 ft) two-section jib



**Model 680H** – Equipped with a 7,32 m - 24,38 m (24 ft - 80 ft) four-section boom. Maximum tip height is 27,44 m (90 ft) (no jib option available).

7,32 m - 24,38 m (24 ft - 80 ft) four-section boom



**Model 690H** – Equipped with a 8,23 m - 27,43 m (27 ft - 90 ft) four-section boom. This model can be equipped with a 7,62 m - 13,72 m (25 ft - 45 ft) two section jib. Maximum tip height with 13,72 m (45 ft) jib is 43,95 m (144 ft).

8,23 m - 27,43 m (27 ft - 90 ft) four-section boom      **6FJ45M** 7,62 m - 13,72 m (25 ft - 45 ft) two-section jib



Note: Maximum tip is measured with outriggers/stabilizers fully extended.

# Capacities

## 600H Winch Data

- All winch pulls and speeds in this chart are shown on the fourth layer
- Winch line pulls would increase on the first and second layers
- Winch line pulls may be limited by the winch capacity or the ANSI 5 to 1 cable safety factor, shown below this chart
- Hook blocks are rated at maximum capacity for the block. Do not exceed rated cable pull with any block.

Winch	Cable supplied	Minimum breaking strength	1 part line	2 part line	3 part line	4 part line	5 part line	6 part line
			Max. pull	Max. pull	Max. pull	Max. pull	Max. pull	Max. pull
Standard planetary winch	9/16" diameter rotation resistant	17 463 kg (38,500 lb)	3493 kg (7700 lb)	6985 kg (15,400 lb)	10 478 kg (23,100 lb)	13 971 kg (30,800 lb)	17 463 kg (38,500 lb)	18 144 kg (40,000 lb)

Layer	Winch pull		Winch speed		BOS winch speed		Rope capacity	
	kg	lb	mpm	fpm	mpm	fpm	m	ft
1	4708	10,380	48	157	68	222	19	64
2	4246	9360	53	175	75	246	41	136
3	3865	8520	59	192	83	271	65	215
4	3547	7820	64	209	90	294	91	301
5	3279	7230	78	257	97	318	120	394

NOTE: All ratings based on 128,7 LPM at 22,75 MPa (34 GPM at 3300 psi). Burst of speed maximum pull = 1361 kg (3000 lb)

Winch	Bare drum pull	Allowable cable pull
With standard rotation resistant rope	4627 kg (10,200 lb)	3493 kg (7700 lb)

Block Type	Rating	Weight
Downhaul Weight	6,4 t (7 USt)	78 kg (171 lb)
1 Sheave Block	11,3 t (12.5 USt)	91 kg (200 lb)
2 Sheave Block	20 t (22 USt)	161 kg (355 lb)

# Capacities

## 638H: 11,58 m (38 ft) boom with full span outriggers, no jib

Other Series 600H load rating charts are available. National Crane will send you a chart on request – or you may secure needed load rating information through your nearest National Crane dealer.

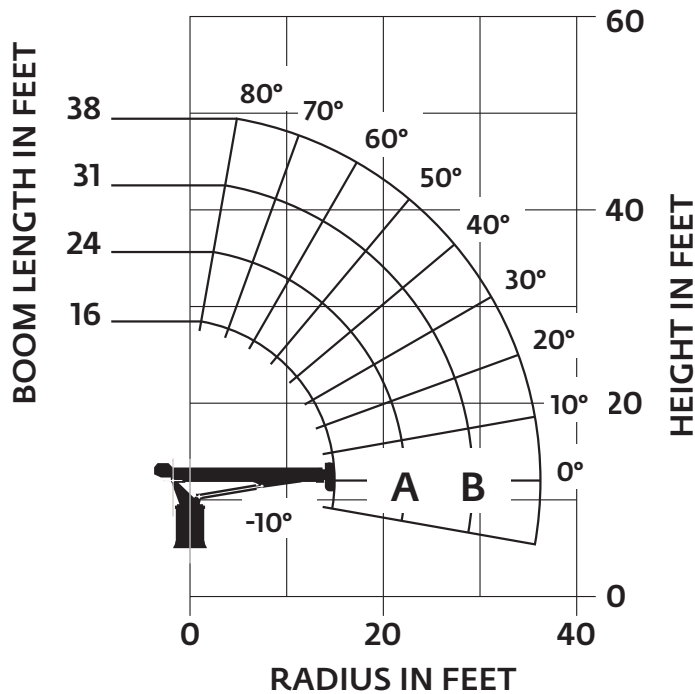

### CAUTION:

- Do not operate crane booms, jib extensions, any accessories or loads within 3 m (10 ft) of live power lines or other conductors of electricity.
- Jib and boom capacities shown are maximum for each section.
- Do not exceed capacities at reduced radii.
- Load ratings shown on the appropriate charts are maximum allowable loads with the crane mounted on a factory-approved truck and all outriggers at either full span or at mid span range and set on a firm level surface so that the crane is level and all tires are suspended.
- Always level the crane with the level indicator located on the crane.
- The operator must reduce load to allow for factors such as wind, ground conditions, operating speeds and their effects on freely suspended loads.
- Overloading this crane may cause structural collapse or instability.
- Weights on any accessories attached to the boom or loadline must be deducted from the load chart capacities.
- Do not deadhead lineblock against boom tip when extending boom or winching up.
- Keep at least three wraps of loadline on drum at all times.
- Use only specified cable with this machine.

### Load chart

LOADED RADIUS (FT)	LOADED BOOM ANGLE (DEG)	16 FT BOOM (LB)	LOADED BOOM ANGLE (DEG)	A 24 FT BOOM (LB)	LOADED BOOM ANGLE (DEG)	B 31 FT BOOM (LB)	LOADED BOOM ANGLE (DEG)	38 FT BOOM (LB)
5	67	40,000						
6	63	36,150						
8	55.5	30,250	68	28,550	74	27,500	77	25,750
10	45.5	25,600	62.5	24,300	69	23,450	73	22,200
12	34	21,900	56.5	20,900	65	20,150	70.5	19,200
14	15	16,750	50	18,150	60.5	17,800	66.5	17,050
16			43	16,200	56	15,800	64.5	15,200
18			34.5	14,200	51.5	14,150	59.5	13,750
20			26.5	12,200	47	12,900	57	12,500
25					31.5	10,150	46	9950
30							35.5	8350
35							18.5	6200
	0	10,850	0	7050	0	5100	0	3850

\* Shaded areas are structurally limited capacities.

THIS CHART IS ONLY A GUIDE AND SHOULD NOT BE USED TO OPERATE THE CRANE.

The individual crane's load chart, operating instructions and other instructional plates must be read and understood prior to operating the crane.

Courtesy of Crane.Market



# Capacities

## 649H: 15 m (49 ft) boom with full span outriggers, no jib

Other Series 600H load rating charts are available. National Crane will send you a chart on request – or you may secure needed load rating information through your nearest National Crane dealer.

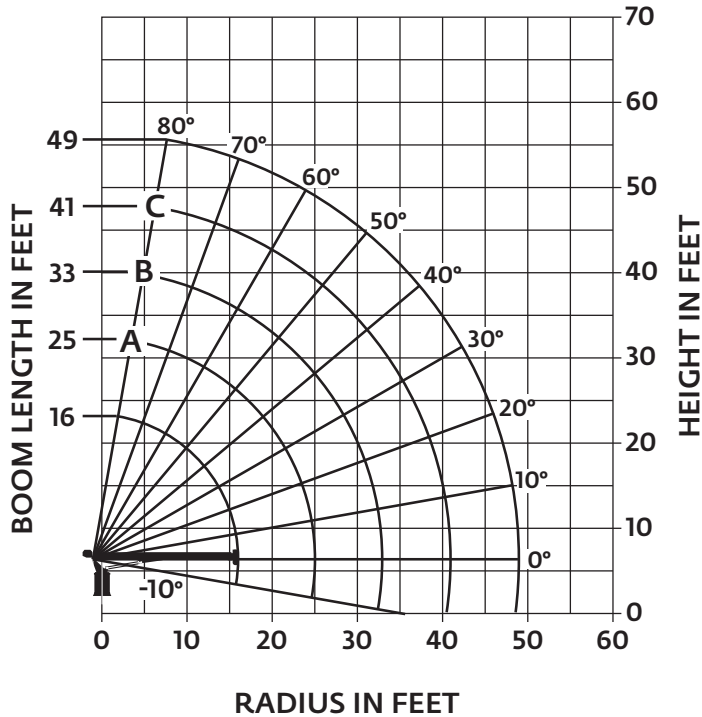

### CAUTION:

- Do not operate crane booms, jib extensions, any accessories or loads within 3 m (10 ft) of live power lines or other conductors of electricity.
- Jib and boom capacities shown are maximum for each section.
- Do not exceed capacities at reduced radii.
- Load ratings shown on the appropriate charts are maximum allowable loads with the crane mounted on a factory-approved truck and all outriggers at either full span or at mid span range and set on a firm level surface so that the crane is level and all tires are suspended.
- Always level the crane with the level indicator located on the crane.
- The operator must reduce load to allow for factors such as wind, ground conditions, operating speeds and their effects on freely suspended loads.
- Overloading this crane may cause structural collapse or instability.
- Weights on any accessories attached to the boom or loadline must be deducted from the load chart capacities.
- Do not deadhead lineblock against boom tip when extending boom or winching up.
- Keep at least three wraps of loadline on drum at all times.
- Use only specified cable with this machine.

### Load chart

LOADED RADIUS (ft)	LOADED BOOM ANGLE (deg)	16 FT BOOM (lb)	LOADED BOOM ANGLE (deg)	A 25 FT BOOM (lb)	LOADED BOOM ANGLE (deg)	B 33 FT BOOM (lb)	LOADED BOOM ANGLE (deg)	C 41 FT BOOM (lb)	LOADED BOOM ANGLE (deg)	49 FT BOOM (lb)
5	67	40,000	75.5	38,100						
8	54	29,600	68	27,400	74	26,200	77.5	25,300		
10	44	24,700	63	23,200	70	22,200	74.5	21,300	78	19,500
12	31.5	20,400	57.5	20,200	66.5	19,250	71.5	18,450	75.5	17,500
14	8	13,750	51.5	17,750	62.5	17,000	68.5	16,300	73	15,000
16			45	15,750	58	15,200	65.5	14,550	70.5	13,750
20			29	12,100	49.5	12,500	59	12,050	65	11,750
25					36	9850	50	9800	58.5	9600
30					17	6950	40	8050	51	8050
35							28	6450	43.5	6800
40									33.5	5650
45									19	4300
	0	10,950	0	6350	0	4350	0	3200	0	2600

\* Shaded areas are structurally limited capacities.

THIS CHART IS ONLY A GUIDE AND SHOULD NOT BE USED TO OPERATE THE CRANE.

# Capacities

## 660H: 18,3 m (60 ft) boom with full span outriggers, no jib

Other Series 600H load rating charts are available. National Crane will send you a chart on request – or you may secure needed load rating information through your nearest National Crane dealer.

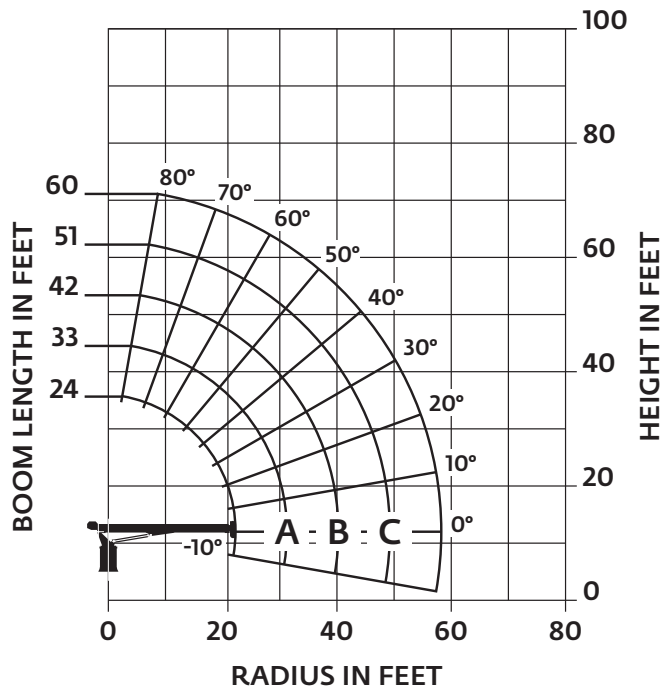

### CAUTION:

- Do not operate crane booms, jib extensions, any accessories or loads within 3 m (10 ft) of live power lines or other conductors of electricity.
- Jib and boom capacities shown are maximum for each section.
- Do not exceed capacities at reduced radii.
- Load ratings shown on the appropriate charts are maximum allowable loads with the crane mounted on a factory-approved truck and all outriggers at either full span or at mid span range and set on a firm level surface so that the crane is level and all tires are suspended.
- Always level the crane with the level indicator located on the crane.
- The operator must reduce load to allow for factors such as wind, ground conditions, operating speeds and their effects on freely suspended loads.
- Overloading this crane may cause structural collapse or instability.
- Weights on any accessories attached to the boom or loadline must be deducted from the load chart capacities.
- Do not deadhead lineblock against boom tip when extending boom or winching up.
- Keep at least three wraps of loadline on drum at all times.
- Use only specified cable with this machine.

### Load chart

LOADED RADIUS (ft)	LOADED BOOM ANGLE (deg)	24 FT BOOM (lb)	LOADED BOOM ANGLE (deg)	A 33 FT BOOM (lb)	LOADED BOOM ANGLE (deg)	B 42 FT BOOM (lb)	LOADED BOOM ANGLE (deg)	C 51 FT BOOM (lb)	LOADED BOOM ANGLE (deg)	60 FT BOOM (lb)
5	75.5	40,000								
8	67.5	27,200	74	25,800	77.5	25,000				
10	62	22,800	70	21,600	75	20,700	78	20,400		
12	56	19,650	67	18,700	72	17,800	75.5	17,400	78.5	17,150
14	49.5	17,150	62.5	16,400	69	15,750	73	15,250	76.5	14,950
16	43	15,150	58.5	14,600	66	14,050	71	13,600	74.5	13,200
20	24.5	11,150	49.5	11,950	60	11,550	66	11,200	70.5	10,850
25			37.5	9400	51.5	9350	59.5	9100	65.5	8800
30			14.5	6600	42	7700	53	7600	60	7400
35					30.5	6100	45.5	6400	54.5	6200
40							36.5	5350	48	5400
45							25	4250	41	4550
50									33	3900
55									21.5	3000
	0	6150	0	3950	0	2700	0	1950	0	1300

\* Shaded areas are structurally limited capacities.

THIS CHART IS ONLY A GUIDE AND SHOULD NOT BE USED TO OPERATE THE CRANE.

The individual crane's load chart, operating instructions and other instructional plates must be read and understood prior to operating the crane.

Courtesy of Crane.Market

# Capacities

## 671H: 21,6 m (71 ft) boom with 13,7 m (45 ft) jib and full span outriggers

Other Series 600H load rating charts are available. National Crane will send you a chart on request – or you may secure needed load rating information through your nearest National Crane dealer.

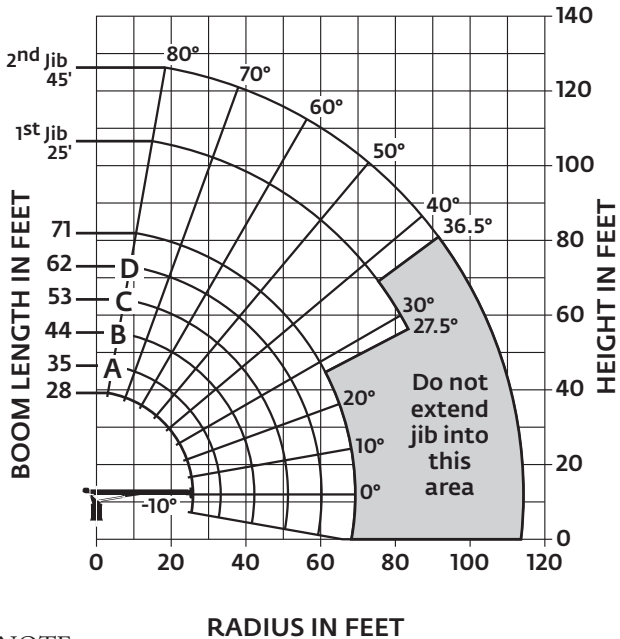

### CAUTION:

- Do not operate crane booms, jib extensions, any accessories or loads within 3 m (10 ft) of live power lines or other conductors of electricity.
- Jib and boom capacities shown are maximum for each section.
- Do not exceed capacities at reduced radii.
- Load ratings shown on the appropriate charts are maximum allowable loads with the crane mounted on a factory-approved truck and all outriggers at either full span or at mid span range and set on a firm level surface so that the crane is level and all tires are suspended.
- Always level the crane with the level indicator located on the crane.
- The operator must reduce load to allow for factors such as wind, ground conditions, operating speeds and their effects on freely suspended loads.
- Overloading this crane may cause structural collapse or instability.
- Weights on any accessories attached to the boom or loadline must be deducted from the load chart capacities.
- Do not deadhead lineblock against boom tip when extending boom or winching up.
- Keep at least three wraps of loadline on drum at all times.
- Use only specified cable with this machine.

### NOTE:

1. Operate with jib by radius when main boom is fully extended. If necessary increase boom angle to maintain loaded radius.
2. Operate with jib by boom angle when main boom is not fully extended. Do not exceed rated jib capacities at any reduced boom lengths.

### Load chart

LOADED RADIUS (ft)	LOADED BOOM ANGLE (deg)	28 FT BOOM (lb)	LOADED BOOM ANGLE (deg)	A 35 FT BOOM (lb)	LOADED BOOM ANGLE (deg)	B 44 FT BOOM (lb)	LOADED BOOM ANGLE (deg)	C 53 FT BOOM (lb)	LOADED BOOM ANGLE (deg)	D 62 FT BOOM (lb)	LOADED BOOM ANGLE (deg)	71 FT BOOM (lb)
5	77	40,000										
8	70.5	25,550	75	24,750	78.5	24,250						
10	65.5	21,000	71.5	21,000	76	20,450	79	20,100				
12	61	17,900	68	17,950	73	17,450	76.5	17,150	79	16,550		
14	56	16,000	64.5	15,550	70.5	15,500	74.5	15,000	77	14,400	79	12,450
16	50.5	14,900	60.5	13,700	67.5	13,650	72	13,250	75	12,750	77.5	12,450
20	38	11,300	52.5	11,100	61.5	10,950	67	10,700	71	10,350	74	10,050
25	19.5	7650	40.5	8900	53.5	8700	61	8500	66	8300	69.5	8050
30			26	6600	45.5	7100	55	7000	61	6850	65.5	6600
35					35	5800	48	5850	55.5	5750	61	5700
40					20	4100	40	4900	49.5	4850	56	4800
45							29.5	4050	43	4050	51	4150
50							14	2450	35	3400	45.5	3550
55									25.5	2700	39	3000
60									10	1500	31.5	2500
65											22	1900
	0	4200	0	3100	0	1850	0	1150	0	650		

### 25 ft-45 ft JIB FULL SPAN RATED LOADS

LOADED RADIUS (ft)	LOADED BOOM ANGLE (deg)	25 ft JIB (lb)	LOADED BOOM ANGLE (deg)	44 ft JIB (lb)
25	75.5	4400		
30	72.5	3900	76.5	2600
35	69	3200	74	2450
40	66	2750	72	2300
45	62.5	2350	69	2100
50	59.5	2000	66.5	1900
55	55.5	1750	64	1700
60	52	1500	61	1500
65	48	1300	58.5	1350
70	43.5	1100	55	1200
75	39	900	52	1050
80	33.5	700	48.5	900
85	27.5	600	45	800
90			41	700
95			36.5	600

\* Shaded areas are structurally limited capacities.

THIS CHART IS ONLY A GUIDE AND SHOULD NOT BE USED TO OPERATE THE CRANE.

The individual crane's load chart, operating instructions and other instructional plates must be read and understood prior to operating the crane.

# Capacities

## 680H: 23,4 m (80 ft) boom with full span outriggers, no jib

Other Series 600H load rating charts are available. National Crane will send you a chart on request – or you may secure needed load rating information through your nearest National Crane dealer.

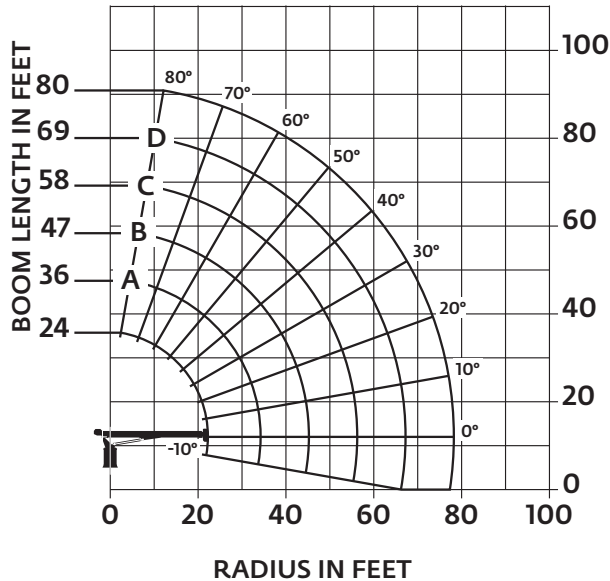

### CAUTION:

- Do not operate crane booms, jib extensions, any accessories or loads within 3 m (10 ft) of live power lines or other conductors of electricity.
- Jib and boom capacities shown are maximum for each section.
- Do not exceed capacities at reduced radii.
- Load ratings shown on the appropriate charts are maximum allowable loads with the crane mounted on a factory-approved truck and all outriggers at either full span or at mid span range and set on a firm level surface so that the crane is level and all tires are suspended.
- Always level the crane with the level indicator located on the crane.
- The operator must reduce load to allow for factors such as wind, ground conditions, operating speeds and their effects on freely suspended loads.
- Overloading this crane may cause structural collapse or instability.
- Weights on any accessories attached to the boom or loadline must be deducted from the load chart capacities.
- Do not deadhead lineblock against boom tip when extending boom or winching up.
- Keep at least three wraps of loadline on drum at all times.
- Use only specified cable with this machine.

### Load chart

LOADED RADIUS (ft)	LOADED BOOM ANGLE (deg)	24 FT BOOM (lb)	LOADED BOOM ANGLE (deg)	A 36 FT BOOM (lb)	LOADED BOOM ANGLE (deg)	B 47 FT BOOM (lb)	LOADED BOOM ANGLE (deg)	C 58 FT BOOM (lb)	LOADED BOOM ANGLE (deg)	D 69 FT BOOM (lb)	LOADED BOOM ANGLE (deg)	80 FT BOOM (lb)
5	76	40,000										
8	68	27,100	75	25,400								
10	62.5	22,400	72	21,400	76.5	20,600						
12	56.5	19,500	68.5	18,350	74	17,550	77.5	17,050				
14	50.5	17,100	65	16,000	71.5	15,300	75.5	14,750				
16	43.5	14,750	61	14,200	70	13,550	73.5	13,050	77	12,150		
20	27	11,100	53.5	11,450	63.5	11,000	69.5	10,550	73.5	10,100	77	8550
25			43	9150	55.5	9000	64	8450	69	8200	73	8000
30			29.5	7000	48	7200	58.5	7050	64.5	6850	69	6550
35					39	5850	52	5900	59.5	5700	65	5500
40					28	4650	45	4800	54.5	4850	61	4650
45					7.5	2600	37	4100	49	4150	56.5	4000
50							28	3450	43	3500	52	3450
55							13.5	2200	36	2950	47	3000
60									28	2450	41.5	2550
65									16	1550	35.5	2150
70											28.5	1700
75											18.5	1150
	0	5800	0	3050	0	1750	0	1000				

\* Shaded areas are structurally limited capacities.

THIS CHART IS ONLY A GUIDE AND SHOULD NOT BE USED TO OPERATE THE CRANE.

The individual crane's load chart, operating instructions and other instructional plates must be read and understood prior to operating the crane.

Courtesy of Crane.Market

# Capacities

## 690H: 27.4 m (90 ft) boom with 13.7 m (45 ft) jib and full span outriggers

Other Series 600H load rating charts are available. National Crane will send you a chart on request – or you may secure needed load rating information through your nearest National Crane dealer.

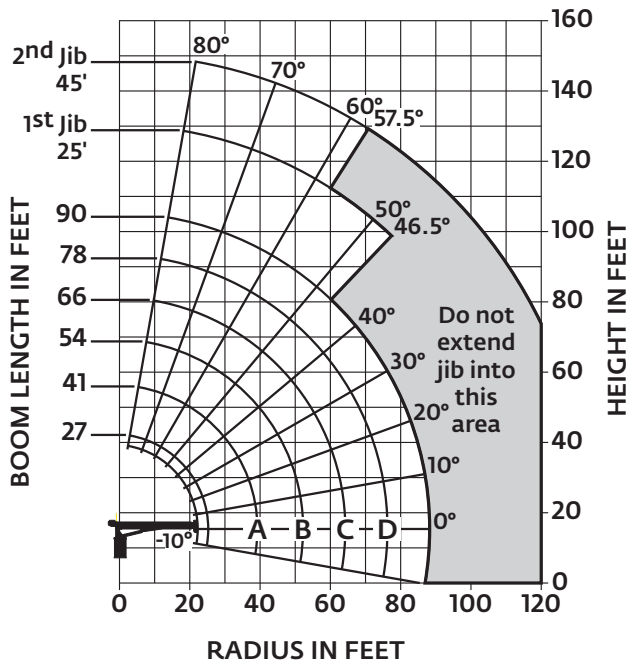

### CAUTION:

- Do not operate crane booms, jib extensions, any accessories or loads within 3 m (10 ft) of live power lines or other conductors of electricity.
- Jib and boom capacities shown are maximum for each section.
- Do not exceed capacities at reduced radii.
- Load ratings shown on the appropriate charts are maximum allowable loads with the crane mounted on a factory-approved truck and all outriggers at either full span or at mid span range and set on a firm level surface so that the crane is level and all tires are suspended.
- Always level the crane with the level indicator located on the crane.
- The operator must reduce load to allow for factors such as wind, ground conditions, operating speeds and their effects on freely suspended loads.
- Overloading this crane may cause structural collapse or instability.
- Weights on any accessories attached to the boom or loadline must be deducted from the load chart capacities.
- Do not deadhead lineblock against boom tip when extending boom or winching up.
- Keep at least three wraps of loadline on drum at all times.
- Use only specified cable with this machine.

### NOTE:

1. Operate with jib by radius when main boom is fully extended. If necessary increase boom angle to maintain loaded radius.
2. Operate with jib by boom angle when main boom is not fully extended. Do not exceed rated jib capacities at any reduced boom lengths.

### Load chart

LOADED RADIUS (ft)	LOADED BOOM ANGLE (deg)	27 FT BOOM (lb)	LOADED BOOM ANGLE (deg)	A 41 FT BOOM (lb)	LOADED BOOM ANGLE (deg)	B 54 FT BOOM (lb)	LOADED BOOM ANGLE (deg)	C 66 FT BOOM (lb)	LOADED BOOM ANGLE (deg)	D 78 FT BOOM (lb)	LOADED BOOM ANGLE (deg)	90 FT BOOM (lb)
5	77	40,000										
8	70	25,750										
10	66	21,400	74	20,950								
12	61.5	18,450	71	17,750	76	17,000						
14	57	16,400	68	15,250	74	15,000	77.5	14,450				
16	51	14,750	65.5	13,300	71.5	13,200	75.5	12,600				
20	40	11,250	58.5	10,800	67.5	10,500	72	9950	76	9700	77.5	7850
25	19	7500	50	9050	61.5	8150	67	7900	71.5	7750	74.5	7550
30			40	7550	55	6750	62.5	6450	68	6250	71.5	6150
35			26.5	5250	48	5700	58	5450	63.5	5200	68	5050
40					40	4600	52	4550	59.5	4400	64.5	4200
45					32	3850	46.5	3850	54.5	3700	61	3550
50					16.5	2450	39.5	3150	50	3150	57	3000
55							31	2550	44.5	2650	53.0	2550
60							21.5	1800	39.5	2250	48.5	2150
65									32.5	1750	44	1850
70									24	1250	39	1500
75									11	450	33	1150
80											26.5	800
	0	4150	0	1950	0	850						

25 ft–45 ft JIB FULL SPAN RATED LOADS				
LOADED RADIUS (ft)	LOADED BOOM ANGLE (deg)	25 ft JIB (lb)	LOADED BOOM ANGLE (deg)	45 ft JIB (lb)
25	78	2600		
30	75.5	2500	78.5	1700
35	73	2200	76.5	1500
40	70	1900	74	1350
45	67.5	1600	72	1100
50	65.5	1400	70	1000
55	62.5	1200	67.5	900
60	59.5	1000	65.5	800
65	56.5	800	63	700
70	53.5	700	60.5	600
75	50	600	58	500
80	47	500		

\* Shaded areas are structurally limited capacities.

THIS CHART IS ONLY A GUIDE AND SHOULD NOT BE USED TO OPERATE THE CRANE.

# Dimensions

## Standard mount

Series	G	H	Dry weight*	w/oil weight*
638H	123 cm (48.43 in)	116 cm (45.81 in)	6301 kg (13,891 lb)	6632 kg (14,622 lb)
649H	141 cm (55.32 in)	123 cm (48.38 in)	6590 kg (14,529 lb)	6937 kg (15,294 lb)
660H	168 cm (66.09 in)	128 cm (50.55 in)	6857 kg (15,116 lb)	7218 kg (15,912 lb)
671H	176 cm (69.29 in)	134 cm (52.92 in)	7174 kg (15,816 lb)	7557 kg (16,659 lb)
680H	165 cm (64.93 in)	142 cm (55.95 in)	7365 kg (16,236 lb)	7752 kg (17,090 lb)
690H	197 cm (77.45 in)	153 cm (60.08 in)	8007 kg (17,653 lb)	8398 kg (18,515 lb)

"H" style rear stabilizers
with oil weight
672 kg (1481 lb)

\* ABOVE WEIGHTS DO NOT INCLUDE RESERVOIR, RSOD, JIB, PTO, PUMP, BED

\*\* WEIGHT INCLUDES BOOM, WINCH, ROPE, TURRET, LIFT CYLINDER, FRAME, CONTROLS, OUTRIGGERS, PLATFORMS, TORQUE BOX, BOOM REST, BUMPER, DOWNHAUL WEIGHT

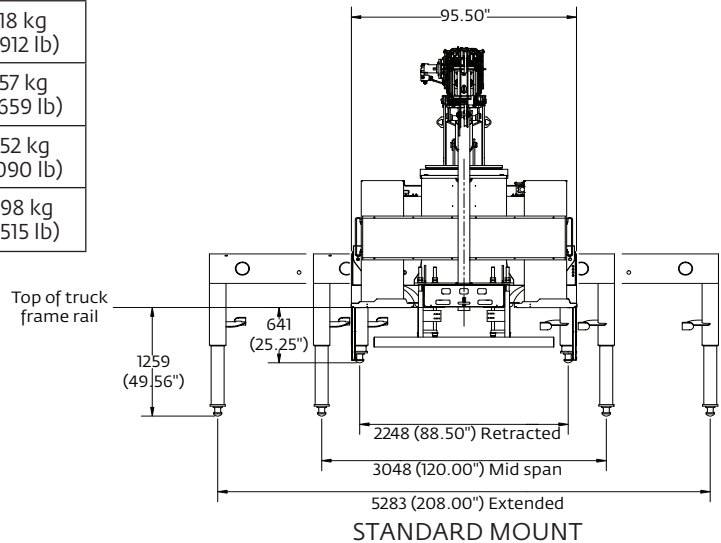

R 1152 (45.34") tail swing

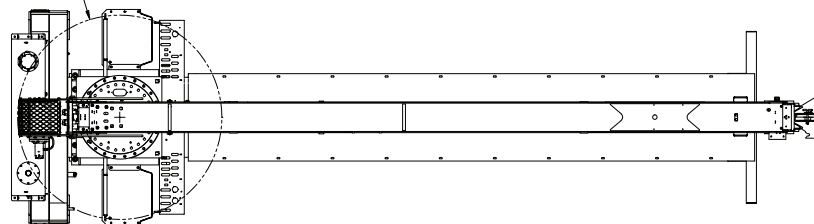

638H	649H	660H
5055 (16' - 7") Retracted	4978 (16' - 4") Retracted	7264 (23' - 10") Retracted
11 582 (38' - 0") Extended	14 935 (49' - 0") Extended	18 339 (60' - 2") Extended
671H	680H	690H
8407 (27' - 7") Retracted	7315 (24' - 0") Retracted	8484 (27' - 10") Retracted
21 641 (71' - 0") Extended	24 384 (80' - 0") Extended	27 432 (90' - 0") Extended

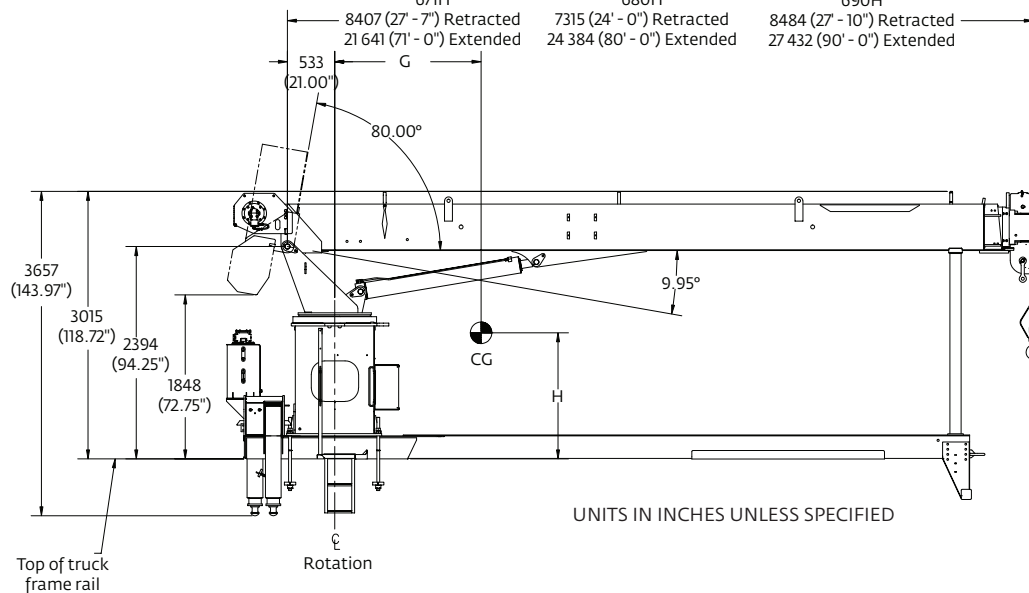

# Accessories

## **Radio Remote Controls –**

Eliminate the handling and maintenance concerns that accompany cabled remotes. Operate to a range of about 76 m (250 ft), varying with conditions.

## **Heavy-duty Personnel Basket –**

544 kg (1200 lb) capacity steel basket with safety loops for two passengers. Gravity leveling 183 cm x 107 cm (72 in x 42 in) platform. Fast attachment and secure locking systems. Load chart must show 1043 kg (2300 lb) minimum to operate this accessory.

## **Duty Cycle Package –**

Burst of speed winch (BOS) control option, hydraulic oil cooler (OC), and self-contained radiator system with electric fan.

## **Single Front Outrigger –**

Center front stabilizer with a 25 in vertical stroke

## **Bulkhead-steel**

## **Boom mounted hose reel**

With control valve and hydraulic hoses

## **Spanish-Language Danger Decals,**

## **Spanish Operators' Manuals**

- **RB4R**
  
- **BSA-1**
- **BSA-R1 (provides rotation)**
  
- **DCPKG**
  
- **SFO**
  
- **BHSD**
  
- **CRH**
  
- **SDD**
  
- **SOM**

## Manitowoc Cranes

### Regional headquarters

#### Americas

**Manitowoc, Wisconsin, USA**

Tel: +1 920 684 6621

Fax: +1 920 683 6277

**Shady Grove, Pennsylvania, USA**

Tel: +1 717 597 8121

Fax: +1 717 597 4062

#### Europe, Middle East, Africa

**Dardilly, France**

Tel: +33 (0)4 72 18 20 20

Fax: +33 (0)4 72 18 20 00

#### China

**Shanghai, China**

Tel: +86 21 6457 0066

Fax: +86 21 6457 4955

#### Greater Asia-Pacific

**Singapore**

Tel: +65 6264 1188

Fax: +65 6862 4040

### Regional offices

#### Americas

**Brazil**

Alphaville

**Mexico**

Monterrey

**Chile**

Santiago

#### Europe, Middle East,

**Africa**

**France**

Baudemont

Cergy

Decines

**Germany**

Langenfeld

**Italy**

Lainate

**Netherlands**

Breda

**Poland**

Warsaw

**Portugal**

Baltar

**Russia**

Moscow

**South Africa**

Johannesburg

**U.A.E.**

Dubai

**U.K.**

Buckingham

#### China

Beijing

Chengdu

Guangzhou

Xian

#### Greater Asia-Pacific

**Australia**

Brisbane

Melbourne

Sydney

**India**

Chennai

Delhi

Hyderabad

Pune

**Korea**

Seoul

**Philippines**

Makati City

**Singapore**

### Factories

**Brazil**

Passo Fundo

**China**

TaiAn

Zhangjiagang

**France**

Charlieu

Moulins

**Germany**

Wilhelmshaven

**India**

Pune

**Italy**

Niella Tanaro

**Portugal**

Baltar

Fânzeres

**USA**

Manitowoc

Port Washington

Shady Grove

This document is non-contractual. Constant improvement and engineering progress make it necessary that we reserve the right to make specification, equipment, and price changes without notice. Illustrations shown may include optional equipment and accessories and may not include all standard equipment.