



NEW HOLLAND

**L150 L160 L170 L175 L180 L185 L190
SUPER BOOM® SKID STEER LOADERS**

- Increase Productivity with the Super Boom® Design
- Best in Class Cab Comfort
- Easy Service Access and Attachment Changes
- Superior All Around Visibility
- Comfortable Controls for Easy Operation

BUILT AROUND YOU

Courtesy of Machine.Market

Built Around You

No matter what your line of work—construction, landscaping, demolition or farming—you'll complete your jobs more effectively with a New Holland skid steer. The innovative Super Boom® design lets you do more in less time. Our team of engineers works closely with valued customers and dealers to continually bring vital enhancements to our industry-leading skid steers.

- Patented, vertical-lift Super Boom design increases productivity by providing high lift capacities, long forward dump reach, and fast cycle times.
- Super Boom cab offers comfortable controls, comfortable operator environment, and excellent all around visibility for operator productivity and safety.
- Optimum stability with long wheelbase and low center of gravity.
- Super Boom skid steers are reliable workhorses that stand up to any challenge you face.
- New Holland offers pilot controls to improve productivity and comfort.
- Easy access serviceability and attachment changes.

There's no stopping the productivity of a Super Boom skid steer! Put the New Holland advantages to work for you.

Lift Your Productivity with a Super Boom®

Patented, vertical-lift Super Boom design increases productivity by providing high lift capacities, long forward dump reach, and fast cycle times.

- Fast cycle times for greater productivity.
- Boom design places weight of load between tires for greater stability.
- Excellent line of sight to bucket when loader arms are raised.
- Maximum hinge pin clearance provides more forward reach than radial lift designs to more effectively fill high sided trucks and hoppers.
- Steep dump angles allow the bucket to dump completely, allowing even the stickiest material to fall out.
- Vertical lifting keeps the load closer throughout the lift cycle.

	Max. SAE Gross (diesel engine) hp (kW)		SAE Operating Load lbs (kg)		SAE Operating Weight lbs (kg)		SAE Dump Height in (mm)		SAE DUMP REACH (at max. height), in (mm)	
L150	38	(28.4)	1,350	(612)	4,500	(2,042)	92.2	(2,341)	19.88	(505)
L160	46	(34.3)	1,600	(726)	5,534	(2,510)	93.3	(2,371)	27.9	(709)
L170	52	(39.3)	1,765	(801)	5,540	(2,513)	93.3	(2,371)	27.9	(709)
L175	60	(45)	2,000	(907)	6,230	(2,826)	95.6	(2,428)	27.7	(703)
L180	74	(55)	2,200	(998)	7,130	(3,234)	101.2	(2,569)	33.1	(840)
L185	82	(61)	2,500	(1,134)	7,135	(3,236)	101.2	(2,569)	33.1	(840)
L190	90	(67)	2,800	(1,270)	7,765	(3,522)	102.8	(2,611)	31.7	(806)

The New Holland advantage:

New Holland vertical lift Super Boom design has more forward reach than radial lift designs which allows the New Holland skid steer to load material into the center of the truck!

A Point of View

Operator efficiency begins with operator comfort, and your operators get comfort without compromise in the new deluxe Super Boom cab. The deluxe cab on skid steer models L150 through L190 breaks new ground when it comes to dimensions, visibility, and ease of operation. It expands your view of the world, while expanding your work site efficiency.

Excellent Visibility

- Enhanced downward sight lines provide a better view to the loader bucket and into the trench.
- Rear visibility is one of the best in the industry due to the large rear window, low engine hood and no rear frame towers to block your view.
- The deluxe cab enclosure includes a repositioned windshield wiper for a clearer view in all conditions.
- On enclosed cabs, the curved door features more glass for an outstanding view.

Superior visibility

360-degree visibility allows you to see all aspects of the work site. The wide rearward view provides the operator easy visibility to maneuver on all terrains. Looking forward, the low boom cross member lets you see the cutting edge of the bucket when the boom is down. Metal screens on each side provide protection and excellent side visibility.

The see-through area on the cab roof provides a clear view to the bucket, even when it is positioned at full height.

Comfortable, Clean, and Quiet Environment

- A huge glass door opens a full 90 degrees for easy entry and exit. When closed, it provides superior visibility to all corners and creates an open, uncluttered sense of space.
- A heater/defroster kit and optional air conditioning allows you to control the climate in any weather.
- Quieter interior sound levels due to full-covering and noise-absorbing trim.
- An optional sound suppression package reduces noise levels by up to three decibels for an even quieter operator environment.
- The cab sealing reduces dust infiltration.
- Front lights at the side of the cab expand your forward view, especially to the upper corners, making it easier to position loads overhead and maneuver in low-clearance areas.
- A comfortable, contoured suspension seat is standard equipment (L160 through L190).
- The ample leg room and foot room add to your operator's comfort.
- A demolition door is available in lieu of a glass door for rugged working conditions.

The full-view front windshield provides an outstanding view while the spacious cab provides a comfortable environment for the operator.

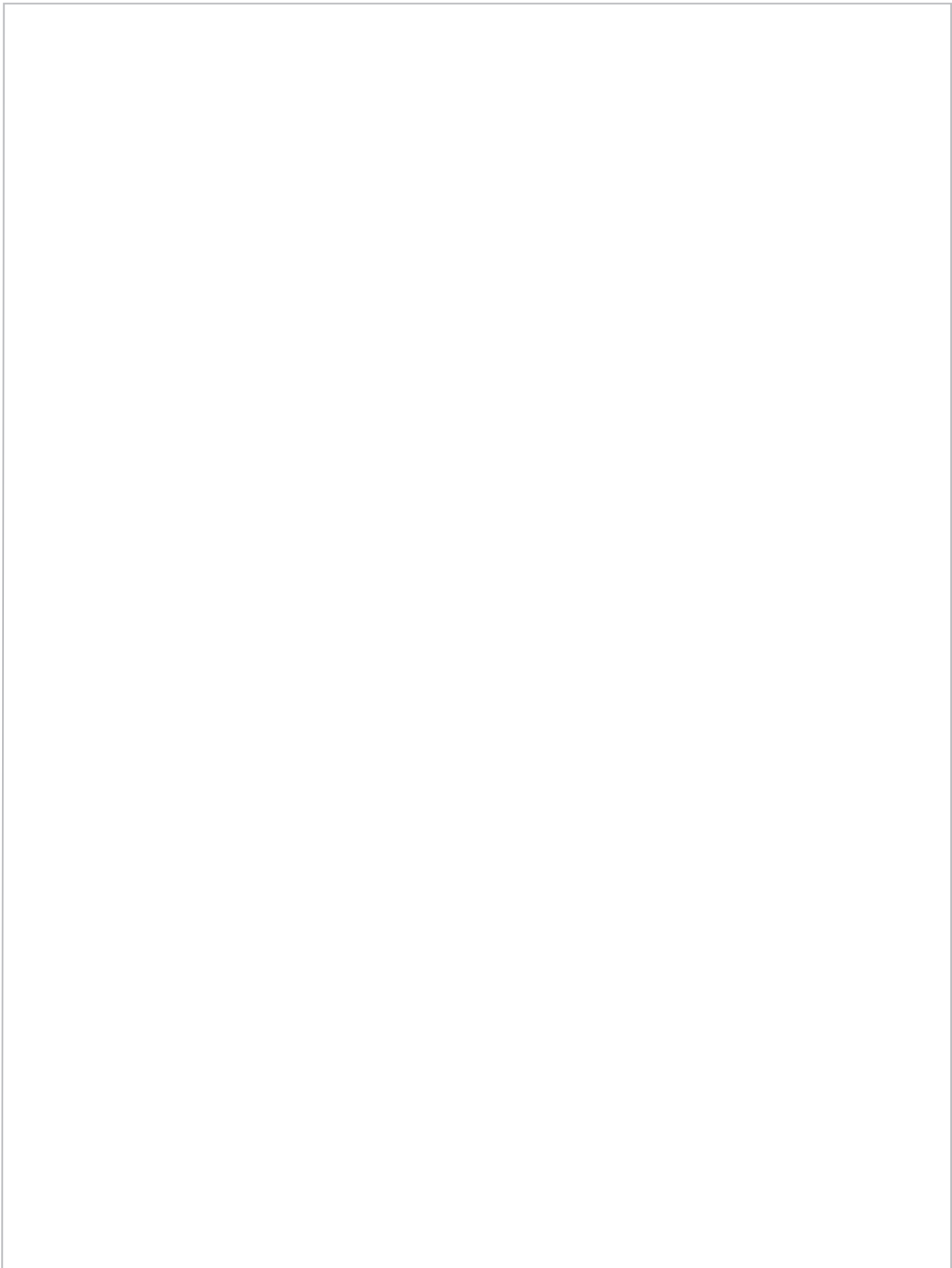

New Holland Offers Pilot Controls to Improve Productivity and Comfort.

In addition to standard mechanical controls, New Holland offers a pilot control system that makes working operations easier and more comfortable for the operator.

New Holland gives you a choice in control with mechanical controls or the pilot control system.

Optional pilot control features (L170 through L190)

- Low-effort joysticks provide instant response with minimum movement, resulting in precise control and less fatigue.
- The left joystick controls steering and machine travel (forward and reverse).
- The right joystick provides full control of the lift arm and attachment tilt. Press front or back to raise and lower the lift arm. Move the joystick right and left to dump or curl the bucket or attachment.
- The hand throttle is conveniently located to your right, allowing you to simultaneously drive with the left stick, while adjusting engine speed with your right hand.
- Long, contoured, adjustable armrests provide superior forearm support.

More options to fit your operator's preference.

Easy Access Controls

Easy to reach, eye-level backlit controls provide the operator with a quick, at-a-glance evaluation of all vital loader functions and diagnostics.

Open Floor

Ample foot room with rubber slip-resistant floor mat.

Hard Work and Demanding Conditions? BRING IT ON!

Super Boom skid steers are reliable workhorses that stand up to any challenge you face.

Optimum Stability

- Long wheelbase.
- Low center of gravity.
- Proper weight distribution.

Powerful Reliable Engines

- **FPT™** 4-cylinder, turbocharged engines are designed to have excellent performance, high torque and maximum reliability (L180, L185 and L190).
- Proven ISM engines on L150, L160, L170 and L175.
- All engines are Tier III certified and have low fuel consumption to reduce operating costs while respecting the environment.

All Weather Performance

- Standard cold weather starting aids.
- Maintenance free battery with up to 1,125 cold cranking amps.
- Reliable starter for easy starts.
- Side-by-side oil cooler and radiator provide optimal engine cooling (L180, L185 and L190).

Big Performance in Small Places

- Lower overall height.
- Compact frame.
- Easy to maneuver under low overhangs, narrow spaces, and around tight corners.

Responsive Hydraulics

- Fast cycle times.
- Optional high-flow hydraulics (on the L170 through L190) allow you to run oil-thirsty attachments hour after hour.

L175 through L190 Offer Extra Performance

- An optional dual-range transmission delivers travel speeds in excess of 11 mph to save time on and between job sites.
- In-line hydraulic pumps produce less noise and provide extra-smooth, quiet operation.

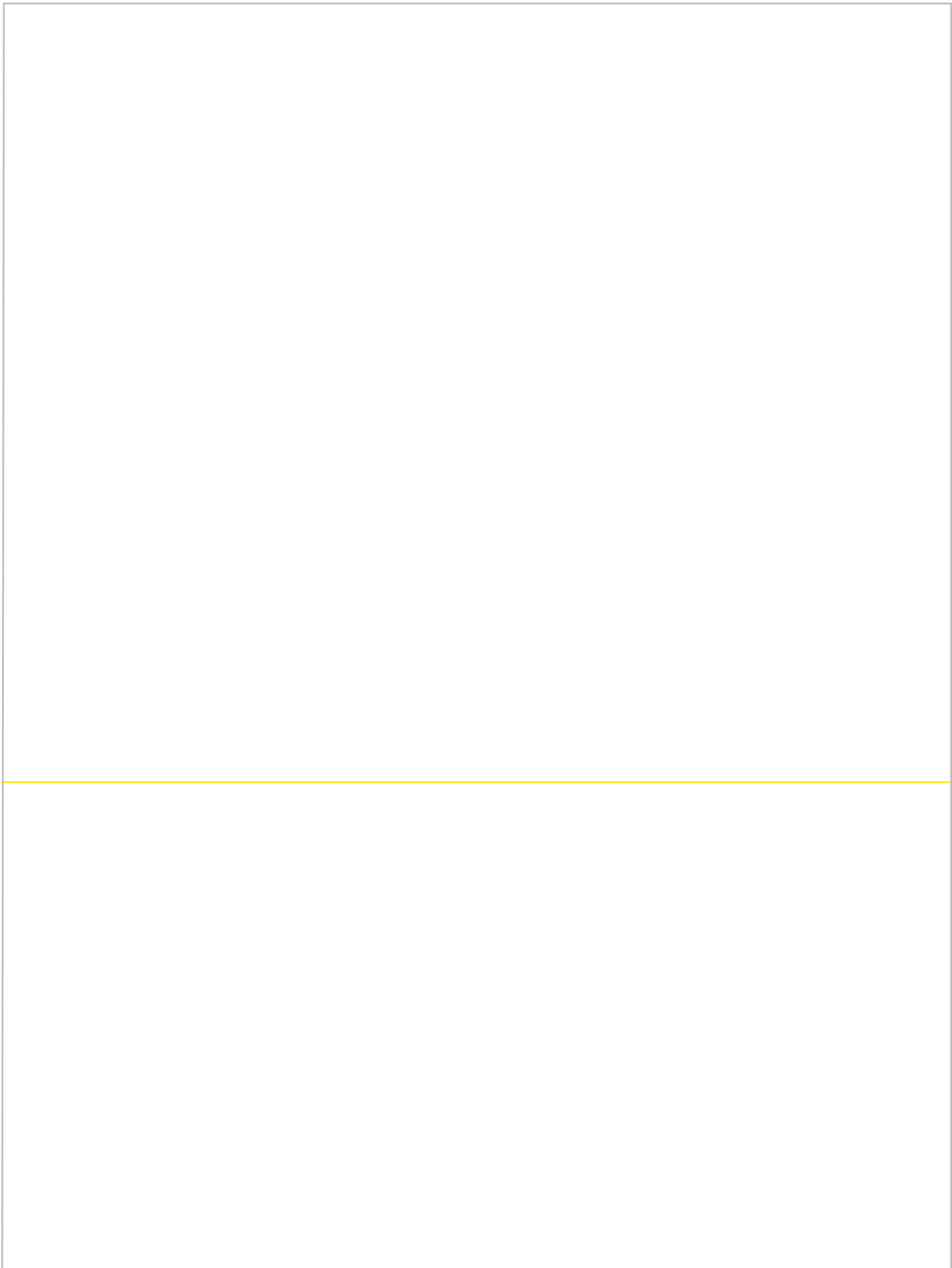

Easy Access Serviceability

No matter what the application, the Super Boom® design allows operators to be comfortable, confident and productive.

Best in Class Serviceability

- The rear door provides easy service access for periodic maintenance and daily check points (engine oil, fuel fill, hydraulic oil, coolant and radiator points may be accessed without tools).
- The service door latch is located on the outside of the door where it can be secured with one lock, providing security to the engine compartment and major components.
- The radiator can be cleaned from both sides.

Time-saving maintenance

- You can access all major service points easily, even with the boom down.
- The seat flips up without tools, to provide easy access to the hydraulic pumps and drivetrain components.
- The entire boom and cab assembly lift up and forward if more complete access is needed.

Long service intervals

- Standard lubrication interval every 50 hours.
- Engine oil and filter every 500 hours (L180, L185, L190).
- Hydraulic system filter every 500 hours; hydraulic oil every 1000 hours.
- You spend more time on the job and less time in the shop for routine maintenance.

Operator Features

- New Holland skid steers feature dual boom lock struts that when engaged keep the boom in the raised position.
- The in-the-cab boom lock-out makes it possible for the operator to engage and disengage the boom lock from inside the cab.
- Rear door louvers direct air flow up, reducing fan noise and air blast to the operator and bystanders.

The entire cab and boom assembly lift forward and up for full access to the engine or transmission.

The operator is able to engage and disengage the boom lock from inside the cab.

New Holland Skid Steer Loaders are US EPA Tier III certified for low emissions.

All major service points are easily accessed. Less maintenance time increases your bottom line.

Routine air filter maintenance is simple with an easy to reach, slide-out element.

Side-by-side radiator and oil cooler provides heat rejection for performance in extreme conditions. The rear access panel provides quick and easy access to check (L180, L185, L190) engine oil, hydraulic oil, radiator coolant and fuel fill.

Easy Attachment Changes

Whatever you need to do—dig, lift, hammer, trench, plane, mow, sweep, rake or drill—there is a New Holland attachment that will get the job done.

Universal “Pick-Up-N-Go” system

- Accepts up to 55 attachments types from the “Loadstar” Program with almost 180 variations.
- Will accept most attachments from other skid steer and attachment manufacturers.
- Allows fast and easy attachment changes – no tools required!
- The optional hydraulic mount plate (on the L160 through L190) allows you to swap out attachments without leaving your seat.

Add a Hydraulic Mount Plate (HMP) and you can easily attach or remove buckets and attachments.

L175 is shown with the snow blower attachment.

L160 is shown with the bale spear attachment.

L170 is shown with the backhoe attachment.

L190 is shown with the 4x1 bucket attachment.

L180 is shown with the pallet fork attachment.

Multi-Task Master

New Holland skid steers do a lot more than lift and load. Take a look at the wide array of attachments and you'll quickly see how the versatility of these machines can make you more productive. These are just some of the available attachments:

- 4x1 Bucket
- Auto Rake
- Backhoe
- Bale Handler
- Bale Spear
- Box Rake
- Broom
- Chipper
- Cold Planer
- Concrete Chuter
- Concrete Claw
- Dozer Blade
- Earth Auger
- Grader Rake
- Grapples
- Hydraulic Hammer
- Lift Boom
- Pallet Forks
- Post Driver
- Rock Bucket
- Rock Saw
- Root Rake
- Rotary Mower
- Silage Defacer
- Silt Fence Installer
- Snow Blade
- Snow Blower
- Snow Bucket
- Snow Push
- Soil Preparator
- Stump Grinder
- Tiller
- Tree Spade
- Trencher
- Vibratory Roller

L150 is shown with the grapple attachment.

L185 is shown with the bucket attachment.

Specifications

DIMENSIONS

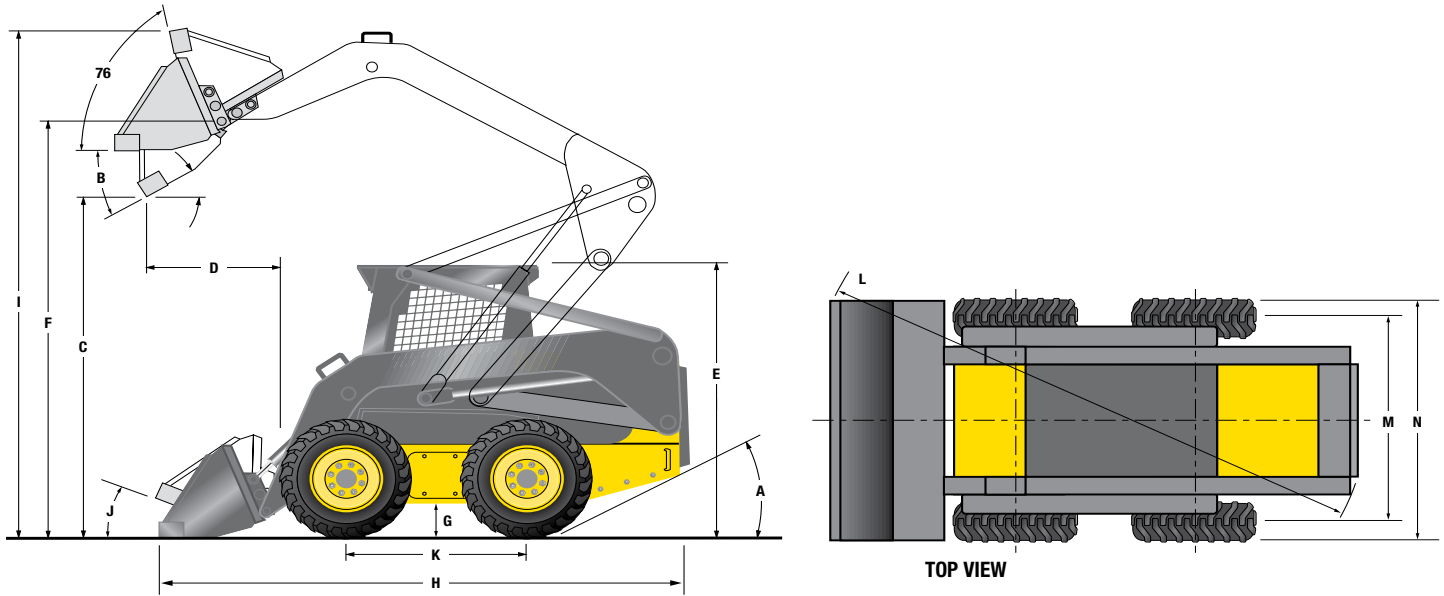

DIMENSIONS

	L150	L160	L170	L175	L180	L185	L190
A. Angle of departure	28°	28°	28°	27°	26°	26°	29°
B. Dump angle (maximum)	45°	44°	44°	43°	45°	45°	45°
C. Dump height (SAE)	92.2" (2,341 mm)	93.3" (2,371 mm)	93.3" (2,371 mm)	95.6" (2,428 mm)	94.7" (2,406 mm)	101.2" (2,569 mm)	102.8" (2,611 mm)
D. Dump reach @ maximum height (SAE)	19.8" (505 mm)	27.9" (709 mm)	27.9" (709 mm)	27.7" (703 mm)	39.5" (1,003 mm)	33.1" (840 mm)	31.7" (806 mm)
E. Height	74.1" (1,883 mm)	76.2" (1,935 mm)	76.2" (1,935 mm)	77.1" (1,975 mm)	78.7" (1,999 mm)	78.7" (1,999 mm)	80.3" (2,040 mm)
F. Height to hinge pin	115.8" (2,940 mm)	118" (2,996 mm)	118" (2,996 mm)	120.9" (3,070 mm)	126.8" (3,219 mm)	126.8" (3,219 mm)	127.6" (3,241 mm)
G. Ground clearance	8.5" (215 mm)	8.6" (219 mm)	8.6" (219 mm)	9.5" (241 mm)	8.9" (226 mm)	8.9" (226 mm)	10.6" (269 mm)
H. Length with bucket	121.3" (3,081 mm)	127.6" (3,240 mm)	127.6" (3,240 mm)	129.7" (3,293 mm)	150.3" (3,818 mm)	141.2" (3,587 mm)	148.2" (3,764 mm)
I. Operating height (maximum)	141.7" (3,599 mm)	143.8" (3,652 mm)	143.8" (3,652 mm)	147.3" (3,742 mm)	143.7" (3,651 mm)	152" (3,861 mm)	152.9" (3,884 mm)
J. Rollback angle (at carry position)	35°	35°	35°	36°	37°	37°	37°
K. Wheelbase	37.2" (945 mm)	42.5" (1,080 mm)	42.5" (1,080 mm)	42.5" (1,080 mm)	48" (1,219 mm)	48" (1,219 mm)	51" (1,296 mm)
L. Circle clearance	129.6" (3,291 mm)	138.5" (3,519 mm)	138.5" (3,519 mm)	138.6" (3,520 mm)	156" (3,963 mm)	149.4" (3,795 mm)	158" (4,013 mm)
M. Wheel tread	47.9" (1,217 mm) w/10" x 16.5" tires	53.9" (1,370 mm) w/10" x 16.5" tires	53.9" (1,370 mm) w/10" x 16.5" tires	58.6" (1,488 mm) w/12" x 16.5" tires	58.5" (1,486 mm) w/12" x 16.5" tires	58.5" (1,486 mm) w/12" x 16.5" tires	59.6" (1,514 mm) w/14" x 17.5" tires
N. Width	60" (1,524 mm)	63.9" (1,624 mm)	63.9" (1,624 mm)	70.6" (1,793 mm) w/12" x 16.5" tires	71.25" (1,810 mm)	71.25" (1,810 mm)	71.25" (1,810 mm) w/12" x 16.5" tires 76.4" (1,941 mm) w/14" x 17.5" tires

CAPACITIES

	L150	L160	L170	L175	L180	L185	L190
Chain cases (*includes gearbox)	1.5 gal (5.7 L)	3.2 gal (12.3 L)*	3.2 gal (12.3 L)*	1.5 gal (5.7 L)	1.7 gal (6.4 L)	1.7 gal (6.4 L)	1.8 gal (6.8 L)
Cooling system	2.45 gal (9.3 L)	2.7 gal (10.2 L)	2.7 gal (10.2 L)	3 gal (11.4 L)	3 gal (11.4 L)	3 gal (11.4 L)	4.5 gal (17.4 L)
Engine crankcase (w/filter)	5.8 qt (5.5 L)	6.9 qt (6.5 L)	6.9 qt (6.5 L)	8.4 qt (8.0 L)	9 qt (8.5 L)	9 qt (8.5 L)	11.6 qt (11 L)
Fuel tank	8.75 gal (33.1 L)	14.4 gal (54.5 L)	14.4 gal (54.5 L)	16.3 gal (61.7 L)	22.9 gal (86.7 L)	22.9 gal (86.7 L)	26.5 gal (100 L)
Hydraulic oil system	5 gal (18.9 L)	8.6 gal (32.6 L)	8.6 gal (32.6 L)	8.6 gal (32.6 L)	15 gal (56.8 L)	15 gal (56.8 L)	15 gal (56.8 L)

For all dimensions, machines equipped with buckets and tires (Galaxy Beefy Baby II) as noted below:

L150 – Equipped with 60" dirt and foundry bucket and 10.00 x 16.5 tires

L160 – Equipped with 60" dirt and foundry bucket and 10.00 x 16.5 tires

L170 – Equipped with 66" dirt and foundry bucket and 10.00 x 16.5 tires

L175 – Equipped with 72" dirt and foundry bucket and 12.00 x 16.5 tires

L180 – Equipped with 72" low profile bucket and 12.00 x 16.5 tires

L185 – Equipped with 72" dirt and foundry bucket and 12.00 x 16.5 tires

L190 – Equipped with 78" dirt and foundry bucket and 14.00 x 17.5 tires

Specifications

BUCKETS										
	L150	L160	L170	L175	L180	L185	L190	SAE Heaped CAPACITY	SAE Struck CAPACITY	Weight
54" (1372 mm) Dirt/Foundry	X							10.2 ft ³ (.28 m ³)	7.8 ft ³ (.21 m ³)	250 lbs (113 kg)
60" (1524 mm) Dirt/Foundry	X	X	X					11.5 ft ³ (.31 m ³)	8.7 ft ³ (.24 m ³)	270 lbs (122 kg)
66" (1676 mm) Dirt/Foundry		X	X	X				15.2 ft ³ (.41 m ³)	11.6 ft ³ (.31 m ³)	370 lbs (168 kg)
72" (1829 mm) Dirt/Foundry		X	X	X	X	X	X	16.7 ft ³ (.45 m ³)	12.7 ft ³ (.34 m ³)	390 lbs (177 kg)
78" (1981 mm) Dirt/Foundry				X	X	X	X	18.4ft ³ (.52 m ³)	13.8 ft ³ (.39 m ³)	435 lbs (197 kg)
54" (1372 mm) Low Profile	X							10.3 ft ³ (.28 m ³)	8.0 ft ³ (.22 m ³)	305 lbs (138 kg)
60" (1524 mm) Low Profile	X	X	X					11.5 ft ³ (.33 m ³)	8.9 ft ³ (.2 m ³)	330 lbs (150 kg)
60" (1524 mm) Low Profile (extended)	X	X	X					14.3 ft ³ (.40 m ³)	10.3 ft ³ (.29 m ³)	360 lbs (163 kg)
66" (1676 mm) Low Profile (extended)		X	X	X				15.5 ft ³ (.44 m ³)	11.2 ft ³ (.32 m ³)	434 lbs (197 kg)
72" (1829 mm) Low Profile (extended)		X	X	X	X	X	X	17.1 ft ³ (.48 m ³)	12.2 ft ³ (.35 m ³)	477 lbs (216 kg)
78" (1981 mm) Low Profile (extended)				X	X	X	X	18.6 ft ³ (.52 m ³)	13.2 ft ³ (.37 m ³)	502 lbs (227 kg)
84" (2134 mm) Low Profile (extended)					X	X	X	20.1 ft ³ (.57 m ³)	14.1 ft ³ (.40 m ³)	608 lbs (276 kg)
60" (1524 mm) Utility/Light Material	X	X	X					19.7 ft ³ (.56 m ³)	15.9 ft ³ (.45 m ³)	350 lbs (159 kg)
72" (1829 mm) Utility/Light Material		X	X	X	X	X	X	23.7 ft ³ (.65 m ³)	19.0 ft ³ (.52 m ³)	435 lbs (197 kg)
84" (2134 mm) Utility/Light Material		X	X	X	X	X	X	27.9 ft ³ (.79 m ³)	22.3 ft ³ (.64 m ³)	500 lbs (227 kg)
60" (1524 mm) Manure/Fertilizer	X	X	X					16.7 ft ³ (.47 m ³)	12.9 ft ³ (.37 m ³)	340 lbs (154 kg)
72" (1829 mm) Manure/Fertilizer		X	X	X	X	X	X	19.1 ft ³ (.54 m ³)	15.5 ft ³ (.44 m ³)	465 lbs (211 kg)
84" (2134 mm) Manure/Fertilizer					X	X	X	22.5 ft ³ (.64 m ³)	18.2 ft ³ (.52 m ³)	540 lbs (245 kg)

PERFORMANCE							
	L150	L160	L170	L175	L180	L185	L190
OPERATING LOAD:							
SAE	1,350 lbs (612 kg)	1,600 lbs (726 kg)	1,765 lbs (801 kg)	2,000 lbs (907 kg)	2,200 lbs (998 kg)	2,500 lbs (1,134 kg)	2,800 lbs (1,270 kg)
TIPPING LOAD:							
Without weights per SAE J-732	2,700 lbs (1,225 kg)	3,200 lbs (1,451 kg)	3,530 lbs (1,601 kg)	4,000 lbs (1,814 kg)	4,400 lbs (1,996 kg)	5,000 lbs (2,268 kg)	5,600 lbs (2,450 kg)
BREAKOUT FORCE:							
SAE Bucket breakout force	3,500 lbs (1,591 kg)	3,712 lbs (1,687 kg)	3,712 lbs (1,687 kg)	4,312 lbs (1,956 kg)	6,034 lbs (2,737 kg)	7,670 lbs (3,479 kg)	7,670 lbs (3,479 kg)
SAE Boom breakout force	2,400 lbs (1,089 kg)	2,828 lbs (1,285 kg)	2,828 lbs (1,285 kg)	3,003 lbs (1,362 kg)	4,194 lbs (1,902 kg)	4,836 lbs (2,194 kg)	6,229 lbs (2,825 kg)
OPERATING WEIGHT:							
SAE*	4,500 lbs (2,042 kg)	5,534 lbs (2,510 kg)	5,540 lbs (2,513 kg)	6,230 lbs (2,826 kg)	7,130 lbs (3,234 kg)	7,135 lbs (3,236 kg)	7,765 lbs (3,522 kg)
CYCLE TIMES:							
Raising time	3.1 sec	3.0 sec	2.7 sec	3.1 sec	2.8 sec	2.8 sec	3.3 sec
Dumping time	1.6 sec	2.0 sec	1.7 sec	2.3 sec	1.8 sec	1.8 sec	1.8 sec
Lowering time	3.5 sec	3.0 sec	2.3 sec	2.1 sec	2.5 sec	2.5 sec	3.1 sec
Retract time	1.4 sec	1.7 sec	1.5 sec	1.5 sec	1.6 sec	1.6 sec	1.6 sec
Total boom-cycle time	9.6 sec	9.7 sec	8.2 sec	9 sec	8.7 sec	8.7 sec	9.8 sec
GROUND SPEED:							
Single Speed	7.3 mph (11.8 km/h)	7.3 mph (11.8 km/h)	7.3 mph (11.8 km/h)	7.2 mph (11.6 km/h)	7.0 mph (11.2 km/h)	7.0 mph (11.2 km/h)	NA
Two Speed	NA	NA	NA	Available	Available	Available	Available
Low Range	NA	NA	NA	5.9 mph (9.5 km/h)	7.0 mph (11.2 km/h)	7.0 mph (11.2 km/h)	6.3 mph (10.1 km/h)
High Range	NA	NA	NA	10 mph (16.1 km/h)	11.3 mph (18.2 km/h)	11.3 mph (18.2 km/h)	10.3 mph (16.6 km/h)

*Base unit plus full fuel tank, 165 lbs (75 kg) operator

Specifications

POWER TRAIN							
	L150	L160	L170	L175	L180	L185	L190
Axle diameter	1.75" (44.5 mm)	2" (50.8 mm)	2" (50.8 mm)	2" (50.8 mm)	2.44" (62 mm)	2.44" (62 mm)	2.44" (62 mm)
Chain size	50/80 HD	80 HD	80 HD	80 HD	100 HD	100 HD	100 HD
Hydrostatic Transmissions:							
Hydrostatic transmission pumps variable displacement axial piston	1.31 in ³ (21.5 cc)	2.48 in ³ (40.6 cc)	2.48 in ³ (40.6 cc)	2.48 in ³ (496 cc) 1 spd 1.60 in ³ (26.2 cc) 2 spd	2.8 in ³ (46 cc) servo-controlled	2.8 in ³ (46 cc) servo-controlled	2.8 in ³ (46 cc) servo-controlled
Fixed displacement axial piston motor	2.48 in ³ (40.6 cc)	5.04 in ³ (82.6 cc)	5.04 in ³ (82.6 cc)	NA	NA	NA	NA
Radial piston motor							
Low range	NA	NA	NA	24.4 in ³ (400 cc) 1 spd 17.9 in ³ (180 cc) 2 spd	28.7 in ³ (470 cc)	28.7 in ³ (470 cc)	28.7 in ³ (470 cc)
High range	NA	NA	NA	10.1 in ³ (165 cc)	17.2 in ³ (282 cc)	17.2 in ³ (282 cc)	17.2 in ³ (282 cc)

ELECTRICAL							
	L150	L160	L170	L175	L180	L185	L190
Alternator	40 amp	40 amp	40 amp	55 amp	95 amp, solid-state rectifier and regulator 12-volt 1,125 CCA @ 0°F (-18°C) maintenance free 30 amp circuit breaker		
Battery	12-volt 650 CCA @ 0°F (-18°C) maintenance free						
System protection	30 amp circuit breaker						
INSTRUMENTS: Hour meter, voltage alarm, hydraulic oil temperature light and alarm, coolant temperature light and alarm, fuel gauge, transmission charge, pressure light and alarm, engine oil pressure light and alarm, seat belt light, engine malfunction light and alarm, transmission filter restriction light and alarm, parking brake reminder light							

ENGINE							
	L150	L160	L170	L175	L180	L185	L190
Manufacturer	ISM	ISM	ISM	ISM	FPT	FPT	FPT
Model number	N843H	N844	N844T	N844LT	F5C E9454	F5C E5454	F4G E9454
Air cleaner	Dual stage, dry element filter	Dual stage, dry element filter	Dual stage, dry element filter	Dual stage, dry element filter	Dual stage, dry element filter	Dual stage, dry element filter	Dual stage, dry element filter
Bore and stroke	3.3" x 3.54" (84 mm x 90 mm)	3.3" x 3.54" (84 mm x 90 mm)	3.3" x 3.54" (84 mm x 90 mm)	3.3" x 3.9" (84 mm x 100 mm)	3.89" x 4.09" (99 mm x 104 mm)	3.89" x 4.09" (99 mm x 104 mm)	4.1" x 5.2" (104 mm x 132 mm)
Number of cylinders	3	4	4	4	4	4	4
Displacement	91 in ³ (1.5 L)	121.7 in ³ (2.0 L)	121.7 in ³ (2.0 L)	135 in ³ (2.2 L)	195 in ³ (3.2 L)	195 in ³ (3.2 L)	274 in ³ (4.5 L)
Fuel	Diesel	Diesel	Diesel	Diesel	Diesel	Diesel	Diesel
Horsepower:							
Gross	38 hp (28.4 kW)	46 hp (34 kW)	52 hp (39 kW)	60 hp (45 kW)	74 hp (55 kW)	82 hp (61 kW)	90 hp (67 kW)
SAE net	36 hp (26.9 kW)	44 hp (33 kW)	50 hp (37 kW)	56 hp (42 kW)	69 hp (51 kW)	77 hp (57 kW)	83 hp (62 kW)
Speeds:							
Fast, no load	3450 +/- 50 rpm	3140 +/- 40 rpm	3140 +/- 40 rpm	3140 +/- 40 rpm	2675 +/- 75 rpm	2675 +/- 75 rpm	2415 +/- 60 rpm
Idle, no load	1000 +/- 50 rpm	1080 +/- 50 rpm	1080 +/- 50 rpm	1200 +/- 50 rpm	1075 +/- 50 rpm	1075 +/- 50 rpm	1075 +/- 75 rpm
Peak torque	73 lb-ft (99 N•m) @ 1900 rpm	101 lb-ft (137 N•m) @ 1700 rpm	113 lb-ft (153 N•m) @ 1700 rpm	128 lb-ft (173 N•m) @ 1700 rpm	203 lb-ft (275 N•m) @ 1400 rpm	229 lb-ft (310 N•m) @ 1400 rpm	288 lb-ft (390 N•m) @ 1300 rpm
Torque rise	15%	20%	20%	20%	28%	32%	40%

Specifications

HYDRAULICS							
	L150	L160	L170	L175	L180	L185	L190
Boom Cylinders:							
Make	New Holland double acting	New Holland double acting	New Holland double acting	New Holland double acting	New Holland double acting	New Holland double acting	New Holland double acting
Bore and stroke	2.5" x 16.13" (63.5 x 410 mm)	2.5" x 18.5" (63.5 x 470 mm)	2.5" x 18.5" (63.5 x 470 mm)	2.5" x 21.25" (63.5 x 540 mm)	2.5" x 24.06" (63.5 x 611 mm)	2.5" x 24.06" (63.5 x 611 mm)	2.75" x 24.06" (70 x 611 mm)
Rod size	1.38" (35.1 mm)	1.38" (35.1 mm)	1.38" (35.1 mm)	1.38" (35.1 mm)	1.5" (38.1 mm)	1.5" (38.1 mm)	1.75" (44.5 mm)
Bucket Cylinders:							
Make	New Holland double acting	New Holland double acting	New Holland double acting	New Holland double acting	New Holland double acting	New Holland double acting	New Holland double acting
Bore and stroke	2.5" x 18.125" (64 x 460 mm)	2.25" x 17.88" (57.2 x 454.2 mm)	2.25" x 17.88" (57.2 x 454.2 mm)	2.25" x 17.88" (57.2 x 454.2 mm)	2.5" x 17.6" (64 x 447 mm)	2.5" x 17.6" (64 x 447 mm)	2.5" x 17.6" (64 x 447 mm)
Rod size	1.125" (28.6 mm)	1.25" (31.8 mm)	1.25" (31.8 mm)	1.25" (31.8 mm)	1.25" (31.8 mm)	1.25" (31.8 mm)	1.25" (31.8 mm)
Control valve	3-spool open center	3-spool open center	3-spool open center	3-spool open center	3-spool open center	3-spool open center	3-spool open center
Filtration	5-micron, spin-on filter	5-micron, spin-on filter	5-micron, spin-on filter	5-micron, spin-on filter	6-micron, spin-on filter	6-micron, spin-on filter	6-micron, spin-on filter
Hydraulic pump	Gear type 11.6 gpm	Gear type 15.1 gpm	Gear type 17.2 gpm	Gear type 17.2 gpm	Gear type 21.0 gpm	Gear type 21.0 gpm	Gear type 21.9 gpm
High flow hydraulics (if equipped)	NA	NA	25.5 gpm	25.5 gpm	35.8 gpm	35.8 gpm	37.3 gpm
Oil reservoir	1.5 gal (5.7 L)	3.9 gal (14.8 L)	3.9 gal (14.8 L)	3.9 gal (14.8 L)	5 gal (18.9 L)	5 gal (18.9 L)	5 gal (18.9 L)
Relief pressure setting	2,500 psi (172 bar)	2,500 psi (172 bar)	2,500 psi (172 bar)	2500 psi (172 bar)	3,050 psi (210 bar)	3,050 psi (210 bar)	3,050 psi (210 bar)

L150 L160 L170 L175 Base & Optional Equipment

BASE EQUIPMENT	
ENGINE	Transmission filter restriction light and alarm
Block heater	
Dual stage, dry element air filter	Parking brake reminder light
Indirect injection diesel	
Timed glow plug	
HYDRAULICS	LIGHTING
New Holland double-acting boom cylinders	Work lights: two front halogen and two front incandescent, one rear halogen and two rear incandescent.
New Holland double-acting bucket cylinders	
Spin-on filter, 4 micron	
Three-spool, open-center control valve	
TRANSMISSION	SERVICE
Variable displacement axial piston pumps, axial piston motors	Boom and cab tilting feature
Variable displacement axial piston pumps, radial piston motors (L175)	50-hour lube interval
	Lift-up seat pan (no tools required)
	Low-mounted fuel fill
	Rear engine door/top engine cover
	Removable side engine panels (no tools required)
ELECTRICAL	SAFETY
12-volt system	Back-up alarm
Alternator, 40 amp	Horn
Alternator, 55 amp (L175)	Manual, in-cab boom lockouts
Single battery, 625 CCA	Seat belt interlock
Fuse circuit protectors	Spring Applied Hydraulic Released (SAHR) brake
Hour meter	
Voltage alarm	VANDAL PROTECTION
Hydraulic oil temperature light and alarm	Enclosed fuel cap
Coolant temperature light and alarm	Enclosed hydraulic fill
Fuel gauge	Lockable rear door, engine cover and side panels
Transmission charge pressure light and alarm	
Engine oil pressure light and alarm	ACCESSORIES
Seat belt light	12-volt accessory power plug
Rotating Beacon Pre-Wiring	Armrests
Air cleaner restriction light and alarm	Boom hydraulics with flat-face couplers
	Cab headliner
	Engine cold start
	Remote Jump Start (L175)
	Suspension seat (L160, L170 & L175)

OPTIONAL EQUIPMENT	
LIGHTING	High flow hydraulics (L170, L175)
Four-way flashers/warning lights	Hydraulic mount plate (L160, L170 and L175)
Turn signals	Pilot Controls (L170 and L175)
TIRES	Precleaner/aspirator (L160, L170)
See your dealer for approved tire options	Rearview mirror
ACCESSORIES	Shoulder belt
Air conditioning (L175)	SMV signs
Bucket spill guard (low-profile buckets only)	Three-inch seat belt
Bucket tooth kit (low-profile, dirt & foundry only)	Top window
Cab jack kit	Two-speed transmission (L175)
Cab enclosure	Warning beacon
Cab side window kit	Weight kit
Catalytic muffler (L160, L170)	
Advanced instrument panel	<i>See your local New Holland dealer for approved attachments</i>
Demolition door	
Fire extinguisher bracket kit	
Floor cover plates	
Hand controls	
Heater/defroster	

New Holland Skid Steer Loaders are US EPA Tier III certified for low emissions.

L180 L185 L190 Base & Optional Equipment

BASE EQUIPMENT	
<p>ENGINE Dual stage, dry element air filter Grid Heater Indirect injection diesel</p>	<p>LIGHTING Work lights: two front halogen and two front incandescent, one rear halogen and two rear incandescent.</p>
<p>HYDRAULICS New Holland double-acting boom cylinders New Holland double-acting bucket cylinders Spin-on filter, 6 micron Three-spool, open-center control valve</p>	<p>SERVICE Boom and cab tilting feature 50-hour lube interval Lift-up seat pan (no tools required) Low-mounted fuel fill Rear engine door/top engine cover Removable side engine panels (no tools required)</p>
<p>TRANSMISSION Variable displacement axial piston pumps, radial piston motors</p>	<p>SAFETY Back-up alarm Horn Manual, in-cab boom lockouts Seat belt interlock Spring Applied Hydraulic Released (SAHR) brake</p>
<p>ELECTRICAL 12-volt system Alternator, 95 amp Single battery, 1125 CCA 30-amp circuit breaker Hour meter Voltage alarm Hydraulic oil temperature light and alarm Coolant temperature light and alarm Fuel gauge Transmission charge pressure light and alarm Engine oil pressure light and alarm Seat belt light Air cleaner restriction light and alarm Rotating Beacon Pre-Wiring Transmission filter restriction light and alarm Parking brake reminder light</p>	<p>VANDAL PROTECTION Enclosed fuel cap Enclosed hydraulic fill Lockable rear door, engine cover and side panels</p>
	<p>ACCESSORIES 12-volt accessory power plug Advanced instrument panel (L185 & L190) Armrests Boom hydraulics with flat-face couplers Cab headliner Remote Jump Start Suspension seat</p>

OPTIONAL EQUIPMENT	
<p>LIGHTING Four-way flashers/warning lights Turn signals</p>	<p>High flow hydraulics Hydraulic mount plate Pilot Controls Precleaner/aspirator Rearview mirror Shoulder belt</p>
<p>TIRES See your dealer for approved tire options</p>	<p>SMV signs Three-inch seat belt Top window Two-speed Warning beacon Weight kit</p>
<p>ACCESSORIES Air conditioning Block heater Bucket spill guard (low profile buckets only) Bucket tooth kit (low profile, dirt & foundry only) Cab jack kit Cab enclosure Cab side window kit Advanced instrument panel (L180) Demolition door Fire extinguisher bracket kit Floor cover plates Hand controls Heater/defroster</p>	<p><i>See your local New Holland dealer for approved attachments</i></p>

Feel the passion we've built into the new New Holland Super Boom Skid Steer Loaders. If you demand productivity, performance and control, see your nearest New Holland dealer today, or use our dealer locator at www.NewHolland.com to find the dealer nearest you.

SUPER BOOM SKID STEER LOADERS

L150

Horsepower
Gross 38 hp (28.4 kW)

Operating weight
4,500 lbs (2,042 kg)

Rated operating capacity
1,350 lbs (612 kg)

L160

Horsepower
Gross 46 hp (34.3 kW)

Operating weight
5,534 lbs (2510 kg)

Rated operating capacity
1,600 lbs (726 kg)

L170

Horsepower
Gross 52 hp (39.3 kW)

Operating weight
5,540 lbs (2513 kg)

Rated operating capacity
1,765 lbs (801 kg)

L175

Horsepower
Gross 60 hp (45 kW)

Operating weight
6,230 lbs (2826 kg)

Rated operating capacity
2,000 lbs (907 kg)

L180

Horsepower
Gross 74 hp (55 kW)

Operating weight
7130 lbs (3234 kg)

Rated operating capacity
2,200 lbs (998 kg)

L185

Horsepower
Gross 82 hp (61 kW)

Operating weight
7135 lbs (3236 kg)

Rated operating capacity
2,500 lbs (1134 kg)

L190

Horsepower
Gross 90 hp (67 kW)

Operating weight
7765 lbs (3522 kg)

Rated operating capacity
2,800 lbs (1270 kg)

World Class Products Demand World Class Dealers

The purchase of a New Holland Construction machine is just the beginning of our relationship together. Consider your experienced New Holland Construction Equipment dealer as your local partner in productivity. Assistance in selecting the right model for your operation and developing an affordable leasing or financing plan through CNH Capital are just a few advantages your local dealer can provide.

Your New Holland Construction dealer's full service capabilities bring you responsive support with genuine New Holland parts and all makes coverage. More importantly, we are there wherever and whenever you need us with our fully equipped service vehicles. From customized maintenance programs to professional operator and technical training, our factory-trained service and parts experts are there to assist you with any of your equipment support needs.

Your business deserves nothing less than world class product, supported by a world class business partner. That's your New Holland Construction Equipment dealer—your partner in productivity.

New Holland Construction Equipment is backed with a **1-Year/Unlimited Hour Standard Warranty**.

Use our dealer locator at www.newholland.com to find the dealer nearest you.

New Holland Construction
245 E. North Avenue
Carol Stream, IL 60188-2021
866-726-3396 Toll Free
630-260-4000
630-260-4369 Fax



www.newholland.com

Design, materials and/or specifications are subject to change without notice and without liability therefor. Specifications are applicable to units sold in Canada, the United States, its territories and possessions, and may vary outside these areas.

© 2008 CNH America LLC. All rights reserved. New Holland is a trademark of CNH America LLC. Any trademarks referred to herein, in association with goods and/or services of companies other than CNH America LLC, are the property of those respective companies.



Safety begins with a thorough understanding of the equipment. Always make sure you and your operators read the Operator's Manual before using the equipment. Pay close attention to all safety and operating decals and never operate machinery without all shields, protective devices and structures in place.

STOCK #NHC10090801 • 100810 • MG • PRINTED IN U.S.A.