



NEW HOLLAND

L213 L215 L218 L220 L223 L225 L230
200 SERIES SKID STEER LOADERS



200 SERIES

Preliminary Brochure



BUILT AROUND YOU

Courtesy of Machine.Market

Super Boom® Skid Steer Specifications

DIMENSIONS

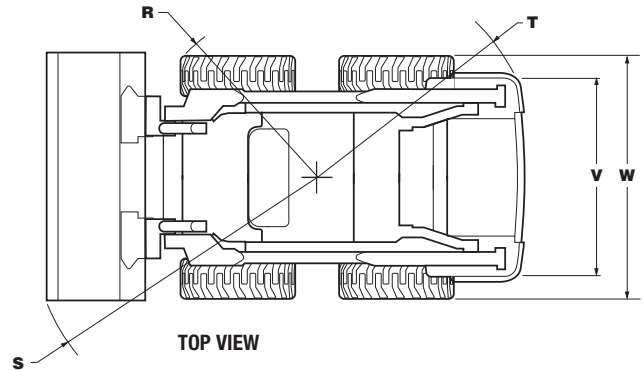
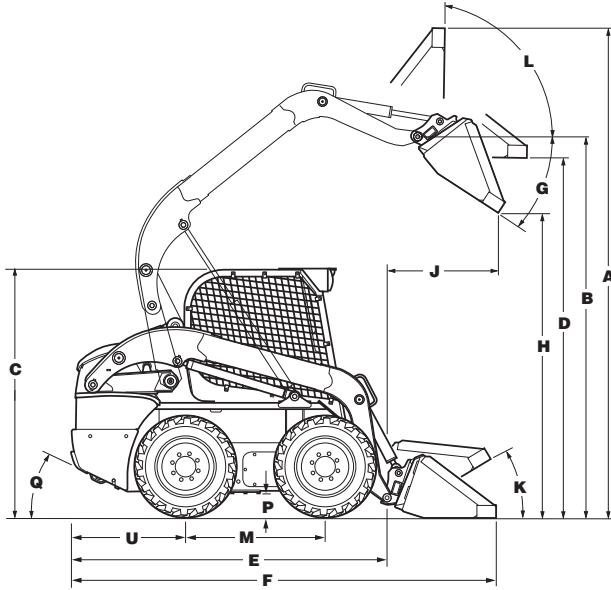

DIMENSIONS	L218	L220	L223	L225	L230
Overall operating height					
A. with foundry/excavating bucket short lip, in (mm)	150.4 (3820)	151.4 (3845)	159.7 (4056)	159.7 (4056)	161.3 (4096)
A. with low profile/standard lip bucket, in (mm)	154.6 (3927)	155.6 (3952)	163.7 (4159)	163.7 (4159)	165.3 (4199)
A. with low profile extended/long lip bucket, in (mm)	159.6 (4055)	160.6 (4080)	168.8 (4287)	168.8 (4287)	170.4 (4327)
Height to					
B. Bucket hinge pin, in (mm)	120 (3048)	121 (3073)	129.5 (3290)	129.5 (3290)	131.1 (3330)
C. Top of ROPS, in (mm)	77.7 (1974)	78.7 (1998)	78.8 (2002)	78.8 (2002)	80.4 (2042)
D. Bottom of level bucket, fully raised, in (mm)	113.3 (2877)	114.3 (2902)	122.6 (3115)	122.6 (3115)	124.2 (3155)
Overall length					
E. without attachment with coupler, in (mm)	105.7 (2685)	105.7 (2685)	117.8 (2993)	117.6 (2986)	117.6 (2986)
F. with foundry excavation bucket on ground, in (mm)	131.9 (3352)	131.4 (3338)	142.9 (3631)	142.7 (3624)	142.7 (3624)
F. with low profile bucket, in (mm)	136.1 (3456)	135.4 (3440)	146.7 (3727)	146.7 (3727)	146.7 (3727)
F. with low profile extended bucket, in (mm)	141.1 (3585)	140.5 (3569)	152.1 (3863)	151.8 (3856)	151.8 (3856)
Dump					
G. Dump angle, degrees	52	52	55	55	55
H. Dump height					
with foundry/excavating bucket short lip, in (mm)	93.6 (2377)	94.5 (2402)	102.9 (2615)	102.9 (2615)	104.5 (2655)
with low profile/standard lip bucket, in (mm)	88.6 (2251)	89.6 (2276)	100.6 (2556)	100.6 (2556)	102.2 (2596)
J. Dump reach (max height), in (mm)	30.8 (783)	29.8 (758)	32.3 (820)	32.3 (820)	30.7 (780)
Maximum attachment rollback					
K. Bucket on ground, degrees	35	34	34	34	33
L. Bucket at full height, degrees	88	88	85	85	85
Wheelbase and Clearance					
M. Wheelbase, in (mm)	44.4 (1128)	44.4 (1128)	52 (1322)	52 (1322)	52 (1322)
P. Ground clearance (bottom of belly pan), in (mm)	7 (178)	8 (203)	8 (203)	8 (203)	9.5 (243)
Q. Angle of departure, degrees	23	25	24	24	27
Clearance circle					
R. without bucket, in (mm)	50.7 (1289)	50.7 (1289)	56.2 (1428)	56.2 (1428)	56.2 (1428)
S. with foundry bucket in carry position, in (mm)	79.6 (2021)	80.9 (2055)	80.3 (2039)	80.3 (2039)	84.8 (2155)
w/66" bucket		w/72" bucket	w/72" bucket	w/72" bucket	w/78" bucket
S. with low profile bucket on ground, in (mm)	83.9 (2132)	84.6 (2150)	87 (2210)	87 (2210)	88.4 (2246)
w/66" bucket		w/72" bucket	w/72" bucket	w/72" bucket	w/78" bucket
S. with extended low profile on ground, in (mm)	88.6 (2250)	89.3 (2268)	91.5 (2323)	91.5 (2323)	92.6 (2352)
w/66" bucket		w/72" bucket	w/72" bucket	w/72" bucket	w/78" bucket
T. Clearance circle rear, in (mm)	63.2 (1606)	62.9 (1599)	70.7 (1796)	70.4 (1789)	70.4 (1789)
U. Rear axle to bumper, in (mm)	36.4 (924)	36.4 (924)	40.7 (1034)	40.7 (1034)	40.7 (1034)
V. Tread width, in (mm)	53.9 (1371)	56.9 (1448)	56.9 (1448)	57.7 (1465)	57.7 (1465)
w/10" x 16.5" tires		w/12" x 16.5" tires	w/12" x 16.5" tires	w/12" x 16.5" tires	w/12" x 16.5" tires
W. Overall width, in (mm)	66.1 (1678)	69.1 (1755)	69.2 (1758)	69.2 (1758)	76 (1930)

Super Boom® Skid Steer Specifications

ENGINE	L218	L220	L223	L225	L230
Manufacturer/model	ISM / N844LT	ISM / N844LT	FPT / F5C E9454	FPT / F5C E9454	FPT / F5C E9454
Type	Diesel 4-stroke, Turbo, I.D.I.	Diesel 4-stroke, Turbo, I.D.I.	Diesel 4-stroke, Turbo, D.I.	Diesel 4-stroke, Turbo, D.I.	Diesel 4-stroke, Turbo, D.I.
Cylinder	4	4	4	4	4
Bore/stroke, in (mm)	3.31 x 3.94 (84 x 100)	3.31 x 3.94 (84 x 100)	3.9 x 4.1 (99 x 104)	3.9 x 4.1 (99 x 104)	3.9 x 4.1 (99 x 104)
Displacement, in³ (L)	135 (2.2)	135 (2.2)	195 (3.2)	195 (3.2)	195 (3.2)
Fuel injection	Indirect	Indirect	Direct	Direct	Direct
Fuel	#2 diesel	#2 diesel	#2 diesel	#2 diesel	#2 diesel
Fuel filter	In-line w/water separator	In-line w/water separator	In-line w/water separator	In-line w/water separator	In-line w/water separator
Air intake	Turbocharged w/ internal EGR	Turbocharged w/ internal EGR	Turbocharged w/ external EGR	Turbocharged w/ external EGR	Turbocharged w/ external EGR
Cooling	Liquid	Liquid	Liquid	Liquid	Liquid
Engine speeds					
High idle - no load, rpm	3080 +/- 50	3080 +/- 50	2675 +/- 75	2675 +/- 75	2675 +/- 75
Rated - full load, rpm	2900	2900	2500	2500	2500
Low idle, rpm	1200 +/-50	1200 +/-50	1075 +/- 75	1075 +/- 75	1075 +/- 75
Horsepower per SAE J1349					
Gross hp (kW)	60 (45) @ 2900 rpm	60 (45) @ 2900 rpm	74 (55) @ 2500 rpm	82 (61) @ 2500 rpm	90 (67) @ 2500 rpm
Net hp (kW)	57 (42) @ 2900 rpm	57 (42) @ 2900 rpm	68 (51) @ 2500 rpm	76 (57) @ 2500 rpm	84 (63) @ 2500 rpm
Peak torque, lb-ft (N•m)	126 (171) @ 1800 rpm	126 (171) @ 1800 rpm	203 (275) @ 1400 rpm	225 (305) @ 1400 rpm	251 (340) @ 1400 rpm

POWER TRAIN	L218	L220	L223	L225	L230
Drive pump mechanical					
Pump to engine ratio	1:1	1:1	1:1	1:1	1:1
Displacement, in³ (cc)	2.14 (35)	2.14 (35)	46 (2.81)	46 (2.81)	46 (2.81)
Flow at rated engine rpm @100% eff., gpm (Lpm)	26.9 (102)	26.9 (102)	30.4 (115)	30.4 (115)	30.4 (115)
Charge pressure, psi (bar)	363 (24.5)	363 (24.5)	363 (24.5)	363 (24.5)	363 (24.5)
System relief, psi (bar)	5000 (345)	5000 (345)	5000 (345)	5000 (345)	5000 (345)
Control	Direct mechanical	Direct mechanical	Mechanical servo	Mechanical servo	Mechanical servo
Drive pump electro hydraulic					
Pump to engine ratio	1:1	1:1	1:1	1:1	1:1
Displacement, in³ (cc)	2.14 (35)	2.14 (35)	2.81 (46)	2.81 (46)	2.81 (46)
Flow, gpm (Lpm)	26.9 (102)	26.9 (102)	30.4 (115)	30.4 (115)	30.4 (115)
Charge pressure, psi (bar)	363 (25)	363 (25)	363 (25)	363 (25)	363 (25)
System relief, psi (bar)	5220 (360)	5220 (360)	5220 (360)	5220 (360)	5220 (360)
Control	Electro hydraulic	Electro hydraulic	Electro hydraulic	Electro hydraulic	Electro hydraulic
Drive motors					
Max displacement, in³ (cc)	19.83 (325)	19.83 (325)	28.68 (470)	28.68 (470)	28.68 (470)
Displacement opt high speed, in³ (cc)	12.2 (200)	12.2 (200)	17.21 (282)	17.21 (282)	17.21 (282)
Speed @ high idle engine rpm	313	313	244	244	244
Speed @ optional high speed, rpm	509	509	408	408	408
Torque @ max displ. and relief pressure, lb-ft (N•m)	1316 (1784)	1316 (1784)	1987 (2694)	1987 (2694)	1987 (2694)
Travel speed					
Low range, mph (km/h)	7.4 (11.9)	7.5 (12.1)	7.2 (11.6)	7.2 (11.6)	7.5 (12.1)
High range (optional), mph (km/h)	11.5 (18.5)	11.8 (19)	11.9 (19.2)	11.9 (19.2)	12.2 (19.6)
Final drive	Single-reduction chain drive				
Drive chain					
Size	ASA #80	ASA #80	ASA #100	ASA #100	ASA #100
Axles					
Diameter, in (mm)	2 (50.8)	2 (50.8)	2.44 (61.94)	2.44 (61.94)	2.44 (61.94)
Length, in (mm)	15.1 (384)	15.1 (384)	15.7 (398.7)	15.7 (398.7)	15.7 (398.7)
Parking brake					
Type	Spring applied, hydraulic release disc				
Engagement	Depress on/off brake button on instrument panel, disconnect lapbelt, get off seat, or stop engine				

Super Boom® Skid Steer Specifications

HYDRAULIC SYSTEM	L218	L220	L223	L225	L230
Pumps					
Type	Gear	Gear	Gear	Gear	Gear
Displacement standard aux., in ³ (cc)	1.52 (24.9)	1.52 (24.9)	2.08 (34.1)	2.08 (34.1)	2.08 (34.1)
Displacement high flow aux., in ³ (cc)	.76 (12.5)	.76 (12.5)	1.12 (18.3)	1.12 (18.3)	1.12 (18.3)
Pump flow, gpm (Lpm)	19 (72)	19 (72)	22.5 (85)	22.5 (85)	22.5 (85)
Optional high flow, gpm (Lpm)	28.5 (108)	28.5 (108)	34.6 (131)	34.6 (131)	34.6 (131)
Loader control valve					
Type	3 spool / open center / series				
Relief pressure, psi (bar)	3000 (207)	3000 (207)	3000 (207)	3000 (207)	3000 (207)
Hydraulic filter	6 micron / spin on	6 micron / spin on	6 micron / spin on	6 micron / spin on	6 micron / spin on

CYLINDERS	L218	L220	L223	L225	L230
Lift cylinder					
Bore diameter, in (mm)	2.25 (57)	2.25 (57)	2.5 (64)	2.5 (64)	2.5 (64)
Rod diameter, in (mm)	1.375 (35)	1.375 (35)	1.75 (45)	1.75 (45)	1.75 (45)
Stroke in, in (mm)	26.8 (681)	26.8 (681)	33.5 (852)	33.5 (852)	33.5 (852)
Closed length, in (mm)	38.7 (982)	38.7 (982)	46.9 (1192)	46.9 (1192)	46.9 (1192)
Bucket cylinders					
Bore diameter, in (mm)	2.5 (64)	2.75 (70)	3.0 (76)	3.0 (76)	3.0 (76)
Rod diameter, in (mm)	1.375 (35)	1.375 (35)	1.5 (38)	1.5 (38)	1.5 (38)
Stroke, in (mm)	16.1 (410)	16.1 (410)	16.1 (410)	16.1 (410)	16.1 (410)
Closed length, in (mm)	24 (610)	24 (610)	24 (610)	24 (610)	24 (610)

WEIGHTS	L218	L220	L223	L225	L230
Operating weight, lbs (kg)	5860 (2660)	6400 (2900)	7380 (3350)	7900 (3580)	8300 (3765)
Shipping weight, with bucket, lbs (kg)	5560 (2520)	6100 (2765)	7050 (3200)	7565 (3430)	7965 (3610)

SERVICE CAPACITIES	L218	L220	L223	L225	L230
Fuel tank, gal (L)	20 (75.5)	20 (75.5)	25.5 (96.5)	25.5 (96.5)	25.5 (96.5)
Engine oil with filter, qt (L)	8 (8.5)	8 (8.5)	10.5 (10)	10.5 (10)	10.5 (10)
Hydraulic system					
Reservoir, gal (L)	4.3 (16.2)	4.3 (16.2)	6 (22.75)	6 (22.75)	6 (22.75)
Chain tanks (per side), qt (L)	7.1 (6.7)	7.1 (6.7)	7.8 (7.4)	7.8 (7.4)	7.8 (7.4)

PERFORMANCE SPECS	L218	L220	L223	L225	L230
Rated operating load					
50% tip, lbs (kg)	1800 (818)	2000 (905)	2250 (1020)	2500 (1135)	3000 (1360)
Tipping load, lbs (kg)	3600 (1632)	4000 (1814)	4500 (2041)	5000 (2268)	6000 (2722)
Breakout forces					
Lift cylinder, lbs (kN)	2740 (12.2)	2615 (11.6)	5090 (22.6)	5090 (22.6)	4940 (22)
Bucket cylinder, lbs (kN)	5435 (24.2)	7145 (31.8)	8585 (38.2)	8585 (38.2)	8585 (38.2)
Cycle times					
Raise, sec	3.0	3.0	3.9	3.9	3.9
Lower, sec	2.4	2.4	2.5	2.5	2.5
Dump, sec	2.2	2.6	2.7	2.7	2.7
Roll back, sec	1.5	1.8	2.0	2.0	2.0

For all Dimensions and Performance Metrics, unless otherwise specified:

L218 – Equipped with 175 lb operator, 66" Dirt & Foundry Bucket with 10 x 16.5 tires
 L220 – Equipped with 175 lb operator, 66" Dirt & Foundry Bucket with 12 x 16.5 tires
 L223 – Equipped with 175 lb operator, 72" Dirt & Foundry Bucket with 12 x 16.5 tires

L225 – Equipped with 175 lb operator, 72" Dirt & Foundry Bucket with 12 x 16.5 tires
 L230 – Equipped with 175 lb operator, 78" Dirt & Foundry Bucket with 14 x 17.5 tires

Skid Steer Specifications (Radial Lift)

DIMENSIONS

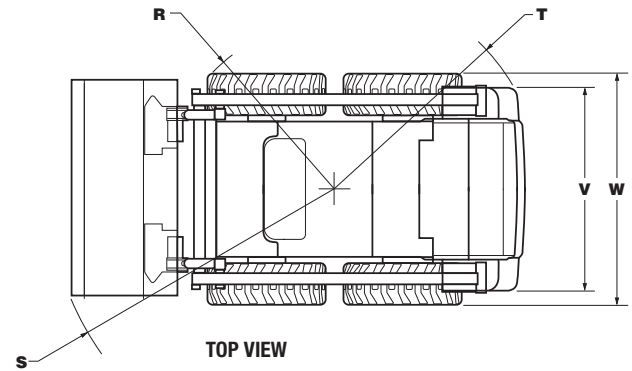
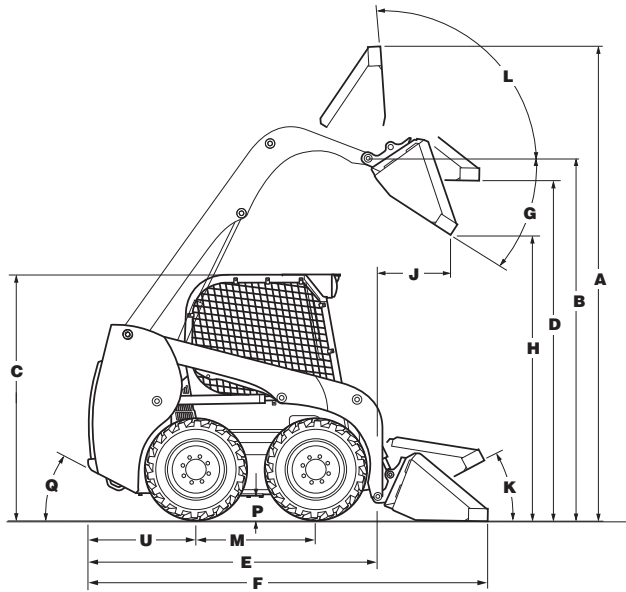

DIMENSIONS	L213	L215
Overall operating height		
A. with foundry/excavating bucket short lip, in (mm)	141.4 (3591)	141.4 (3591)
A. with low profile/standard lip bucket, in (mm)	146.9 (3732)	146.9 (3732)
A. with low profile extended/long lip bucket, in (mm)	152 (3859)	152 (3859)
Height to		
B. Bucket hinge pin, in (mm)	112 (2845)	112 (2845)
C. Top of ROPS, in (mm)	75.5 (1919)	75.5 (1919)
D. Bottom of level bucket, fully raised, in (mm)	105.6 (2682)	105.6 (2682)
Overall length		
E. without attachment with coupler, in (mm)	95.9 (2435)	95.9 (2435)
F. with foundry excavation bucket on ground, in (mm)	119.2 (3028)	119.2 (3028)
F. with low profile bucket, in (mm)	125 (3175)	125 (3175)
F. with low profile extended bucket, in (mm)	129.8 (3297)	129.8 (3297)
Dump		
G. Dump angle, degrees	40	40
H. Dump height		
with foundry/excavating bucket short lip, in (mm)	88.4 (2246)	88.4 (2246)
with low profile/standard lip bucket, in (mm)	84.8 (2154)	84.8 (2154)
J. Dump reach (max height), in (mm)	18.5 (469)	18.5 (469)
Maximum attachment rollback		
K. Bucket on ground, degrees	26	26
L. Bucket at full height, degrees	95	95
Wheelbase and Clearance		
M. Wheelbase, in (mm)	37 (941)	37 (941)
P. Ground clearance (bottom of belly pan), in (mm)	7 (178)	7 (178)
Q. Angle of departure, degrees	22	22
Clearance circle		
R. without bucket, in (mm)	48.7 (1237)	48.7 (1237)
S. with 60" inch foundry bucket in carry position, in (mm)	75.6 (1920)	75.6 (1920)
S. with 60" inch low profile bucket on ground, in (mm)	78.5 (1994)	78.5 (1994)
S. with 60" inch extended low profile on ground, in (mm)	83.1 (2112)	83.1 (2112)
T. Clearance circle rear, in (mm)	56.4 (1433)	56.4 (1433)
U. Rear axle to bumper, in (mm)	33.8 (858)	33.8 (858)
V. Tread width, in (mm)	49.2 (1248) w/10" x 16.5" tires	49.2 (1248) w/10" x 16.5" tires
W. Overall width, in (mm)	59.8 (1518)	59.8 (1518)

Skid Steer Specifications (Radial Lift)

ENGINE	L213	L215
Manufacturer/model	ISM / N844	ISM / N844T
Type	Diesel 4-stroke, I.D.I.	Diesel 4-stroke, T, I.D.I.
Cylinder	4	4
Bore/stroke, in (mm)	3.31 x 3.54 (84 x 90)	3.31 x 3.54 (84 x 90)
Displacement, in ³ (L)	121.7 (2.0)	121.7 (2.0)
Fuel injection	Indirect	Indirect
Fuel	#2 diesel	#2 diesel
Fuel filter	In-line strainer	In-line strainer
Air intake	Naturally aspirated w/ internal EGR	Turbocharged w/ internal EGR
Cooling	Liquid	Liquid
Engine speeds		
High idle - no load, rpm	3140 +/- 50	3140 +/- 50
Rated - full load, rpm	2900	2900
Low idle, rpm	1080+/-50	1080+/-50
Horsepower per SAE J1349		
Gross hp (kW)	46 (34.3) @ 2900 rpm	52 (38.8) @ 2900 rpm
Net hp (kW)	43 (31.8) @ 2900 rpm	49 (36.3) @ 2900 rpm
Peak torque, lb-ft (N•m)	96.3 (130.5) @ 1750 rpm	109 (148) @ 1750 rpm

POWER TRAIN	L213	L215
Drive pump mechanical		
Pump to engine ratio	1:1	1:1
Displacement, in ³ (cc)	2.14 (35)	2.14 (35)
Flow, gpm (Lpm)	26.9 (102)	26.9 (102)
Charge pressure, psi (bar)	363 (25)	363 (25)
System relief, psi (bar)	5000 (345)	5000 (345)
Control	Direct mechanical	Direct mechanical
Drive pump electro hydraulic		
Pump to engine ratio	1:1	1:1
Displacement, in ³ (cc)	2.14 (35)	2.14 (35)
Flow, gpm (Lpm)	26.9 (102)	26.9 (102)
Charge pressure, psi (bar)	363 (25)	363 (25)
System relief, psi (bar)	5220 (360)	5220 (360)
Control	Electro hydraulic	Electro hydraulic
Drive motors		
Max displacement, in ³ (cc)	19.83 (325)	19.83 (325)
Displacement opt high speed, in ³ (cc)	NA	NA
Speed @ high idle engine rpm	313	313
Speed @ optional high speed, rpm	NA	NA
Torque @ max displ. and relief pressure, lb-ft (N•m)	1316 (1784)	1316 (1784)
Travel speed		
Low range, mph (km/h)	6.7 (10.8)	6.7 (10.8)
High range (optional), mph (km/h)	NA	NA
Final drive	Single-reduction chain drive	Single-reduction chain drive
Drive chain		
Size	ASA #80	ASA #80
Axles		
Diameter, in (mm)	2 (50.8)	2 (50.8)
Length, in (mm)	13.2 (346)	13.2 (346)
Parking brake		
Type	Spring applied, hydraulic release disc	Spring applied, hydraulic release disc
Engagement	Depress on/off brake button on instrument panel, disconnect lapbelt, get off seat, or stop engine	Depress on/off brake button on instrument panel, disconnect lapbelt, get off seat, or stop engine

Skid Steer Specifications (Radial Lift)

HYDRAULIC SYSTEM	L213	L215
Pumps		
Type	Gear	Gear
Displacement standard aux., in ³ (cc)	1.24 (20.4)	1.24 (20.4)
Displacement high flow aux., in ³ (cc)	N/A	N/A
Pump flow, gpm (Lpm)	15.6 (59)	15.6 (59)
Optional high flow, gpm (Lpm)	N/A	N/A
Loader control valve		
Type	3 Spool / open center / series	3 Spool / open center / series
Relief pressure, psi (bar)	3000 (207)	3000 (207)
Hydraulic filter	6 micron / spin on	6 micron / spin on

CYLINDERS	L213	L215
Lift cylinder		
Bore diameter, in (mm)	2.25 (57)	2.25 (57)
Rod diameter, in (mm)	1.375 (35)	1.375 (35)
Stroke in, in (mm)	25.4 (645)	25.4 (645)
Closed length, in (mm)	38.9 (989)	38.9 (989)
Bucket cylinders		
Bore diameter, in (mm)	2.25 (57)	2.25 (57)
Rod diameter, in (mm)	1.25 (32)	1.25 (32)
Stroke, in (mm)	14.6 (370)	14.6 (370)
Closed length, in (mm)	23.4 (594)	23.4 (594)

WEIGHTS	L213	L215
Operating weight, lbs (kg)	5000 (2270)	5300 (2400)
Shipping weight, lbs (kg)	4700 (2130)	5000 (2270)

SERVICE CAPACITIES	L213	L215
Fuel tank, gal (L)	16 (60.5)	16 (60.5)
Engine oil with filter, qt (L)	7.9 (7.5)	7.9 (7.5)
Hydraulic system		
Reservoir, gal (L)	4 (15.13)	4 (15.13)
Chain tanks (per side), qt (L)	6.7 (6.3)	6.7 (6.3)

PERFORMANCE SPECS	L213	L215
Rated operating load		
50% tip, lbs (kg)	1300 (590)	1500 (680)
Tipping load, lbs (kg)	2600 (1179)	3000 (1361)
Breakout forces		
Lift cylinder, lbs (kN)	4275 (19)	4275 (19)
Bucket cylinder, lbs (kN)	4150 (18.5)	4150 (18.5)
Cycle times		
Raise, sec	3.4	3.4
Lower, sec	2.1	2.1
Dump, sec	1.9	1.9
Roll back, sec	1.3	1.3

For all Dimensions and Performance Metrics, unless otherwise specified:

L213 – Equipped with 175 lb operator, 60" Dirt & Foundry Bucket and 10 x 16.5 tires

L215 – Equipped with 175 lb operator, 60" Dirt & Foundry Bucket and 10 x 16.5 tires

L213 L215 L218 L220 L223 L225 L230 200 SERIES SKID STEER LOADERS

Built Around You

Introducing the new 200 Series skid steer loaders. **With five years in the making, they're bigger, badder and better!**

New Holland engineers used input from hundreds of customers to design our new line of skid steers. Designed from the ground up, these machines were built around you. No matter what your line of work – agriculture, landscaping or construction – you'll work faster, smarter and more profitably with our new skid steers.

- New Holland's patented vertical lift Super Boom® design has best-in-class forward dump height and reach. It's more efficient to load materials to the center of the truck.
- Our industry leading bucket breakout force and dump angle provide fast cycle times and improve productivity.
- With the longest wheelbase in the industry and a low center of gravity, New Holland skid steers are the most stable machines on the market. Confident operators get more work done.
- Need more room? The widest, most comfortable cab in the industry gives you more head and foot room, and offers twice the visibility in critical zones. Better visibility allows safe and efficient movement around the worksite.
- Comfortable operators get more work done. Just a few new convenience features include: keyless start, a Glide Ride option, available heated or air-ride seat and a self-leveling bucket feature.
- Daily maintenance just got easier. Our ground-level service checkpoints are easy to access and grouped together. Plus, the new flip-top cab tilts forward for complete component access.



With over 55 attachments available for the new 200 Series skid steers, these machines are multi-task masters! Whether you work in agriculture, landscaping or construction, New Holland delivers the equipment to get the job done right.



New Holland Construction
700 State Street
Racine, WI 53402
866-726-3396 Toll Free
262-636-6011

New Holland Construction Equipment is backed with a **1-Year/Unlimited Hour Standard Warranty.**

Design, materials and/or specifications are subject to change without notice and without liability therefor. Specifications are applicable to units sold in Canada, the United States, its territories and possessions, and may vary outside these areas.

© 2010 CNH America LLC. All rights reserved. New Holland is a trademark of CNH America LLC. Any trademarks referred to herein, in association with goods and/or services of companies other than CNH America LLC, are the property of those respective companies.



Safety begins with a thorough understanding of the equipment. Always make sure you and your operators read the Operator's Manual before using the equipment. Pay close attention to all safety and operating decals and never operate machinery without all shields, protective devices and structures in place.

Stock #NHC201011SSLPrelim • PRINTED IN U.S.A.

 Printed on recycled paper

www.newholland.com

Courtesy of Machine.Market