



*Equipment includes options and extra equipment.*

## Features

Semmco Alpha 30 is a diesel hydraulic mobile concrete sprayer designed for tunnel profiles up to 7 m in height and 9 meters in width. The maximum longitudinal spraying reach from one set up is 3 m.

The new NSP 30 concrete pump has a theoretical maximum pumping capacity of 30 m<sup>3</sup>/h. Alpha 30's accelerator dosing system uses a peristaltic pump and has two stainless steel tanks with a total volume of 420 liters.

Alpha 30 can be equipped with a radio or wired remote control system for controlling boom and nozzle movements and rotation as well as accelerator dosing and concrete pump.

To make manouvering easy in narrow tunnels Alpha 30 has four wheel steering and four wheel drive. It has a 120 kW Liquid cooled turbo charged diesel engine meeting Tier III regulations.

Operators canopy on Alpha 30 is FOPS and ROPS approved.

Standard equipment includes Fogmaker fire suppression system. The additional equipment for Alpha 30 are high pressure washer system with 300 liter stainless steel water tank, spare wheel and wired remote control plus cable.

Normet reserves the right to change this specification without further notice.

### Technical specification

#### SPRAYBOOM

Automatic functions:

- Nozzle rotation

The speed of the movements can be adjusted from the radio remote control

All the movements are pressure compensated and have a proportional output

Boom coverage for tunnels up to 7 m x 7 m

#### CONCRETE PUMP

Spray pump NSP 30

Low-wear and low-maintenance double piston pump:

- Pumping capacity theoretical 3 - 30 m<sup>3</sup>/h
- Pumping cylinder diameter 200 mm
- Cylinder stroke 600 mm
- Pumping pressure max. 50 bar
- Hydraulic pressure max. 190 bar

High pumping pressure enables the conveying of stiff concrete

The pump is able to pump up to max. aggregate size of 16 mm (including crushed) and all types of fibres (max. length 60 mm) in the mix

Hydraulically driven agitator

#### RADIO REMOTE CONTROL SYSTEM

Following features can be adjusted or switched on/off from the control box:

- Accelerator dosing rate
- Accelerator pump on/off
- Concrete pump on/off/reverse
- Nozzle rotation on/off

#### ACCELERATOR SYSTEM

Hydraulically driven Peristaltic pump

Max. pumping pressure 7 bar

Dosing rate 0.5...16 L/min (30 - 960 L/h)

Suction line diameter 1" (25 mm)

Pressure line diameter 1" (25 mm)

Additive tank capacity 420 L. Stainless steel

#### CONCRETE LINE

Concrete line diameter 65 mm.

#### AIR HOSE REEL

Manually operated reel

- Hose length 30 m
- Hose size 1 1/2" (38 mm)

#### ENGINE

Liquid cooled turbo charged Deutz TCD 2013 L4, 120kW/2300 rpm, TIER 3 approved

#### DRIVER'S COMPARTMENT

Open 1-man canopy. FOPS / ROPS approved

Suspended driver's seat

Seat with pressure sensor (dead man)

Seat with retractable (75 mm wide) lap seat belt

The driver's compartment with driving controls and pedals.

VDO gauges (IP65):

- Master Gauge: Engine RPM  
Hourmeter  
Voltmeter  
Fuel Consumption  
Turbocharger pressure

- Fuel level
- Engine temperature

Window kit is included

#### EXHAUST SYSTEM

Catalytic exhaust gas purifier and muffler

#### TRANSMISSION

Hydrostatic 4-wheel transmission

Variable piston pump 56 cm<sup>3</sup>

Variable piston motor 115 cm<sup>3</sup>

Stainless steel hydraulic oil tank

#### AXLES

Planetary type

Dana 212

Rear end axle fixed

Boom end axle oscillation +/- 7°

#### TYRES

10.00 - 20 XDY MICHELIN

#### PERFORMANCE

Max. tractive effort 44 kN

Max. speed (horizontal tunnel) 20 km/h

#### BRAKES

Service brake: hydraulically powered two-circuit oil-immersed multi-disc brakes in both axles

Safety/Parking brake: spring-activated, hydraulically released, fail-safe-type brake.

#### STEERING

Four-wheel steering as standard

Orbitrol type

Including crabwalk

#### FUEL TANK

Capacity 165 L. Stainless steel

Normet reserves the right to change this specification without further notice.

### Technical specification

#### HYDRAULIC SYSTEM

Variable displacement piston pump system with following outputs:

- 90 L/min for concrete pump (piston type)
- 90 L/min for boom (piston type)

Hydraulic oil tank capacity 500 L. Stainless steel

Oil cooler for concrete and boom circuit

Return oil filtration 10 µm

Oil level and temperature indication

Return filters with contamination indicator

#### 24 VDC ELECTRICAL SYSTEM

Exposed components are min. IP 65 standard

Battery 2 x 80 Ah

Alternator 55 A

Wire harness (self extinguishing) with tinned wires and watertight conduits

LED driving lights:

- Front end, LED lights 2 x 1300 lm
- Rear end, LED lights 2 x 1300 lm

Service brake lights

LED directional lights on front and back side

#### WORKING LIGHTS

24 VDC LED lights

2 pcs on boom of 6700 lm

1 pc over the concrete pump

#### GREASING MANIFOLD

Centralized grease fittings for:

- Concrete pump

#### FIRE SUPPRESSION SYSTEM

**Fogmaker:** Automatically and manually actuated

### Optional Equipment

#### ENGINE

Air cooled turbo-charged Deutz TCD 914 L06, 125 kW/2300 rpm, TIER 2 approved

#### LOWER DRIVER'S COMPARTMENT

Open 1-man canopy. Not FOPS / ROPS certified

Suspended driver's seat

Seat with pressure sensor (dead man)

Seat with retractable (75 mm wide) lap seat belt

The driver's compartment with driving controls and pedals

Window kit is included

### Additional Equipment

#### HIGH PRESSURE WASHER

**Hydraulically operated pressure washer with hose reel:**

- Max. water pressure 100 bar
- Max. water flow 15 L/min

**Manually operated hose reel**

- Hose size 3/4" (19 mm)
- Stainless steel tank; capacity 300 L

#### FOR ENCLOSED CABIN

**Options available only for Tier III equipment.**

**Cabin ventilation:**

- Cabin Heating
- Air conditioning.

#### GREASING SYSTEM

**Automatic greasing system for the concrete pump.**

#### FORM OIL SYSTEM

**Air pressure-driven system with hose reel:**

- Tank Capacity 40L
- Hose length 30m
- Working pressure 7 bar

#### REMOTE CONTROL SYSTEM

**Wired remote control including:**

- Remote control box
- Remote control cable 10 m

#### SPARE WHEEL

**10.00 - 20 XDY3 MICHELIN with steel rim**

### Additional Equipment

#### SAFETY EQUIPMENT

##### Reversing camera

- Infrared LEDs for ultra-low light performance
- Illumination distance 5m
- Heater
- Day/Night sensor

##### Obstacle detection system

- Two units ultrasound sensor , adjustable detection distance up to nine meters.
- Two units ultrasound sensor, fix detection distance for blind spots.
- Cabin display with audio and visual signals.

#### OTHER

6 kg hand held fire extinguisher

Standard symbol labels

Text labels in : Spa / Eng

Basic tool set:

- Cleaning plug
- Washing ball
- Rubber hose 3/4" 4 m
- Suction hose 1" 4 m
- Sledge hammer 800 g
- Special tools for concrete pump

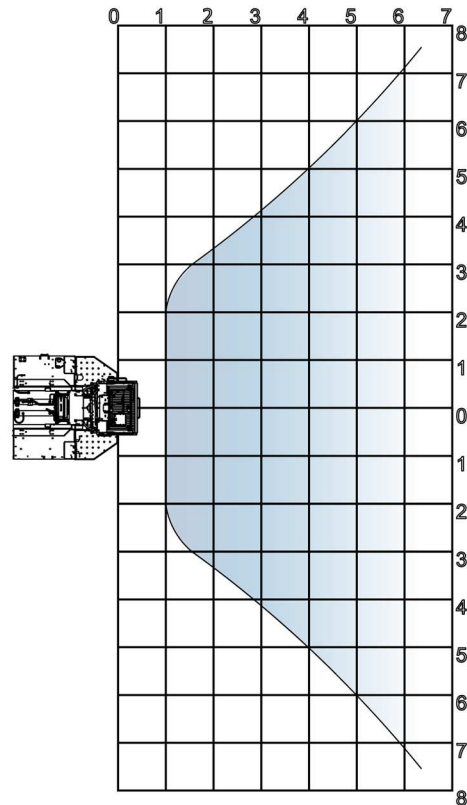

#### TOP VIEW

Reversing camera coverage diagram.

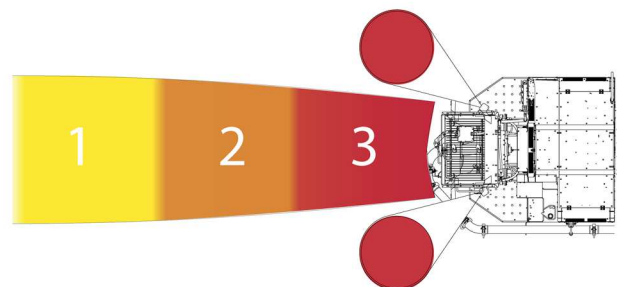
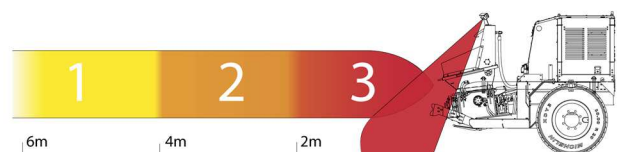

#### TOP AND SIDE VIEW

Obstacle detection system diagram.

Normet reserves the right to change this specification without further notice.

### Dimensions

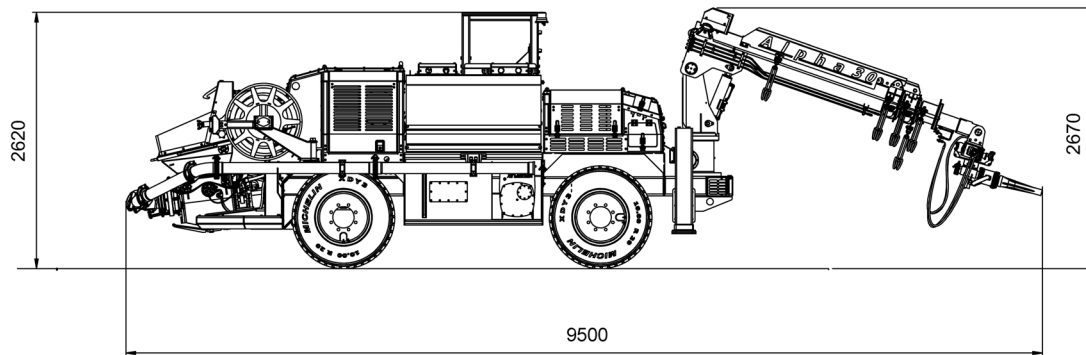

#### SIDE VIEW 1

Basic machine. Driving dimensions at job site  
Driver compartment correspond at the standard FOPS / ROPS approved cabin.

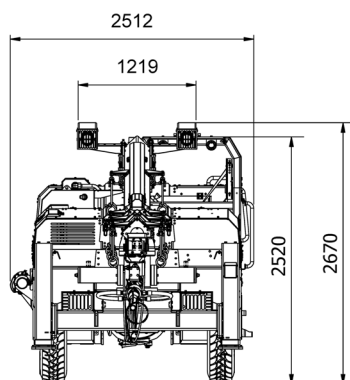
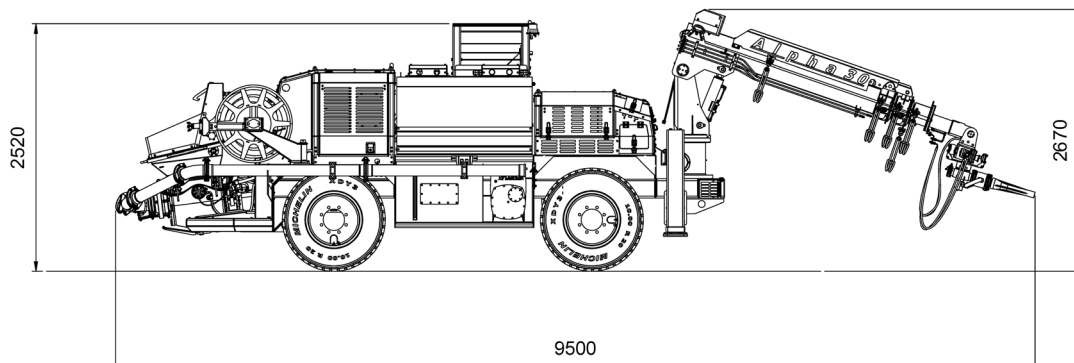

#### SIDE AND FRONT VIEW 2

Basic machine. Driving dimensions at job site  
Optional driver compartment correspond at the Not FOPS / ROPS certified.

Normet reserves the right to change this specification without further notice.

### Dimensions

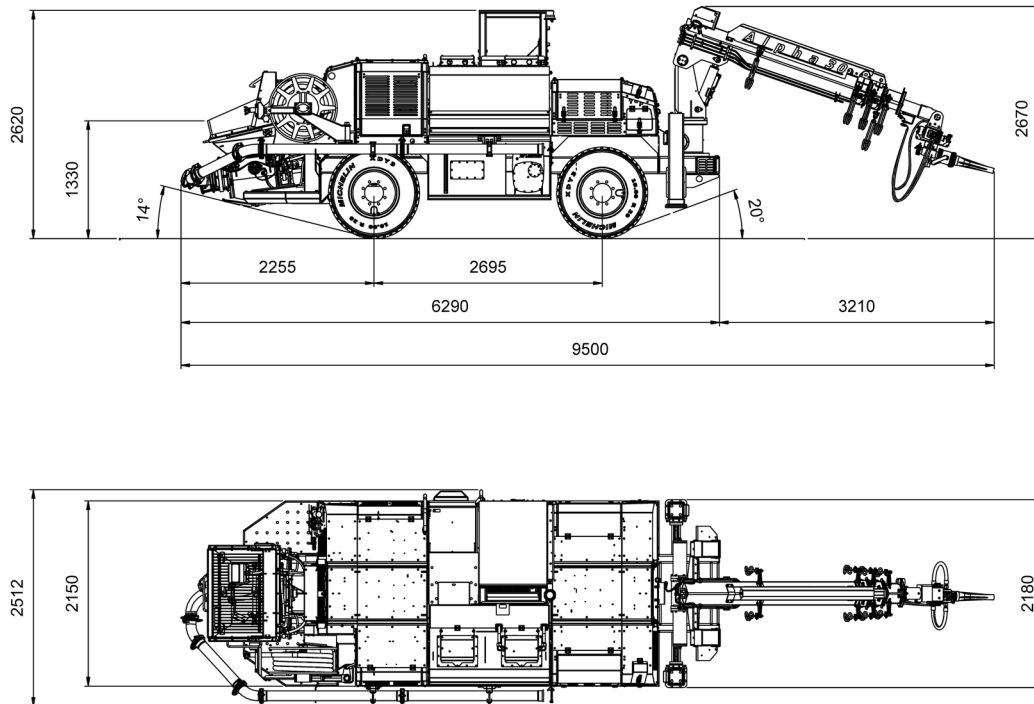

### SIDE AND OVERVIEW 3

Basic machine. Driving dimensions at job site

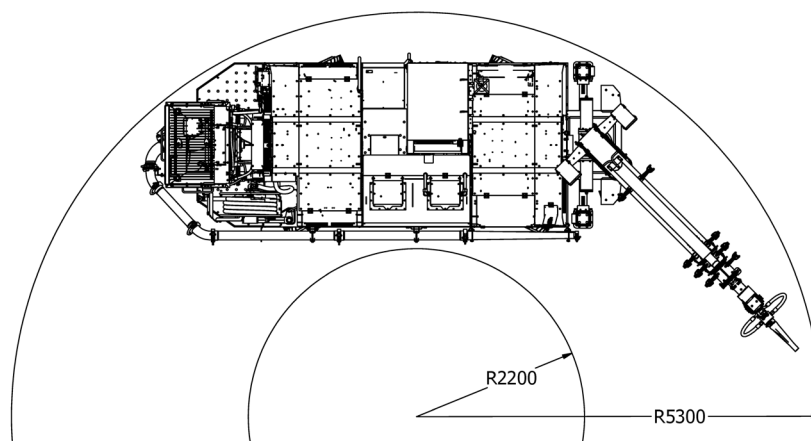

### TURNING RADIUS

#### DIMENSIONS

Length	9500 mm
Width	2512 mm
Height	2670 mm
Wheel base	2695 mm
Ground clearance	448 mm

#### TURNING RADIUS

Outer	5300 mm
Inner	2200 mm

#### WEIGHT

Operating	9500 kg
-----------	---------

Normet reserves the right to change this specification without further notice.

# normet

## Semmco Alpha 30

Technical data sheet  
100037843.4  
18.12.2013

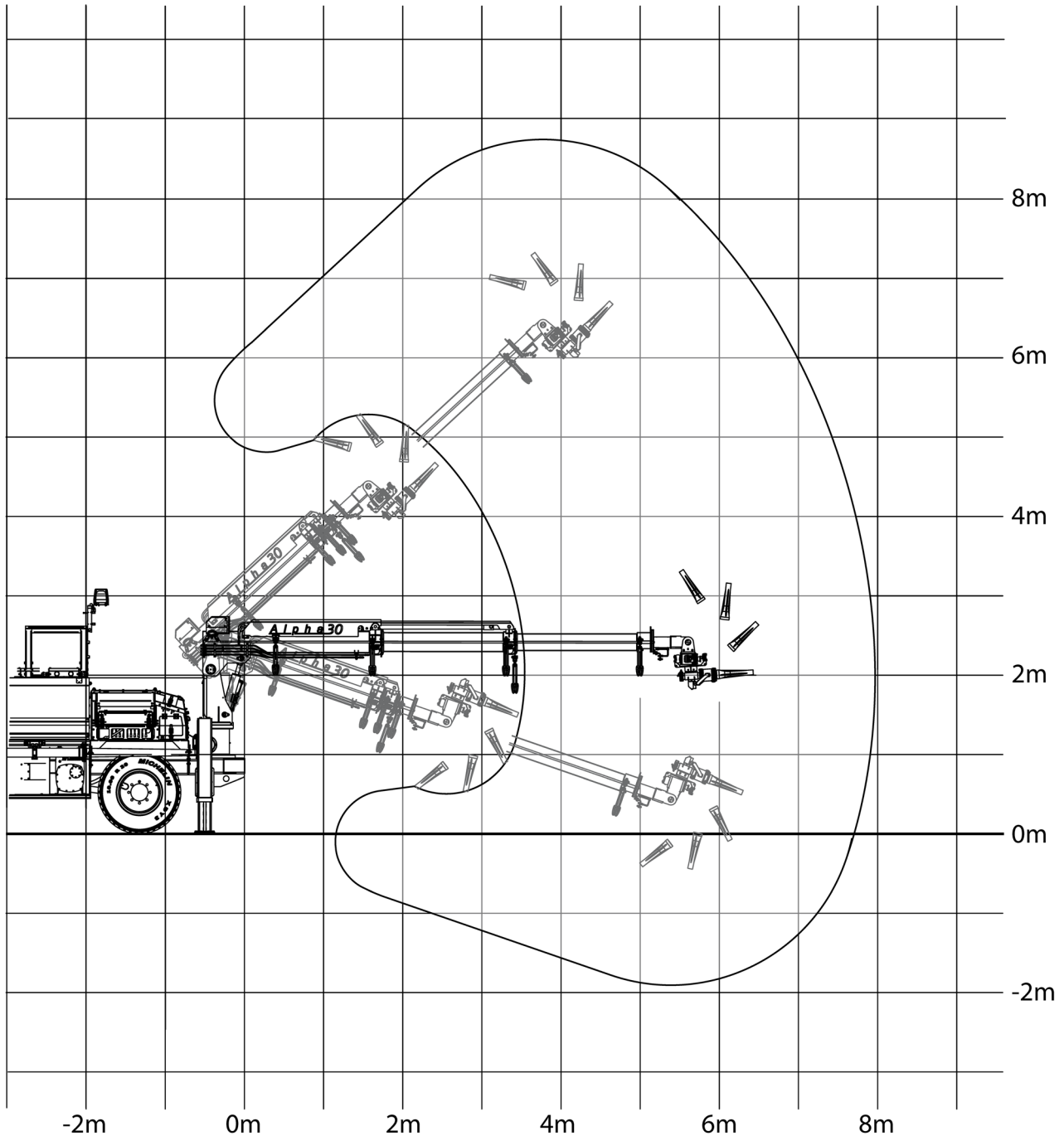

### COVERAGE AREA OF SPRAY BOOM

Normet reserves the right to change this specification without further notice.

**Normet Chile Ltda.**  
Av. Chena #11000  
Parque industrial Puerta sur  
Santiago - Chile

7/10

Tel : +56 (2) 29638600  
e-mail: info@normet.com

Courtesy of Machine.Market

# normet

## Semmco Alpha 30

Technical data sheet  
100037843.4  
18.12.2013

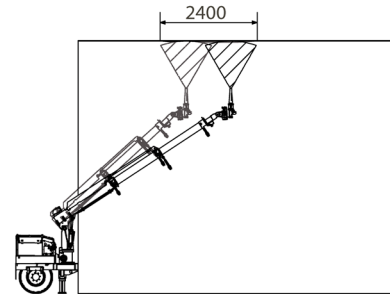
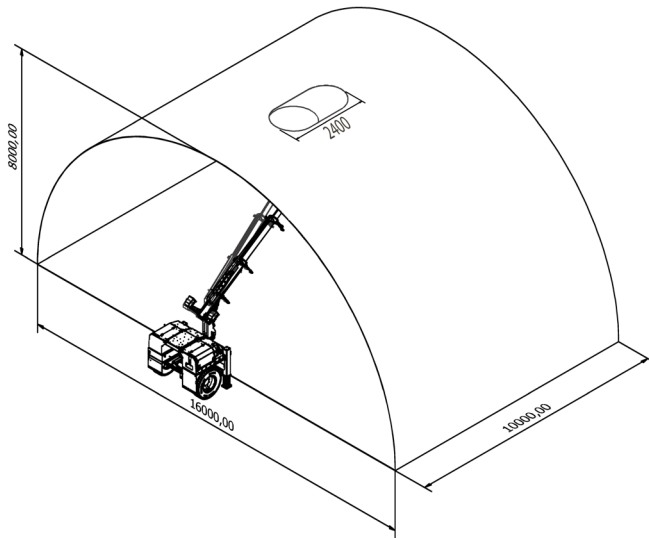

8 meter high tunnel

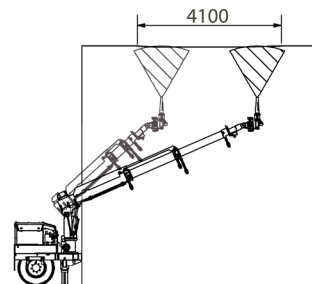
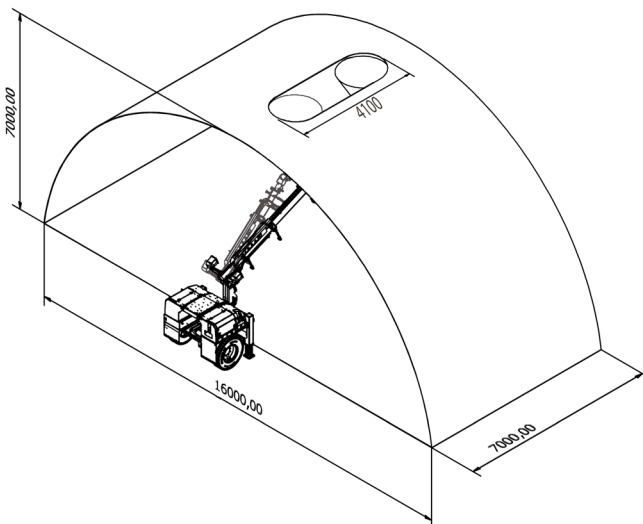

7 meter high tunnel

### COVERAGE AREA OF SPRAY BOOM

Normet reserves the right to change this specification without further notice.

**Normet Chile Ltda.**  
Av. Chena #11000  
Parque industrial Puerta sur  
Santiago - Chile

8/10

Tel : +56 (2) 29638600  
e-mail: info@normet.com

Courtesy of Machine.Market



# normet

## Semmco Alpha 30

Technical data sheet  
100037843.4  
18.12.2013

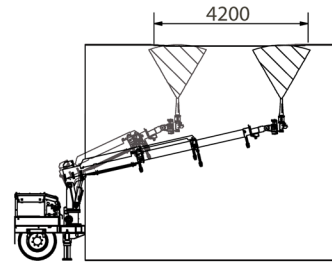
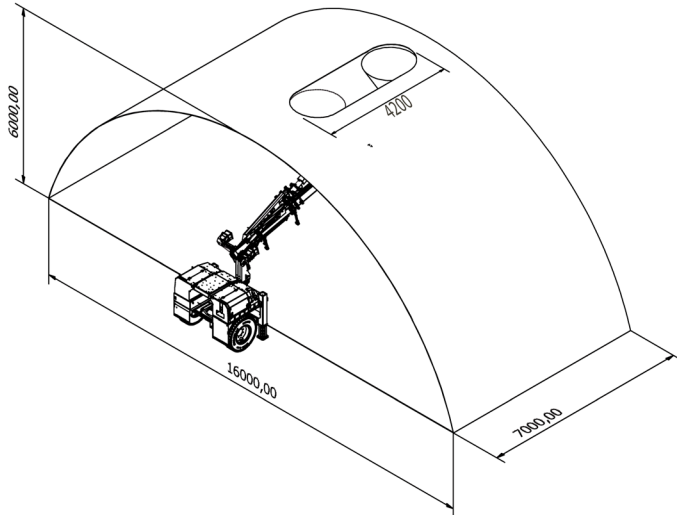

6 meter high tunnel

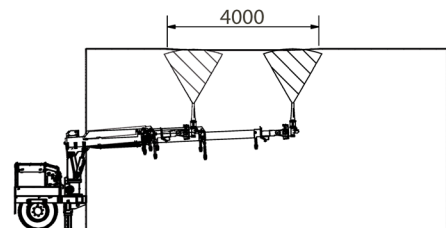
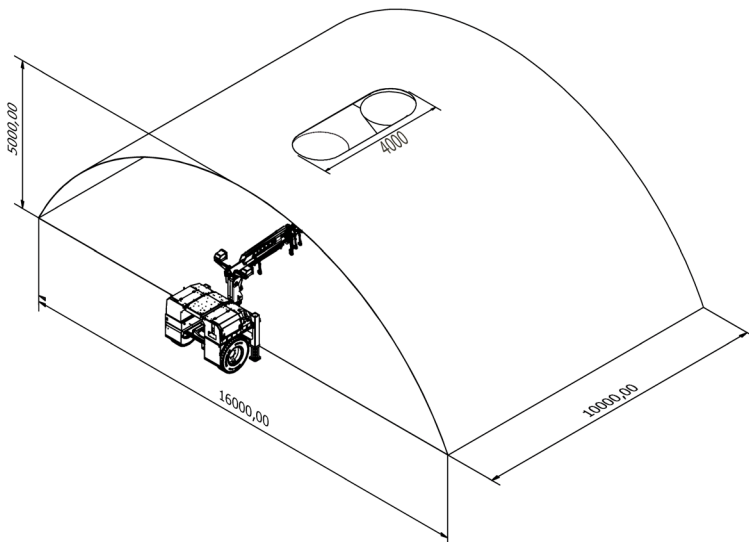

5 meter high tunnel

### COVERAGE AREA OF SPRAY BOOM

Normet reserves the right to change this specification without further notice.

### Tractive Effort

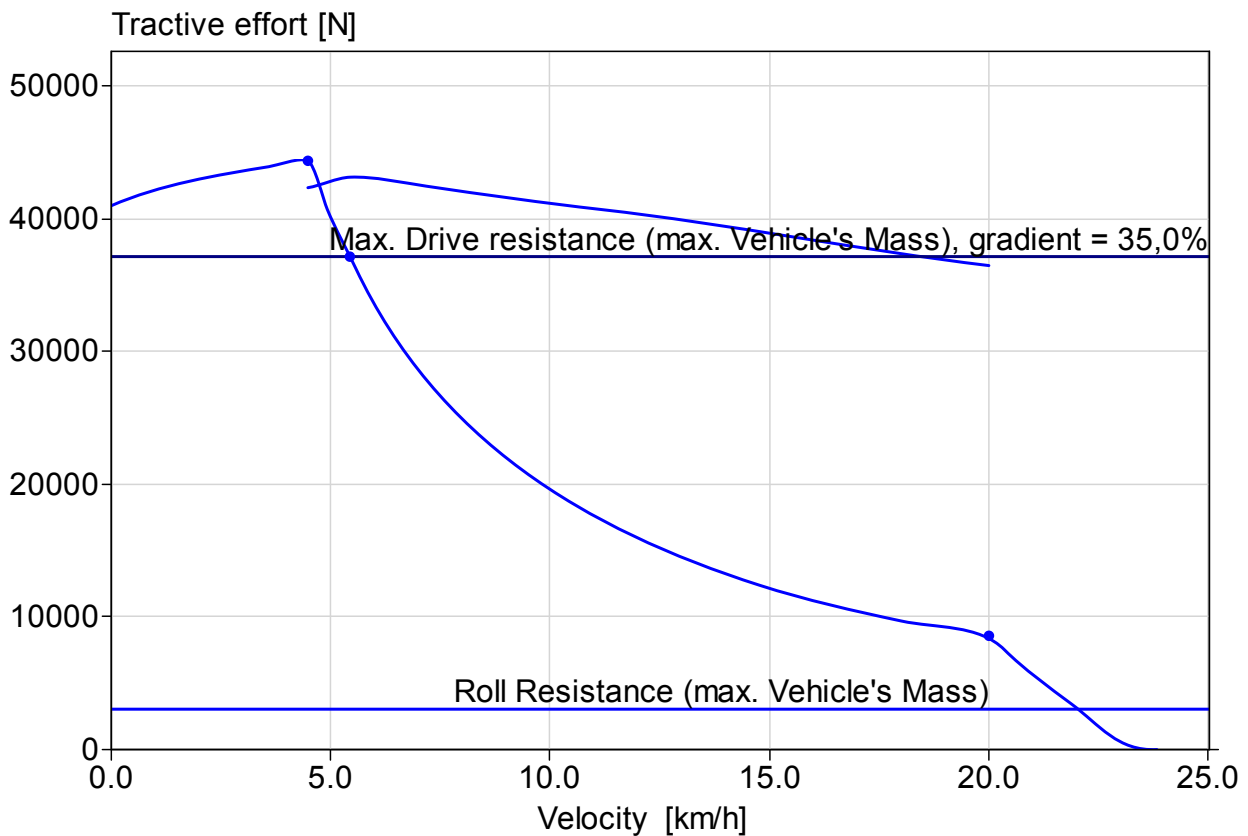

Normet reserves the right to change this specification without further notice.