

normet**Normet Corporation**

Ahmolantie 6

FI-74510 IISALMI, FINLAND

Tel +358 (0) 17 83 241

Fax +358 (0) 17 823 606

Variomec 1060 D

TI 1800014

DRW

DATE 22.11.2007

PAGE 1 / 3

APPR. 05.09.2008

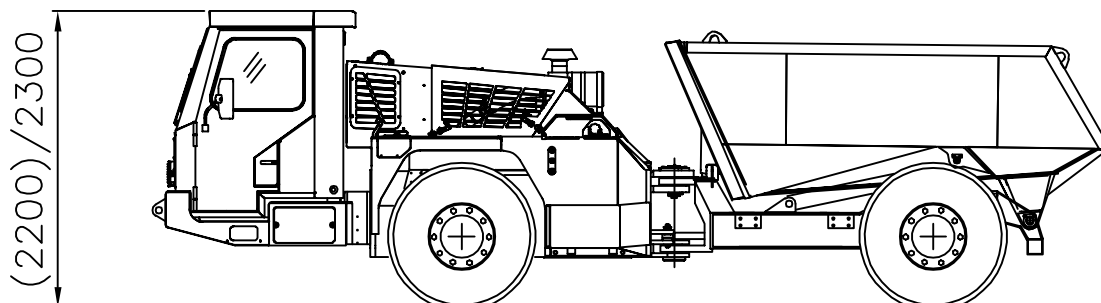
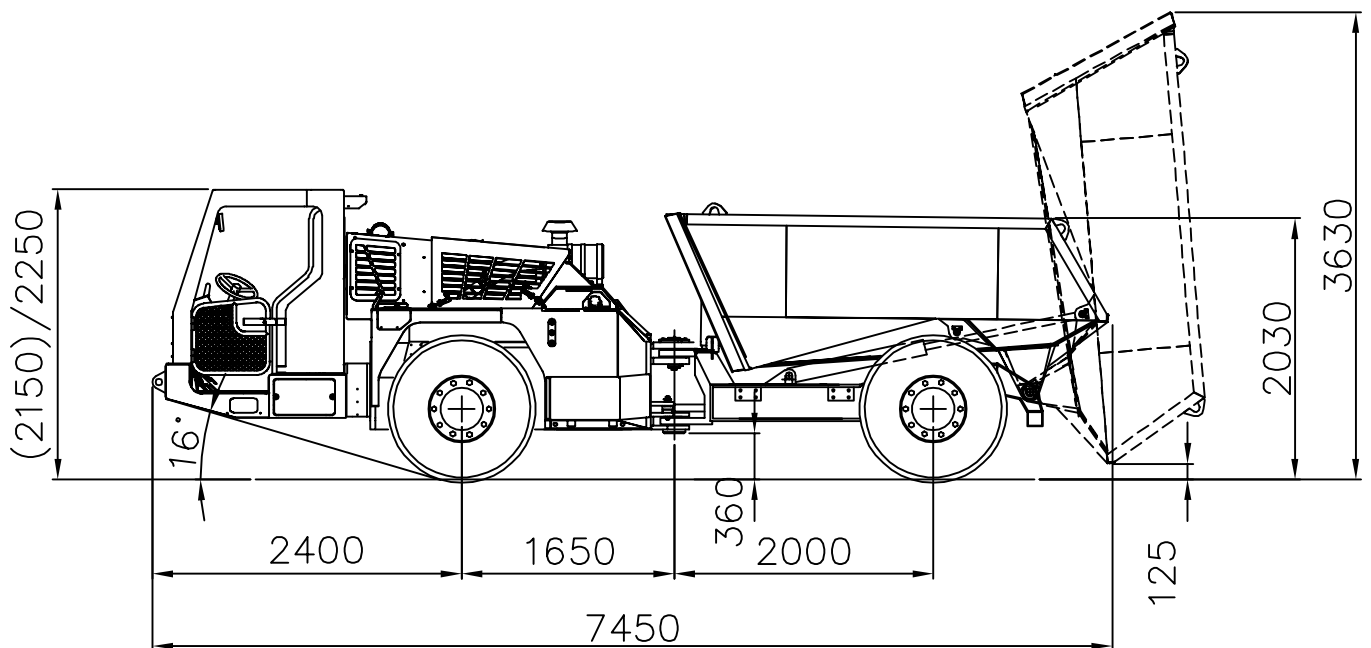

normet

Normet Corporation
Ahmolantie 6
FI-74510 IISALMI, FINLAND
Tel +358 (0) 17 83 241
Fax +358 (0) 17 823 606

Variomec 1060 D

TI 1800014
DRW
DATE 22.11.2007
PAGE 2 / 3
APPR. 05.09.2008

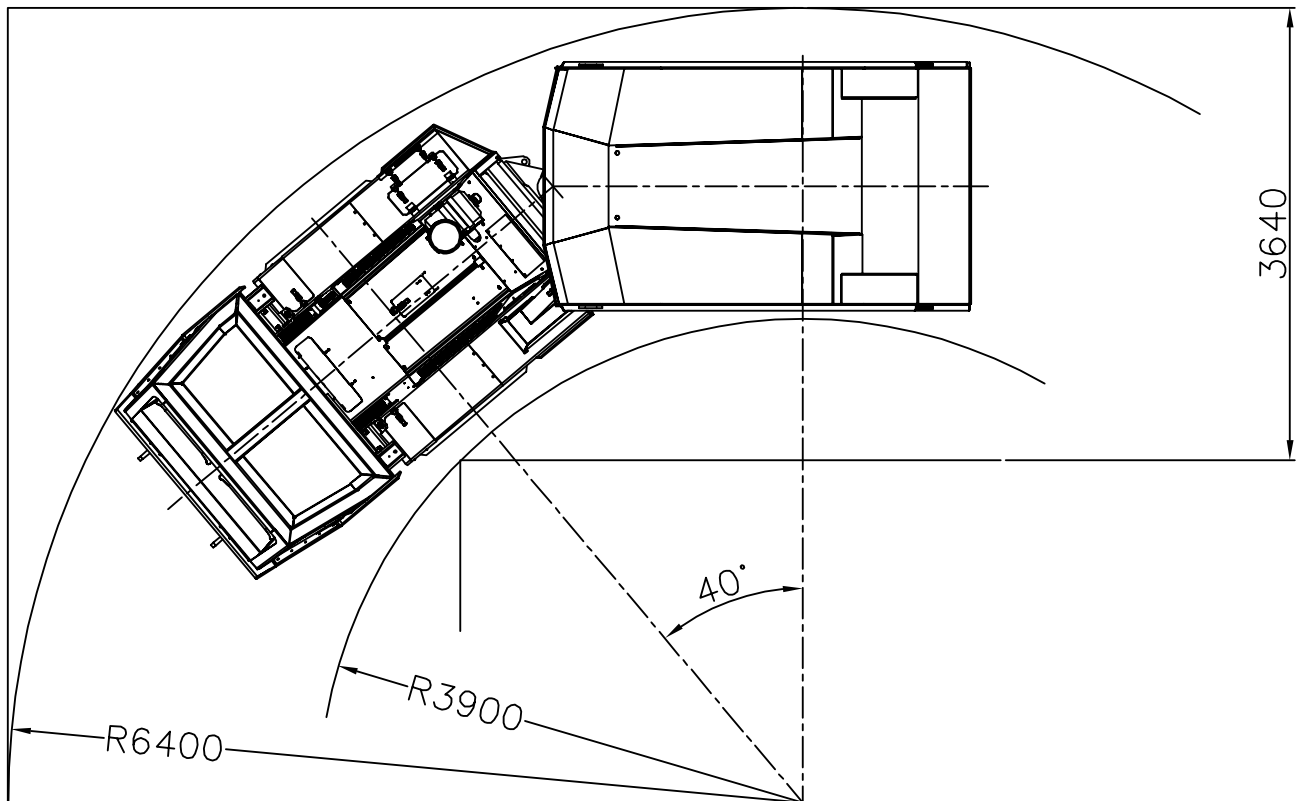
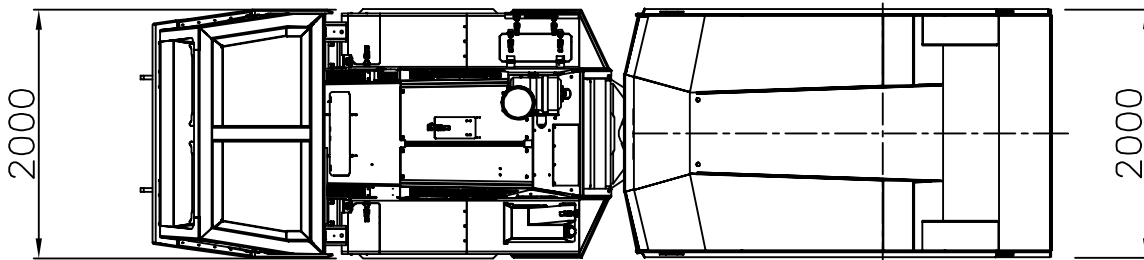

normet**Normet Corporation**

Ahmolantie 6

FI-74510 IISALMI, FINLAND

Tel +358 (0) 17 83 241

Fax +358 (0) 17 823 606

Variomec 1060 D

TI 1800014

DRW

DATE 22.11.2007

PAGE 3 / 3

APPR. 05.09.2008

DIMENSIONS

Length	7450 mm
Width	2000 mm
Height	(2150 mm) 2250 mm
Wheel base	3650 mm
Track	1650 mm
Ground clearance	360 mm

WEIGHT

Operating	9800 kg
Max. payload	10000 kg

TURNING RADIUS

Outer	6400 mm
Inner	3900 mm

DUMP PUCKET

Volume	6 m ³
Tipping angle	85°
Tipping height	3630 mm

PERFORMANCE CURVE**17100043**

1st gear	max. 5 km/h
2nd gear	10 km/h
3rd gear	25 km/h
Max. tractive effort	132 kN

TRANSMISSION

Dana Spicer powershift
3 speeds forwards and reverse
4-wheel drive

AXLES

Planetary type
rear axle fixed
front axle oscillation +/- 10°

TYRES

12.00 - 20 PR 18

BRAKES

Service brake: hydraulically powered two-circuit oil immersed multidisc brakes in both axles

Safety/Parking brake: hydraulically released fail-safe - type brake

STEERING

Hydraulic frame steering,
Orbitrol type
Frame articulation +/- 40°

HYDRAULICS

190 bar, 100 l/min/2200 rpm
for steering and brakes
200 bar, 105 l/min/2200 rpm for remixer

ENGINE

Deutz TCD 2013 L4
120 kW/2300 rpm

ELECTRICAL SYSTEM

24 V negative ground
Battery 2 x 110 Ah
Alternator 80 A
Lights (2+2) x 70 W

OPTIONS AND ACCESSORIES:**ENCLOSED CABIN****CABIN HEATING****AIR CONDITIONING****ENGINE**

MB OM 904 LA
110 KW/2200 rpm

RETARDER

Mounted in driveline
Electromagnetic type
Recommended on inclines deeper than 1:10 and longer than 1000 m