



Ommel lift

**Top safety with
this handy electro-
hydraulically
operated lift**

**Type 1050 E
Trailer-mounted**

CE

SAFE ACCESS - made of steel

Technical data:

1050 EZ Trailer-mounted

Max. working height	10.5 m
Max. outreach	6.8 m
Max. basket load	125 kg
Rotation	± 355°
Basket size	0.7x0.7x1.1 m
Power supply	230V/10A
Travelling length	5.90/4.91 m*
Travelling height	1.95 m
Travelling width	1.20/0.78 m
Operational width	3.40 m
Total weight	995 kg
Hydraulic stabilizers	+
230 V outlet in basket	+
2-step controls	+
Adjustable travelling width	+

+ Standard

* With reduced travelling length

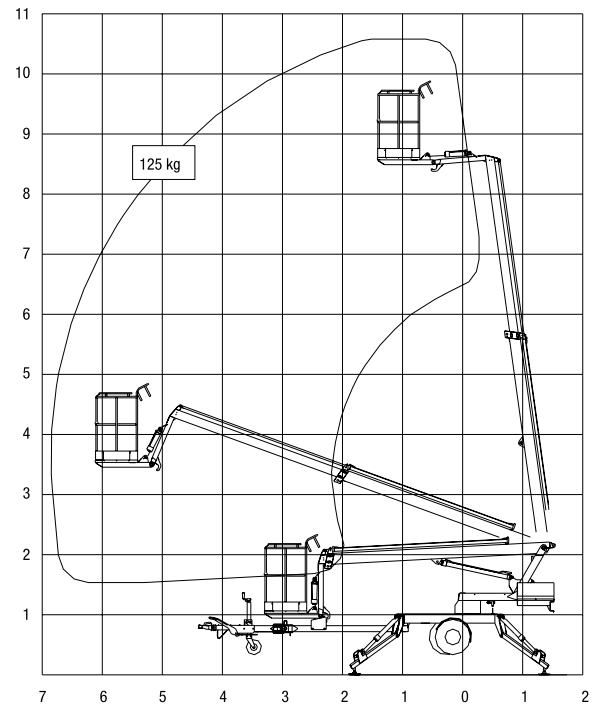

»Compact and flexible«



Type 1050 EZ

Is driven by a 230 volt-electronic motor which can be connected to a mains with a fuse of only 10 A. Type 1050 EZ is particularly suited for continuous operation.

Type 1050 EZ

Standard features include hydraulic stabilizers and 2-step dual controls to ground and basket. Design features include a basket mounting that forms a "fly" boom mounted to the top boom section and gives increased outreach over roof edges or other obstacles. The specially designed steel booms made from high and broad profiles allow a great outreach with an exceptional degree of stability and rigidity. The wiring is protected inside the boom system.

Adjustable travelling width

As standard the lift is equipped with an adjustable wheel axle which means that the lift with the wheels in the outer position is very stable during towing. Furthermore, it is possible to reduce the travelling width, so that the lift can pass through a 0.8 m doorway.

Reduced travelling length

Through an easy system the front part of the towing bar can be turned around a link reducing travelling length by almost 1 m. Together with the adjustable wheel axle this makes the lift extremely compact and flexible.