

50/55tm

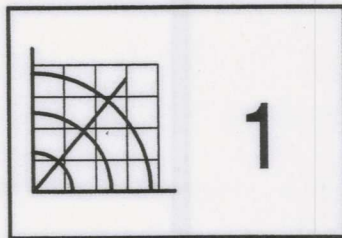

129259-1

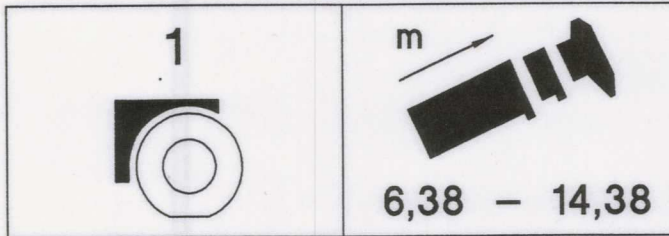

DIN

25-22 [t]	6
22 [t]	4

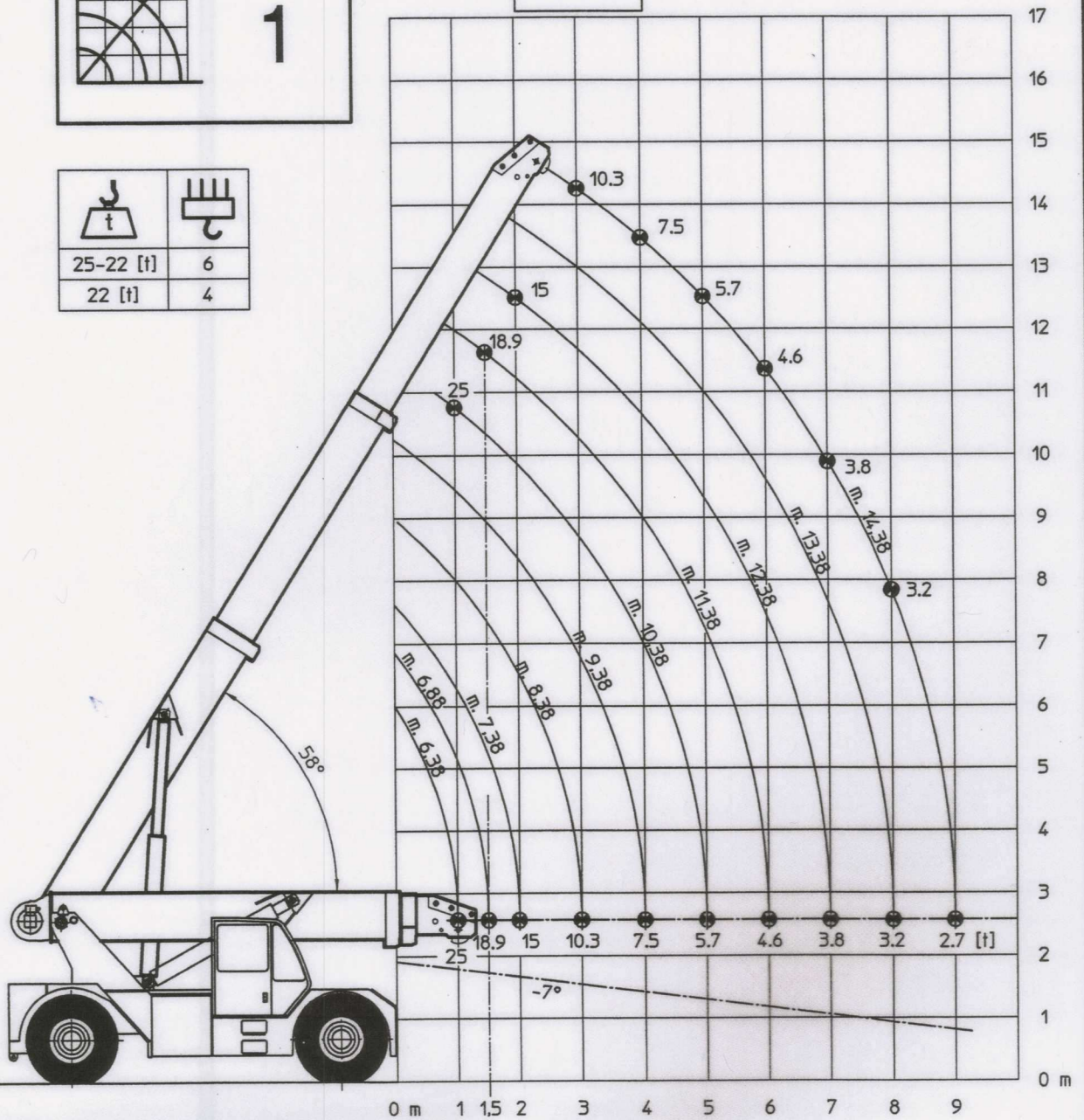

10 bar	48 km/h		1 km/h

50/55tm

ORMIG

129260-1

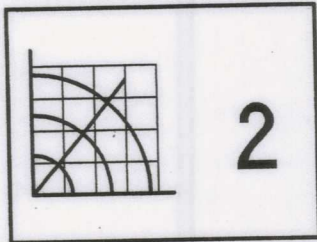
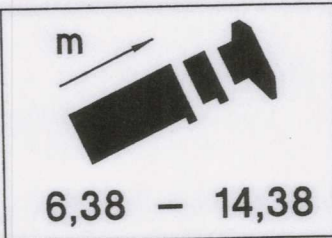
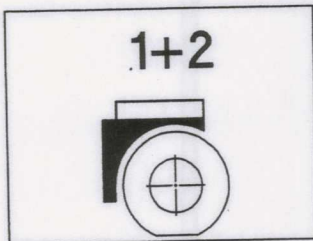

DIN

34,5 - 33 [t]	8
33 - 22 [t]	6
22 [t]	4

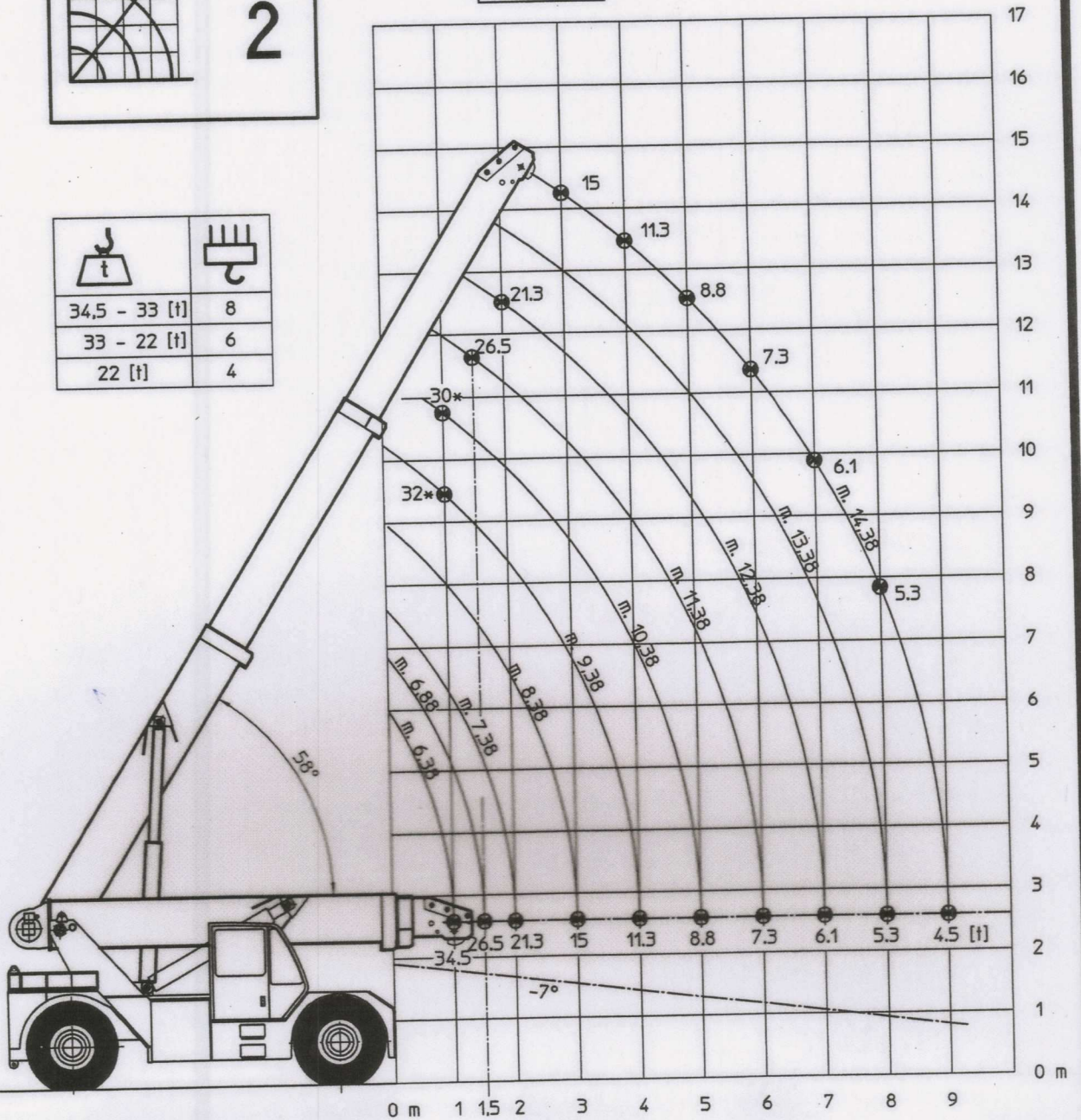

10 bar	B6		
	48 km/h		1 km/h

50/55tm



129261-1

1+2+3

m

6,38 - 14,38

3

DIN

50 - 44 [t]	10
44 - 33 [t]	8
33 - 22 [t]	6
22 [t]	4

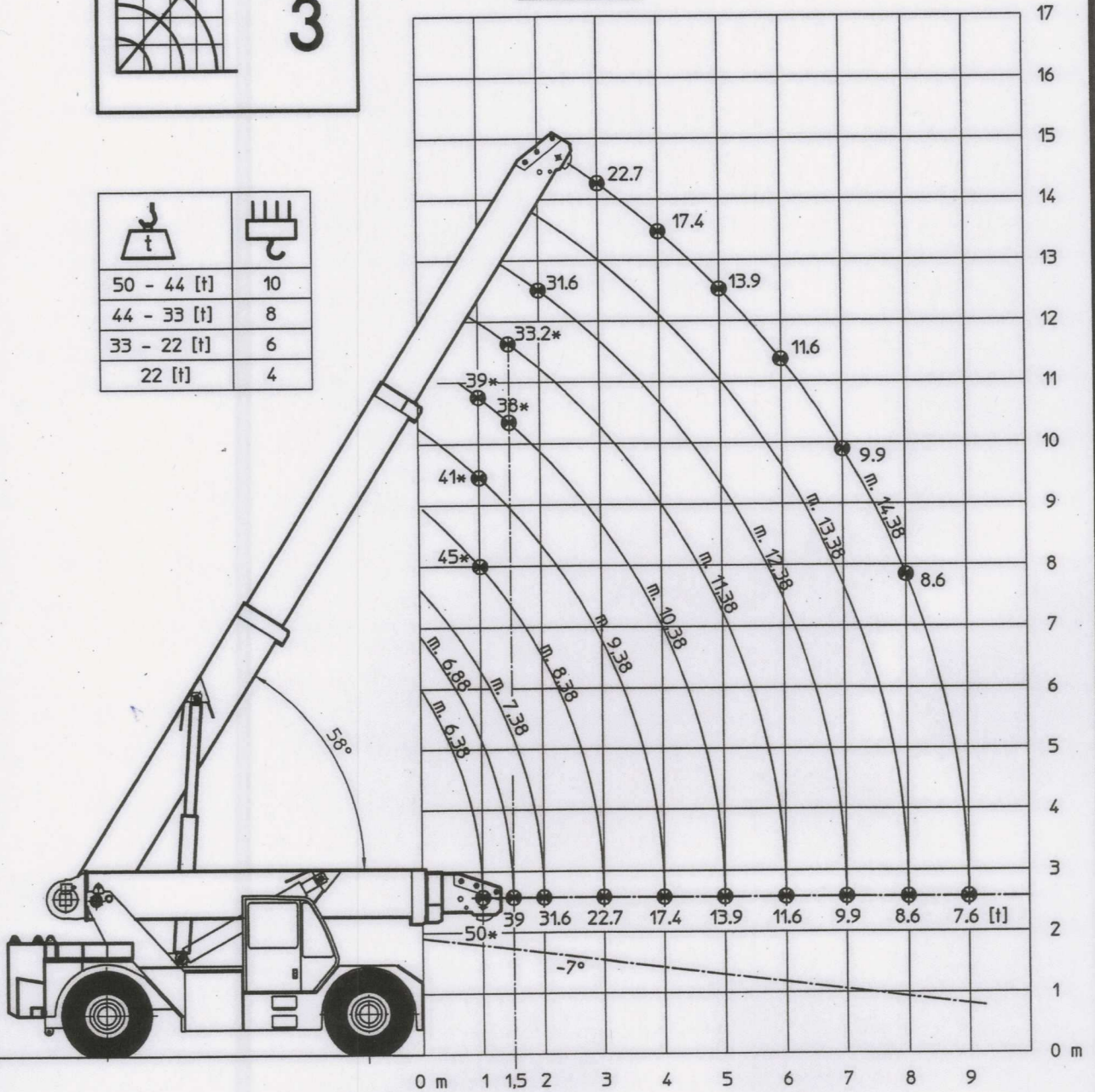

10 bar

B6

48 km/h

5 km/h

1 km/h

50/55tm

ORMIG

129258-1

1+2+3+4+5

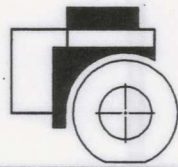

m

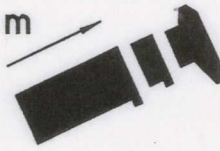

6,38 - 14,38

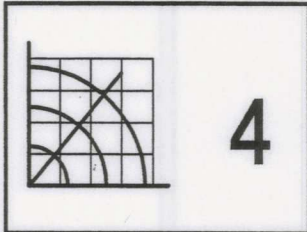

4

DIN

55 - 44 [t]	10
44 - 33 [t]	8
33 - 22 [t]	6
22 [t]	4

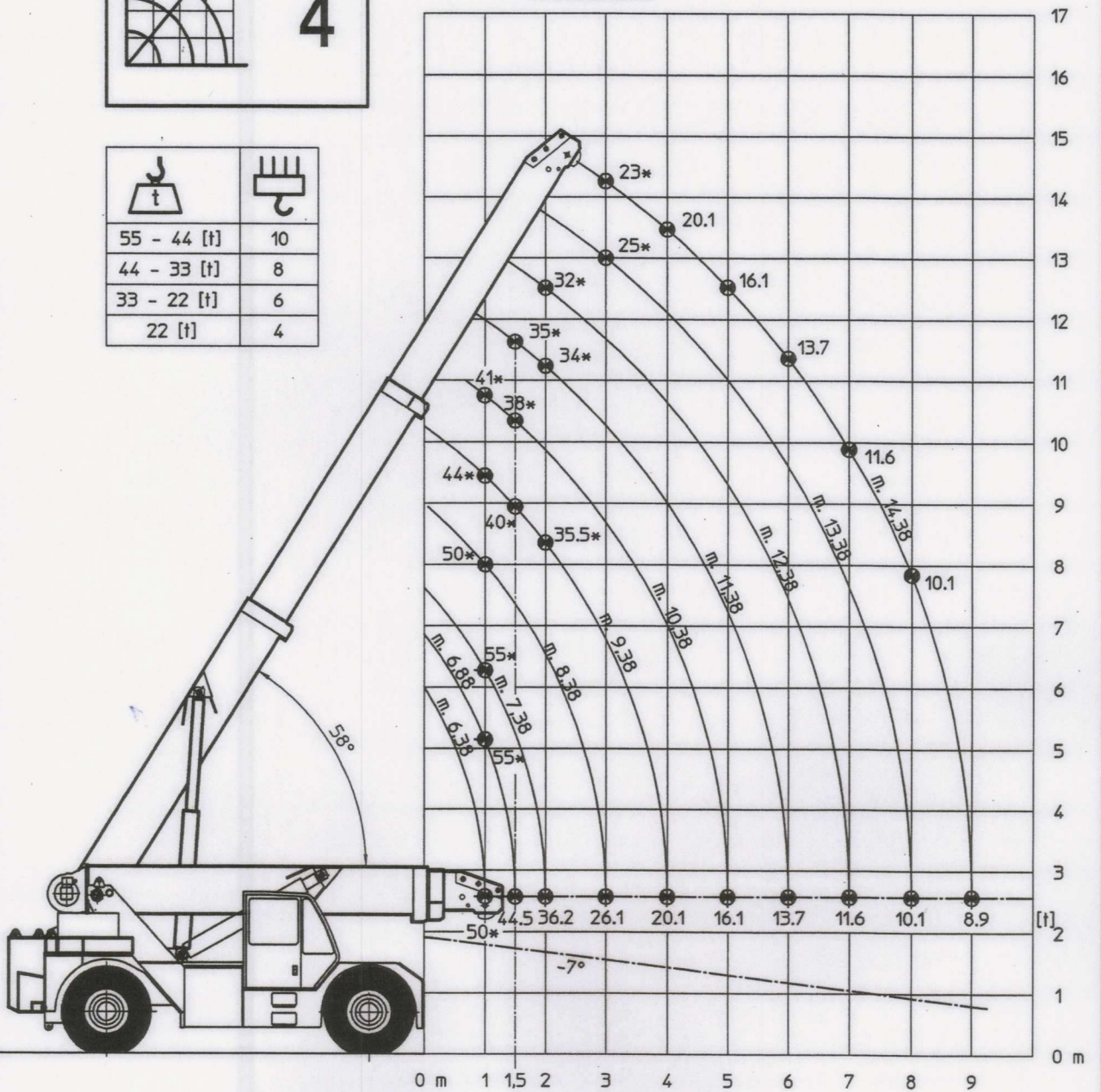

50/55tm

ORMIG

129262-1

1+2+4+5



m

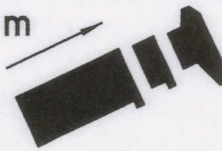

6,38 - 14,38

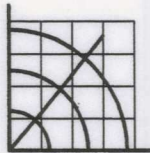

5

DIN

41 - 33 [t]	8
33 - 22 [t]	6
22 [t]	4

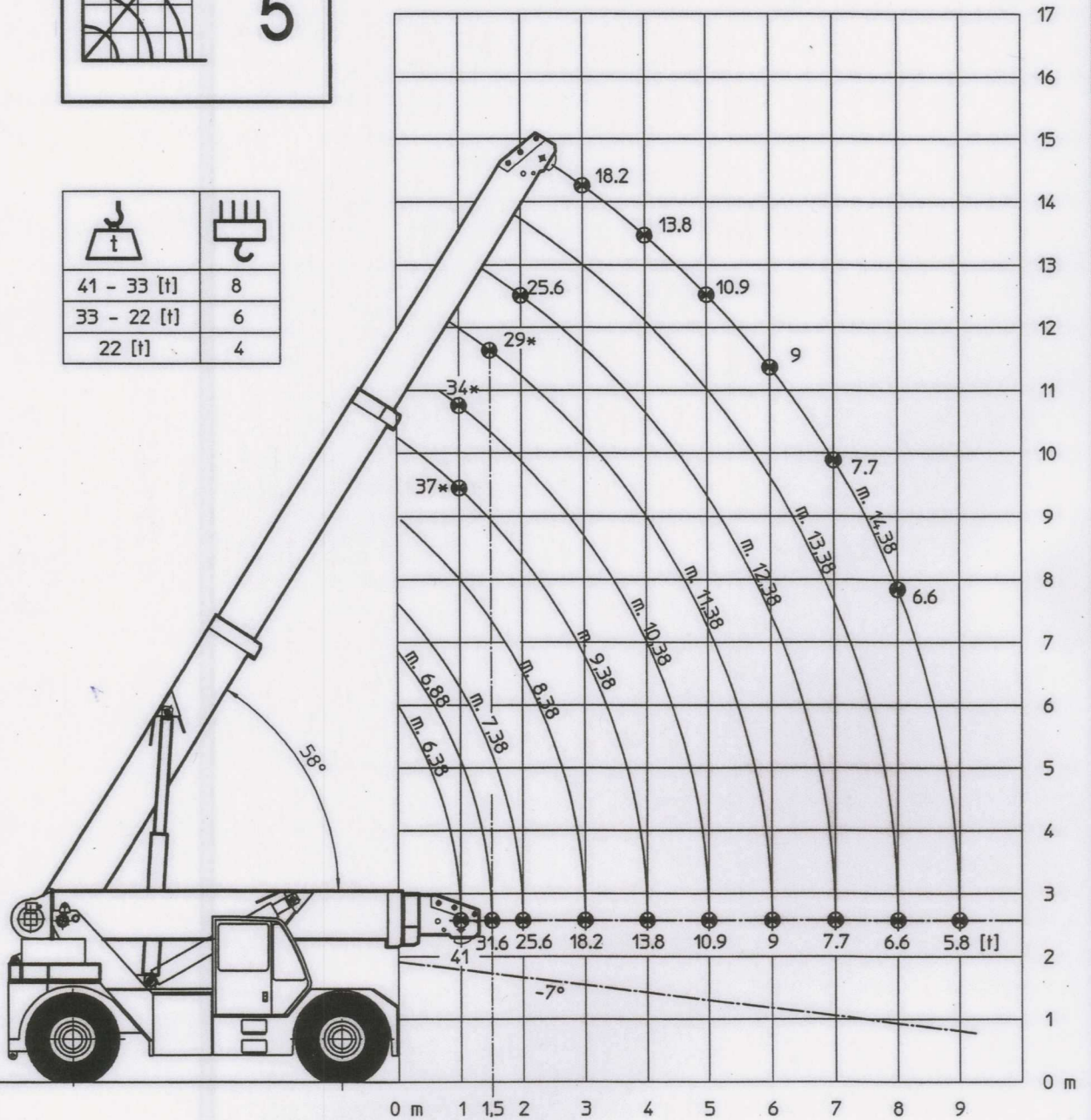

10 bar	B6		
	48 km/h		1 km/h

50/55tm

ORMIG

129284-1

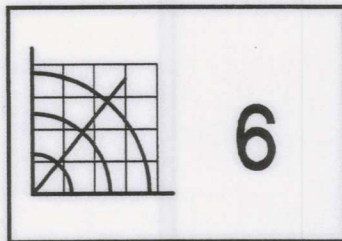
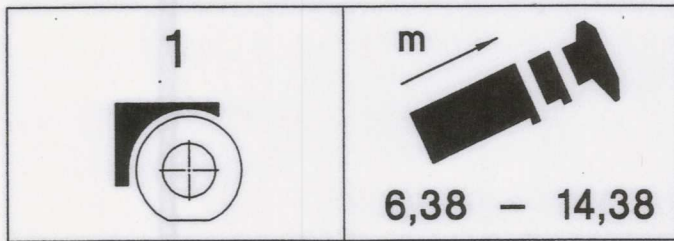

DIN

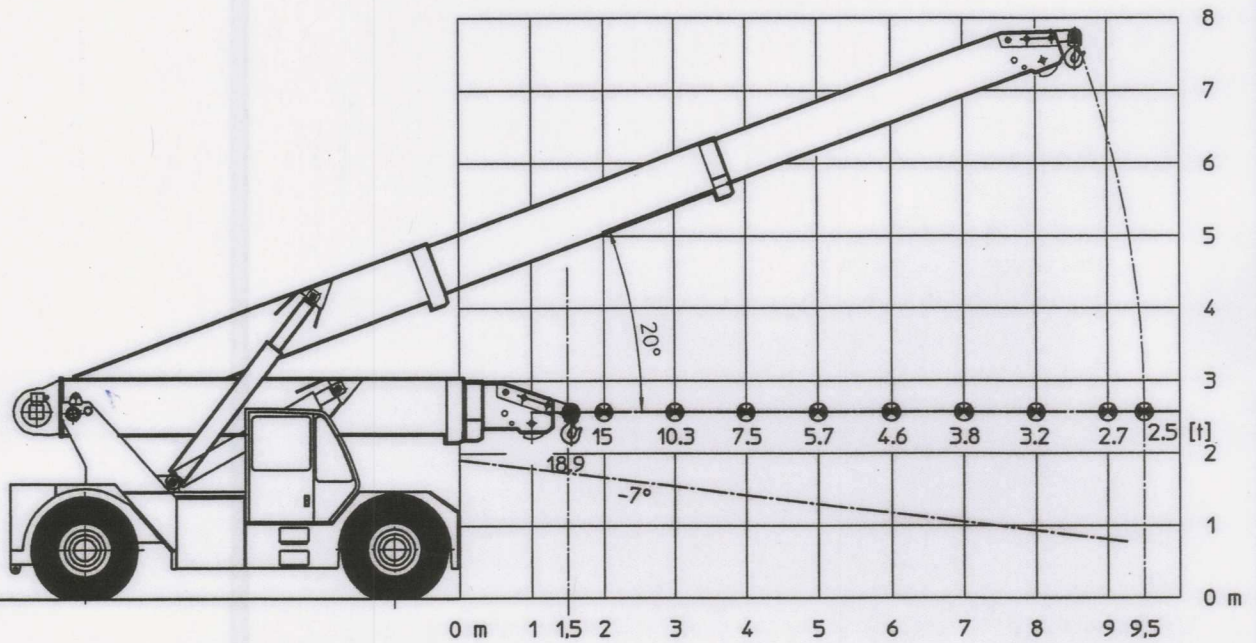
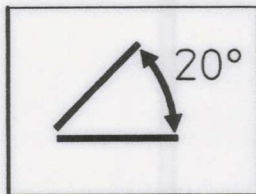

10 bar	B6		1 km/h
	48 km/h		

50/55tm

ORMIG

129285-1

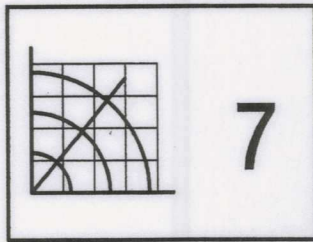
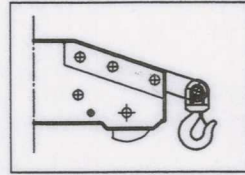
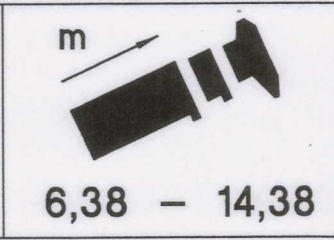
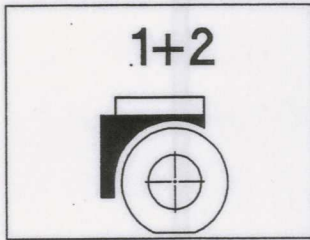

DIN

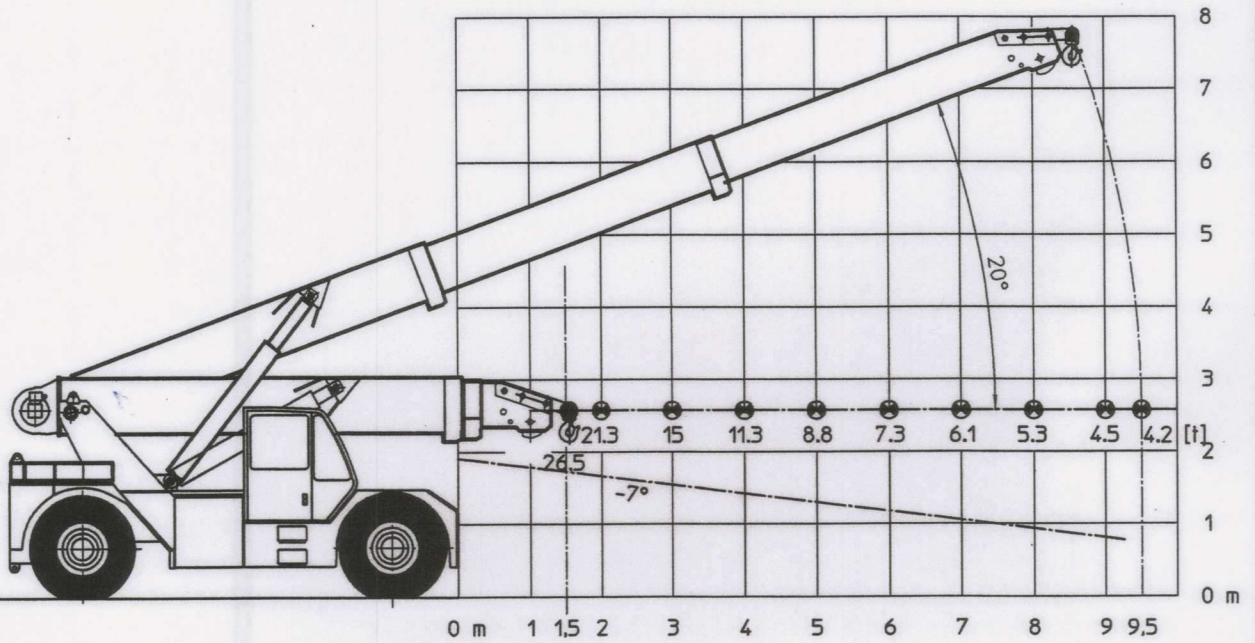
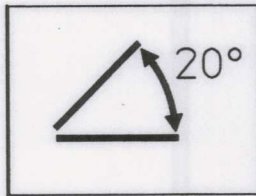

10 bar	B6		1 km/h
	48 km/h		

50/55tm

ORMIG

129286-1

1+2+3

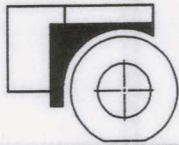

m

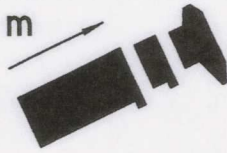

6,38 - 14,38

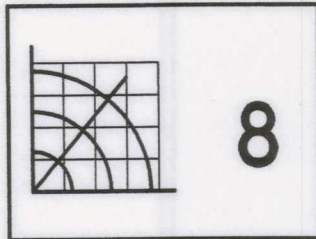
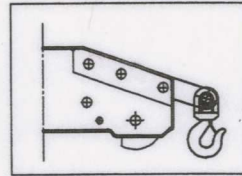

DIN

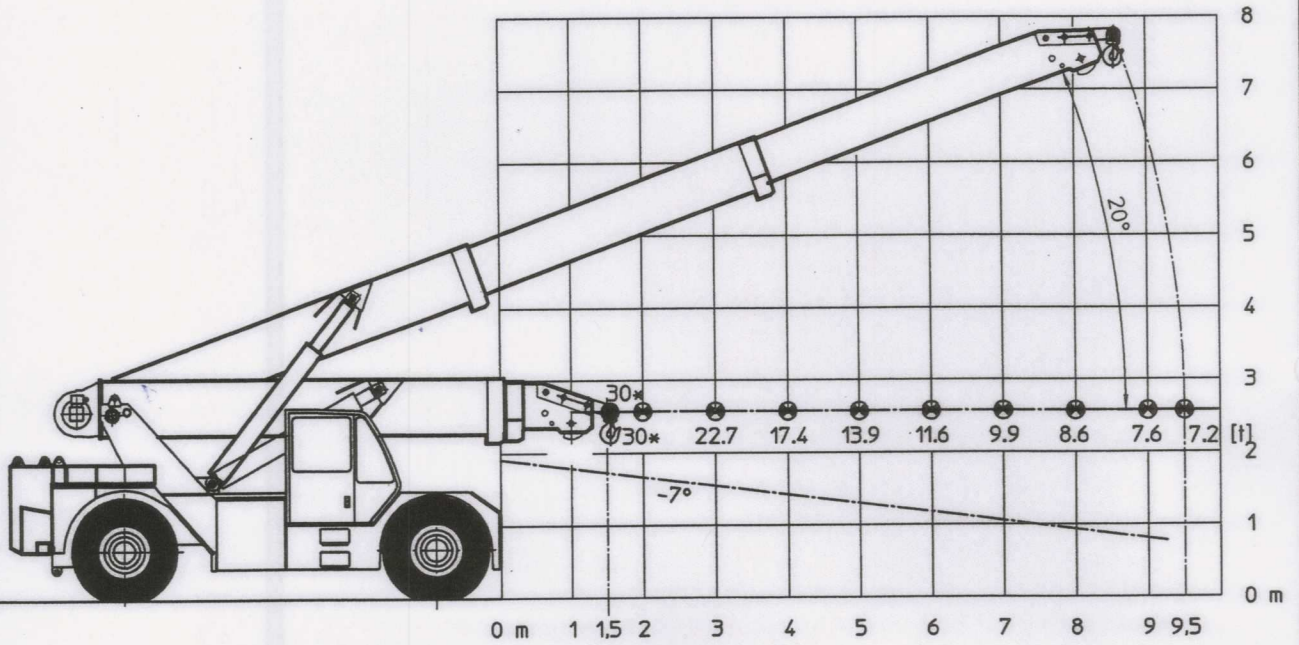
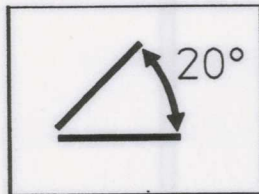

10 bar	B6	5 km/h	1 km/h

50/55tm

ORMIG

129287-1

1+2+3+4+5

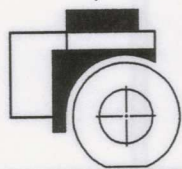

m

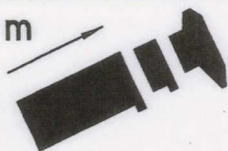

6,38 - 14,38

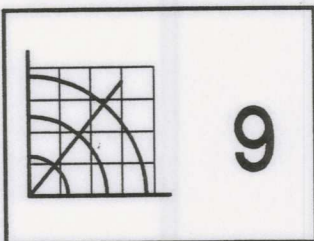
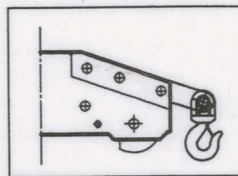

DIN

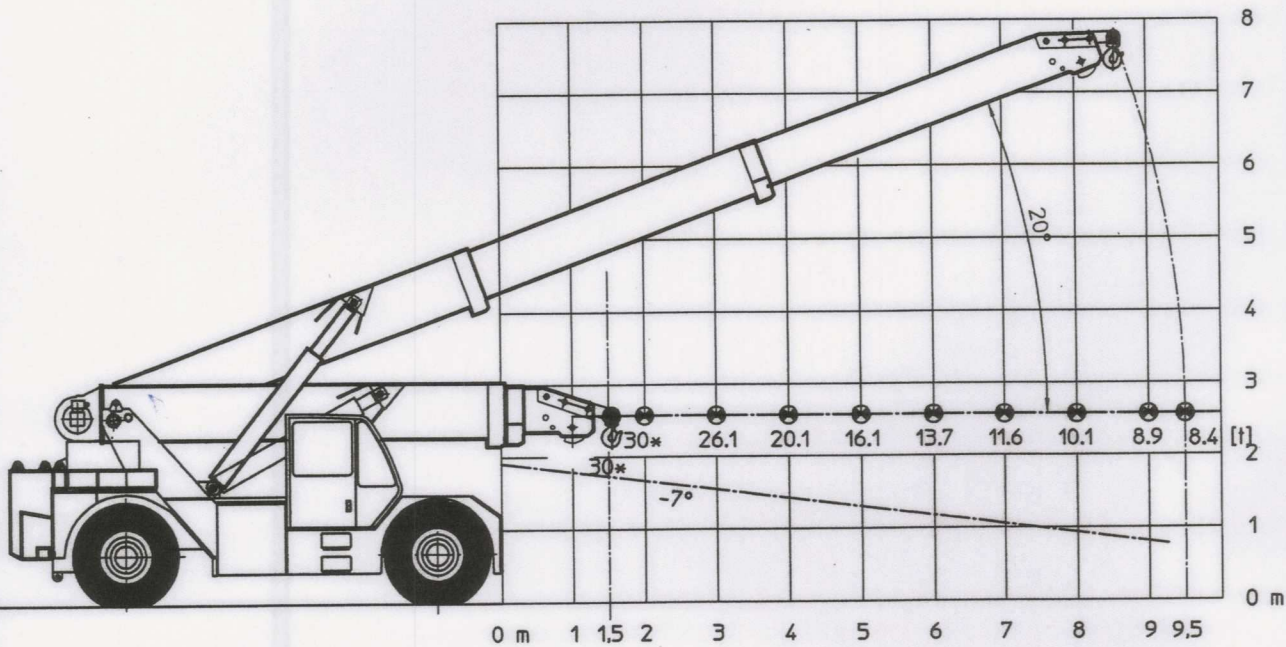
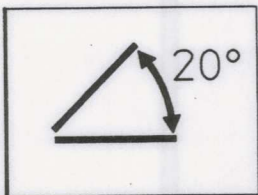

10 bar	B6	48 km/h	1 km/h

50/55tm

ORMIG

129288-1

1+2+4+5



m

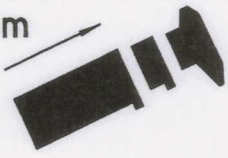

6,38 - 14,38

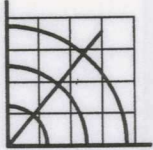
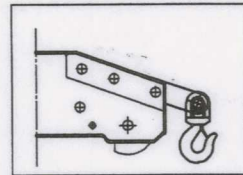

10

DIN

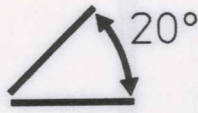

20°

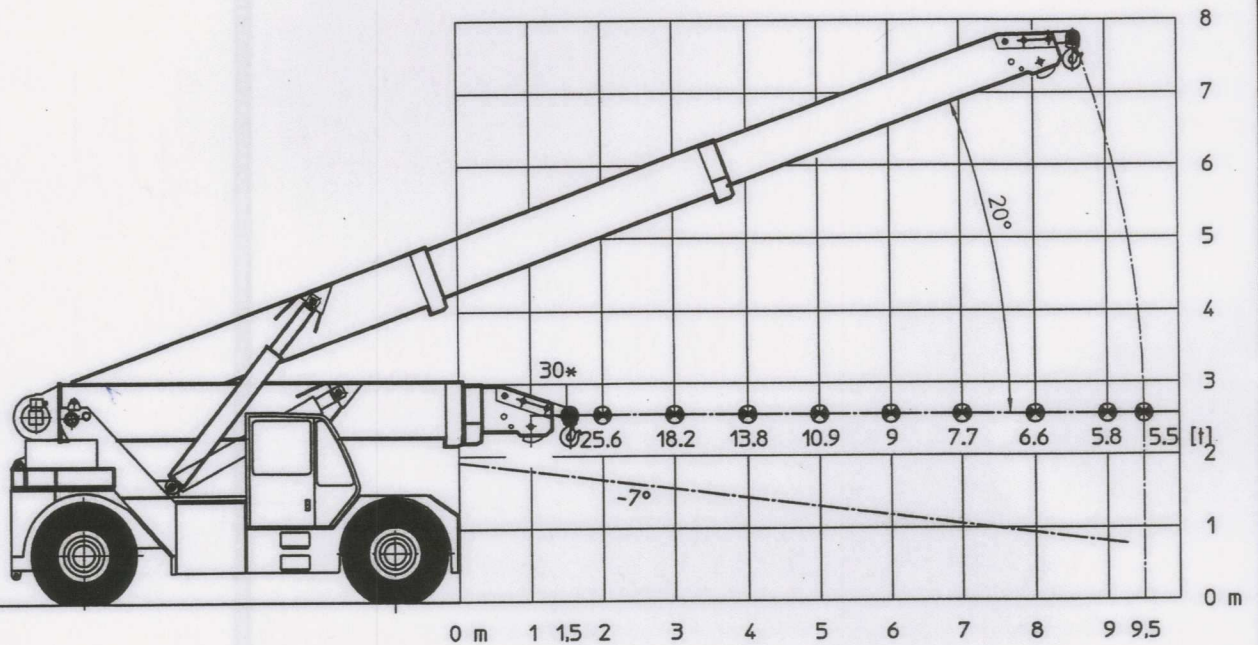

10 bar

B6

48 km/h

1 km/h



50/55tm



129289-1

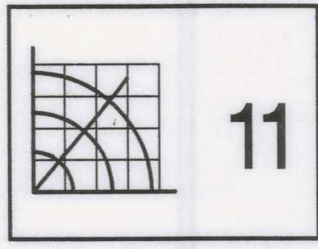
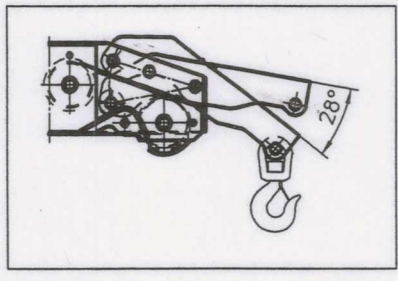
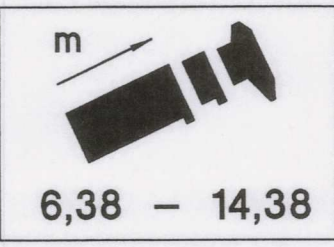
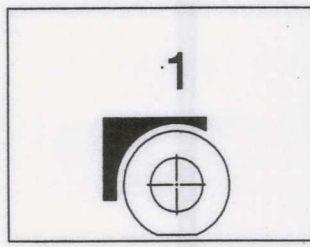

DIN

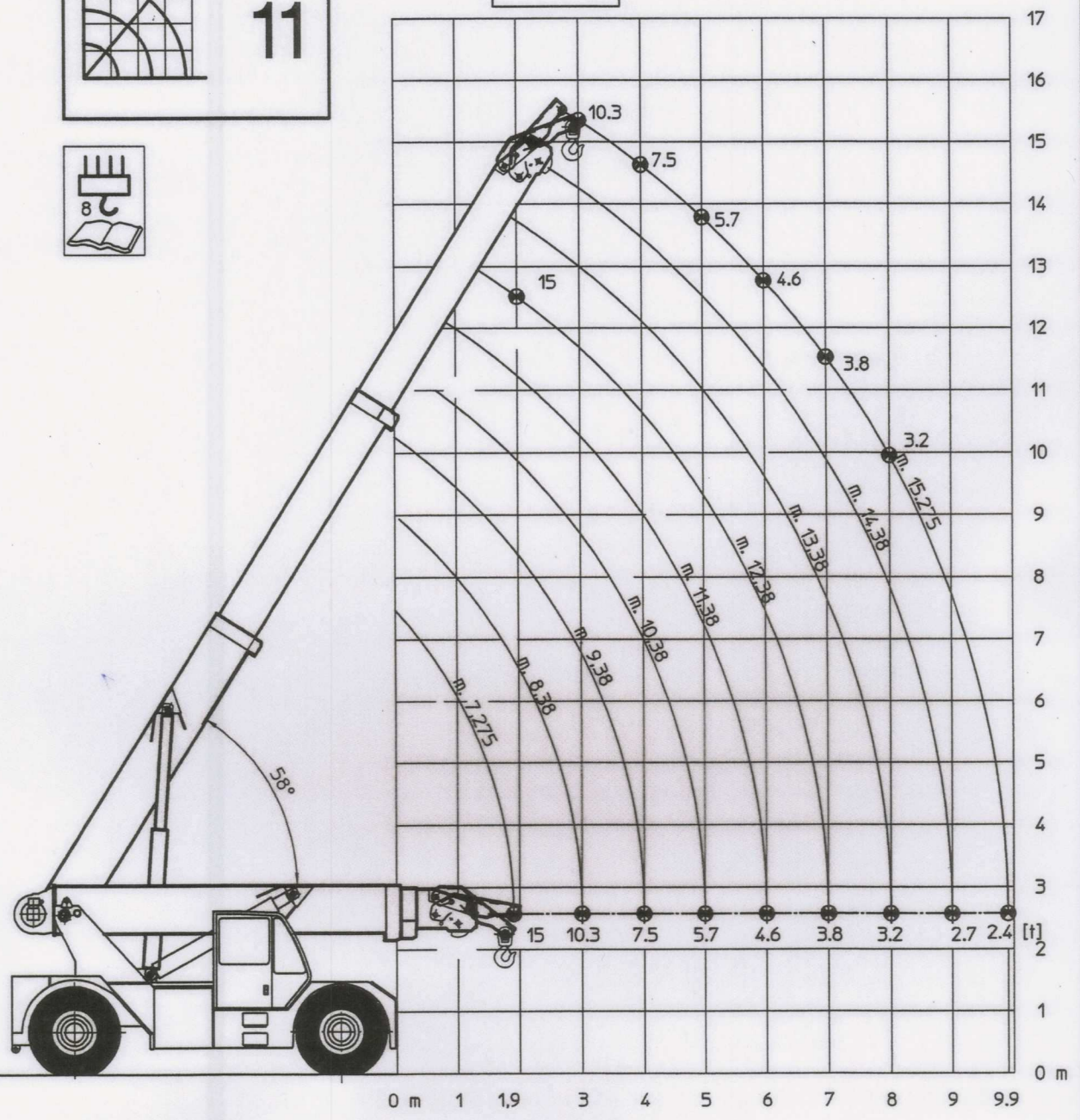

50/55tm

ORMIG

129290-1

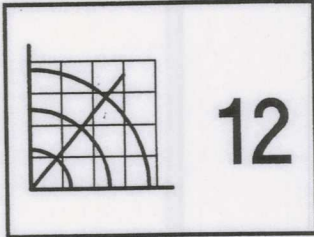
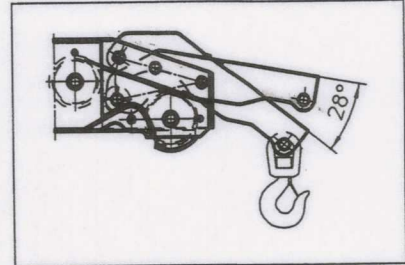
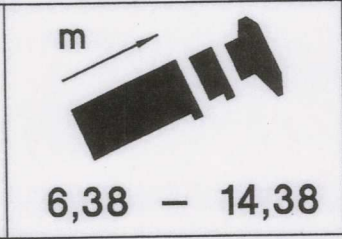
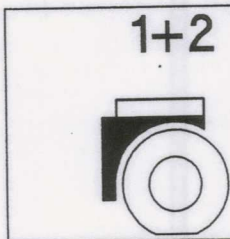

DIN

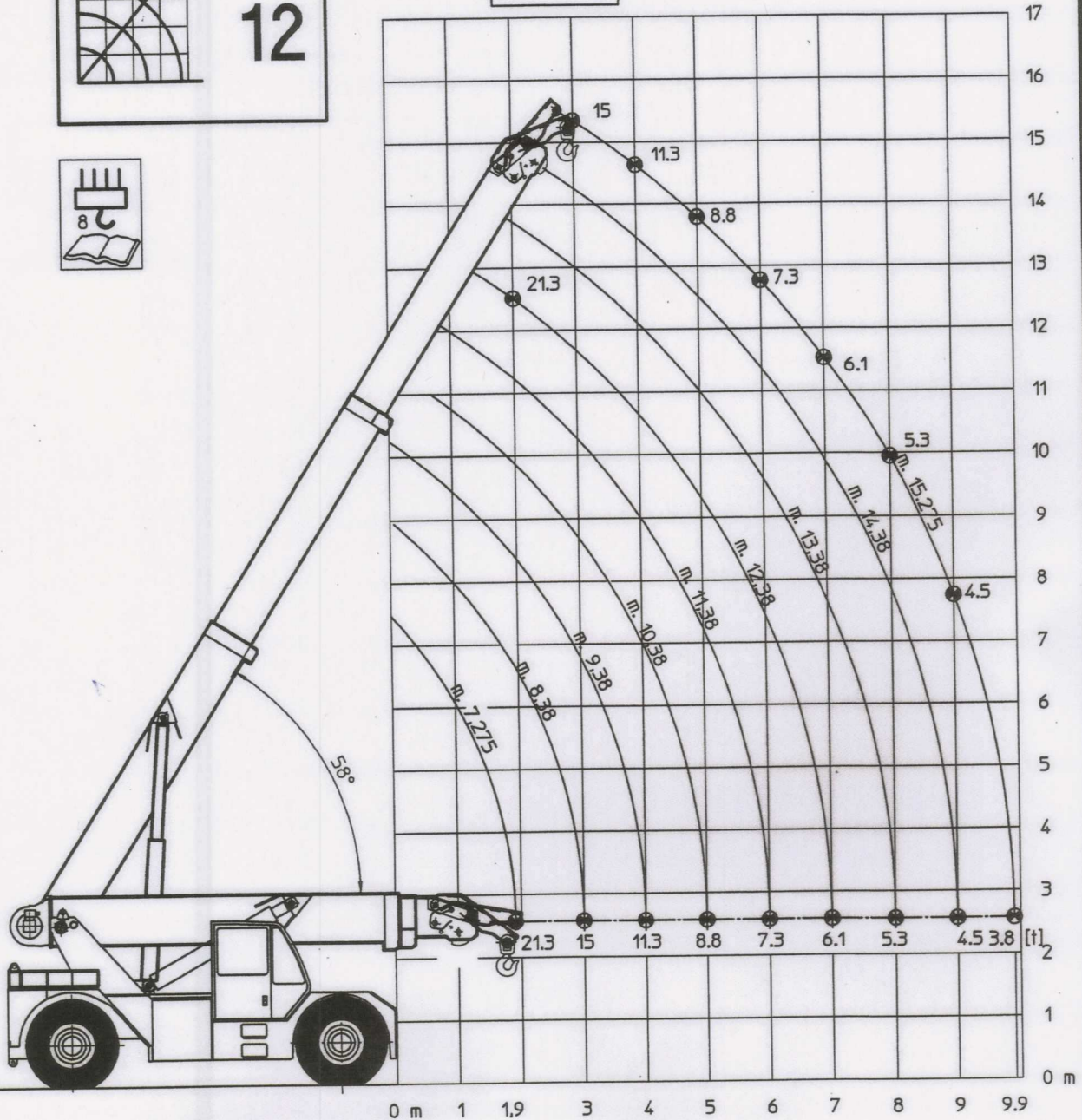

50/55tm

ORMIG

129291-1

1+2+3

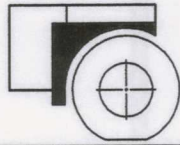

m

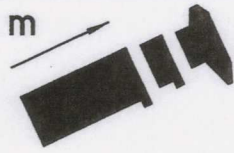

6,38 - 14,38

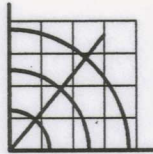
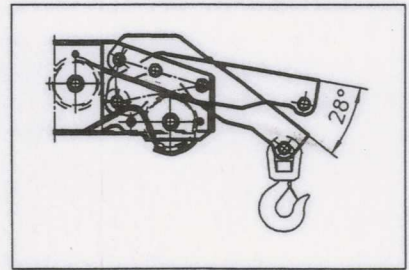

13

DIN

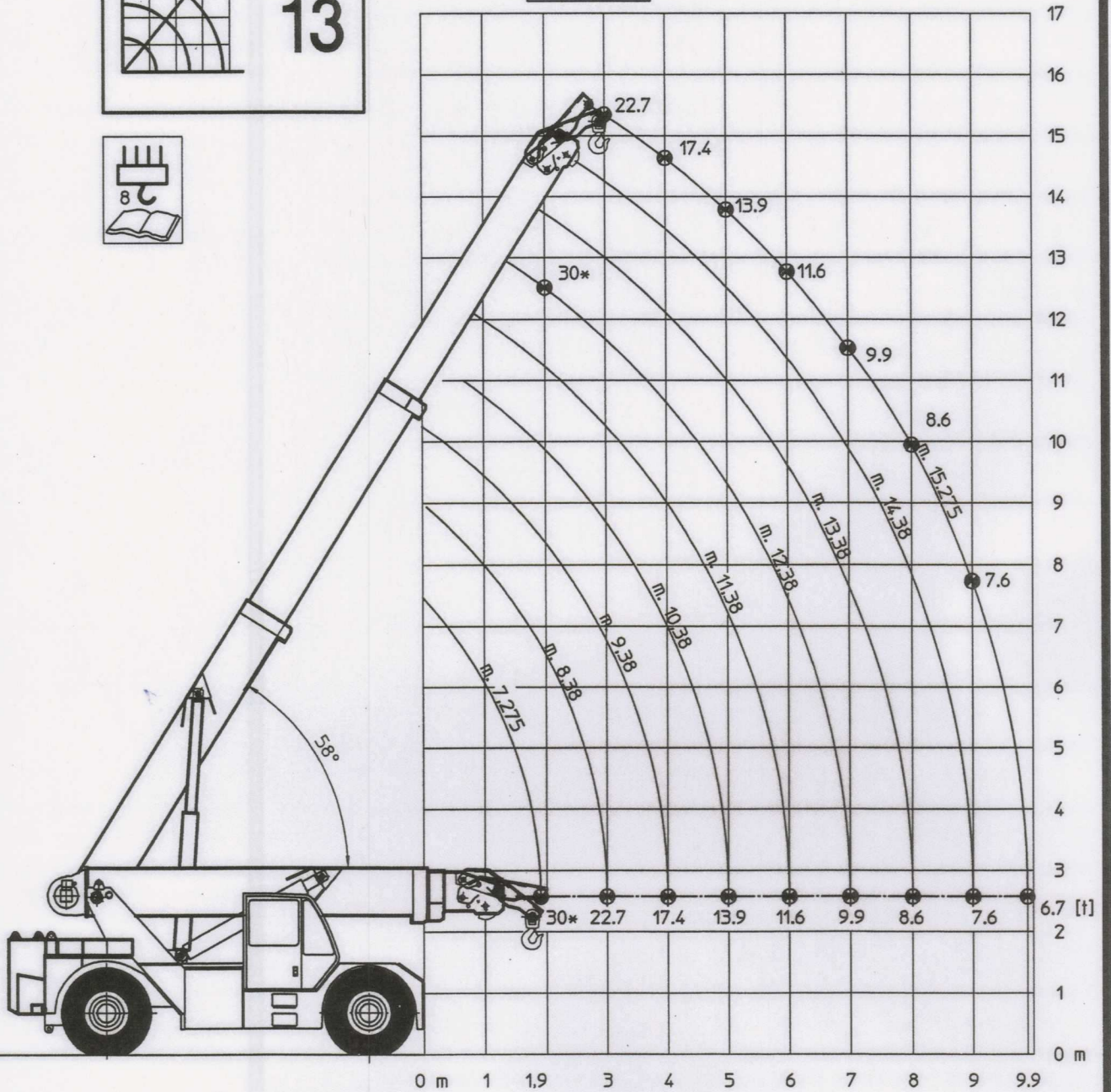

10 bar B6 48 km/h 5 km/h 1 km/h

50/55tm

ORMIG

129292-1

1+2+3+4+5

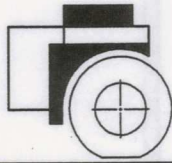

m

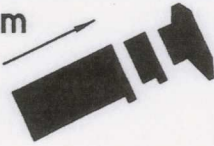

6,38 - 14,38

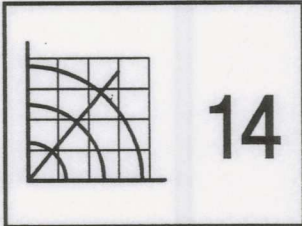
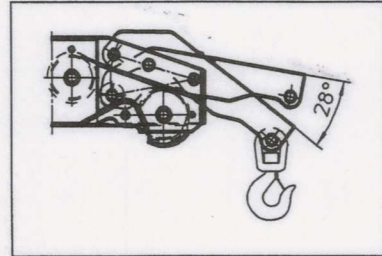

DIN

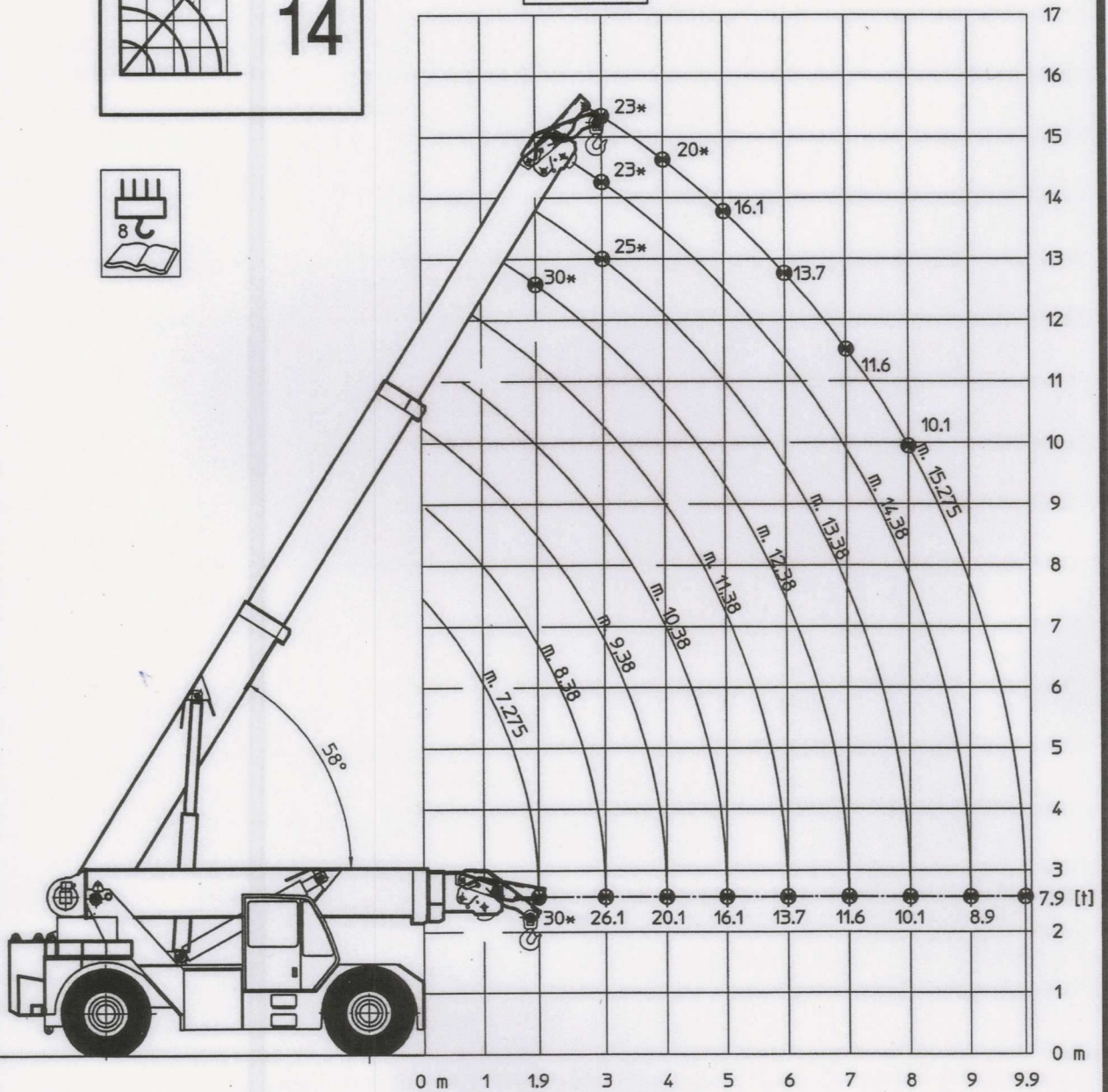

50/55tm

ORMIG

129293-1

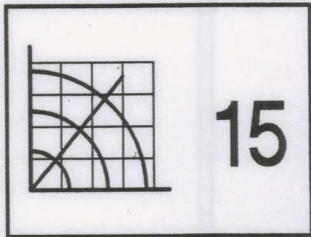
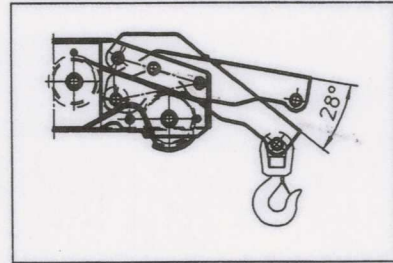
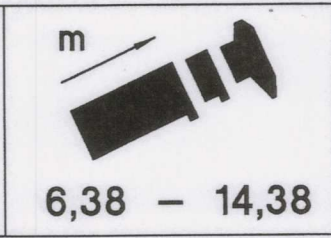
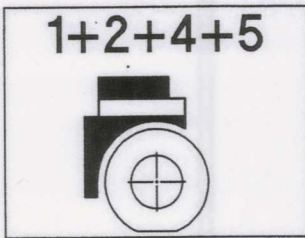

DIN

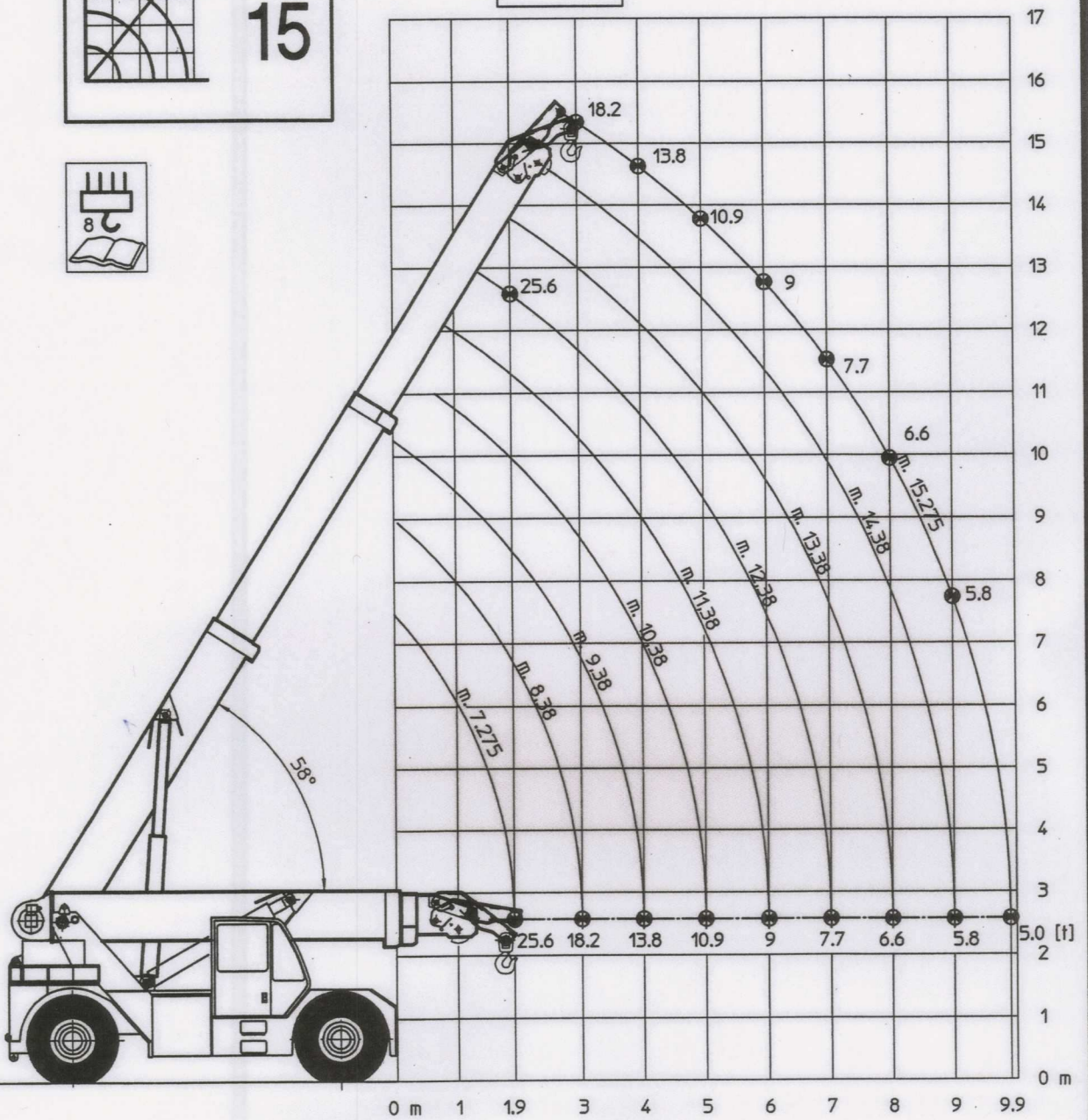

10 bar	B6		1 km/h
	48 km/h		

50/55tm

ORMIG

129294-1

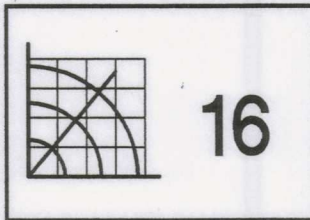
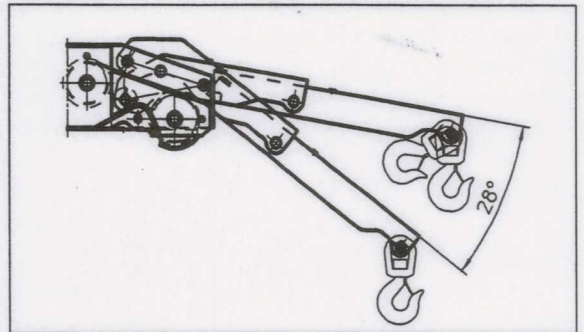
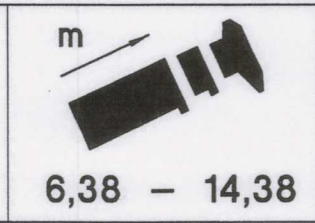
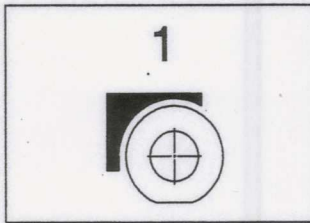

DIN

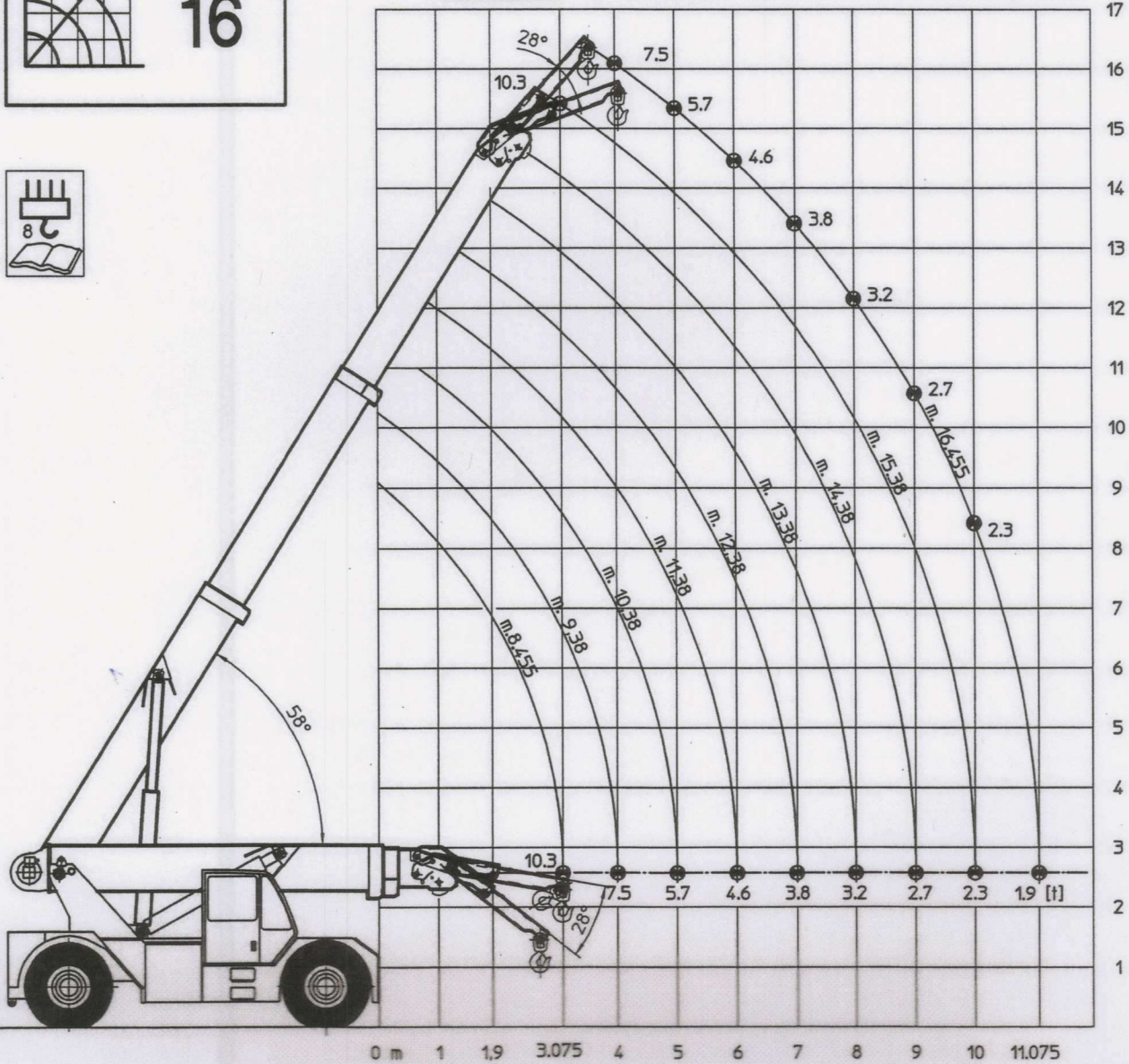

50/55tm

ORMIG

129295-1

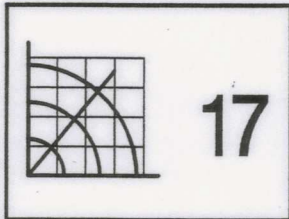
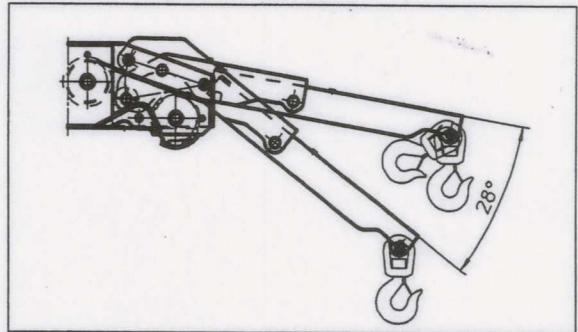
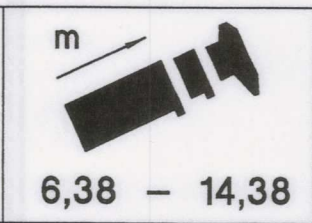
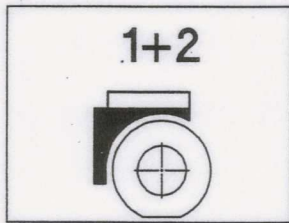

DIN

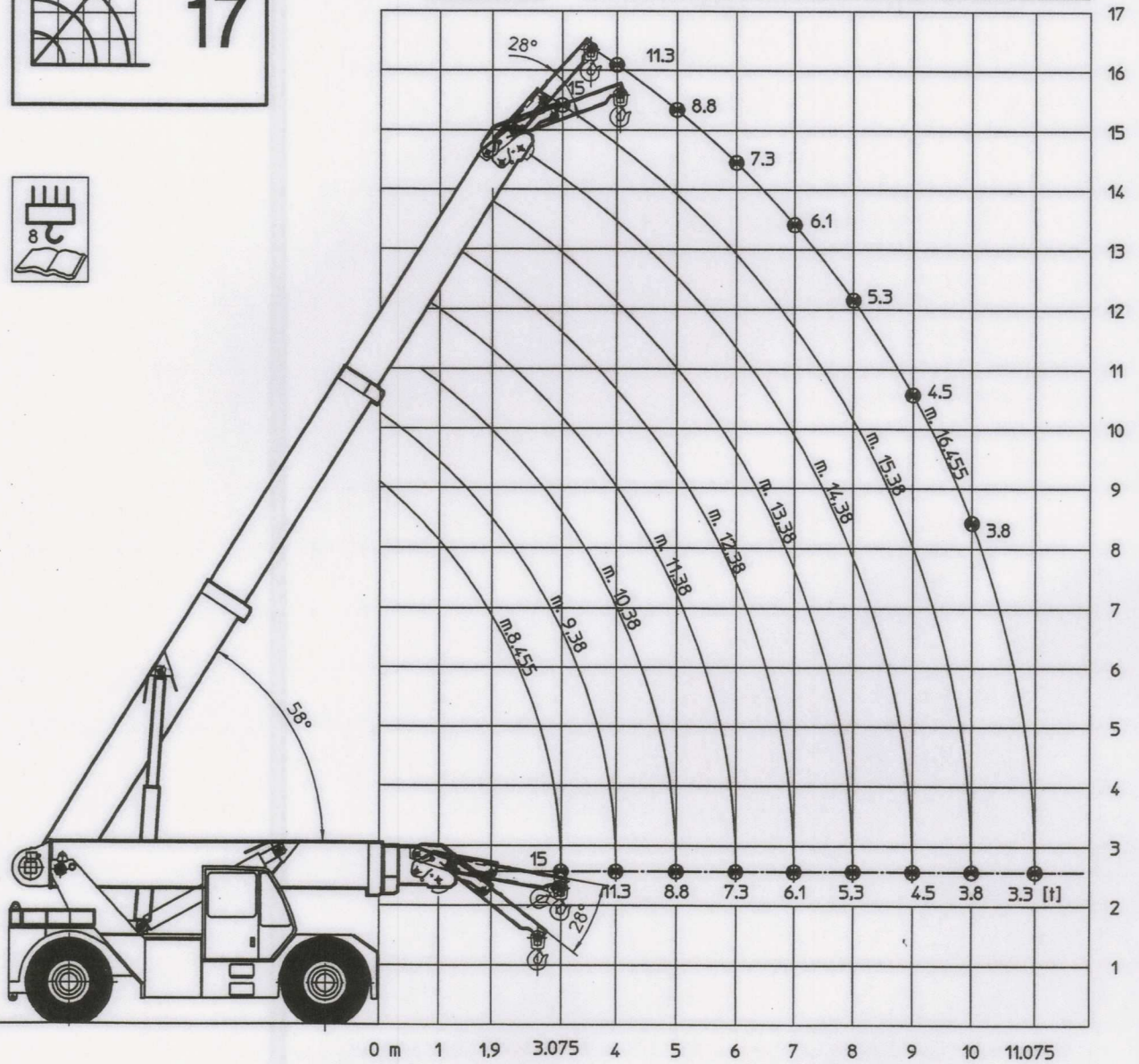

10 bar

B6

48 km/h

1 km/h

50/55tm

ORMIG

129296-1

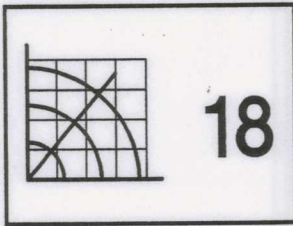
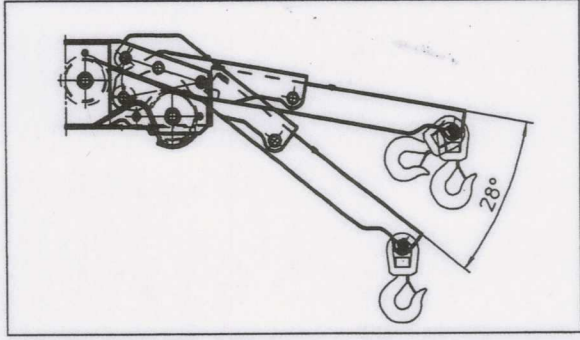
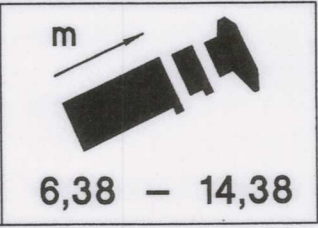
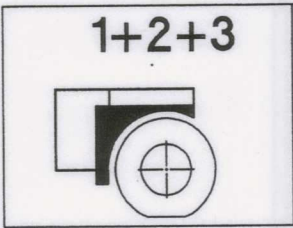

DIN

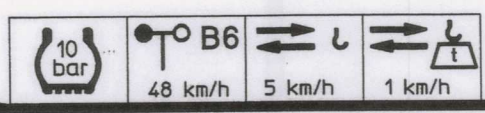
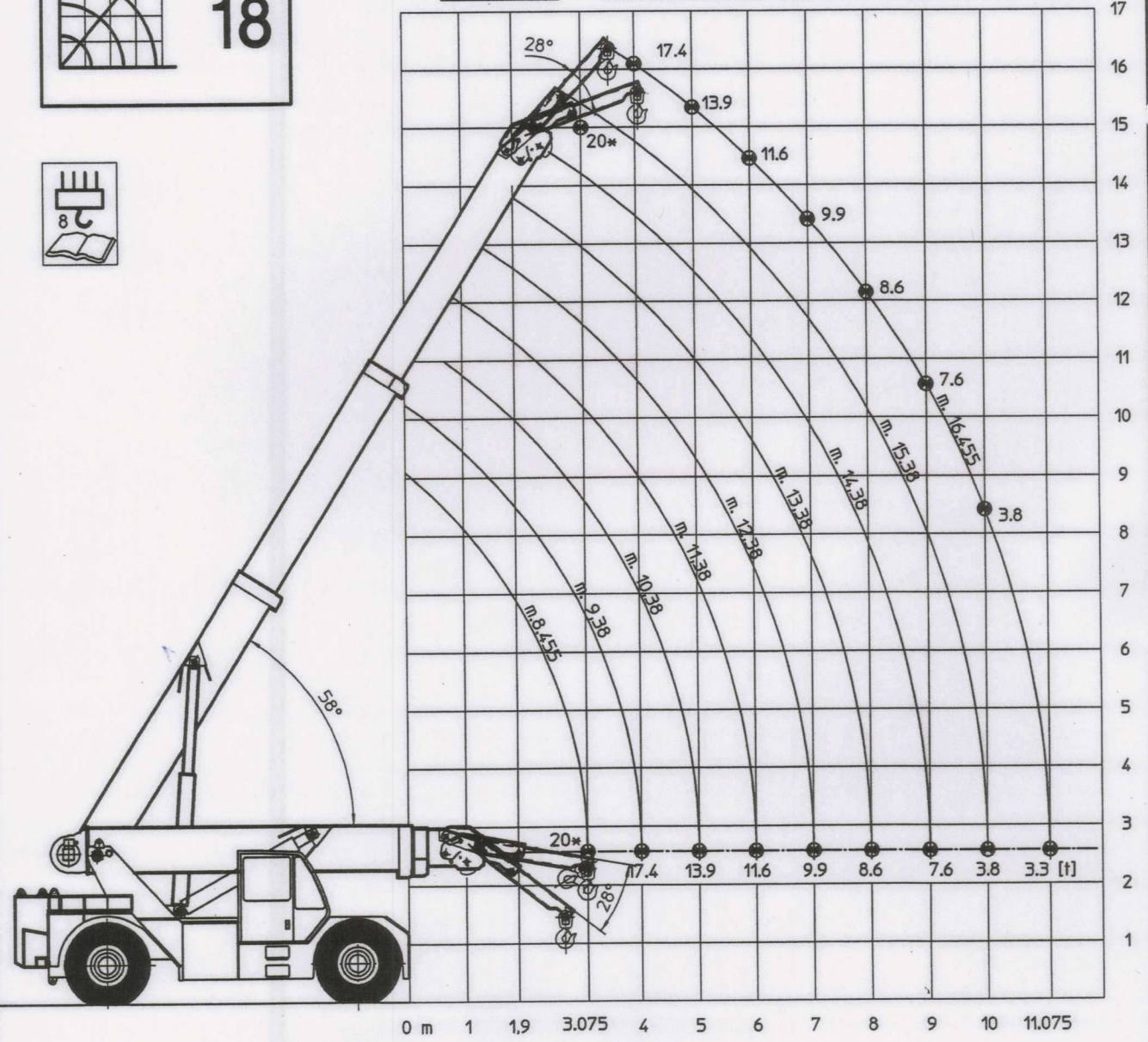

50/55tm

ORMIG

129297-1

1+2+3+4+5

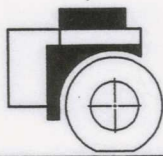

m

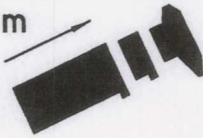

6,38 - 14,38

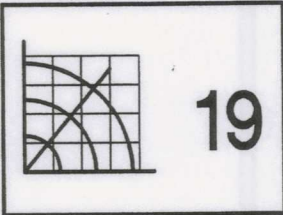
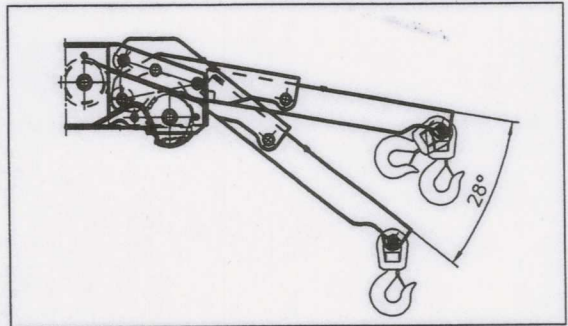

19

DIN

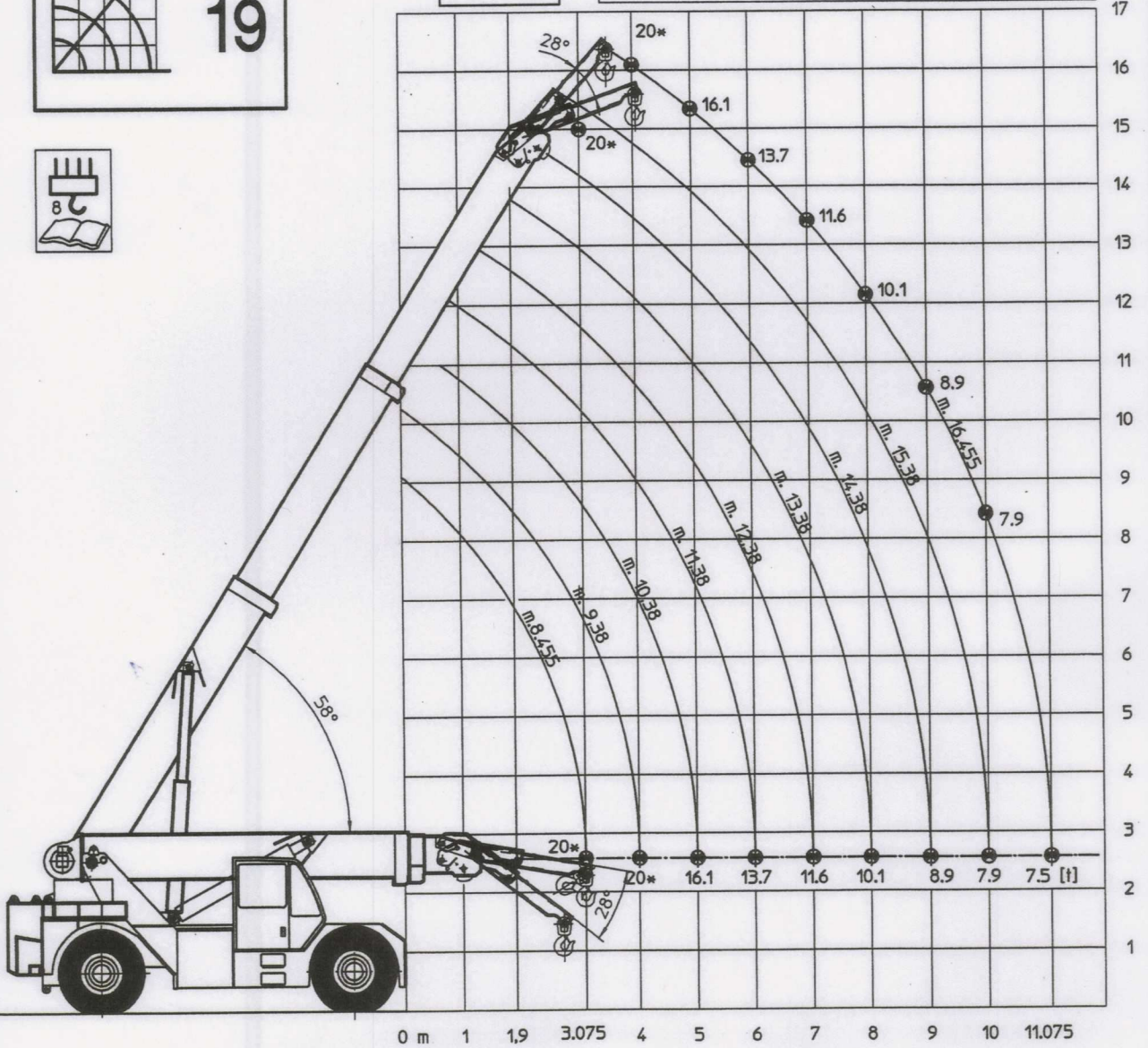

50/55tm

ORMIG

129298-1

1+2+4+5



m

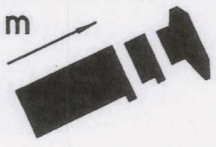

6,38 - 14,38

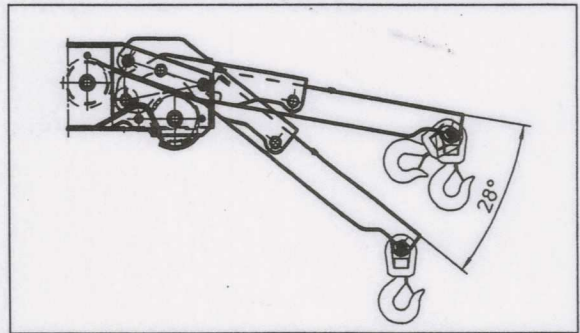
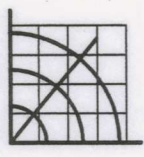
20

DIN

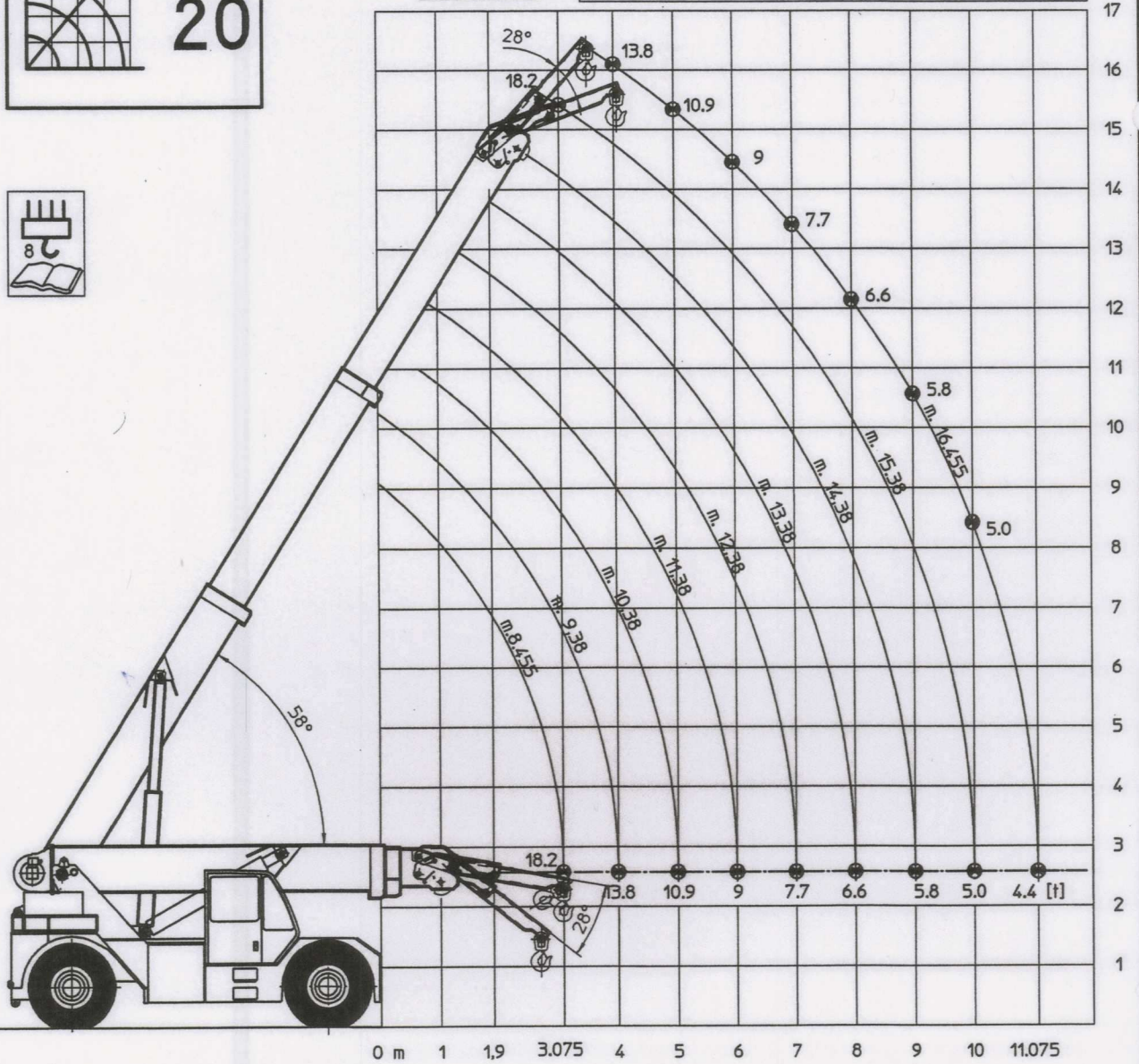

10 bar

B6

48 km/h

1 km/h