

# P&H® 430A-TC

## 35 ton Truck Crane



### BOOM

Two piece 30' (9.1 m) long, open throat lattice type tubular boom consisting of 15' (4.6 m) long tapered base section and a 15' long standard tapered tip section. All boom sections are pin connected, have a 42" x 42" (1067 mm x 1067 mm) cross section and complete with suspension cable assemblies. Sections are fabricated from tubular T-1 steel and reinforced with contour-cut tubular lacings for strongest welded joints.

**STANDARD TIP:** 15' (4.6 m) long section has 3 offset boom point sheaves 18.5" (470 mm) P.D. with roller bearings. Boom extendible to 170' (51.8 m).

**BOOM INSERT SECTION:** 10' (3.1 m) Boom insert with suspension cable assemblies, pin connections ..... optional  
 20' (6.1 m) insert ..... optional  
 30' (9.1 m) insert ..... optional

**JIB:** 20' (6.1 m) long jib, open throat lattice type, two equal tapered sections, pin connected, having a 16" x 20" (406 mm x 508 mm) cross section and with single 17.25" (438 mm) P.D. jib point sheave, compression strut and guy cable assemblies. Extendible to 40' (12.2 m). Extends reach to 193' (58.8 m). For lifts not exceeding 10,000 lb. (4536 kg) Optional.

#### JIB INSERT SECTIONS:

10' (3.1 m) jib insert with cable assemblies ..... optional

**MID-POINT SUSPENSION:** Required when boom length is 150' (45.7 m) or longer.

**BOOM HOIST REEVING:** 12 parts of 1/2" (13 mm) wire rope standard.

**BOOM BACKSTOPS:** Spring loaded type.

**WIRE ROPE GUIDE ROLLERS:** Use as required to eliminate cable interference.

#### HOOK BLOCKS:

Block Capacity	Number Sheaves	Wire Rope Size	Weight	Wire Rope to Sheave Ratio	Part No.
36,000 lbs. (16329.6 kg)	1	3/4"	350 lbs. (158.8 kg)	16.66 to 1	8U7-D6 (Standard)
60,000 lbs. (27216 kg)	2	3/4"	400 lbs. (181.4 kg)	16.66 to 1	8U7-D9 (Opt.)
70,000 lbs. (31752 kg)	3	3/4"	490 lbs. (222.3 kg)	16.66 to 1	8U7-D12 (Opt.)
10,000 lb. (4536 kg)	Weighted Hook		215 lb. (97.5 kg)	-----	8U7-D502 (Jib-Opt.)

#### SHEAVE AND DRUM TO WIRE ROPE RATIOS:

	Boom Hoist	Left Crane	Left Dragline	Left Clamshell
Sheave to Wire Rope	15 to 1	24.66 to 1	-----	24.66 to 1
Drum to Wire Rope	19 to 1	18.66 to 1	18.66 to 1	18.66 to 1
	Third	Right Crane	Right Dragline	Right Clamshell
Sheave to Wire Rope	-----	23 to 1	24.66 to 1	24.66 to 1
Drum to Wire Rope	17 to 1	18.66 to 1	18.66 to 1	18.66 to 1

### UPPERSTRUCTURE

**FRAME:** All welded frame and power box constructed of heavy steel plate. Shaft mountings are line bored to insure precise alignment of all parts. Gearing (except swing) is sealed and splash lubricated. Involute splined shafts are used, turn in roller and ball bearings. Gears and roller chains are hardened, sealed in oil bath for long, trouble free operation.

**MACHINERY CAB:** All steel construction, access panels on both sides and roof. Removable panels for main drum brake access. No lines pass through cab. Low profile, recessed center roof. Deck covered with non-skid floor plate. Deck machinery is in compact arrangement, easy to maintain and repair.

**GANTRY:** Two position folding gantry. Power raise and lowering 6 sheaves - 7.5" (191 mm) P.D.

**COUNTERWEIGHTS:** 3000 lb. (1360.8 kg) punchings, 10,000 lb. (4536 kg) cast, removable using 2 hydraulic jacks set in carrier frame.

**OPERATORS CAB:** Totally enclosed from weather. Full vision cab has safety glass throughout, sliding front window and door. Operators four-way adjustable seat, signal horn, L.H. drum turn indicator, boom angle indicator and boom hoist kick-out limit switch are standard.

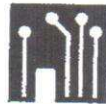

### CONTROLS:

In front of operator are foot pedals for left and right drum brakes, hand levers for swing control, left and right drum controls, boom hoist control, swing brake and engine speed control. At operators left are console mounted switches for right and left drum pawls and brake locks, master switch, engine start, starting aid and lights. Included are gauges for fuel level, engine coolant temperature, oil pressure, voltmeter, hourmeter, engine clutch pedal, trouble light receptacle and drum turn indicators (optional).

**HYDRAULIC SYSTEM:** Direct acting hydraulic system to right and left drums and boom hoist brakes and clutches. Response is instant, positive and smooth to operators touch. Fluid is stored in 1.06 quart (1 liter) reservoir.



### POWER PLANT:

ENGINE:	STANDARD	OPTIONAL
Make	Detroit Diesel	Cummins
Model	4-53N	V-378
Type	Diesel	Diesel
No. of Cylinders	4	6
Bore x Stroke, in.	3.875 x 4.5	4.625 x 3.75
	mm	(98.4 x 114.3)
Displacement, in.	212	378
	liters	6.194
Cycles	2	4
Air Induction	Roots Blower	Nat. Aspirated
Cooling	Liquid	Liquid
Starter	12 V	12 V
Alternator	12 V. - 42 A.	12 V. - 58 A.

# Specifications

**TRANSMISSION:**

Make Borg Warner  
 Model T-18  
 Type 4 Speed Manual  
 (2nd Gear Normal)

**RATINGS:**

Net HP RPM 90 @ 2200 90 @ 2700  
 (Flywheel)  
 Net HP RPM 86 @ 665 86 @ 667  
 (Trans. Output Shaft)  
 Altitude Range, Ft. 0-6500 0-10000  
 (M) (1981.2) (3048.)  
 Temp. Range in F. -20° to 110° -20° to 110°  
 (C.) (-28° to 43°) (-28° to 43°)

**Input disconnect clutch** — Transmission - single plate dry type mechanically engaged. 12" dia. (305 mm).

**Throttle** — Twist grip control on swing lever and foot pedal (standard).

**Fuel tank capacity** — 40 gallons (151.4 liters).

		Detroit Diesel	Cummins
Lube Oil Capacity	Engine:	12 qts. (11.36 liters)	5.5 qts. (5.2 liters)
	Filter:	2.5 qts. (2.37 liters)	
Coolant Capacity	Engine:	2.25 gal. (8.52 liters)	2.5 gal. (9.46 liters)
	Radiator:	3.125 gal. (11.83 liters)	3 gal. (11.36 liters)
Air Cleaner		Donaldson oil type	Farr, 2-stage dry type
Lube Oil Filter	Full-Flow By-Pass	Replaceable	Replaceable
Fuel Filter	Primary Secondary	Replaceable	2-bowl filter w/o strainer

**Starting aid** — Required below 14° F. (-10° C.) ether-measured shot (optional).

**Battery** — 12 volt H.D. 215 Amp. hours @ 20 hour rate.



**LOAD DRUMS:**

**RIGHT DRUM:**

CRANE, CLAMSHELL & DRAGLINE: 14" (356 mm) P.D. x 10.5" (267 mm) long. Smooth drum.

**LEFT DRUM:**

CRANE AND CLAMSHELL: 14" (356 mm) P.D. x 10.5" (267 mm) long. Smooth drum.

DRAGLINE: 14" (356 mm) P.D. x 10.5" (267 mm) long. Grooved drum. Total wire rope length of 3/4" (19 mm) dia. wire rope is 528 ft. (160.9 m) storage or 444.3 ft. (135.4 m) working length.

	Transmission Range	1st Gear	2nd Gear (Normal)	3rd Gear	4th Gear
HOISTING Right & Left	Gear Ratio	6.32 to 1	3.09 to 1	1.69 to 1	1.00 to 1
	Line Speed fpm m/min.	90.7 (27.7)	171 (52.2)	317 (96.6)	530 (161.5)
	Line Pull lb. kg	28267 (12822)	15032 (6818)	8133 (3689)	4865 (2207)
LOWERING Right & Left	Line Speed fpm m/min.	40.9 (12.5)	76.8 (23.4)	141.9 (43.3)	237.3 (72.3)

**CLUTCH:** (Right and Left) — 23" (584 mm) dia. x 3" (76 mm) wide, band type, internal expanding.



**BRAKE:** (Right and Left) — 28" (711 mm) dia. x 3.5" (89 mm) wide, band type, external contracting. Hydraulic set, with external ratchet for locking drum.



**POWER CONTROLLED LOAD LOWERING:** Safe lowering through reverse planetary gearing in drum. External brake on drum engages planetary gears. (Optional for either drum).



**THIRD DRUM:**

Mounts on extension of boom hoist shaft. Does not interfere with any machine function.

**DRUM:** 8.5" (216 mm) P.D. x 5.75" (146 mm) long. Total wire rope length of 1/2" (13 mm) wire rope is 256.3 ft. (78 m) storage or 214.9 ft. (65.5 m) working length.

Transmission Range	1st Gear	2nd Gear (Normal)	3rd Gear	4th Gear
Gear Ratio	6.32 to 1	3.09 to 1	1.69 to 1	1.00 to 1
Line Speed	102 fpm (31.1 mpm)	191.7 fpm (58.4 mpm)	354 fpm (108 mpm)	592.5 fpm (180.6 mpm)
Line Pull	8777.5 lb. (3981.4 kg)	4667.7 lb. (2117 kg)	2525.4 lb. (1145.5 kg)	1510.6 lb. (685.2 kg)



**CLUTCH:** 16" (406 mm) dia. x 2.5" (64 mm) wide, band type, internal expanding.



**BRAKE:** 17.25" (438 mm) dia. x 2.5" (64 mm) wide, band type, external contracting "full wrap" design.



**BOOM HOIST:**

Independent planetary gear type with external ratchets and automatic brakes provides for raising and lowering boom under power and locking boom.

**DRUM:** 9.5" (241 mm) P.D. x 5.6875" (144.5 mm) long. Total wire rope length per drum for 1/2" (13 mm) wire rope is 275 ft. (84 m) storage or 230.7 ft. (70.4 m) working length.

Transmission Range	1st Gear	2nd Gear (Normal)	3rd Gear	4th Gear
Gear Ratio	6.32 to 1	3.09 to 1	1.69 to 1	1.00 to 1
HOISTING Line Speed	113.9 fpm (34.7 mpm)	214.2 fpm (65.3 mpm)	396.0 fpm (120.7 mpm)	662 fpm (201.8 mpm)
Line Pull	12288.5 lb. (5574 kg)	6534.7 lb. (2964.1 kg)	3535.5 lb. (1604 kg)	2114.8 lb. (959.3 kg)
LOWERING Line Speed	54.4 fpm (16.6 mpm)	102.3 fpm (31.2 mpm)	189.1 fpm (57.6 mpm)	316.1 fpm (96.3 mpm)



**CLUTCH SIZE:** 16" (406 mm) dia. x 2.5" (64 mm) wide, band type, internal expanding.



**BRAKE SIZE:** 18" (457 mm) dia. x 2.5" (64 mm) wide, band type, external contracting "full wrap" design.



**SWING:**



**CLUTCH:** (2) - 21" (533 mm) dia. x 4.5" (114 mm) wide, shoe type, internal expanding.



**BRAKE:** 13" (330 mm) dia. "V" groove. Hydraulic release, spring set.

**SWING GEAR:** 121 internal cut teeth. 48.4" (1016 mm) P.D.

Transmission Range	1st Gear	2nd Gear (Normal)	3rd Gear	4th Gear
Gear Ratio	6.32 to 1	3.09 to 1	1.69 to 1	1.00 to 1
Swing Speed	2.21 RPM	4.17 RPM	9.04 RPM	12.88 RPM

**FASTENING TO LOWER:** Roller bearing "Swing Circle"® 60.125" (1527 mm) dia.

### CARRIER: 8 WHEELS, 4 WHEEL DRIVE, 12 TIRES

**FRAME:** Front section is fabricated from 15" — 50 lb. channel. Rear section is crossbraced and reinforced. Front bumper is formed from 0.38 plate. High strength low alloy steel used extensively. Tow loops front and rear.

**BODY:** Cab, engine hood, front and side panels, front skirts, equipment boxes and dirt shields formed from sheet steel. Front and rear fenders, transmission cover, body floor plate, running boards, battery box and cover have non-skid material applied to upper surfaces.

**CAB:** 32 inch (813 mm) wide one-man cab offset to left side of engine compartment, all windows are safety glass, electric windshield wiper, removable dash panel (with speedometer, air pressure gage, voltmeter, coolant temperature gage, engine oil pressure gage, fuel level gage and switches), air horn, dome light, seat assembly and West Coast mirrors. Crank down door window and slide-by right side windows. Air vent on left side.

**LIGHTING:** Two headlights with foot operated dimmer switch. Stop, tail, directional, clearance and rear license plate lights. In-cab dome light, illuminated gages, indicator lights for hi-beam, directional, emergency flasher and low air pressure warning.



**OUTRIGGER BOXES:** Four (4) fabricated independent boxes of high strength low alloy steel plate. Front and rear boxes are pin connected and removable.

**OUTRIGGER BEAMS:** Four (4) fabricated reinforced box section beams of high strength low alloy steel plate. Beams telescope to fully extended position of 103 in. (2616 mm) from longitudinal center line of carrier to center line of jackscrew.

**HYDRAULIC OUTRIGGER ASSEMBLY (standard):** Eight (8) double acting hydraulic cylinders provide independent horizontal and vertical movement of each beam. The outriggers are controlled by electric solenoid actuated directional control valves operated from two control panels. Each panel controls the outriggers on control box side only.

**FLOATS:** Four (4) aluminum floats 20.75 x 20.75 in. (527 mm x 527 mm).



### POWER PLANT:

<b>ENGINE:</b>	STANDARD
Make	Detroit Diesel
Model	6V-53T
Type	Diesel
No. of Cylinders	6
Bore x Stroke, In.	3.875 x 4.50
mm	(99 x 114)
Displacement, In.	318
liters	(5.2)
Cycles	2
Air Induction	Turbocharged
Cooling	Liquid
Starter	12 volt
Charging	12 v. - 62 amp
Compressor, Air	12 CFM
Governor, Air	105 to 120 PSI
Horsepower, Gross	235 HP @ 2600 RPM

Altitude Range	0-3000
In Ft. (m)	(0-914)
Temp. Range in F. (c.)	-20° to 110° (-28° to 43°)

### TRANSMISSION

Make	Eaton-Fuller
Model	RTO-613
Type	13 speeds fwd., 3 reverse

**Clutch —** Lipe-Rollway 14-2 DLB.

**Fuel tank capacity —** 75 gallons (284 liters). Meets FHWA requirements.

**RADIATOR:** Vertical tube and fin type core, rubber mounted thermostat temperature control. Dearthation baffle in top of tank.

**Air cleaner —** Farr dry type.

**Starting aid —** Required below 14° F. (-10° C.) ether-measured shot (optional).

**Batteries —** (1) - 12 volt H.D. rated, 215 amp hours @ 20 hour rate.

**PROP. SHAFTS:** Front and intermediate prop. shafts — Spicer 1710 series U-joint. Interaxle — Spicer 1610 series U-joint.

**SUSPENSION: FRONT & REAR —** Unsprung box section bogie with torque rods. Self-aligning bearings on both ends of bogie beams.

**TIRES AND RIMS:** Std. — Twelve (12) 11.00 - 20/F load range (12-PR) non-directional tires. 20 x 8.0 - 5 disc wheels with 6.88 offset. Opt. — 12.00 - 20/G load range (14 PR) non-directional tires.

**STEERING:** Ross worm and roller steering gear 32.5 to 1 ratio. 21 inch (533 mm) diameter steering wheel. Garrison power assist.

**FRONT AXLES:** Rockwell FF-931 series in tandem. 67.5" (1715 mm) king pin centers. 80.2" (2037 mm) track with 6.88 offset wheels.

**REAR AXLES:** Rockwell SUD-A top mounted double reduction axles in tandem. 80.2 inch (2037 mm) track, 9:1 ratio. Interaxle, differential is an optional feature.



**BRAKES: SERVICE —** Dual air brake circuit with front and rear brakes on separate circuits. Front linings: 15 in. (381 mm) dia. by 5 in. (127 mm) wide (314 sq. in. (202,580 mm) total front lining area). 12 in.2 x 10° air chambers. Rear linings: 16.5 in. (419 mm) dia. by 7 in. (178 mm) wide (920 sq. in. (593,547 mm) total rear lining area). 30 sq. in. air chambers. Total brake lining area 1234 sq. in. (796,127 mm).

**EMERGENCY/PARKING —** Air release. Spring set brake chambers on all rear wheels controlled from cab. Separate reservoir for emergency release of spring set brakes.

**TOOL KIT:** Tire inflation hose, two (2) manual hydraulic jacks.

**OPTIONS — LOWER:** Fire extinguisher (1A, 10BC), front "fifth" jack float for 360° operation, ether starting aid, boom rack, 4100 lbs. (1860 kg.) front bumper counterweight, interaxle differential, on/off highway tires, heater and defroster fan, low profile floats, high water temp/low oil pressure warning system, Bostrom T-bar seat in carrier, windshield washer.

**OPTIONS — UPPER:** Winter fan for engine, heater and defroster, remote control of outriggers, planetary power load lowering for drums, drum turn indicators, fire extinguisher (1A, 10BC), windshield wiper, counterweight removal assembly, 10 KW magnet generator V-belt driven from PTO, 2.5 KW light plant driven by Kohler gas engine.

### PERFORMANCE:

#### (Based on Detroit Diesel 6V-53T Engine)

**ON HIGHWAY:** 13 forward speeds, 3 reverse speeds. Performance in highest and lowest gear based on engine @ full load rpm and 66,000# (29,938 kg) GVW. (Class I, good surface road).

Lowest gear: 4.3 MPH (6.9 km/h) to 19 percent grade.

Highest gear: 41.3 MPH (66.5 km/h) to 0.4 percent grade.

**OFF HIGHWAY:** 13 forward speeds, 3 reverse speeds. Performance in lowest gear ratio based on engine @ max. torque rpm and 66,000# GVW. (Class II road). 1.2 MPH (1.8 FPS) (1.9 km/h) to 30.0 percent grade.

**WEIGHTS:**

Carrier — Including turret, hydraulic outriggers, floats, roller circle and standard tires — 34,560 lbs. (15676 kg)

Upper machine — 21874 lb. (9922 kg)

Gantry — 638 lbs. (289.4 kg)

Counterweight —

Underslung — 10,140 lb. (4599.5 kg)

Punchings — 3,000 lb. (1360.8 kg)

Boom:

Base — 720 lbs. (326.6 kg)

Inserts — 10 ft. (3 m) — 460 lbs. (208.7 kg)

20 ft. (6.1 m) — 700 lbs. (317.5 kg)

30 ft. (9.1 m) — 890 lbs. (403.7 kg)

Tip — 1539 lbs. (698.1 kg)

Jib:

Base — 260 lbs. (117.9 kg)

Inserts — 10 ft. (3 m) — 220 lbs. (99.8 kg)

Tip — 380 lbs. (172.4 kg)

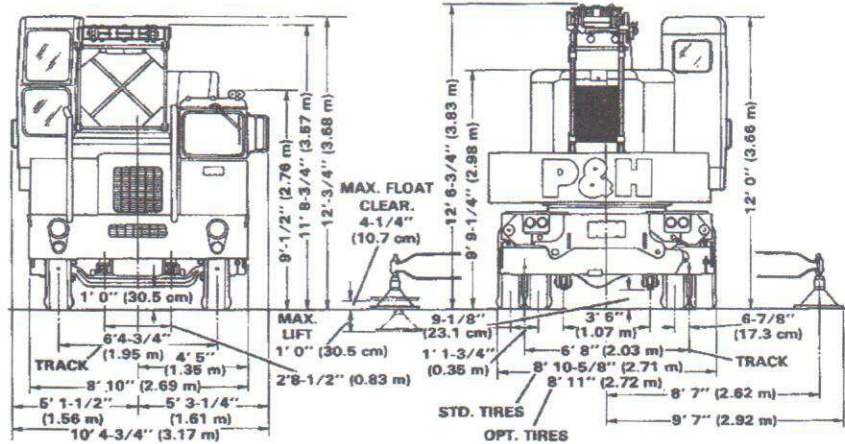
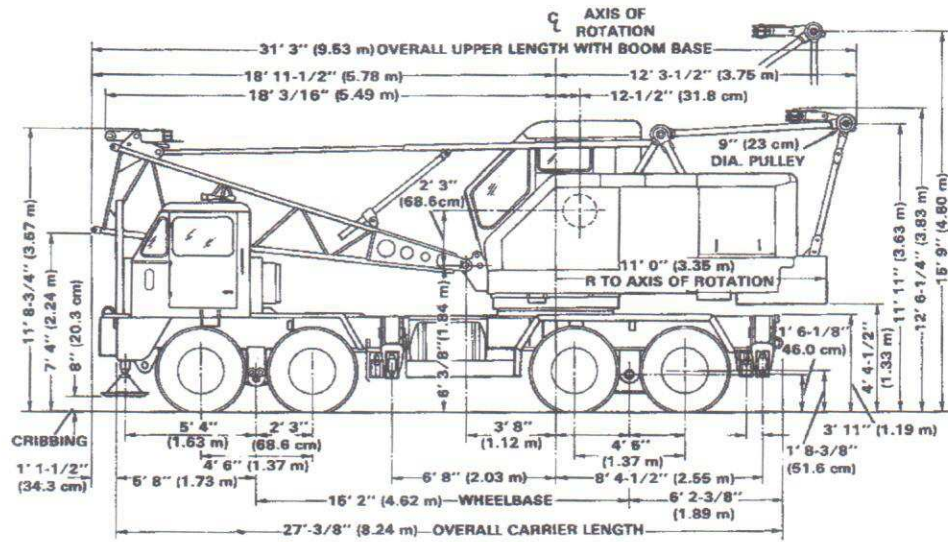

TURNING RADIUS 46.5 FEET (13.9 m)

NOTE: WHEN USING OPTIONAL TIRES, (12.00 x 20-14 PR) ADD ONE INCH (2.5 cm) TO ALL GROUND LINE DIMENSIONS.

8105J278



NOTE: All designs, specifications and components of the equipment described above are subject to change at the manufacturer's sole discretion at any time without advance notice. Data published herein is informational in nature and shall not be construed to warrant suitability of the machine for any particular purpose as performance may vary with the conditions encountered. The only warranty applicable is our standard written warranty for this machine. Manufactured and sold in conformance with U. S. Department of Commerce Commercial Standard CS-90-58.



Address inquiries to:

# P&H<sup>®</sup> 430A-TC

## 35-ton Truck Crane 150' Boom plus 40' Jib 170' Boom

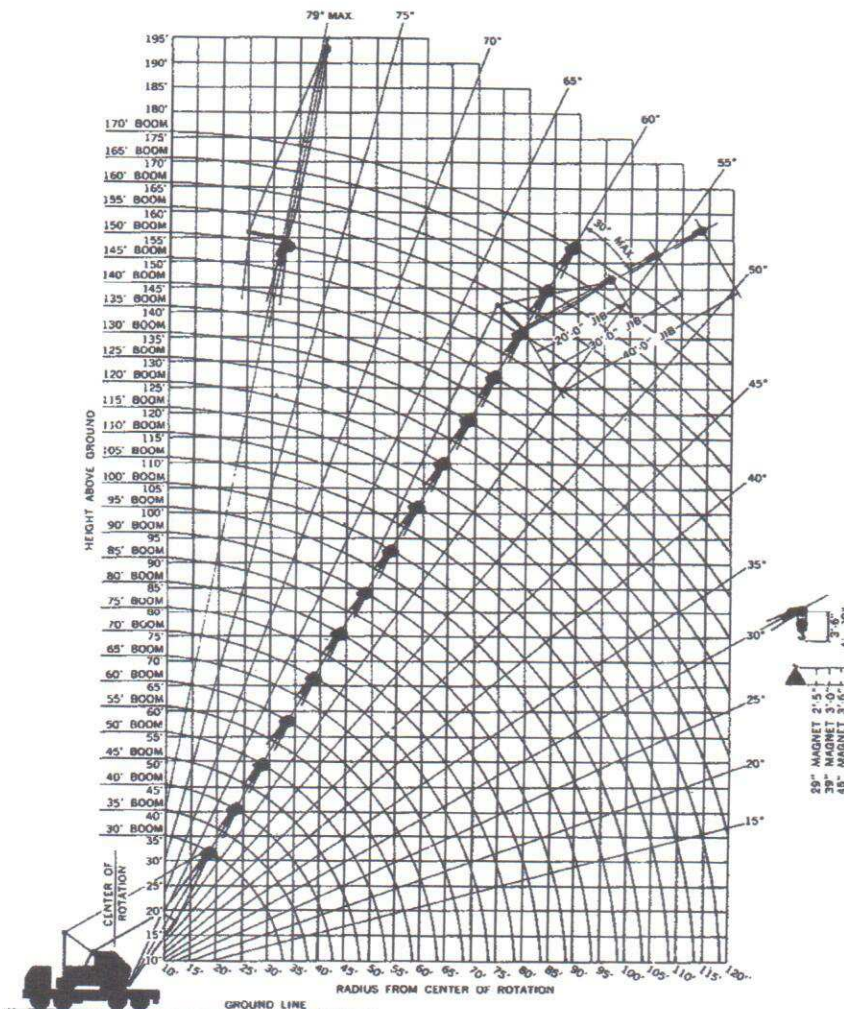

Your versatile P & H 430A-TC adapts readily to your special operating needs. This brochure contains these crane rating charts:

### Standard Boom:

- 1 • 10,100 lbs. counterweight
  - on outriggers
  - 30 to 170 foot booms
- 2 • 10,100 lbs. counterweight
  - on rubber
  - 30 to 100 foot booms

### Jib Ratings

This P&H Model 430A-TC meets the requirements of ANSI B30.5 1968. Boom structure has been tested per SAE J 987. Machine stability has been tested per SAE J 765.

**Standard  
42" wide x 42" deep  
Boom**

**crane lifting capacities  
working ranges**

# .100 lbs. counterweight

## Side and over rear work areas with outriggers fully extended and set

Angle	100 Ft. Boom		110 Ft. Boom		120 Ft. Boom		130 Ft. Boom		140 Ft. Boom		150 Ft. Boom		160 Ft. Boom		170 Ft. Boom		Oper. Rad. Ft.							
	Boom Pt. El.	Rating Lbs.	Boom Pt. El.	Rating Lbs.	Boom Pt. El.	Rating Lbs.	Boom Pt. El.	Rating Lbs.	Boom Pt. El.	Rating Lbs.	Boom Pt. El.	Rating Lbs.	Boom Pt. El.	Rating Lbs.	Boom Pt. El.	Rating Lbs.								
																	10							
			NOT MORE THAN ONE 10 FT. INSERT PERMITTED IN BOOMS OVER 100 FT. LONG.											12										
											MIDPOINT SUSPENSION (CENTER HITCH) REQUIRED ATTACH 55 FT. UP BOOM FROM BOOM FOOT PIN.						15							
																	20							
78	105.1	35,600															25							
75	103.9	26,700	77	114.2	26,600	78	124.5	26,400	79	134.7	23,600						30							
72	102.4	21,200	74	112.9	21,100	75	123.3	20,900	76	133.6	20,700						35							
69	100.7	17,400	71	111.3	17,200	73	121.8	17,100	74	132.3	16,900	75	142.6	16,700	76	152.9	16,400	77	163.2	14,000	78	173.4	12,100	40
66	98.6	14,600	68	109.5	14,500	70	120.4	14,300	72	130.7	14,100	73	141.2	14,000	74	151.6	13,800	75	162.0	13,500	76	172.3	11,100	45
63	96.2	12,500	65	107.4	12,400	68	118.3	12,200	69	129.0	12,000	71	139.6	11,900	72	150.1	11,700	74	160.8	11,700	75	171.2	10,700	50
57	90.8	9,850	60	102.6	9,700	63	114.0	9,550	65	125.1	9,400	67	136.1	9,200	69	146.9	9,050	70	157.6	8,900	71	168.2	8,650	60
49	83.3	7,800	54	96.1	7,650	57	108.2	7,450	60	119.9	7,300	62	131.3	7,150	64	142.5	7,000	66	153.5	6,800	68	164.4	6,600	70
41	73.3	6,350	47	87.7	6,150	51	101.0	6,000	55	113.5	5,850	58	125.5	5,650	60	137.2	5,500	62	148.7	5,350	64	159.9	5,100	80
32	59.5	5,200	39	76.9	5,050	45	91.9	4,900	49	105.6	4,700	53	118.5	4,550	56	130.9	4,400	58	142.9	4,200	60	154.6	4,000	90
18	37.1	4,450	30	62.3	4,200	38	80.4	4,050	43	95.9	3,850	47	110.1	3,700	51	123.4	3,500	54	136.1	3,350	56	148.3	3,100	100
			17	38.6	3,600	29	64.8	3,350	36	83.7	3,150	41	99.8	3,000	46	114.3	2,800	49	128.0	2,650	52	141.0	2,400	110
						16	40.0	2,850	28	67.3	2,600	35	86.8	2,450	40	103.4	2,250	44	118.4	2,100	47	132.4	1,850	120

348-A

### operating instructions printed throughout this brochure are for your safety and will contribute to the long life of your P&H 430A-TC

Operating radius is the horizontal distance from center-line of rotation to a vertical line through the center of gravity of the load.

Ratings shown are only for combination of P & H manufactured upper, boom, jib, counterweights, carrier and outriggers. Boom backstops are required for all boom lengths. Boom inserts must be arranged as shown in the Boom Make-Up Chart. Standard boom hoist reeving is 12 part line. Gantry must be in raised position for all operating conditions. When boom is equipped with jib, main hook ratings must be reduced by 1000 lbs. for 20 ft. or 30 ft. jib; 1500 lbs. for 40 ft. jib. Refer to diagrams for applicable working area.

Ratings shown are based on freely suspended loads and make no allowance for such factors as wind effect on lifted loads, ground conditions, out-of-level, operating speeds or any other condition that could be detrimental to the safe operation of this equipment. The operator, therefore, has the responsibility to judge the existing conditions and reduce lifted loads and operating speeds accordingly. Ratings do not exceed 85% of tipping load as determined by SAE J 765. Deduct weight of hook block(s), slings, cement bucket, and all other load handling accessories from main boom or jib rating shown. Ratings based on 10,100 lb. counterweight.

**WARNING:** The wind effect on the lifted load can cause sufficient side load to overstress boom or jib structure. When suspended load will not remain in line with boom, derate chart 25%. We recommend stopping operation when wind is above 30 m.p.h. and tying off or lowering boom when wind is above 50 m.p.h. When continued operation under windy conditions is necessary, consult factory for special derated-load rating chart.

Maximum approved travel speed with 4,100 lb. front bumper counterweight installed is 5 m.p.h. All tires must be evenly inflated to 100 P.S.I. Maximum approved boom length for travel is 100 ft. or 80 ft. boom and 20 ft. jib. Boom must be positioned over rear of carrier. Gantry must be in raised position to travel with boom attached.

**WARNING:** When 5/8 inch diameter P & H type 11 wire rope (18 x 7 non-rotating preformed plow steel wire rope fiber core) is used for jib line maximum lifted load including hook must not exceed 6,120 lbs. Do not use dead-end swivels with non-rotating wire rope.

P & H type 4 wire rope: 6 x 25 with filler wire, preformed improved plow steel wire rope 7 x 7 I.W.R.C.

**WARNING:** When assembling boom inserts, do not cantilever more than 50 ft. of inserts past point of pendant rope attachment to boom. Relocate point of attachment out on boom as additional inserts are added.

Oper. Rad. Ft.
10
12
15
20
25
30
35
40
45
50
60
90
100

## WARNING

Using this equipment in excess of rated loads, in areas of chart not rated, or with disregard of instructions will result in unsafe operating conditions and is a violation of the U.S. Dept. of Labor Safety and Health Regulations for Construction.

**1. rated crane loads in pounds — main boom (42" w. x 42" d.) in over side**

Oper. Rad. Ft.	30 Ft. Boom		40 Ft. Boom		50 Ft. Boom		60 Ft. Boom		70 Ft. Boom		80 Ft. Boom		90 Ft. Boom		100	
	Angle	Boom Pt. El. Rating Lbs.	Angle	Boom Pt. El. Rating Lbs.	Angle	Boom Pt. El. Rating Lbs.	Angle	Boom Pt. El. Rating Lbs.	Angle	Boom Pt. El. Rating Lbs.	Angle	Boom Pt. El. Rating Lbs.	Angle	Boom Pt. El. Rating Lbs.	Angle	Boom Pt. El.
10	79	36.7 70,000														
12	75	36.2 66,600	79	46.5 66,300												
15	69	35.3 61,600	75	45.8 61,300	78	56.1 61,000										
20	58	32.8 53,300	67	44.1 53,200	72	54.7 53,100	75	65.2 53,000	77	75.5 52,200						
25	46	28.9 36,600	59	41.5 36,500	66	52.8 36,400	70	63.6 36,300	73	74.1 36,100	75	84.5 35,900	77	94.8 35,700	78	105.1
30	30	22.2 28,000	50	37.9 27,600	59	50.2 27,500	65	61.5 27,400	69	72.4 27,200	71	83.0 27,000	73	93.5 26,800	75	103.9
35			40	32.7 22,100	52	46.7 22,000	59	58.8 21,800	64	70.2 21,700	67	81.2 21,500	70	91.9 21,300	72	102.4
40			26	24.5 18,500	44	42.1 18,200	53	55.5 18,100	59	67.5 17,900	64	78.9 17,700	67	89.9 17,500	69	100.7
45					35	35.9 15,500	47	51.3 15,300	54	64.2 15,100	59	76.2 14,900	63	87.6 14,800	66	98.6
50					23	26.5 13,500	40	45.9 13,200	49	60.2 13,000	55	72.9 12,900	59	84.8 12,700	63	96.2
60							23	30.4 10,600	38	50.4 10,300	47	65.3 10,200	52	78.5 9,950	57	90.8
70									21	32.3 8,350	36	53.6 8,100	44	69.4 7,900	49	83.3
80											20	34.0 6,700	33	56.7 6,450	41	73.3
90													19	35.6 5,400	32	59.5
100															18	37.1
110		JIB LENGTH	20 Ft.	30 Ft.	40 Ft.											
120		DEDUCT — LBS.	1,500	1,900	1,500											

32R48-A

**WARNING:** When operating crane "without outriggers" loads lifted over rear and swung over side, will increase in radius due to tire deflection. This increase in radius must be compensated for by raising boom, or machine may tip over.

**WARNING:** Welding or other repair to tubular steel booms may weaken the structure. See your P & H dealer for authorized boom repair service. Unauthorized repair will void all warranties.

**2. rated crane loads in pounds — main boom — without outriggers — tires at 85 p.s.i.**

Oper. Rad. Ft.	Angle	30 Ft. Boom		40 Ft. Boom		50 Ft. Boom		60 Ft. Boom		70 Ft. Boom		80 Ft. Boom		90 Ft. Boom		100 Ft. Boom		Oper. Rad. Ft.
		Over Side	Over Rear	Over Side	Over Rear	Over Side	Over Rear	Over Side	Over Rear	Over Side	Over Rear	Over Side	Over Rear	Over Side	Over Rear	Over Side	Over Rear	
10	79	34,900	42,700															10
12	75	30,700	38,500	79	30,000 38,300													12
15	69	25,000	32,600	75	24,900 32,500	78	24,300 32,300											15
20	58	18,600	22,600	67	18,400 22,500	72	18,300 22,300	75	18,100 22,100	77	17,900 21,900							20
25	46	14,000	17,100	59	13,800 17,000	66	13,600 16,800	70	13,400 16,600	73	13,200 16,400	75	13,000 16,200	77	12,800 16,000	78	12,700 15,900	25
30	30	11,700	13,900	50	11,300 13,500	59	11,200 13,400	65	11,000 13,200	69	10,800 13,000	71	10,600 12,800	73	10,400 12,600	75	10,300 12,400	30
35				40	9,250 11,500	52	9,050 11,400	59	8,900 11,200	64	8,700 11,000	67	8,500 10,800	70	8,300 10,600	72	8,200 10,500	35
40				26	7,700 9,700	44	7,550 9,550	53	7,400 9,350	59	7,200 9,200	64	7,000 9,000	67	6,800 8,800	69	6,700 8,650	40
45						35	6,400 8,150	47	6,250 8,000	54	6,050 7,800	59	5,850 7,600	63	5,650 7,400	66	5,550 7,300	45
50						23	5,500 7,100	40	5,350 6,900	49	5,150 6,750	55	4,950 6,550	59	4,750 6,350	63	4,650 6,200	50
60								23	4,150 5,450	38	3,850 5,150	47	3,650 4,950	52	3,450 4,750	57	3,350 4,650	60
70										21	3,050 4,150	36	2,750 3,850	44	2,550 3,650	49	2,450 3,550	70
80												20	2,200 3,150	33	1,900 2,850	41	1,750 2,750	80
90														19	1,450 2,300	32	1,250 2,100	90
100															18	950 1,700	100	

**NOTE: OPERATION OF THIS EQUIPMENT IN EXCESS OF LOAD RATINGS AND DISREGARD OF INSTRUCTIONS VOIDS THE WARRANTY.**

# jib ratings, drum data, reeving and boom make-up

MAIN HOIST DRUM RATED LOADS FOR THREE-QUARTER INCH DIA. P&H TYPE 4 WIRE ROPE						
Number of Parts of Main Hoist Reeving	1	2	3	4	5	6
Maximum Load — Lbs.	12,000	24,000	36,000	48,000	60,000	70,000

Maximum Boom Length to Lift Off Ground						
Boom Over	Without Front Bumper Counterweight				With 4,100 Lbs. Front Bumper Counterweight and Outriggers Set *	
	Without Outriggers Set		With Outriggers Set		Boom Only	Boom & Jib
	Boom Only	Boom & Jib	Boom Only	Boom & Jib		
Side	90	70 + 20	150	130 + 30	150	130 + 30
Rear	100	100 + 20	170	150 + 30	170	150 + 40

\*Front bumper counterweight is not an operating counterweight — is used only to erect boom with jib (30' and longer) over the rear without load.

BOOM MAKE-UP ARRANGEMENT CHART	
BOOM LENGTH FT.	BOOM ARRANGEMENT
	BASE LENGTH = 15 FT; TIP LENGTH = 15 FT. INSERTS: A = 10 FT; B = 20 FT; C = 30 FT.
70	BASE — A-C - TIP
80	BASE — B-C - TIP
90	BASE — A-B-C - TIP
100	BASE — A-C-C - TIP
110	BASE — B-C-C - TIP
120	BASE — A-B-C-C - TIP
130	BASE — A-C-C-C - TIP
140	BASE — B-C-C-C - TIP
150	BASE — A-B-C-C-C - TIP
160	BASE — B-B-C-C-C - TIP
170	BASE — A-C-B-B-C-C - TIP

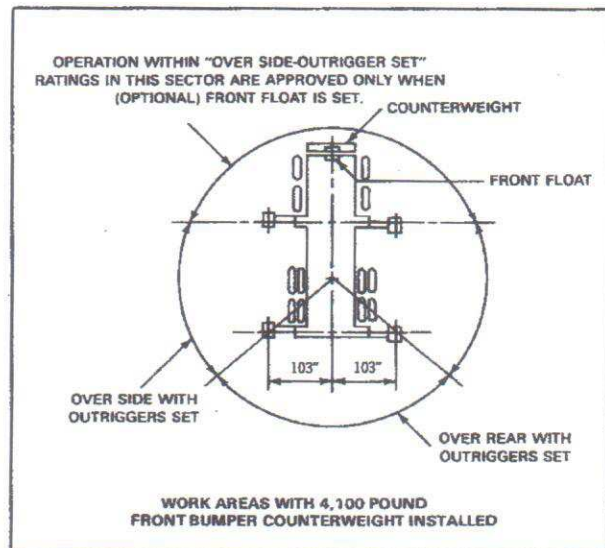
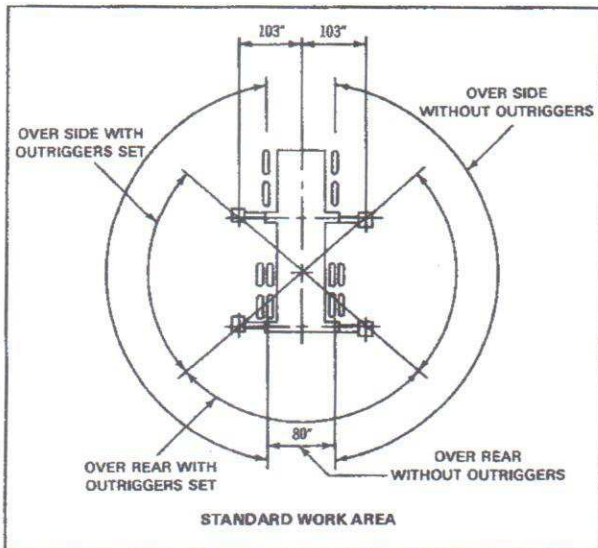

Maximum Jib (20"W. x 16"D.) Ratings for Lifting Crane Service — Lbs.			
Five-Eighths Inch Dia. P&H Type 4 Wire Rope			
Offset Angle Jib to Boom Under Full Load	20 Ft. Jib	30 Ft. Jib	40 Ft. Jib
10°	10,000	8,000	6,000
20°	9,000	7,000	5,000
30° Max.	8,000	6,000	4,000
Maximum Jib Ratings for Bucket Service			
10°	8,000	6,400	4,800
20°	7,200	5,600	4,000
30° Max.	6,400	4,800	3,200

Jib crane ratings are based on strength of materials. When main boom load rating at operating radius is less than maximum jib ratings stability governs and the lower value of main boom load rating must be used. Jibs are intended to increase lifting height, not operating radius, therefore maximum jib operating radius is limited to maximum rated radius of boom length on which jib is mounted.

Locate jib backstay anchor to top end of second insert below boom tip section.

Recommended Wire Rope Length for Drums — Ft.					
Boom Length Fl.	Main Hoist Drum	Jib Hoist Drum	Boom Length Fl.	Main Hoist Drum	Jib Hoist Drum
30	260	—	110	475	325
40	330	185	120	515	345
50	400	205	130	420	365
60	405	225	140	450	385
70	465	245	150	480	405
80	355	265	160	510	—
90	395	285	170	540	—
100	435	305			



NOTE: All designs, specifications and components of the equipment described above are subject to change at the manufacturer's sole discretion at any time without advance notice. Data published herein is informational in nature and shall not be construed to warrant suitability of the machine for any particular purpose as performance may vary with the conditions encountered. The only warranty applicable is our standard written warranty for this machine. Manufactured and sold in conformance with U. S. Department of Commerce Commercial Standard CS-90-58.



Address inquires to:



# P&H<sup>®</sup> 430A-TC

## 35-ton Truck Crane

Item	Description of Item(s)	Total Weight Or Adjustment Lbs/Kgs	Boom Over Front of Carrier		Boom Over Rear of Carrier	
			Front Tandem Weight Lbs/Kgs	Rear Tandem Weight Lbs/Kgs	Front Tandem Weight Lbs/Kgs	Rear Tandem Weight Lbs/Kgs
1*	Basic Machine Including: Hyd. O/R Assembly w/Floats (4) 11:00 x 20/(12PR) Tires (12) Upper Gantry — Lowered Position Slewing Rim Cast Counterweight 40 Gal. Fuel — Upper 20 Gal. Fuel — Lower No Crane Attachments	66820/30310	8960/4064	57860/26245	33380/15141	33440/15168
1A*	Complete Basic Machine Including: Carrier Upper 30 Ft. Basic Boom Backstop Assembly Cast Counterweight Gantry — Lowered Position 0.500 In. Dia. x 370 Ft. Wire Rope (Boom Hoist) 0.750 In. Dia. x 530 Ft. Wire Rope (Load Hoist) 40 Gal. Fuel — Upper 20 Gal. Fuel — Lower	71140/32269	15460/7013	55680/25256	28460/12909	42680/19360
2	Effect of Removing: Cast Counterweight	-10200/-4627	4620/2096	-14820/-6722	-8820/-4001	-1380/-626
3	O/R Beams — Frt. (2)	-1060/-481	-698/-317	-362/-164	-698/-317	-362/-164
4	O/R Beams & Horiz. Cyl. — Frt. (2)	-1250/-567	-823/-373	-427/-194	-823/-373	-427/-194
5	O/R Boxes, Beams & Horiz. Cyl. — Frt. (2)	-2250/-1021	-1482/-672	-768/-348	-1482/-672	-768/-348
6	O/R Vert. Cyl. & Trunnions — Frt. (2)	-380/-172	-250/-113	-130/-59	-250/-113	-130/-59
7	O/R Beams — Rear (2)	-1060/-481	353/160	-1413/-650	353/160	-1413/-650
8	O/R Beams & Horiz. Cyl. — Rear (2)	-1250/-567	417/189	-1667/-756	417/189	-1667/-756
9	O/R Boxes, Beams & Horiz. Cyl. — Rear (2)	-2250/-1021	783/355	-3033/-1376	783/355	-3033/-1376
10	O/R Vert. Cyl. & Trunnions — Rear (2)	-380/-172	127/58	-507/-230	127/58	-507/-230
11	15 Ft. Std. Boom Tip Including: Tip Guy Lines Boom Point Sheave Assembly	-970/-440	-1973/-895	1003/455	1624/737	-2594/-1177
12	15 Ft. Boom Base Including: Backstop Assembly Upper Spreader	-1315/-596	-1205/-547	-110/-50	699/317	-2014/-914
13	Backstop Assembly	-275/-125	-159/-72	-116/-53	51/23	-326/-148
14	Upper Spreader	-320/-145	-395/-179	75/34	274/124	-594/-269
15*	Basic Upper Including: Gantry — Lowered Position 40 Gal. Fuel	-32260/-14633	5440/2468	-37700/-17101	-18980/-8609	-13280/-6024
16	Slewing Rim w/Bolts	-1774/-805	-351/-159	-1423/-646	-351/-159	-1423/-646
17	Hydraulic O/R for Manual O/R	-720/-327	-115/-52	-605/-274	-115/-52	-605/-274

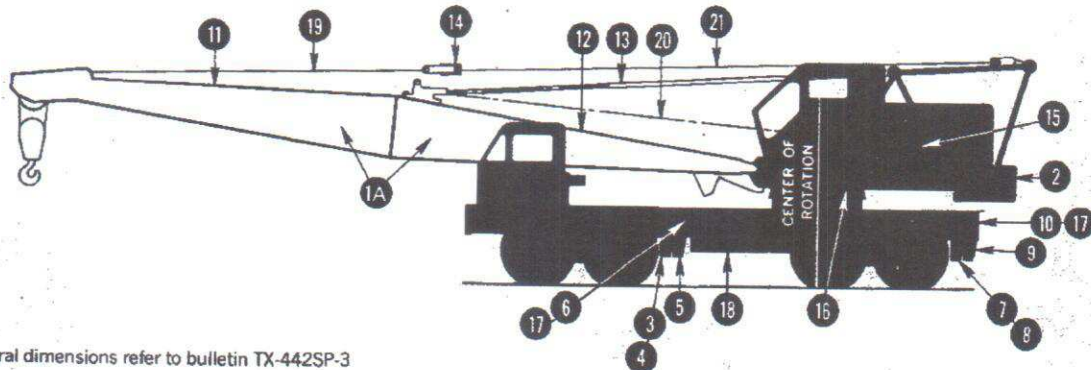

For general dimensions refer to bulletin TX-442SP-3

**axle loadings**

# P&H® 430A-TC

## 35-ton Truck Crane wire rope chart

FOR 42" x 42" BOOM

FOR	BOOM	WIRE	ROPE	PARTS OF LINE — CRANE*						DRAG- LINE	CLAM- SHELL	PILE DRIVER	HOE
	LENGTH	TYPE	DIA.	1	2	3	4	5	6				
	FT.	NO.	IN.	FT.	FT.	FT.	FT.	FT.	FT.				
BOOM HOIST LINE	19½	4	1/2										85
	ALL	4	1/2	370' — 12 PARTS LINE									
BOOM GUYLINES	ALL	4	1	REFER TO PARTS BOOK									
HOIST LINE	30	4	3/4	85	120	155	190	225	260				
	40	4	3/4	105	150	195	240	285	330				
	50	4	3/4	125	180	235	290	345	400				
	60	4	3/4	145	210	275	340	405					
	70	4	3/4	165	240	315	390	465					
	80	4	3/4	185	270	355							
	90	4	3/4	205	300	395							
	100	4	3/4	225	330	435							
	110	4	3/4	245	360	475							
	120	4	3/4	265	390	515							
	130	4	3/4	285	420								
	140	4	3/4	305	450								
	150	4	3/4	325	480								
	160	4	3/4	345	510								
170	4	3/4	365	540									
HOIST LINE (RIGHT)	19½	4	3/4										95
	30	4	3/4							80			
	40	4	3/4							100			
	50	4	3/4							120			
DIGGING LINE (LEFT)	19½	4	3/4										65
	30	4	3/4							40			
	40	4	3/4							50			
CLOSING LINE	30	4	5/8								105		
	40	4	5/8								125		
	50	4	5/8								145		
HOLDING LINE	30	4	5/8								90		
	40	4	5/8								110		
	50	4	5/8								130		
TAG- LINE	30	12	3/8								60		
	40	12	3/8								60		
	50	12	3/8								60		
LEAD LINE SUSPENSION 3rd DRUM	30	4	1/2									75	
	40	4	1/2									95	
	50	4	1/2									115	
HAMMER HOIST LINE	30	4	5/8									75	
	40	4	5/8									95	
	50	4	5/8									115	
PILE HOIST LINE	30	4	5/8									90	
	40	4	5/8									110	
	50	4	5/8									130	

\*EXTRA ROPE LENGTH REQUIRED FOR  
OPERATING BELOW GROUND LEVEL

2105N159-B

CONTINUED

P & H type 4 wire rope: 6 x 25 with filler  
wire, preformed improved plow  
steel wire rope, 7 x 7 I.W.R.C.

P & H type 12 wire rope: 6 x 37 with filler  
wire, preformed improved plow  
steel wire rope fibre core.

FOR	BOOM LENGTH FT.	WIRE ROPE		PARTS OF LINE		
		TYPE NO.	DIA. IN.	20' JIB	30' JIB	40' JIB
				1	1	1
JIB HOIST LINE	30	4	5/8	125	145	
	40	4	5/8	145	165	185
	50	4	5/8	165	185	205
	60	4	5/8	185	205	225
	70	4	5/8	205	225	245
	80	4	5/8	225	245	265
	90	4	5/8	245	265	285
	100	4	5/8	265	285	305
	110	4	5/8	285	305	325
	120	4	5/8	305	325	345
	130	4	5/8	325	345	365
	140	4	5/8	345	365	385
	150	4	5/8	365	385	405
GUYLINE JIB TO STRUT	All	4	3/4	45	65	85
GUYLINE STRUT TO BOOM	30	4	3/4	36	36	
	40	4	3/4	56	56	56
	50	4	3/4	76	76	76
	60 to 150	4	3/4	96	96	96

2105N159-B



**NOTE:** All designs, specifications and components of the equipment described above are subject to change at the manufacturer's sole discretion at any time without advance notice. Data published herein is informational in nature and shall not be construed to warrant suitability of the machine for any particular purpose as performance may vary with the conditions encountered. The only warranty applicable is our standard written warranty for this machine. Manufactured and sold in conformance with U. S. Department of Commerce Commercial Standard CS-90-58.

**Harnischfeger**

**P&H**

Milwaukee, Wisconsin 53204



Address inquires to:

**NOTE:** All designs, specifications and components of the equipment described above are subject to change at the manufacturer's sole discretion at any time without advance notice. Data published herein is informational in nature and shall not be construed to warrant suitability of the machine for any particular purpose as performance may vary with the conditions encountered. The only warranty applicable is our standard written warranty for this machine. Manufactured and sold in conformance with U. S. Department of Commerce Commercial Standard CS-90-58.



MILWAUKEE, WISCONSIN 53201

Item	Description of Item(s)	Total Weight Or Adjustment Lbs./Kgs	Boom Over Front of Carrier		Boom Over Rear of Carrier	
			Front Tandem Weight Lbs./Kgs	Rear Tandem Weight Lbs./Kgs	Front Tandem Weight Lbs./Kgs	Rear Tandem Weight Lbs./Kgs
18*	Basic Carrier, Including: Hyd. O/R Assembly w/ Floats (4) 11-00 x 20 (12 PR) Tires (12) 20 Gal. Fuel	34560/15676	14400/6532	20160/9145	14400/6532	20160/9145
19	Miscellaneous Weights: Wire Rope 1,000 In. Dia. (Lbs./Ft./Kgs./mm)	1,848/2,750 x 10 <sup>-3</sup>				
20	Wire Rope 0.760 In. Dia. (Lbs./Ft./Kgs./mm)	1,032/1,536 x 10 <sup>-3</sup>				
21	Wire Rope 0.500 In. Dia. (Lbs./Ft./Kgs./mm)	432/642 x 10 <sup>-4</sup>				
	Bottom Block (1 Sheave — 20T)	350/159				
	Bottom Block (2 Sheave — 30T)	400/181				
	Bottom Block (3 Sheave — 35T)	490/222				
	Swivel	14.75/6.69				
	Effect of Adding:					
	None					

**CRANE ATTACHMENTS (42" X 42" W/STD. TIP)**

Boom Length Ft./mm	Insert(s) Ft./mm	Attachment Wt. Lbs./Kgs	Attachment C of G From Base In./mm	Gross Vehicle Wt. Lbs./Kgs ***	FRONT OF CARRIER			BOOM OVER CARRIER			Overall Length Ft./mm	Rear Tandem Weight Lbs./Kgs	Overall Length Ft./mm
					Front Tandem Weight Lbs./Kgs	Rear Tandem Weight Lbs./Kgs	Overall Length Ft./mm	Front Tandem Weight Lbs./Kgs	Rear Tandem Weight Lbs./Kgs	Overall Length Ft./mm			
30/9144	Basic	2285/1036	177.0/4496	69105/31346	12136/5505	56969/25841	4638/14137	31058/14088	38047/17258	53.72/16374			
40/12192	10/305	2745/1245	229.9/5839	69585/31555	13557/6149	56008/25405	56.16/17118	29792/13514	39773/18041	63.72/19422			
50/15240	20/610	2985/1354	283.8/7209	69805/31664	14823/6724	54982/24940	65.94/20099	28595/12971	41210/18693	73.72/22470			
60/18288	10-20/305-610	3445/1563	336.1/8637	70266/31872	16696/7573	53559/24299	75.72/23079	28967/12187	43398/19885	83.72/25618			
70/21336	10-30/305-915	3635/1649	387.2/9835	70455/31958	18121/8220	52334/23739	85.50/26060	25487/11561	44968/20397	93.72/28566			
80/24384	20-30/610-915	3875/1758	446.6/11344	70695/32067	19982/9055	50733/23012	95.29/29044	23702/10751	48993/21316	103.72/31614			
90/27432	10-20-30/305-610-915	4335/1966	495.5/12588	71155/322776	22408/10164	48747/22112	105.07/32025	21388/9702	49767/22574	113.72/34662			
100/30480	10-30-30/305-915-915	4525/2053	553.5/14059	71345/32362	24407/11071	46938/21291	114.85/35008	19421/8809	51924/23553	123.72/37710			
110/33528	20-30-30/610-915-915	4765/2161	615.7/15639	71585/32471	26821/12166	44764/20306	124.63/37987	17050/7734	54535/24737	133.72/40758			
120/36576	10-20-30-30/305-610-915-915	5225/2370	661.9/16812	72042/32678	29842/13536	42203/19143	134.41/40968	14149/6418	57893/26260	143.72/43806			

**ALLOWABLE LOAD/TIRE LBS./KGS**

Tire Size	0-1.5 MPH		1.5-5 MPH		5-10 MPH		10-20 MPH		20-30 MPH		30-40 MPH		40-50 MPH	
	/0-2.41 KPH	/2.41-8.05 KPH	/8.05-16.09 KPH	/16.09-32.19 KPH	/32.19-48.28 KPH	/48.28-64.37 KPH	/64.37-80.47 KPH	/80.47-96.56 KPH	/96.56-112.65 KPH	/112.65-128.74 KPH	/128.74-144.83 KPH	/144.83-160.92 KPH	/160.92-177.01 KPH	/177.01-193.10 KPH
11.00 x 20/F (12 PR)	13420/6087	8840/4010	7650/3470	6850/3107	6440/2921	6020/2731	5660/2567	5240/2371	4820/2181	4400/1991	4000/1801	3600/1611	3200/1421	2800/1231
12.00 x 20/G (14 PR)	16040/7276	10510/4767	9090/4123	8100/3674	7610/3452	7120/3230	6690/3035	6280/2813	5870/2601	5460/2389	5050/2177	4640/1965	4230/1753	3820/1541

At 75 PSI/5.2 BARS

At 80 PSI/5.5 BARS

\*Actual scaled weights from "Truck Crane Weight and Compliance to B30.6-1968 Code." Dates: 7-15-71, 10-30-72, 1-18-77.  
 \*\*Crane attachment weights include boom, guy lines, boom backstops, and upper spreaders. Less bottom block.  
 \*\*\*Component list for gross vehicle weight is found under complete basic machine list. Subsequent tandem loads are calculated for the boom in travel position less bottom block.

**NOTES:** The structural material used to fabricate this model has a nominal weight tolerance of ±3%. Therefore the weight data provided should be used for reference only. To insure that any specific configuration meets local highway regulations, it is suggested that the calculated weight distribution be verified by actual scaled weights.  
 To obtain total allowable axle load, multiply the allowable single tire load by the number of tires per axle.  
 For general dimensions see Dwg. 8105J278.