

P&H

KOBELCO

T550

Hydraulic Truck Crane

*50 metric ton maximum crane load
39m maximum boom and 15m jib*



KOBE STEEL, LTD.

Bulletin No. KPT550 (N)-T

Power and stability you can

Unsurpassed lifting stability

The T550 excels in lifting stability with a maximum outrigger extension width of just 6.8 meters (22' 4"). This is made possible by the use of a strong, light boom reinforced with stiffeners and the rear-mounted design of the boom foot, boom hoist cylinders and winches. The rated crane load of a standard model with a 39 meter (127' 11") boom, for example, is 1,000 kg (2,200 lbs.) for the operating radius of 30 meters (98' 5"). The performance is second to none. The truck crane also has the widest working range in its class.

The same lifting capacity over a full 360° working area

Hydraulically operated front jack is provided under the front end of the carrier frame as optional equipment. The front jack, together with fully extended outriggers, allow the same lifting performance over a full 360° working area. So that the operator can approach his truck crane to the work site either backward or forward.

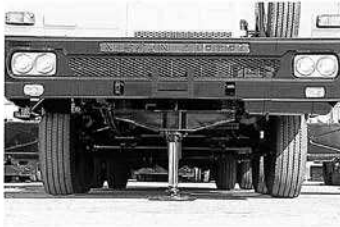

Rugged, lightweight boom

A completely new boom design is used, with a functionally-designed layout of auxiliary sheave (Patent pending) boom telescope sheaves and jib (Patent pending). This results in a rugged boom with a minimum deflection and easy handling. Travelling is also simplified by the streamlined design.

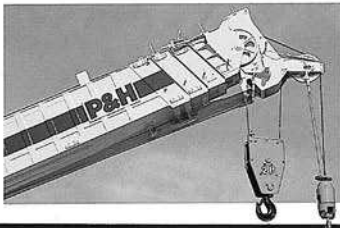

Compact design

A shorter overall length with a shorter front overhang gives the T550 greater flexibility. There's never a problem with entry to or exit from a restricted work area.

Convenient foldable auxiliary sheave (Patent pending)

- This auxiliary sheave can be stored even with the auxiliary hoisting wire rope in place. To use it, simply extend it to the position shown and insert the lock pin. You can start light lifting job at once.
- To store the sheave, just fold it up to its upright position. The boom point doesn't protrude so it never obstructs visibility during travel. This makes turning easier and safer.

Maximum jib offset angle 45°

The jib offset angle can be set at 5°, 25° or 45° depending on the work requirements. This is ideal for job at elevated heights or jobs requiring a long reach.

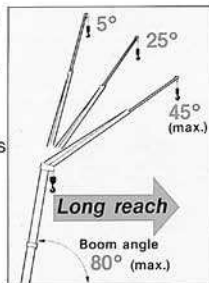

Newly designed twist jib (Patent pending)

The jib is sturdy, lightweight and compact. Its compression truss basic section incorporates a box-construction tip that can be extended when necessary. For storage, the extended jib is twisted so that its sides face up and down. It can then be turned upward to be held beside the boom. This storage arrangement assures the driver safe travelling with a wider view. Since the jib is turned downward for extension, the space required for setting can be minimized. Setting is easy even in confined areas.

Independent two-winch system for improved efficiency

The T550 uses two winches, each driven by its own independent hydraulic motor. The main winch and the auxiliary winch can, therefore, be controlled either independently or simultaneously by operating the levers. Operation is quick, positive, and safe.

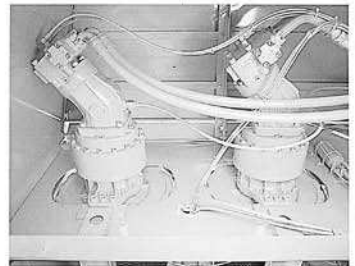

Count on to do 50-ton jobs.

Smooth swinging

The hydraulic swing control system is used to provide an outstanding swing performance. Swing speed is precisely controlled according to the lever stroke. This eliminates shock when starting and stopping. Sure and speedy operational handling is assured with minimum load shake.

Choice of "swing free" or "swing brake lock"

With the swing lever in neutral, you can select either the "swing free" or "swing brake lock" mode. Just flip the snap switch to change the mode. This ensures safe, smooth operation at all times.

"Swing free" switch which prevents sideways movement of load

Because "swing free" switches are fitted on the grips of both the main winch and auxiliary winch levers, it is possible to easily bring the boom to the load center without having to operate the swing lever. This is accomplished by activating the switch during winch lever operation.

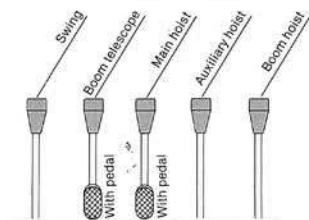

Deluxe, complete cab with added safety and comfort

The cab is extremely attractive and designed for improved work efficiency. It contains: Check-and-Safety monitor for safe operation, side console with neatly arranged switches for convenience, long main control levers that can be easily controlled with a short stroke, main winch and boom telescope levers with pedals for hand/foot control selection (for example, left hand for swing, right hand for boom hoist and right foot for acceleration or left foot for main winch), high-back reclining seat, and decorated door trim and walls. The door window is rolled up and down by a handle.

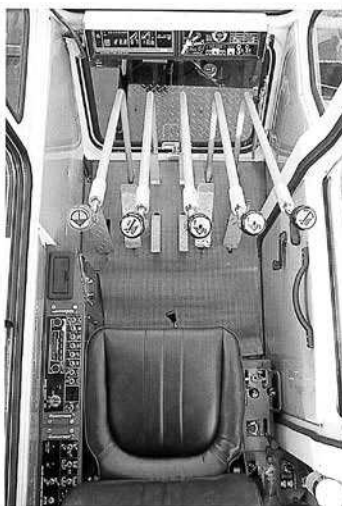

Roomy cab with excellent visibility

The Check-and-Safety monitor is inset in the front window frame for a better front view. The operation stand is eliminated to provide enough leg room and a clear downward view. The T550's cab offers roominess and excellent visibility.

2-system winch brakes for added safety

Both the main and auxiliary winches use negative/positive brake systems. The negative brake automatically functions when the winch lever is returned to neutral with the clutch lever set at ON. In addition, it functions when the clutch lever is set at OFF. With the negative brake, utmost safety is assured. The positive brake, identical in function to that of an automobile, allows free-fall braking by depressing the foot brake when the clutch lever is at the FREE position.

Check-and-Safety monitor

- Computerized monitoring display of crane operation. All necessary information during crane operation is displayed by digital and lamp indicators on a single panel for at-a-glance confirmation.
- Overload prevention data for 7 important factors are displayed. They are: lifting load (actual load), load limit (rated crane load), load moment, boom angle, boom length, operating radius and height from ground level. All data is digitally displayed, except for the load moment (%) which is indicated by a lamp.
- Working points are indicated by respective lamps on the illustrations of the main boom, jib, auxiliary sheave, working area, outrigger and main/auxiliary hook blocks. Safety monitors are provided for overload, boom angle limit, over-wind, oil temperature, accumulator pressure, and jib extended or stored.
- Automatic stopping devices assure safe crane operation to prevent overloading, over-winding and telescoping miss of boom.

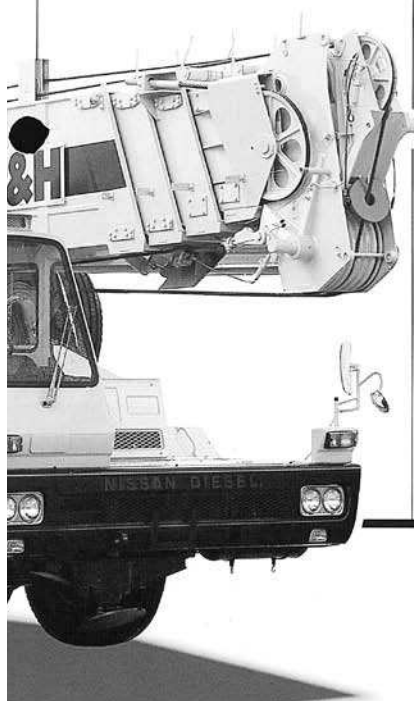

Max. lifting capacity: 50,000kg × 3.0m (110,230 lbs. × 9'10")

Max. boom & jib length: 39.0m + 15.0m (127'11" + 49'3")

Specifications

UPPER



SWING UNIT

Hydraulic axial plunger motor drives swing pinion through deck mounted planetary gear reducer. 360° continuous rotation. Brake valve can select free or lock when swing control lever in neutral position.

SWING PARKING BRAKE

Hand operated disc brake mounted on swing reducer.

SWING GEAR

Internal spur gear.

SLEWING RING

Single row ball bearing swing circle.



MAIN WINCH

Mounted on rear part of revolving frame. Driven by hydraulic axial plunger motor through planetary gear reducer and clutch.

Clutch: Band type, internal expanding with hydraulic

power.

Brake: Band type. Both positive and negative brake systems provided.

Drum: 396 mm (15.6") P.C.D., 617.5 mm (24.3") wide, 594 mm (23.4") dia. flanges.

Max. drum capacity 285 m (935')

Hoist wire rope IWRC6 x Fi (29), 18 mm (0.71") dia. 185 m (607') length.



AUXILIARY WINCH

Mounted on rear part of revolving frame. Driven by hydraulic axial plunger motor through planetary gear reducer and clutch.

Clutch: Band type, internal expanding with hydraulic

power.

Brake: Band type. Both positive and negative brake systems provided.

Drum: 396 mm (15.6") P.C.D., 617.5 mm (24.3") wide, 594 mm (23.4") dia. flanges.

Max. drum capacity 285 m (935')

Hoist wire rope IWRC6 x Fi (29), 18 mm (0.71") dia. 120 m (394') length.

(Main winch drum and auxiliary winch drum have the same dimensions except wire rope length.)

BOOM HOIST

Two double acting cylinders with integral safety holding valve.



BOOM TELESCOPE

Full power telescoping by three full power cylinders with holding valve and wire ropes.

CONTROLS

Five adjustable hand control levers for swing, telescope, boom hoist and winch (boom telescope and main winch levers with pedals), two short hand levers for main and auxiliary winch clutch and negative brake ON-OFF. One short hand lever for swing brake lock and one short hand change lever for sequence of boom telescope. Two brake pedals for main and auxiliary winch drum brake at free fall. Two foot pedals for engine throttle control.



OPERATOR'S CAB

All weather, full vision with safety glass.

SAFETY DEVICES

Boom angle indicator, over wind alarm buzzer, relief valves to prevent over-pressure to hydraulic circuits, safety holding valves for boom hoist and telescopic cylinders, counter balance valve for hoist motor, overload warning device (automatic stopping) and safety monitor (include over wind, telescoping miss, oil temperature, accumulator pressure, jib stored or extended.)

HYDRAULIC SYSTEM

POWER SYSTEM

Power for all motions of upper structure and outriggers is delivered from carrier engine PTO to the hydraulic motors and hydraulic cylinders through hydraulic pumps mounted on the carrier.

PUMPS

Carrier engine PTO drives 4-inline gear pumps.

First pump actuates boom hoist cylinders, boom telescope cylinders and winch motor assist for high speed.

Second pump actuates winch motor. Third pump actuates swing motor via outrigger hydraulic system. Fourth pump actuates pilot circuits for clutches and negative brake cylinders.

MOTORS

One, hydraulic axial plunger motor for swing.

Two, hydraulic axial plunger motor for hoist.

CONTROL VALVES

3 position 4 way double acting with integral check, and relief valves.

OIL RESERVOIR

Capacity 650 liters (171.7 US gal.)

CARRIER

• Nissan Diesel Motor KG53TXL Truck Crane Carrier; left hand steering.

• Nissan Diesel Motor KG53TXN Truck Crane Carrier; right hand steering.

• Nissan Diesel Motor KG53TXN Truck Crane Carrier (for Australia); right hand steering.

TYPE

Front engine, forward control, 8 x 4.

FRAME

All welded construction ladder type.



OUTRIGGERS

KOBELCO hydraulic H-type with self-storing floats, eight double-acting hydraulic cylinders for independent horizontal and vertical motion of each beam, manual valve controlled at side of carrier.



POWER PLANT

Nissan Diesel Motor RE8 Diesel Engine, 4 cycles, direct injection, water cooled, in-line diesel engine, 8 cylinders.

Max. output (JIS rated) 315PS at 2,300 rpm

Max. torque (JIS rated) 105 kg-m (759 ft.-lbs.) at 1,400 rpm

ELECTRICAL SYSTEM

24 volt AC. Battery: 12 volt, 120 A.H. x 2

FUEL TANK

300 liter (79.3 US gal.) capacity.

CLUTCH

Dry single plate, hydraulically control with air assisted booster.

TRANSMISSION

(KG53TXL, KG53TXN)

Model TMH502. 5 forward and 1 reverse speeds.

Sub transmission: High and low.

(KG53TXN for Australia)

Model TMH851. 9 forward and 1 reverse speeds.

BRAKE

Service: Full air brake on all 8 wheels, (dual air line system,) internal expanding (leading and trailing shoe type.)

Parking: Mechanically operated by hand brake lever, internal expanding on propeller shaft.

Auxiliary: Exhaust brake.

Emergency (Maxi brake): KG53TXN for Australia only.

SUSPENSION

Front: Semi-elliptic leaf springs.
REYCO type (KG53TXN for Australia only).
Rear: Equalizer beams and torque rods.

FRONT AXLE

Reverse—"ELLIOT" type.

REAR AXLE

Full-floating type.

TIRES

(KG53TXL, KG53TXN)

Front: Single × 4, 12.00-20-18PR

Rear: Dual × 4, 12.00-20-18PR

(KG53TXN for Australia only)

Front: Single × 4, 14/80 R20-18PR

Rear: Dual × 4, 14/80 R20-18PR

CAB

All steel welded construction, 2-man, semi-below floor type.

ATTACHMENTS

BOOM

Five sections, consisting of a boom base and four power telescoping sections, all welded high tensile steel plate box type construction.

Fully retracted length 10.6 m (34' 9")

Fully extended length 39.0 m (127' 11")

JIB

High tensile steel plate truss construction and all welded high tensile steel plate box type construction, 9.0 m (29' 6") and 15.0 m (49' 3") length. Twist jib (storage on left hand side boom basic section, downward turning for jib stretch) with suspension rod. Single sheave with ball bearing.



HOOK BLOCK

Main: 50 metric ton (110,230 lbs.) five sheaves with swivel hook and safety latch.

21 metric ton (46,300 lbs.) three sheaves with swivel hook and safety latch.

Jib: Weighted ball with swivel hook and safety latch.

AXLE LOAD

With jib, spare tire, tool and 2-man crew (150 kg) (approx.)

	KG53TXL, KG53TXN	KG53TXN for Australia
Total (G, V, W)	38,530 kg (84,940 lbs.)	38,890 kg (85,740 lbs.)
Front axle	13,360 kg (29,450 lbs.)	13,500 kg (29,760 lbs.)
Rear axle	25,170 kg (55,490 lbs.)	25,390 kg (55,980 lbs.)

PERFORMANCE

• CRANE

Max. rated lifting capacity	50 metric ton × 3.0 m (110,230 lbs. × 9' 10")	
Boom length	10.6 m ~ 39.0 m (34' 9" ~ 127' 11")	
Twist jib length	9.0 m (29' 6"), 15.0 m (49' 3")	
Boom derricking angle	- 3° ~ 80°	
*Boom derricking time	58 sec. (- 3 ~ 80°)	
*Boom telescoping time	110 sec. (10.6 m ~ 39.0 m)	
*Hoisting line speed (Main winch)	High	115 m/min (377.3 fpm) (4th layer)
	Low	55 m/min (180.4 fpm) (4th layer)
*Hoisting line speed (Aux. winch)	High	100 m/min (328.1 fpm) (2nd layer)
	Low	47 m/min (154.2 fpm) (2nd layer)
*Swing speed	0 ~ 2.1 rpm	

NOTE: *Speed; subject to no load.

• CARRIER

	KG53TXL KG53TXN	KG53TXN for Australia
Max. travel speed (estimate)	71 km/h (44.1 mph)	71 km/h (44.1 mph)
Gradeability (tan θ) (estimate)	0.28	0.46
Min. turning radius	11.8 m (38' 9")	

General Dimensions unit: mm (in)

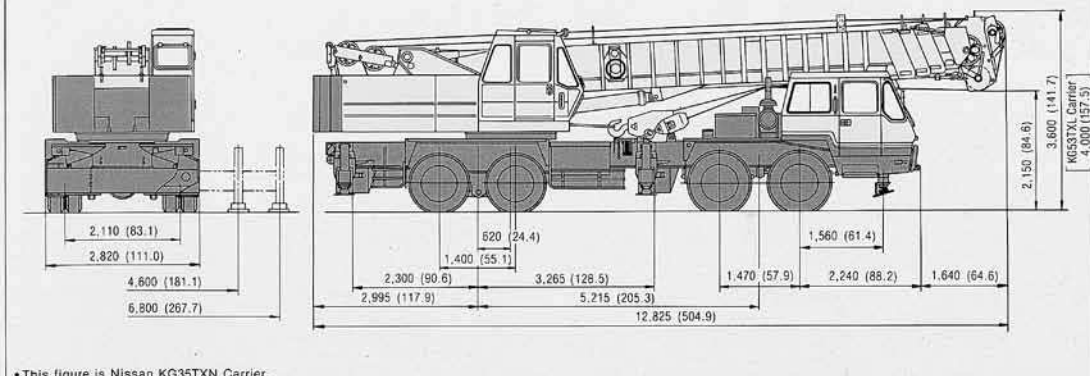

T550 Hydraulic Truck Crane

Chart 4

• With outriggers mid-extended to 4.6m (15'1") centers 360°.
• With outriggers fully extended without front jack (opt.)
—over front.

Boom Angle	39m (127'11") Boom + 9.0m (29'6") Jib			39m (127'11") Boom + 15.0m (49'3") Jib		
	Jib Offset					
	5°	25°	45°	5°	25°	45°
80°	3,500 (7,720)	2,200 (4,850)	1,200 (2,650)	2,500 (5,510)	1,200 (2,650)	600 (1,320)
79°	3,500 (7,720)	2,200 (4,850)	1,200 (2,650)	2,500 (5,510)	1,200 (2,650)	600 (1,320)
78°	3,500 (7,720)	2,200 (4,850)	1,200 (2,650)	2,500 (5,510)	1,200 (2,650)	600 (1,320)
77°	3,320 (7,320)	2,140 (4,720)	1,190 (2,620)	2,350 (5,180)	1,170 (2,580)	590 (1,300)
76°	3,130 (6,900)	2,080 (4,590)	1,180 (2,600)	2,220 (4,890)	1,140 (2,510)	590 (1,300)
75°	2,910 (6,420)	2,020 (4,450)	1,170 (2,580)	2,100 (4,630)	1,120 (2,470)	580 (1,280)
74°	2,510 (5,530)	1,960 (4,320)	1,160 (2,560)	1,980 (4,370)	1,090 (2,400)	580 (1,280)
73°	2,150 (4,740)	1,760 (3,880)	1,150 (2,540)	1,800 (3,970)	1,060 (2,340)	570 (1,260)
72°	1,840 (4,060)	1,520 (3,350)	1,130 (2,490)	1,530 (3,370)	1,040 (2,290)	570 (1,260)
71°	1,570 (3,460)	1,300 (2,870)	1,120 (2,470)	1,300 (2,870)	990 (2,180)	560 (1,230)
70°	1,330 (2,930)	1,100 (2,430)	980 (2,160)	1,100 (2,430)	840 (1,850)	560 (1,230)
69°	1,110 (2,450)	920 (2,030)	810 (1,790)	910 (2,010)	690 (1,520)	530 (1,170)
68°	900 (1,980)	740 (1,630)	650 (1,430)	740 (1,630)	550 (1,210)	390 (860)
67°	720 (1,590)	580 (1,280)	480 (1,060)	580 (1,280)	410 (900)	290 (640)
66°	550 (1,210)	430 (950)	340 (750)	430 (950)	290 (640)	
65°	380 (840)	290 (640)		290 (640)		

Chart 5

• Without outriggers —over rear.

Operating Radius in Meters (ft.-in.)	Main Boom
	10.6m (34'9") Boom
3.0 (9-10)	14,900 (30,860)
3.5 (11-6)	14,000 (30,860)
4.0 (13-1)	11,950 (26,350)
4.5 (14-9)	10,000 (22,050)
5.0 (16-5)	8,500 (18,740)
5.5 (18-1)	7,350 (16,200)
6.0 (19-8)	6,350 (14,000)
6.5 (21-4)	5,550 (12,240)
7.0 (23-0)	4,900 (10,800)
7.5 (24-7)	4,300 (9,480)
8.0 (26-3)	3,800 (8,360)
8.5 (27-11)	3,350 (7,390)

Working Ranges

■ Weight of Hook block
50 metric ton hook.....450kg (990 lbs.)
21 metric ton hook.....250kg (550 lbs.)
Weighted ball hook.....100kg (220 lbs.)

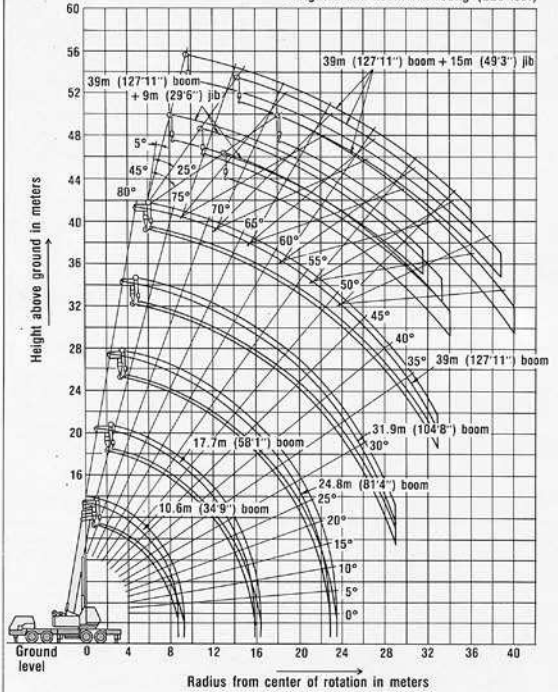

Notes:
1. The data in the figure does not include boom and jib deflections.
2. The data shown is based on the conditions when the outriggers are fully extended and the front jack (optional) is used.

8. Auxiliary sheave load ratings are the same as main boom load ratings shown on Chart 1, but do not exceed 4,000kg (8,820 lbs.). Auxiliary sheave load ratings are reduced weight of main hook block from the main boom load ratings.

9. Standard hoist reevings are shown below.

Boom length	10.6m (34'9")	10.6-17.7m (34'9"-58'1")	17.7-24.8m (58'1"-81'4")
No. of parts of line	11	6	5
Boom length	24.8-31.9m (81'4"-104'8")	31.9-39.0m (104'8"-127'11")	Aux. sheave or jib
No. of parts of line	3	2	1

- When outriggers are fully extended without the front jack, over front lifting capacities are less than those of over rear and over side. When turning the machine from over side to over front, be careful not to allow load aloft to exceed over front ratings.
- Load ratings for free fall operation are one fifth of rated loads shown above. In this case, each permissible load for single line is 900kg (1,980 lbs.) for main and auxiliary hoist line.
- The ratings for boom with 9.0m (29'6") extending jib are the value 1,700kg (3,750 lbs.) less than the value seen from Chart 1. The ratings for boom with 15.0m (49'3") extending jib are the value 2,000kg (4,410 lbs.) less than the value seen from Chart 1.
- The direction for on tire is only rear.

Working Areas

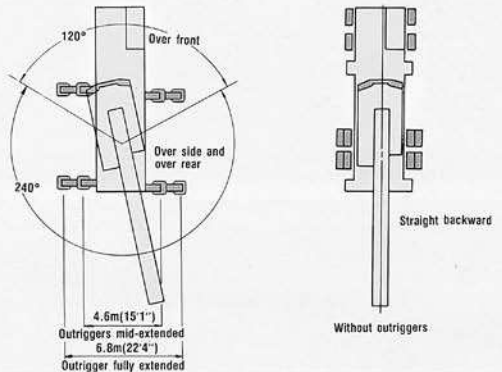



T550

Hydraulic Truck Crane

NOTE: Due to our policy of continual product improvement, all designs and specifications are subject to change without advance notice. Data herein is informational in nature and shall not be construed to warrant suitability of the machine for any particular purpose as performance may vary with the conditions encountered. These statements are correct at time of going to press.



KOBE STEEL, LTD.

CONSTRUCTION MACHINERY DIVISION

No. 27-8, 6-chome, Jingumae, Shibuya-ku, Tokyo 150, Japan

Phone: Tokyo (03) 797-7021

Telex: 2228507 KOBSTL J or KSLCONST J 29757

Cable: "KOBESTEEL TOKYO"

Address Inquiries to:

Printed in Japan 86041000 F