

P&H OMEGA[®]-65

66-ton Rough Terrain Crane

189-ft. (57.6m) maximum tip height

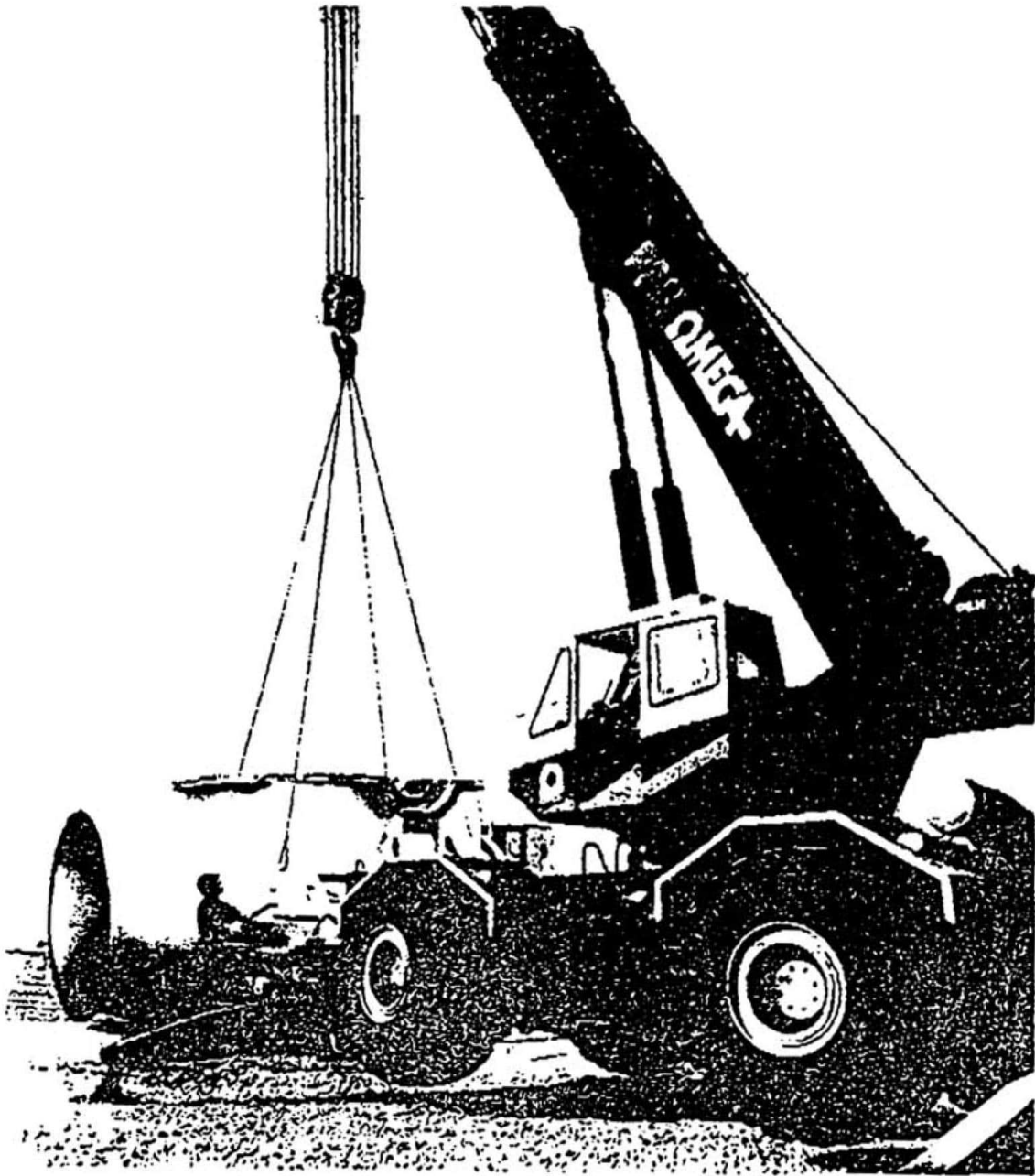

- Excellent reach afforded by telescoping 114 ft (34.7 m) 4 section boom. Add 33 ft (10.1 m) lattice boom extension and 35 ft (10.7 m) jib for total length of 182 ft (55.5 m)
- Telescope rated loads for precise placement. Semi-fixed cylinder mounts decrease cylinder deflection under load and increase telescoping capacity
- Superior lifting performance provided by rectangular full depth four-plate OMEGA boom that is welded inside and out
- Fast, solid set-up with P&H scissors type outriggers. Excellent stability due to 22'-2" (6.76 m) outrigger stance
- Total operator comfort means less fatigue and greater production. Spacious OMEGA cab module allows placement of controls "in the palm of your hand" lots of leg and elbow room and full vision of all activities
- A duty-cycle machine — OMEGA's powerful winches offer high line speeds, pull and controlled free fall. VOLUMATIK[®] hydraulic system provides optimum oil flow for fast crane functioning
- Less downtime — OMEGA is "Plt-Stop" maintenance-proven. It's industry's most serviceable crane — engineered for parts commonality, accessibility and fast tear-down.

Working Ranges

four
section
boom

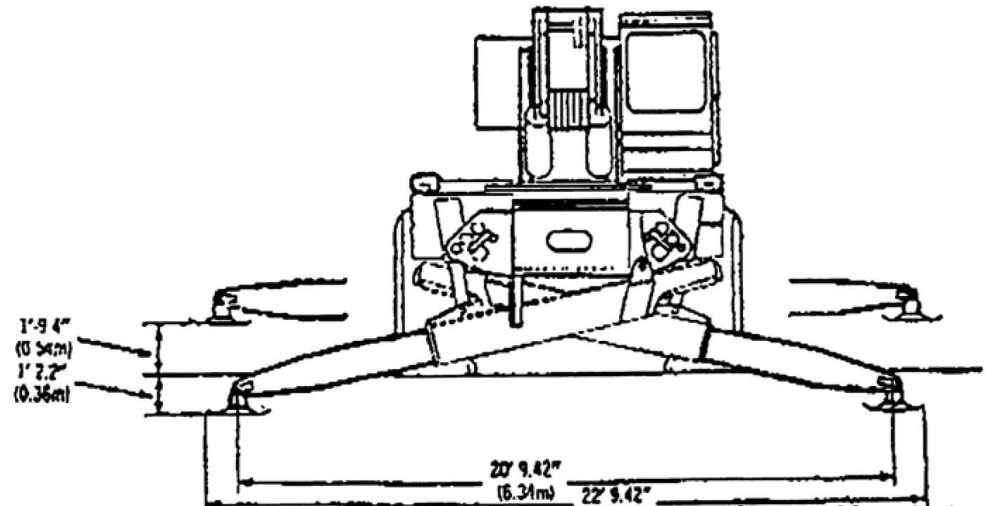
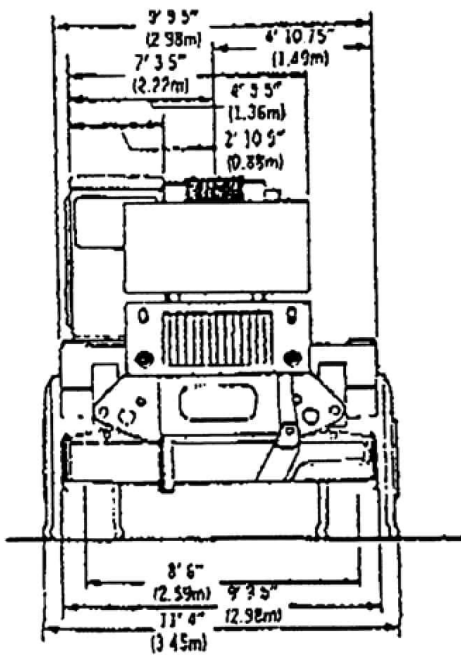
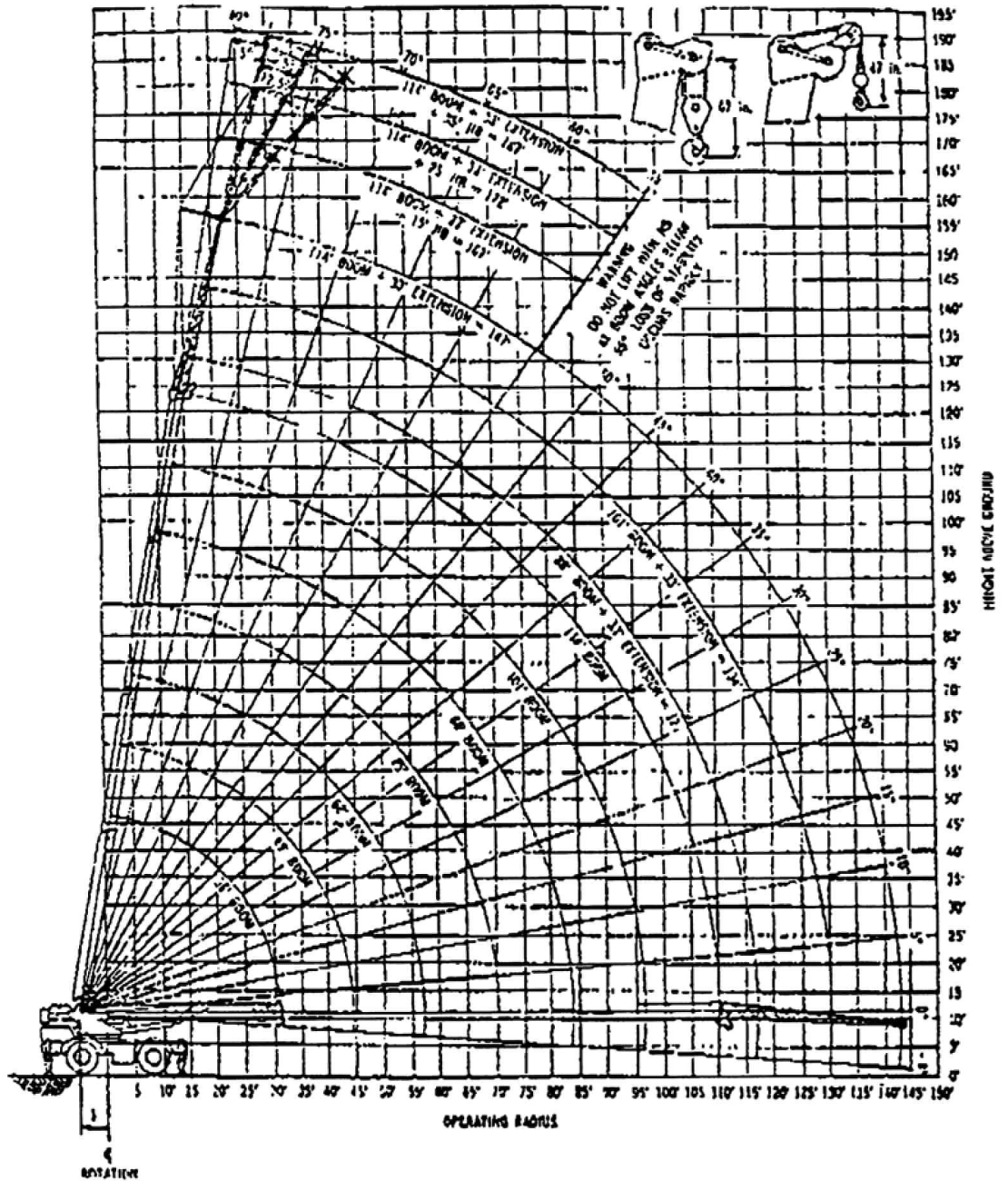

PCSA CLASS 10 — 220 full powered boom with outriggers fully extended

rated crane loads in pounds — boom in 360° and over front w

BOOM LENGTH (FEET) ALL SECTIONS EQUALLY EXTENDED																												
LOAD RADIUS (FEET)	36				42				49				62				75											
	LOADED BOOM ANGLE Δ°	RATED LOAD POUNDS		LOADED BOOM ANGLE Δ°	RATED LOAD POUNDS		LOADED BOOM ANGLE Δ°	RATED LOAD POUNDS		LOADED BOOM ANGLE Δ°	RATED LOAD POUNDS		LOADED BOOM ANGLE Δ°	RATED LOAD POUNDS		LOADED BOOM ANGLE Δ°												
		360°	FRONT		360°	FRONT		360°	FRONT		360°	FRONT		360°	FRONT		360°	FRONT										
10	70	132000	132000	73	121000	121000	76	113000	113000	79	96000	96000																
12	67	115000	115000	70	110000	110000	73	104000	104000	77	91000	91000	80	84000	84000													
15	61	94000	94000	66	89000	89000	70	87000	87000	74	83000	83000	78	76000	76000													
20	51	68000	68000	58	67000	67000	63	66000	66000	69	64000	64000	74	63000	63000	77												
25	39	51000	51000	49	50000	50000	56	49000	49000	64	48000	48000	70	47000	47000	73												
30	19	38100	41000	38	38100	41000	48	38100	41000	59	33100	41000	65	38100	41000	70												
35	TELESCOPE CYLINDERS MUST BE FULLY RETRACTED AND AGAINST STOPS			22	28300	34000	39	28300	34000	53	28300	34000	61	28300	34000	66												
40									27	22000	27600	47	22000	27600	56	22000	27600	62										
45													39	17700	22200	51	17700	22200	68									
50													31	14100	17800	46	14100	17800	54									
55										18	11300	14500	40	11300	14500	50												
60	RATINGS ABOVE THE HEAVY LINE ARE BASED ON STRUCTURAL COMPETENCE AND NOT ON MACHINE STABILITY WHEN LIFTING A LOAD <u>ALL SECTIONS OF THE BOOM MUST BE EXTENDED EQUALLY</u> WARNING: 1 FOR BOOM LENGTHS LESS THAN 134 FEET AND LESS THAN 147 FEET THE RATED LOADS ARE DETERMINED BY BOOM ANGLE ONLY IN THE COLUMNS HEADED BY 134 FOOT BOOM AND 147 FOOT BOOM FOR ANGLES NOT SHOWN USE RATING OF NEXT LOWER BOOM ANGLE 2 DO NOT EXCEED 100 FOOT OVERSIDE ON 114 FOOT BOOM A: WILL OCCUR 3 DO NOT EXCEED 110 FOOT OVERSIDE ON 134 OR 147 FOOT TIPPING WILL OCCUR.												33	9400	12200	45												
65																								24	7600	10100	40	
70																												34
80																												18
90																												
100																												
110																												
120																												
130																												

"on rubber"

rated crane loads in pounds — mi

WARNING: WITHOUT OUTRIGGER LIFTS WITH JIB OR BOOM EXTENSION IN WORKING POSITION ARE PROHIBITED

TO HELP PREVENT TIPPING CONDITIONS WHEN LIFTING ON RUBBER IT IS RECOMMENDED THAT -

- 1 MINIMUM BOOM LENGTHS BE USED NOT EXCEEDING 75 FEET
- 2 OUTRIGGERS BE EXTENDED AS FAR AS POSSIBLE AND CLEAR OF GROUND

WHEN LIFTING A LOAD ALL SECTIONS OF THE BOOM MUST BE EXTENDED EQUALLY

RATINGS FOR FULL POWER BOOM			LOAD RADIUS (FEET)
STATIONARY 360°	OVER FRONT		
	STATIONARY & CREEP	2 1/2 MPH	
44200	70900	54800	10
35600	62200	46800	12
26400	52300	37800	15
18300	40300	27600	20
9800	30700	20800	25
5700	21100	15900	30
3400	15600	12700	35
1800	11900	10200	40
—	9400	8300	45
—	7000	6500	50
—	4000	3900	60

32U1783

WARNING: DO NOT EXCEED RATE OR A TIPPING CONDIT

JIB RATINGS AND DEDUCTIONS FROM RATED LOADS

JIB CAPACITY NOTES:

1. MAXIMUM JIB LOAD RATINGS ARE BASED ON STRUCTURAL COMPETENCE AND DO NOT EXCEED 85% OF TIPPING LOAD WITH FULLY EXTENDED OUTRIGGERS. USE OF OUTRIGGERS IS REQUIRED WHEN BOOM IS EQUIPPED WITH JIB.
2. FOR BUCKET RATINGS ON JIB DEDUCT 20% FROM MAXIMUM JIB LOAD RATINGS.
3. WARNING: DO NOT LIFT WITH JIB AT BOOM ANGLES BELOW 55° LOSS OF STABILITY OCCURS RAPIDLY.
4. WARNING: DO NOT EXCEED 120 FOOT OPERATING RADIUS WITH LIFTED 15 25 OR 35 FOOT JIB OR A TIPPING CONDITION WILL OCCUR.

MAXIMUM JIB LOAD RATINGS IN POUNDS				
MINIMUM BOOM ANGLE	JIB LENGTH IN FEET			
	15	25	35	
0° OFFSET	80°	9100	7500	5000
	75°	7850	6500	4400
	70°	6650	5500	3800
	65°	5500	4500	3200
	60°	4350	3700	2900
12.5° OFFSET	80°	8100	6200	4500
	75°	7050	5500	3800
	70°	5700	4500	3000
	65°	4700	3700	2450
	60°	3950	3100	2000
25° OFFSET	80°	7300	5400	4000
	75°	5950	4500	3200
	70°	4700	3600	2500
	65°	3800	2900	2000
	60°	3250	2500	1500

DEDUCTIONS FROM RATED JIB LOADS						
HOOK BLOCK	DEDUCTIONS IN POUNDS					
	HOOK BLOCK ON BOOM POINT			HOOK BLOCK ON 33 FOOT BOOM EXTENSION		
	JIB LENGTH IN FEET					
	15	25	35	15	25	35
BALL HOOK 8.5 TON	300	250	200	350	300	250
1 SHEAVE 20 TON	500	450	400	600	500	550
5 SHEAVE 60 TON	800	750	700			

DEDUCTIONS FROM RATED LOADS FOR 33 FOOT BOOM EXTENSION WITH MANUAL EXTENDED OR RETRACTED	
HOOK BLOCK ON BOOM POINT	
HOOK BLOCK	DEDUCTION IN POUNDS
BALL HOOK 8.5 TON	300
1 SHEAVE 20 TON	500
5 SHEAVE 60 TON	1000
ERECTED JIB WITH BALL HOOK	
JIB LENGTH IN FEET	DEDUCTION IN POUNDS
15	1400
25	1700
35	2000

DEDUCTIONS FROM RATED BOOM LOADS		
BOOM CONFIGURATION		DEDUCTION IN POUNDS
RETRACTED 33 FOOT BOOM EXTENSION MANUAL EXTENDED OR RETRACTED	20 TON 1 SHEAVE	3500
	8.5 TON BALL HOOK	2700
ERECTED 15 FOOT JIB WITH BALL HOOK		4500
ERECTED 25 FOOT JIB WITH BALL HOOK		5200
ERECTED 35 FOOT JIB WITH BALL HOOK		6900
HOOK BLOCK WEIGHTS IN POUNDS		
5 SHEAVE 60 TON	1 SHEAVE 20 TON	BALL HOOK 8.5 TON
1200	400	300

WARNING: MAIN BOOM RATINGS MUST BE REDUCED BY WEIGHT OF FIXED BOOM ATTACHMENTS SEE TABLE

DEDUCTIONS FOR OPTIONAL EQUIPMENT

FOR MACHINES EQUIPPED WITH AN AUXILIARY SHEAVE, OR AN ELECTRICAL ANTI-TWO BLOCK, OR A LOAD MOMENT DEVICE 350 LBS. MUST BE DEDUCTED FROM ALL STABILITY RATINGS BELOW THE HEAVY LINE.

HOIST LINE WIRE ROPE		
TYPE	1/2" 8 x 19 IWRC	P & H TYPE 25 1/4" 6 x 25 IWRC
BRKING STRNGTH	51 800	58 800

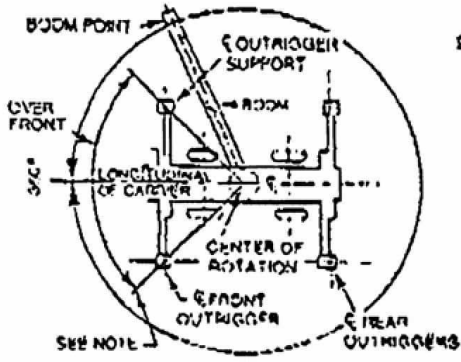

ON OUTRIGGERS

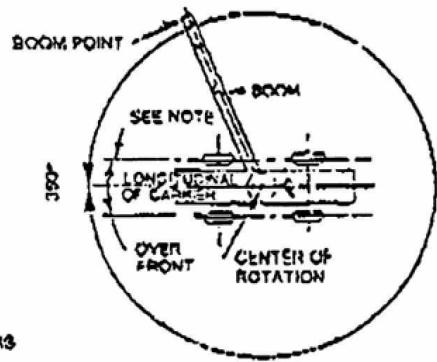

ON RUBBER

NOTE
THESE LINES DETERMINE ANY LIMITING POSITION OF ANY LOAD FOR OPERATION WITHIN WORKING AREAS INDICATED

AREAS OF OPERATION

OPERATION OF THIS EQUIPMENT IN EXCESS OF RATED LOADS AND DISREGARD OF INSTRUCTIONS WOULD BE DANGEROUS

PERMISSIBLE HOIST LINE LOAD IN POUNDS	
PARTS OF LINE	P & H #16 MAIN OR AUXILIARY WINCH
1	12,000
2	24,000
3	36,000
4	48,000
5	60,000
6	72,000
7	84,000
8	96,000
9	108,000
10	120,000

four section boom with 9,000 lbs. counterweight

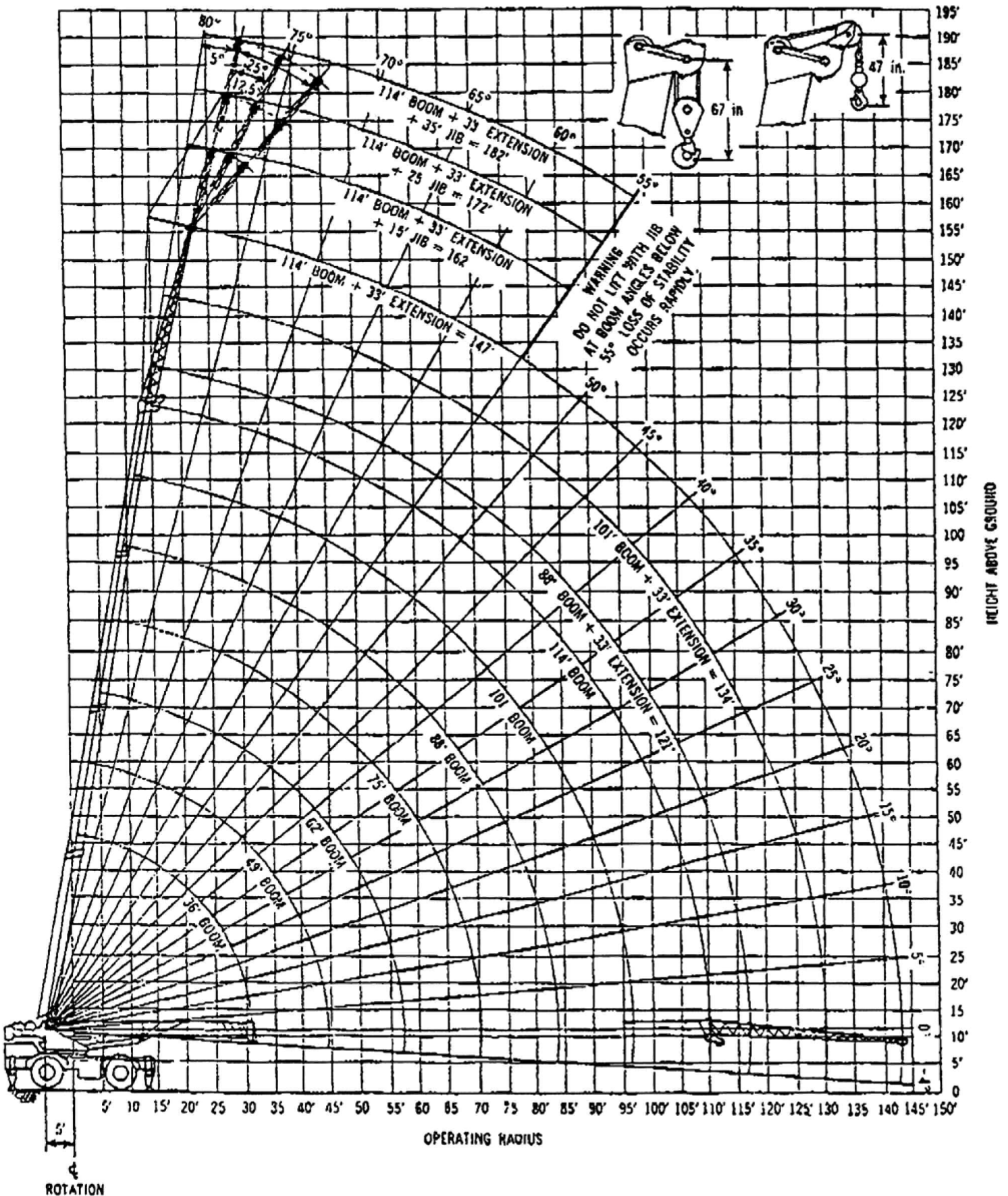

boom with 9,000 lbs. counterweight

areas with outriggers fully extended and set

EQUALLY															LOAD RADIUS IN FEET	
88			101			114			134 (SEE WARNING NOTE 1)			147 (SEE WARNING NOTE 1)				
BOOM ANGLE Δ°	RATED LOAD POUNDS		BOOM ANGLE Δ°	RATED LOAD POUNDS		BOOM ANGLE Δ°	RATED LOAD POUNDS		BOOM ANGLE Δ°	RATED LOAD POUNDS		BOOM ANGLE Δ°	RATED LOAD POUNDS			
	360°	Front		360°	Front		360°	Front		360°	Front		360°	Front	360°	Front
10															10	
12															12	
14															14	
16	73	57000	57000												16	
18	78	53000	53000	80	46000	48000									18	
20	77	50000	50000	79	44000	44000	80	30000	30000						20	
25	73	41000	41000	76	37000	37000	78	27000	27000	80	18000	18000			25	
30	70	32900	34900	73	32000	32000	75	25000	25000	78	14000	14000	79	12000	12000	30
35	66	24100	26400	70	24100	26400	73	22000	22000	76	12000	12000	78	11000	11000	35
40	62	18200	20700	67	18200	20700	70	18200	19000	74	11000	11000	76	9700	9700	40
45	58	14400	16700	63	14400	16700	67	14400	16700	72	10000	10000	74	9200	9200	45
50	54	11500	13500	60	11500	13500	64	11500	13500	69	9200	9200	72	8500	8500	50
60	45	7300	8600	53	7300	8600	58	7300	8600	65	8000	8000	68	7400	7400	60
70	34	4200	5700	45	4200	5700	52	4200	5700	60	7000	7000	64	6500	6500	70
80	18	2400	3600	36	2400	3600	45	2400	3600	55	5000	6000	59	4900	5800	80
				23	---	2000	36	2000	800	49	3500	4900	54	3300	4300	90
							26	800		43	2200	3200	49	1900	2900	100
										36	---	2200	44	1800	109	109
										26	---	900	36	800	120	120

WARNING: DO NOT EXCEED 90 FOOT RADIUS OVER SIDE WITH HOOK BLOCK ON A FULLY EXTENDED BOOM OR A TIPPING CONDITION WILL OCCUR.

WARNING: DO NOT EXCEED 109 FOOT RADIUS OVER SIDE (WITH OR WITHOUT HOOK BLOCK) OR A TIPPING CONDITION WILL OCCUR.

WARNING: WHEN LIFTING A LOAD, ALL POWERED SECTIONS OF THE BOOM MUST BE EXTENDED EQUALLY.

TIRES	
CREEP	2% MPH
60 PSI	50 PSI
75 PSI	65 PSI

NOTE: OPERATION OF THIS EQUIPMENT IN EXCESS OF LOAD RATINGS AND DISREGARD OF INSTRUCTIONS VOIDS THE WARRANTY.

EXCEED 40 RADIUS OR A TIPPING CONDITION WILL

OCUR WITHOUT OUTRIGGERS DEPEND ON TIRE AND CONDITION INFLATED PER TABLE AND WHEN REAR AXLE LOCKOUTS ARE ENGAGED OF OPERATION PLATE FOR WORKING RANGES EXCEED 50 RADIUS OR A TIPPING CONDITION WILL

OCUR WITHOUT OUTRIGGERS DEPEND ON TIRE AND CONDITION INFLATED PER TABLE, AND WHEN REAR AXLE LOCKOUTS ARE ENGAGED, OF OPERATION PLATE FOR WORKING RANGES NOT EXCEEDING 1 MPH ABOVE THE HEAVY LINE ARE BASED ON STRUCTURE AND NOT ON MACHINE STABILITY

TO HELP PREVENT TIPPING CONDITIONS WHEN "LIFTING ON RUBBER" IT IS RECOMMENDED THAT -

1. MINIMUM BOOM LENGTHS BE USED, NOT EXCEEDING 73 FEET.
2. OUTRIGGERS BE EXTENDED AS FAR AS POSSIBLE AND CLEAR OF GROUND

WARNING: WITHOUT OUTRIGGER LIFTS WITH JIB OR BOOM EXTENSION IN WORKING POSITION ARE PROHIBITED

WARNING: WHEN TRANSPORTING A LOAD, MACHINE MUST BE ON FIRM, LEVEL SURFACE WITH LOAD RESTRAINED FROM SWINGING DO NOT EXCEED 2% MPH (4 KMPH) VEHICLE SPEED

deductions to be made from rated loads

DEDUCTIONS TO BE MADE FROM MAIN BOOM RATED LOADS (IN POUNDS)

HOOK BLOCK	ON BOOM	ON LATTICE EXTENSION	ON JIB		
			15 FT.	25 FT	35 FT
66 Ton 5 Sheave	1200	—	—	—	—
20 Ton 1 Sheave	600	3500	—	—	—
8.5 Ton Ball Hook	300	2700	4500	5200	5800

DEDUCTIONS TO BE MADE FROM LATTICE EXTENSION RATED LOADS (IN POUNDS)

HOOK BLOCK	ON BOOM	ON LATTICE EXTENSION	ON JIB		
			15 FT	25 FT	35 FT
66 Ton	1200	—	—	—	—
20 Ton	600	600	—	—	—
8.5 Ton	300	300	1400	1700	2000

DEDUCTIONS TO BE MADE FROM JIB RATED LOADS (IN POUNDS)

HOOK BLOCK	ON BOOM			ON LATTICE EXTENSION			ON JIB		
	JIB LENGTH IN FEET								
	15	15	35	15	25	35	15	25	35
66 Ton	800	750	700	—	—	—	—	—	—
20 Ton	500	450	400	650	600	550	—	—	—
8.5 Ton	300	250	200	350	300	250	300	300	300

DEDUCTIONS FOR OPTIONAL EQUIPMENT

FOR MACHINES EQUIPPED WITH AN AUXILIARY SHEAVE OR AN ELECTRICAL ANTI-TWO BLOCK, OR A LOAD MOMENT DEVICE, 300 LBS MUST BE DEDUCTED FROM ALL STABILITY RATINGS BELOW THE HEAVY LINE.

PCSA CLASS 10-182 four section full

rated crane loads in pounds — main boom in 360° and over

LOAD RADIUS IN FEET	POWERED BOOM LENGTH IN FEET													
	ALL THREE POWERED SECTIONS													
	36		42		49		62		75					
	LOADED BOOM ANGLE Δ°	RATED LOAD POUNDS	LOADED BOOM ANGLE Δ°	RATED LOAD POUNDS	LOADED BOOM ANGLE Δ°	RATED LOAD POUNDS	LOADED BOOM ANGLE Δ°	RATED LOAD POUNDS	LOADED BOOM ANGLE Δ°	RATED LOAD POUNDS	LOADED BOOM ANGLE Δ°	RATED LOAD POUNDS	LOADED BOOM ANGLE Δ°	RATED LOAD POUNDS
	360°	Front	360°	Front	360°	Front	360°	Front	360°	Front	360°	Front	360°	Front
10	70	120000	120000	73	97000	97000	76	92000	92000	79	86000	86000		
12	66	105000	105000	70	90000	90000	73	86000	86000	77	81000	81000	80	77000
14	63	93000	93000	67	83000	83000	71	80000	80000	75	76000	78000	78	73000
16	59	80000	80000	64	76000	76000	68	74000	74000	73	71000	71000	77	68000
18	55	70000	70000	61	69000	69000	65	68000	68000	71	67000	67000	75	64000
20	50	62000	62000	57	61000	61000	63	60000	60000	69	59000	59000	74	58000
25	38	47000	47000	48	46000	46000	56	45000	45000	64	44000	44000	69	43000
30	18	32900	34900	37	32900	34900	48	32900	34900	59	32900	34900	65	32900
35	CAUTION: FOR 36 FOOT BOOM LENGTH RATINGS TELESCOPE CYLINDERS MUST BE FULLY RETRACTED AND AGAINST STOPS			22	24100	26400	39	24100	26400	53	24100	26400	61	24100
40							27	18200	20700	46	18200	20700	56	18200
45										39	14400	16700	51	14400
50										30	11500	13500	46	11500
													33	7300
													2	4200

WARNING

1 FOR BOOM LENGTHS LESS THAN 134 FEET AND LESS THAN 147 FEET, THE 33 FOOT BOOM EXTENSION RATED LOADS ARE DETERMINED BY BOOM ANGLE ONLY IN THE COLUMN HEADED BY 134 FOOT BOOM AND 147 FOOT BOOM RESPECTIVELY. FOR ANGLES NOT SHOWN, USE RATING OF NEXT LOWER BOOM ANGLE.

WARNING: MAIN BOOM RATINGS MUST BE REDUCED FOR FIXED BOOM ATTACHMENTS SEE TABLE

on rubber with 9,000 lbs. counterweight
 rated crane loads in pounds — main boom — without outrigger

RATINGS FOR 23.5 x 25 — 22 PLY TIRES			LOAD RADIUS IN FEET	RATINGS FOR 29.5 x 25 — 28 PLY TIRES		
STATIONARY 360° ①	OVER FRONT STATIONARY & CREEP ②			STATIONARY 360° ①	OVER FRONT STATIONARY & CREEP ②	
		2 1/2 MPH ③			2 1/2 MPH ③	
39950	61300	44750	10	44700	72000	56300
30700	53500	37950	12	35750	63200	48150
22950	44700	30350	15	24550	53200	38950
14000	34450	21700	20	14000	40550	28550
8400	26550	15850	25	8400	26550	21800
4850	18250	11650	30	4850	18250	16500
2850	13450	8950	35	2850	13450	13200
1450	10200	6900	40	1450	10200	10200
	8050	5400	45		8050	8050
	6000	3800	50		6000	6000
	3350	1800	60		3350	3350

and set

k areas

										LATTICE EXTENSION WITH 101 FOOT BOOM		LATTICE EXTENSION WITH 114 FOOT BOOM			
88		101			114			134			147				
RATED LOAD POUNDS		LOADED BOOM ANGLE Δ°	RATED LOAD POUNDS		LOADED BOOM ANGLE Δ°	RATED LOAD POUNDS		LOADED BOOM ANGLE Δ°	RATED LOAD POUNDS		LOADED BOOM ANGLE Δ°	RATED LOAD POUNDS		LOAD RADIUS (FEET)	
380°	FRONT		360°	FRONT		360°	FRONT		380°	FRONT		380°	FRONT		380°
														10	
														12	
														15	
														20	
51000	51000	79	47000	47000	80	33000	33000	SEE WARNING NOTES 1 AND 3		SEE WARNING NOTES 1 AND 3		SEE WARNING NOTES 1 AND 3		25	
43000	43000	76	39000	39000	78	29000	29000	80	18000	18000				30	
36800	36800	73	33200	33200	75	25000	25000	78	14000	14000	79	12000	12000	35	
28300	31900	70	28300	28600	73	22000	22000	76	12000	12000	77	11000	11000	40	
22000	27600	67	22000	24700	70	19000	19000	74	11000	11000	75	9700	9700	45	
17700	22200	64	17700	22000	67	16300	16300	71	10000	10000	73	9200	9200	50	
14100	17800	60	14100	17800	64	14100	14400	69	9200	9200	71	8500	8500	55	
11300	14500	57	11300	14500	61	11300	13400	67	8500	8500	69	7900	7900	60	
9400	12200	53	9400	12200	58	9400	11600	64	8000	8000	67	7400	7400	65	
7600	10100	49	7600	10100	55	7600	10100	62	7500	7500	65	6900	6900	70	
6300	8600	45	6300	8600	52	6300	8600	59	7000	7000	63	6500	6500	80	
3900	5800	36	3900	5800	45	3900	5800	54	6000	6000	58	5800	5800	90	
RADIUS BOOM AS		23	2300	3900	36	2300	3900	48	4500	5500	53	4300	4900	100	
														110	
														120	
														130	

BOOM RATINGS MUST BE REDUCED BY WEIGHT OF BOOM ATTACHMENTS AND LOAD HANDLING DEVICES SEE TABLE

32R517

Minimum boom (75' maximum)

LOAD RATINGS WITHOUT OUTRIGGERS DEPEND ON TIRE CAPACITY AND CONDITION INFLATED PER TABLE AND APPLY ONLY WHEN REAR AXLE LOCKOUTS ARE ENGAGED

RATINGS FOR MANUAL BOOM		
STATIONARY 360°	OVER FRONT	
	STATIONARY & CREEP	2 1/2 MPH
45100	71700	55900
36300	63100	47900
27200	53300	38900
16700	41100	28700
10400	31500	21900
6400	21600	17000
3800	15800	13600
2000	11900	10900
—	6900	6900
—	5100	5100
—	3800	3800

TIRE INFLATION			
SIZE	STAT	CREEP	2 1/2 MPH
29.5x25-28 PR	75 PSI	75 PSI	65 PSI

WHEN TRANSPORTING A LOAD MACHINE MUST BE ON FIRM LEVEL SURFACE WITH MECHANICAL HOUSELOCK ENGAGED AND LOAD CENTERED OVER FRONT OF MACHINE AND RESTRAINED FROM SWINGING DO NOT EXCEED 2 1/2 MPH (4 KMPH) VEHICLE SPEED
CREEP IS MOTION FOR LESS THAN 200 FT IN A 30 MIN PERIOD AND NOT EXCEEDING 1 MPH

RATINGS ABOVE THE HEAVY LINE ARE BASED ON STRUCTURAL COMPETENCE AND NOT ON MACHINE STABILITY
STABILITY RATINGS DO NOT EXCEED 85% OF TIPPING LOADS WITH AUXILIARY SHEAVE ON BOOM POINT AND STOWED BOOM EXTENSION

32U1782

LOAD AT RADIUS SHOWN
TIPPING WILL OCCUR

Jib ratings

MAXIMUM JIB LOAD RATINGS IN POUNDS				
MINIMUM BOOM ANGLE	JIB LENGTH IN FEET			
	15	25	35	
0° OFFSET	80°	9100	7500	5000
	75°	7850	6500	4400
	70°	6650	5500	3900
	65°	5500	4500	3200
	60°	4550	3700	2600
	55°	3400	2900	2000
12.5° OFFSET	80°	8100	6200	4500
	75°	7050	5500	3600
	70°	5700	4500	3000
	65°	4700	3700	2450
	60°	3950	3100	2000
	55°	3200	2500	1500
25° OFFSET	80°	7300	5400	4000
	75°	5950	4500	3200
	70°	4700	3600	2500
	65°	3800	2900	2000
	60°	3250	2500	1500
	55°	2850	2200	1000

JIB CAPACITY NOTES:

- 1 MAXIMUM JIB LOAD RATINGS ARE BASED ON STRUCTURAL COMPETENCE AND DO NOT EXCEED 85% OF TIPPING LOAD WITH FULLY EXTENDED OUTRIGGERS USE OF OUTRIGGERS IS REQUIRED WHEN BOOM IS EQUIPPED WITH JIB
- 2 FOR BUCKET RATINGS ON JIB DEDUCT 20% FROM MAXIMUM JIB LOAD RATINGS
- 3 WARNING: DO NOT LIFT WITH JIB AT BOOM ANGLES BELOW 55° LOSS OF STABILITY OCCURS RAPIDLY
- 4 WARNING: DO NOT EXCEED 120 FOOT LOAD RADIUS WITH ERECTED 15 25 OR 35 FOOT JIB OR A TIPPING CONDITION WILL OCCUR

HOIST LINE WIRE ROPE		
TYPE	¾ - 8 x 19 IWRC	P&H TYPE 25 ¾ - 6 x 25F IWRC
BREAKING STRENGTH	51 800	58 800
PERMISSIBLE STRENGTH	14 800	16,800

PERMISSIBLE HOIST LINE LOAD IN POUNDS	
PARTS OF LINE	F & H #18 MAIN OR AUXILIARY WINCH
1	12,000
2	24,000
3	36,000
4	48,000
5	60,000
6	72,000
7	84,000
8	96,000
9	108,000
10	120,000
11	132,000

VEHICLE WEIGHTS: Include standard engine, standard manual boom (forward in travel position) standard main winch and optional auxiliary winch 690 (210 m) of 3/4" (19 mm) cable on main winch and 500' (152 m) of 3/4" (19 mm) cable on auxiliary winch standard tires 100 gals. fuel but less counterweight,

G V W	Front Axle	Rear Axle
85 015 (38 555 kg)	+ 52 006 (23 585 kg)	+ 33 009 (14 970 kg)

Effect on axle loads by adding these items:

9000 lb counterweight (std.)	9010 (4086 kg)	-- 4752 (2155 kg)	+13 762 (6241 kg)
55 ton hook block (stowed midship)	1200 (544 kg)	+ 1239 (562 kg)	+ 39 (18 kg)
Full powered boom (incl. cylinder and hose loop)	2224 (1009 kg)	+ 2704 (1226 kg)	- 480 (217 kg)
Boom extension (stowed)	1110 (503 kg)	+ 1683 (763 kg)	-- 573 (260 kg)
20 ton hook block (stowed midship)	600 (272 kg)	+ 620 (281 kg)	- 20 (9 kg)
8.5 ton weighted hook (stowed midship)	300 (136 kg)	+ 310 (141 kg)	- 10 (5 kg)
Auxiliary sheave	150 (68 kg)	+ 438 (199 kg)	- 288 (131 kg)

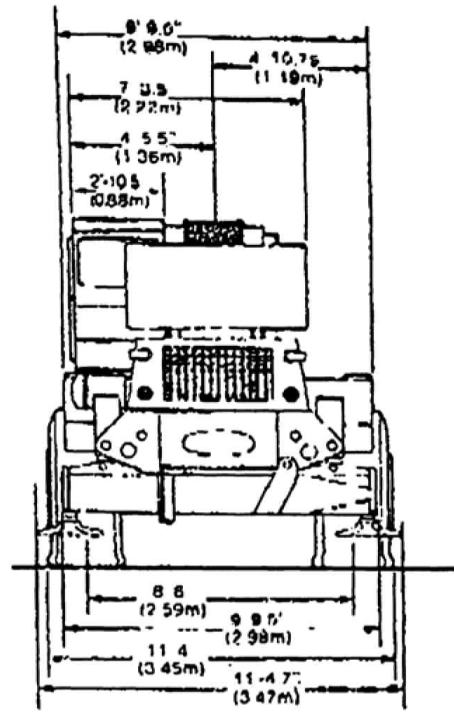

general dimensions

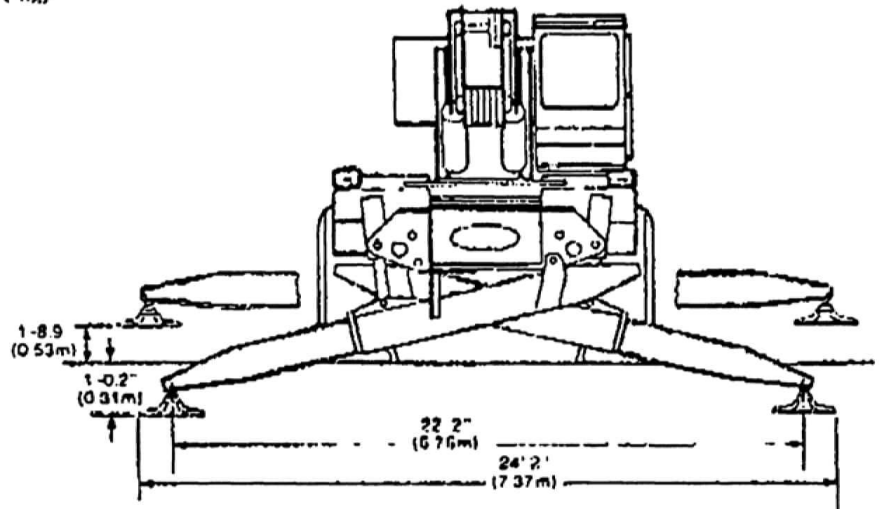

VEHICLE TURNING CIRCLE - WHEEL STEER CRAMP 47.5 (14.45m)
FRONT AXLE STEER 85.6 (26.05m)
VEHICLE CLEARANCE CIRCLE - WHEEL STEER CRAMP 54.9 (16.69m)
FRONT AXLE STEER 90.5 (27.56m)

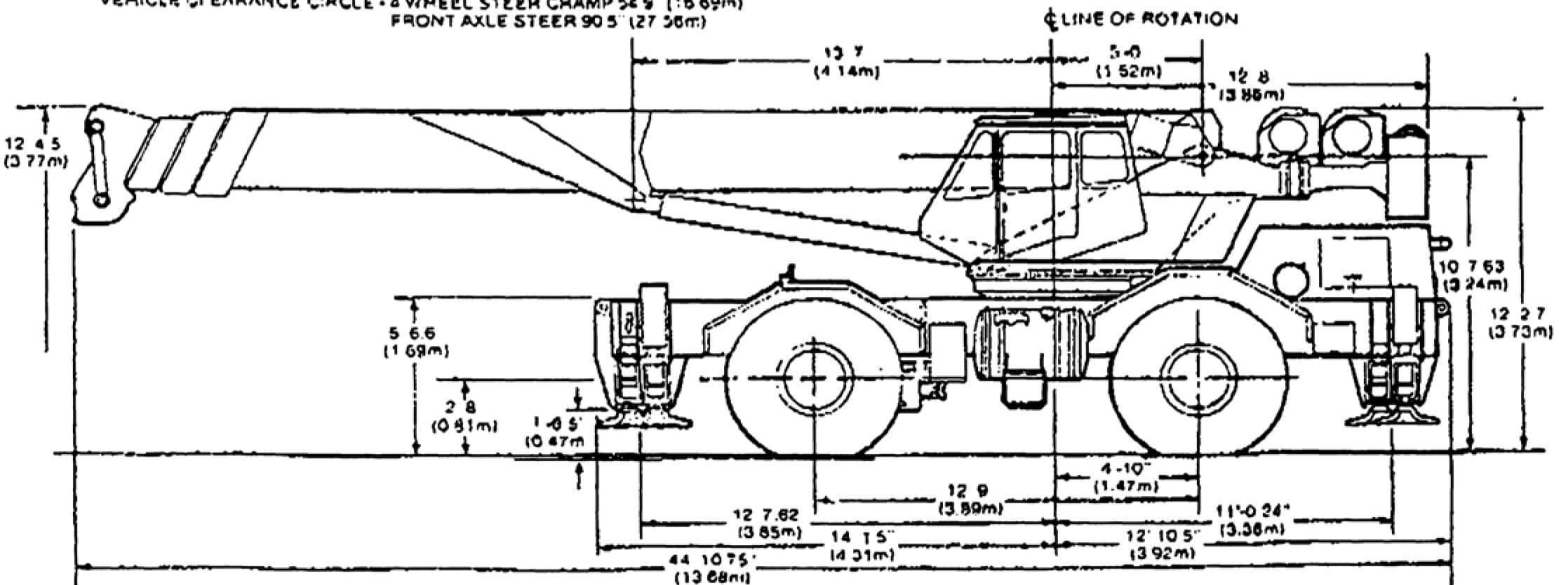

DRAWING NO 105J1277

Courtesy of Crane.Market