

PK 10000

Performance

PALFINGER



HIGH-PERFORMANCE AND COST-EFFICIENT



BEST RATIO OF WEIGHT TO LIFTING CAPACITY IN ITS CLASS

The PK 10000 *Performance* – the perfect crane for general duty! Because of its maximum ratio of weight to lifting capacity – the leading performance in this metre-tonne class – and its practical equipment specification, it becomes your perfect working unit.

The use of high-strength fine-grained structural steel and the new hexagonal boom profile make it possible to have an enormous hydraulic outreach of 12.4 m.



ENORMOUS HYDRAULIC OUTREACH THROUGH INNOVATIVE DESIGN AND CONSTRUCTION

Return oil utilisation

The high speed of the extension system is impressive. It results from return oil utilization feature which is installed as standard, and the generously dimensioned hydraulic pipes. This makes for increased efficiency during all types of working!



Load-holding valves

They prevent the crane boom from dropping and are fitted as standard on all cylinders. The valves are positioned in such a way that they are protected from damage.



Ergonomic crane control

The operating levers for all crane functions are ergonomically arranged on the console. This provides comfortable, efficient working. The control console is mounted so that it is easy to service.



Electronically assured safety

The optional PALTRONIC 50 electronic control system is a real advance in safety and convenience.

Hydraulic overload safety device

Also available as an option is the hydraulic overload safety device. In the event of overloading it immediately blocks any movements which would increase the load moment.

Radio control

The optional PALFINGER radio control system with digital data transmission ensures maximum safety and convenience. The display which is integrated in the control console informs the crane operator continuously about the current capacity status of the crane.

In combination with the PALFINGER radio control system, the load sensing proportional valve enables the crane to be adjusted with great sensitivity.

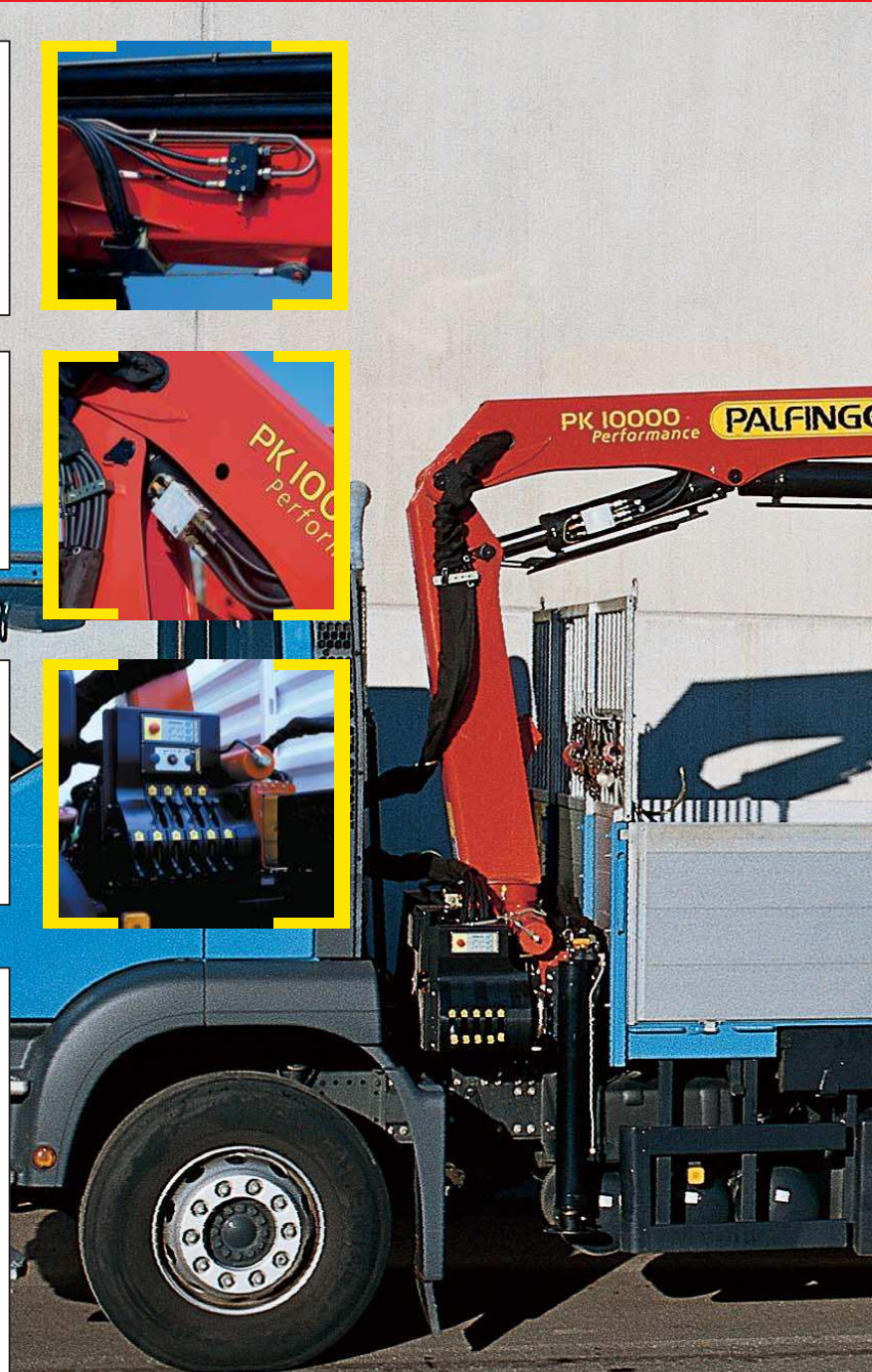
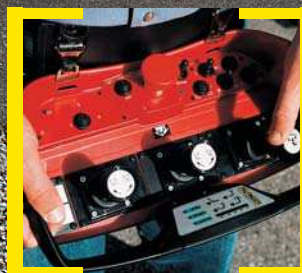

COMFORTABLE WORKING THANKS TO THE EQUIPMENT



Hose equipment for accessories

This option provides the oil supply for accessories. The hoses are routed in compact hose troughs and are therefore well protected.

Internally routed oil ducts

The internally routed oil passages make it possible to have a compact design for the extension system and ensure perfect protection from damage.

Central lubrication

For all bearings in the base frame.

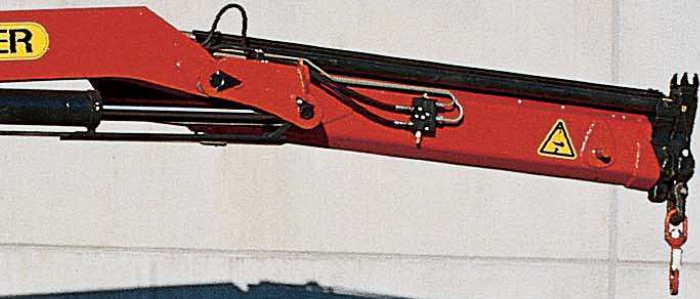

Extension system

- The extension cylinders are guided by using Jordal rails and rollers.
- Optimal height compensation of the extension cylinders



Large outrigger widths

The PK 10000 *Performance* fits on all standard truck chassis. Three stabiliser spreads are possible: 3.3 m (mechanical), 4.9 m (mechanical or alternatively hydraulic) and 5.6 m (hydraulic).

TECHNICAL DATA

Max. lifting capacities

PK 10000 Performance			
hydraulic			
Max. lifting capacities		5700 kg	12570 lbs
Outreach		Capacity	
4.4 m	14' 5"	2160 kg	4760 lbs
6.1 m	20' 0"	1570 kg	3460 lbs

PK 10000 Performance A			
hydraulic			
Max. lifting capacities		5580 kg	12300 lbs
Outreach		Capacity	
4.4 m	14' 5"	2080 kg	4590 lbs
6.1 m	20' 0"	1490 kg	3280 lbs
8.0 m	26' 3"	1120 kg	2470 lbs

PK 10000 Performance B			
hydraulic			
Max. lifting capacities		5460 kg	12040 lbs
Outreach		Capacity	
4.4 m	14' 5"	2010 kg	4430 lbs
6.1 m	20' 0"	1410 kg	3110 lbs
8.0 m	26' 3"	1030 kg	2270 lbs
10.1 m	33' 2"	800 kg	1760 lbs
manual			
12.4 m	40' 8"	490 kg	1080 lbs
14.4 m	47' 3"	380 kg	840 lbs
16.4 m	53' 10"	300 kg	660 lbs

PK 10000 Performance C			
hydraulic			
Max. lifting capacities		5360kg	11820 lbs
Outreach		Capacity	
4.4 m	14' 5"	1950 kg	4300 lbs
6.1 m	20' 0"	1340 kg	2950 lbs
8.0 m	26' 3"	950 kg	2090 lbs
10.1 m	33' 2"	720 kg	1590 lbs
12.2 m	40' 0"	590 kg	1300 lbs
manual			
14.3 m	46' 11"	350 kg	770 lbs
16.3 m	53' 6"	280 kg	620 lbs

The outreaches stated are with a boom angle of 20° and are therefore not the maximum.

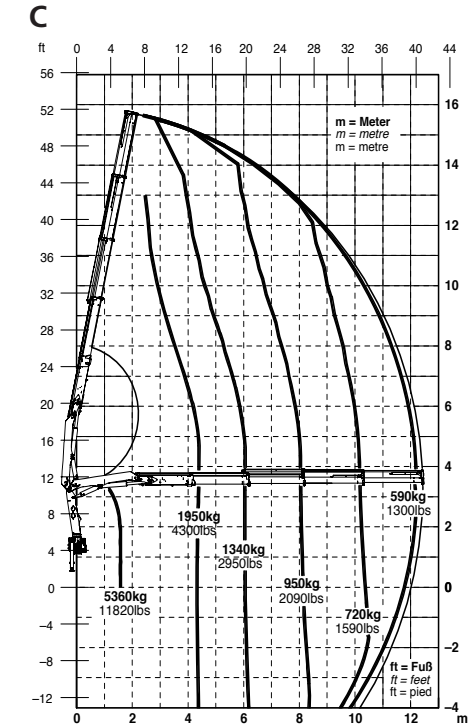
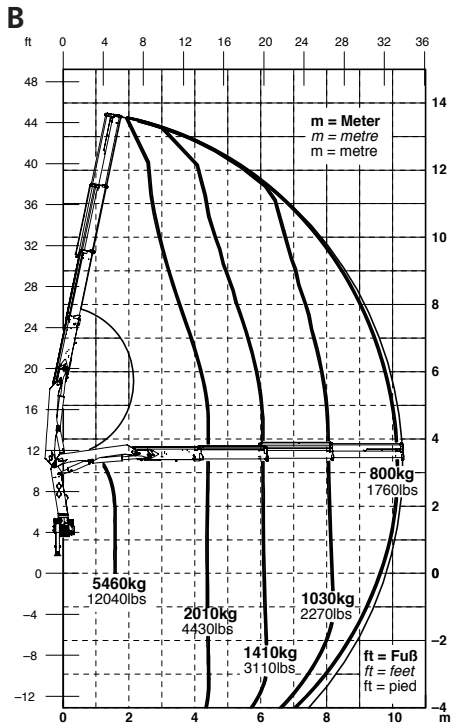
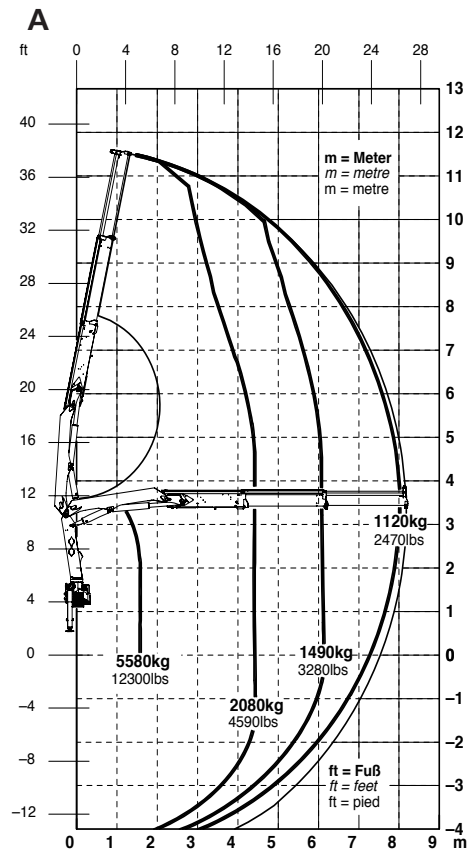
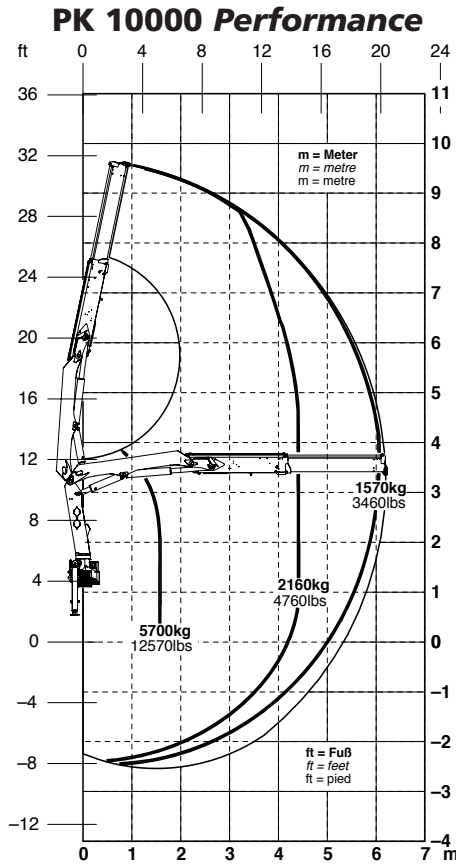

PALFINGER PERFORMANCE – FOR PERFORMANCE AND SAFETY

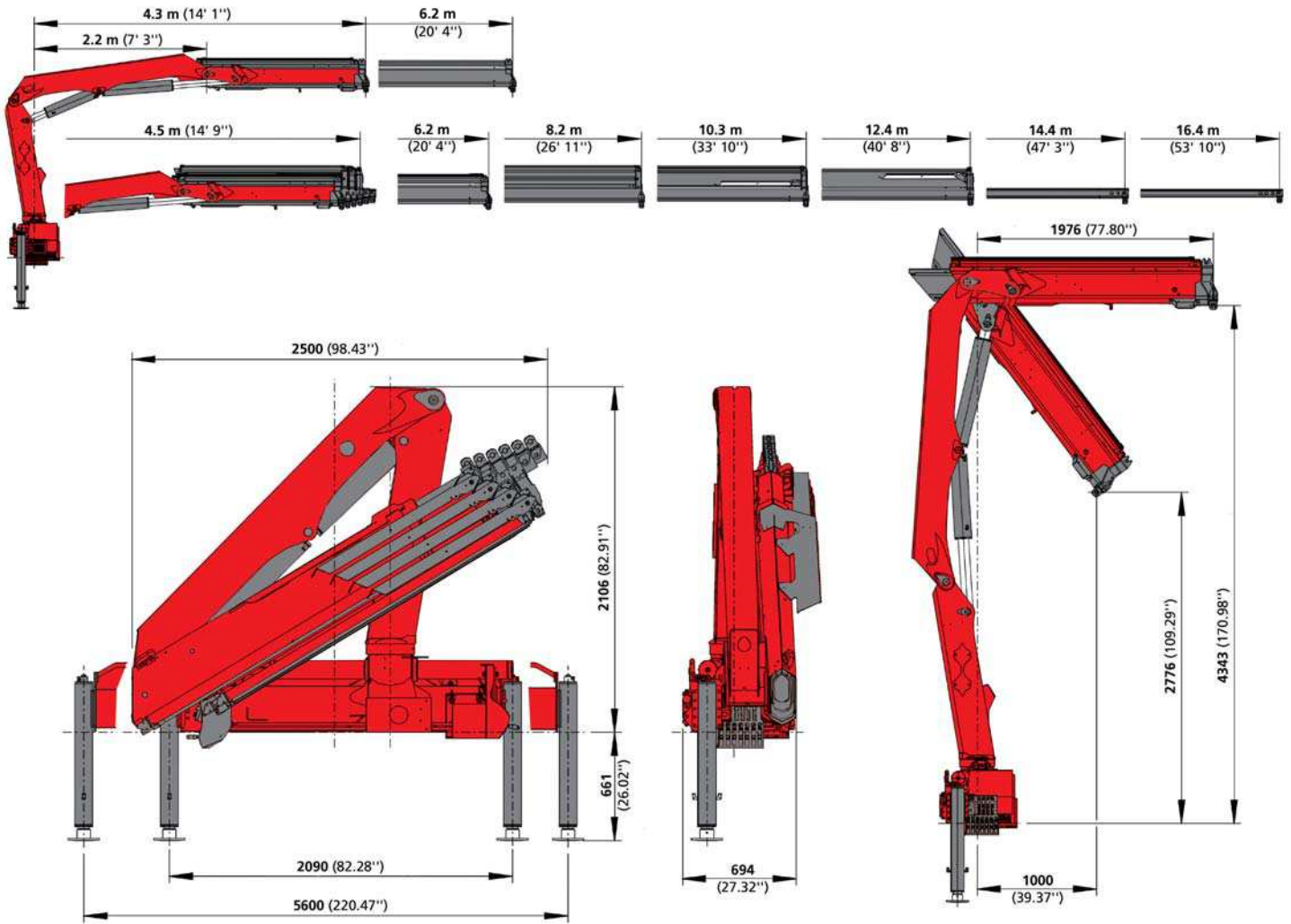

PK 10000 Performance		
Technical Specifications (EN 12999 H1-B3)		
Max. lifting moment	9.5 mt/93.5 kNm	68940 ft.lbs
Max. lifting capacity	5700 kg/55.9 kN	12570 lbs
Max. hydraulic outreach	12.4 m	40' 8"
Max. manual outreach	16.2 m	53' 2"
Slewing angle	400°	

PK 10000 Performance		
Standard crane		
Slewing torque	1.2 mt/11.8 kNm	8700 ft.lbs
Outreach	6.2 m	20' 4"
Stabilizer spread standard	3.3 m	10' 9"
Stabilizer spread max.	5.6 m	18' 4"
Fitting space required	0.70 m	2' 4"
Width folded	2.5 m	8' 2"
Max. operating pressure	315 bar	4568 psi
Recommended pump capacity	from 6.6 imp.gal./min 7.9 US gal./min to 9.9 imp.gal./min 11.9 US gal./min	
with radio remote control and LS-System	from 9.9 imp.gal./min 11.9 US gal./min to 13.2 imp.gal./min 15.9 US gal./min	
Dead weight standard crane	1031 kg	2270 lbs

Applications shown in the leaflet do not always correspond to the standard specifications. Design and specification are subject to change without prior notice.



Country-specific regulations must be considered for the crane installation.

www.palfinger.com

KP-PK10000M1+E, 10/07

Courtesy of Crane.Market