

gru_truck cranes

www.pesci-cranes.com



PESCI

SE 78

QUALITY

gru_truck cranes



- > Scheda tecnica
- > Fiche technique
- > Technische daten
- > Technical features
- > Ficha tecnica
- > Folha de dados



V. EMILIA 281 _ 48014 CASTEL BOLOGNESE (RA) _ ITALY
Tel +39.0546.653.833 _ Fax +39.0546.656.205
e-mail: info@pesci-cranes.com _ www.pesci-cranes.com

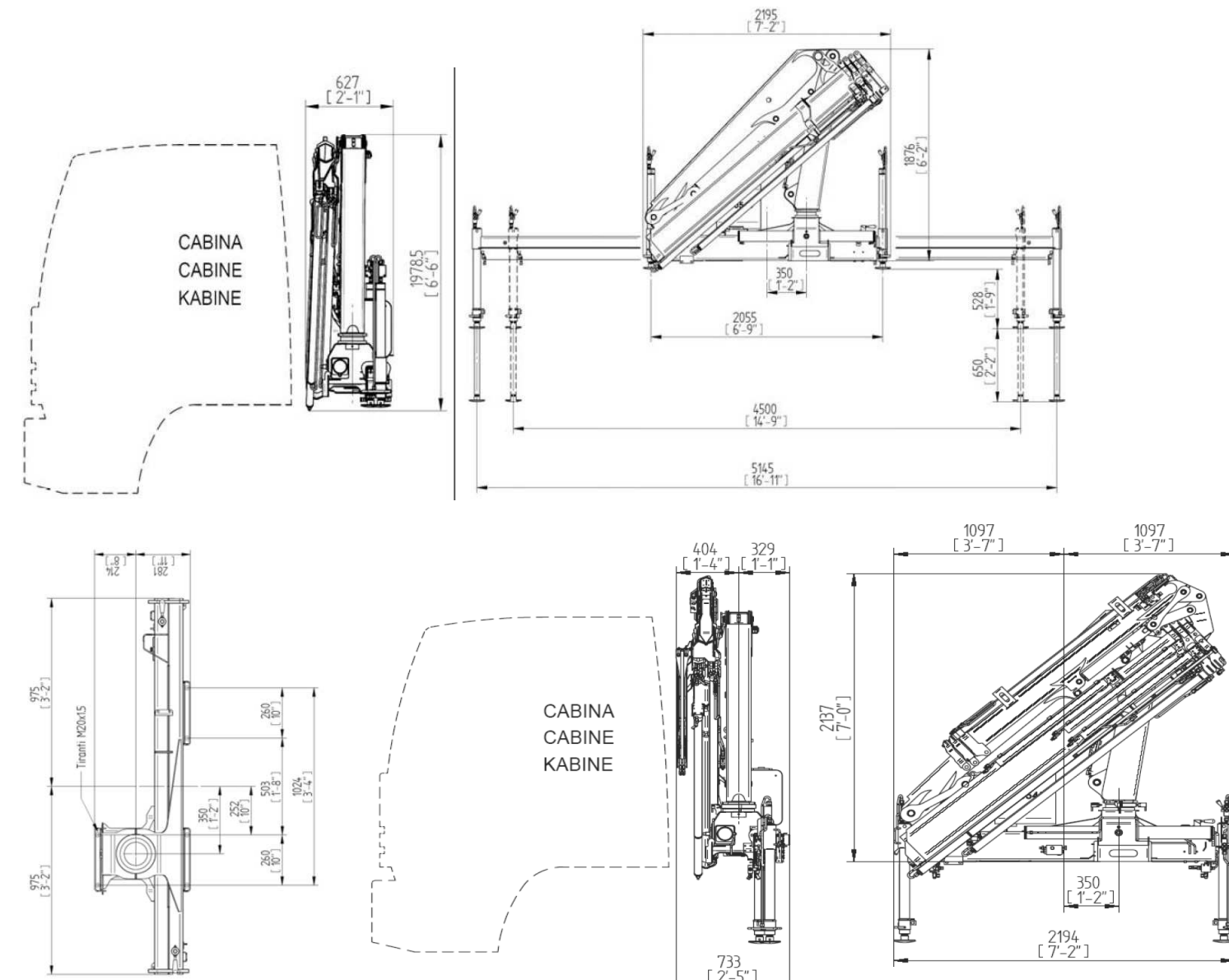
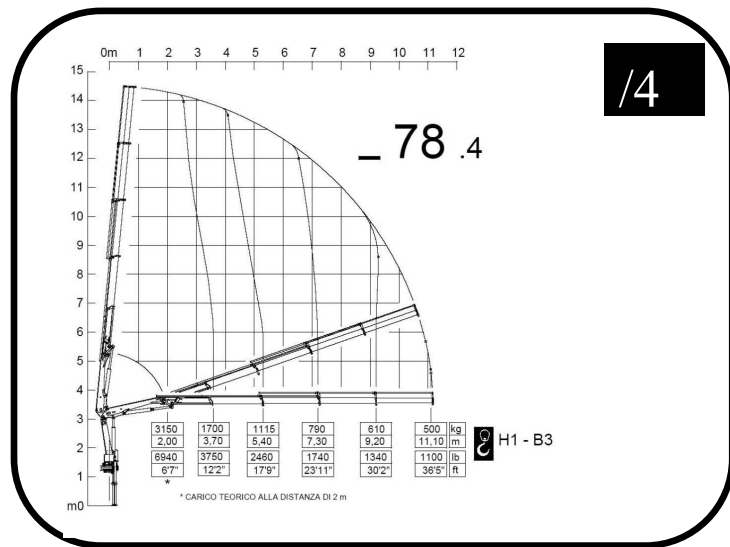
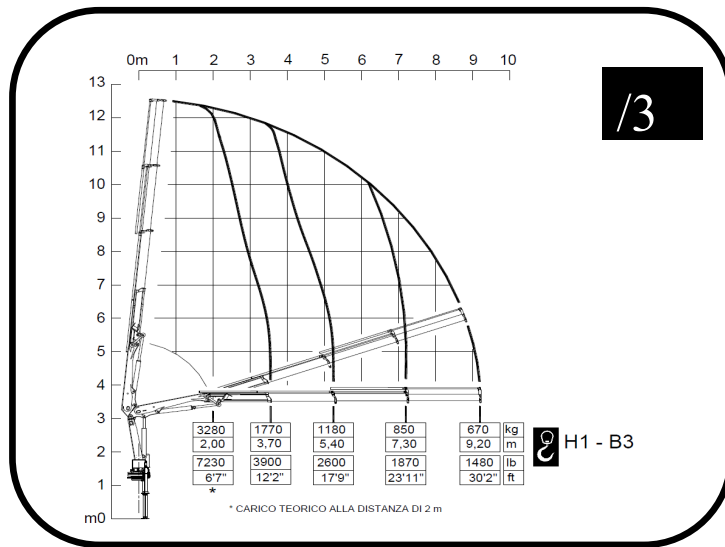
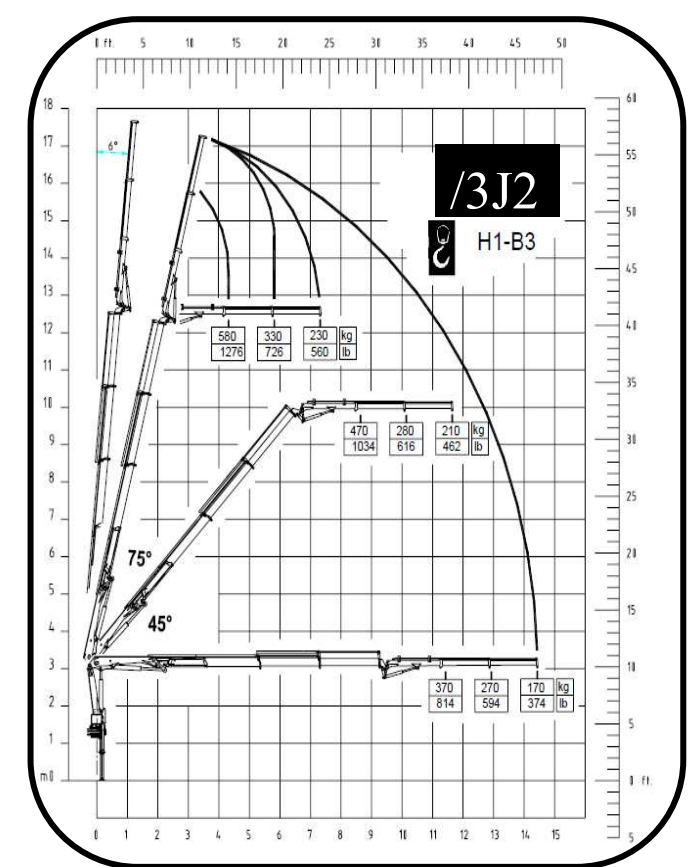
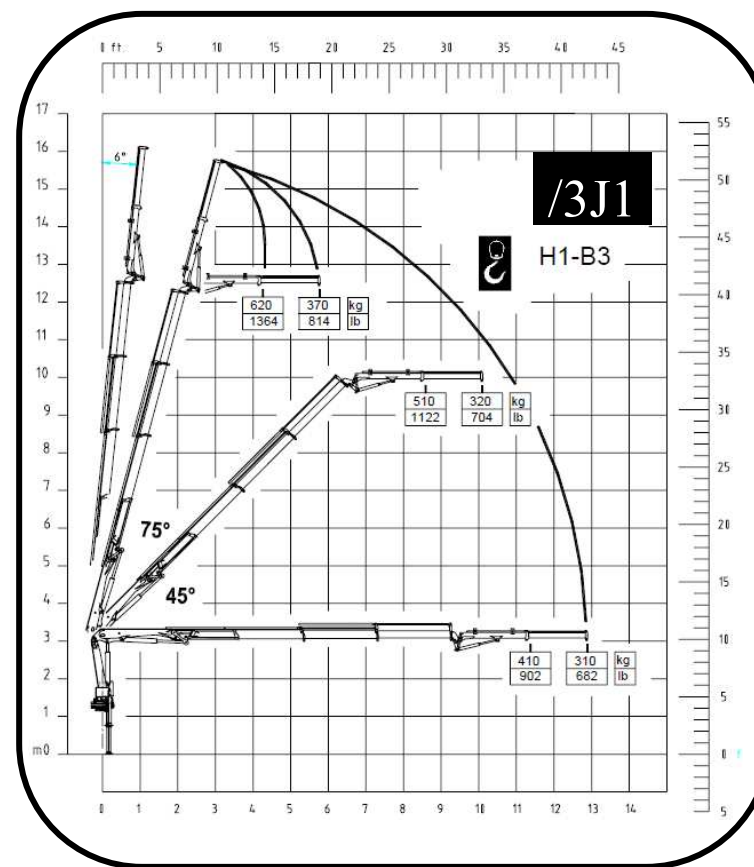
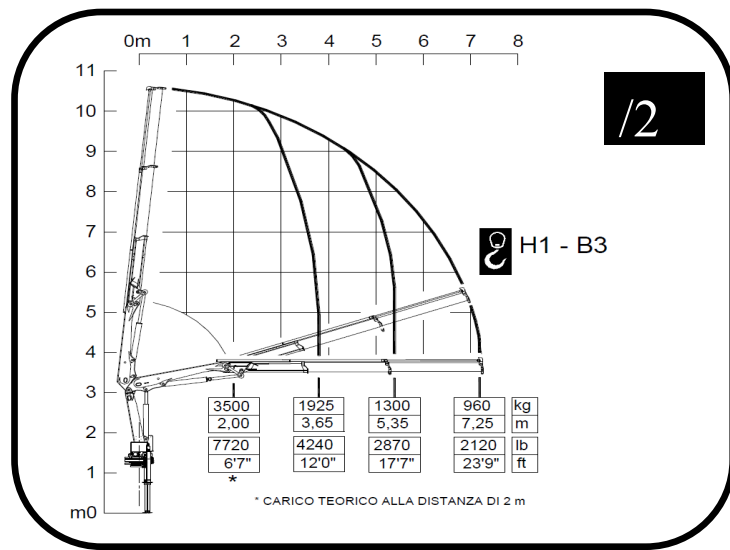
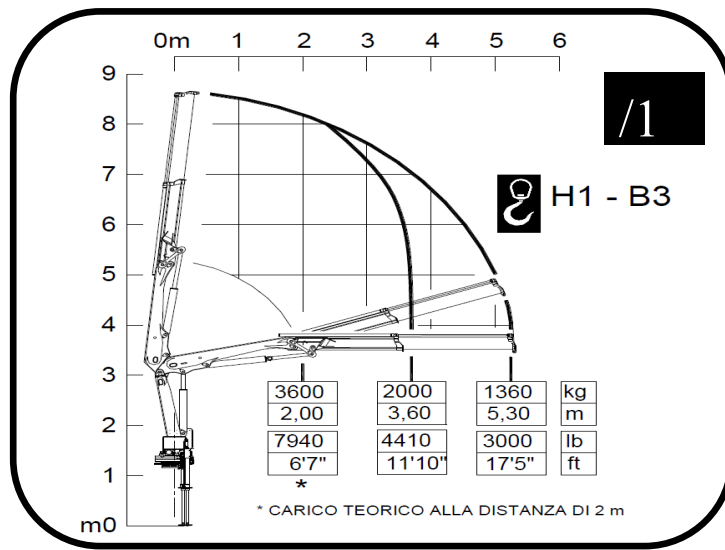

	/1	/2	/3 /3J1 /3J2	/4		/1	/2	/3 /3J1 /3J2	/4
- MOMENTO MAX SOLLEVAMENTO - HUBMOMENT - COUPLE DE LEVAGE - MOMENTO - MOMENTO - MAX LIFTING MOMENT	70,6 kN.m 51065 lbs.ft	68,93 kN.m 41445 lbs.ft	64,25 kN.m 46470 lbs.ft	54 kN.m 3906 lbs.ft	- PORTATA POMPA OTTIMALE - FÖRDERMENGE DER PUMPE - PORTÉE DE LA POMPE - CAUDAL DE LA BOMBA - CAUDAL DA BOMBA - RECOMMENDED PUMP DELIVERY	25 l/m 6,6 gal/min	20 l/m 5,3 gal/min	20 l/m 5,3 gal/min	20 l/m 5,3 gal/min
- ANGOLO DI ROTAZIONE - SCHWENKBEREICH - ROTATION - GIRO - ROTAÇÃO - SLEWING ANGLE	370°	370°	370°	370°	- CAPACITÀ SERBATOIO OLIO - FASSUNGSVERMÖGEN DEL ÖLBEHALTERS - CAPACITÉ RÉSERVOIR HUILE - CAPACIDAD DEL DEPOSITO DE ACEITE I - CAPACIDAD DO DEPÓSITO DE OLEO - OIL TANK CAPACITY	40 l 10,5 gal	40 l 10,5 gal	40 l 10,5 gal	40 l 10,5 gal
- COPPIA MAX ROTAZIONE - MAX SCHWENKMOMENT - COUPLE MAXI. DE ROTATION - POTENCIA MÁXIMA DE GIRO - BINARIO MÁXIMO DE ROTAÇÃO - SLEWING TORQUE	900 daN.m 6510 Psi	900 daN.m 6510 Psi	900 daN.m 6510 Psi	900 daN.m 6510 Psi	- VEICOLO MIN. P.T.T. - LKW MIN. G.G.W. - CAMION MIN. P.T.A.C. - CAMION PESO MIN. P.T.T. - P.B. MIN CAMION - TRUCK MIN. G.V.W	7,5 t	7,5 t	7,5 t	7,5 t
- PRESSIONE MAX LAVORO - DRUCK - PRESSION - PRESSÃO - MAX WORKING PRESSURE	300 bar 4350 Psi	300 bar 4350 Psi	300 bar 4350 Psi	300 bar 4350 Psi	- PESO GRU - GEWICHT - POIDS - PESO - PESO - CRANE WEIGHT	800 kg 1765 lbs	840 kg 1850 lbs	/3 970 /3j1 1070 /3j2 1100 kg /3 2050 /3j1 2360 /3j2 2430 lbs	960 kg 2070 lbs

I dati e le descrizioni del presente catalogo sono forniti a titolo indicativo e non sono vincolanti. PESCI si riserva il diritto di modificarli senza preavviso.
 Technical features are not binding. PESCI reserves itself the right to any modification without notice.