

GTMR 400 A

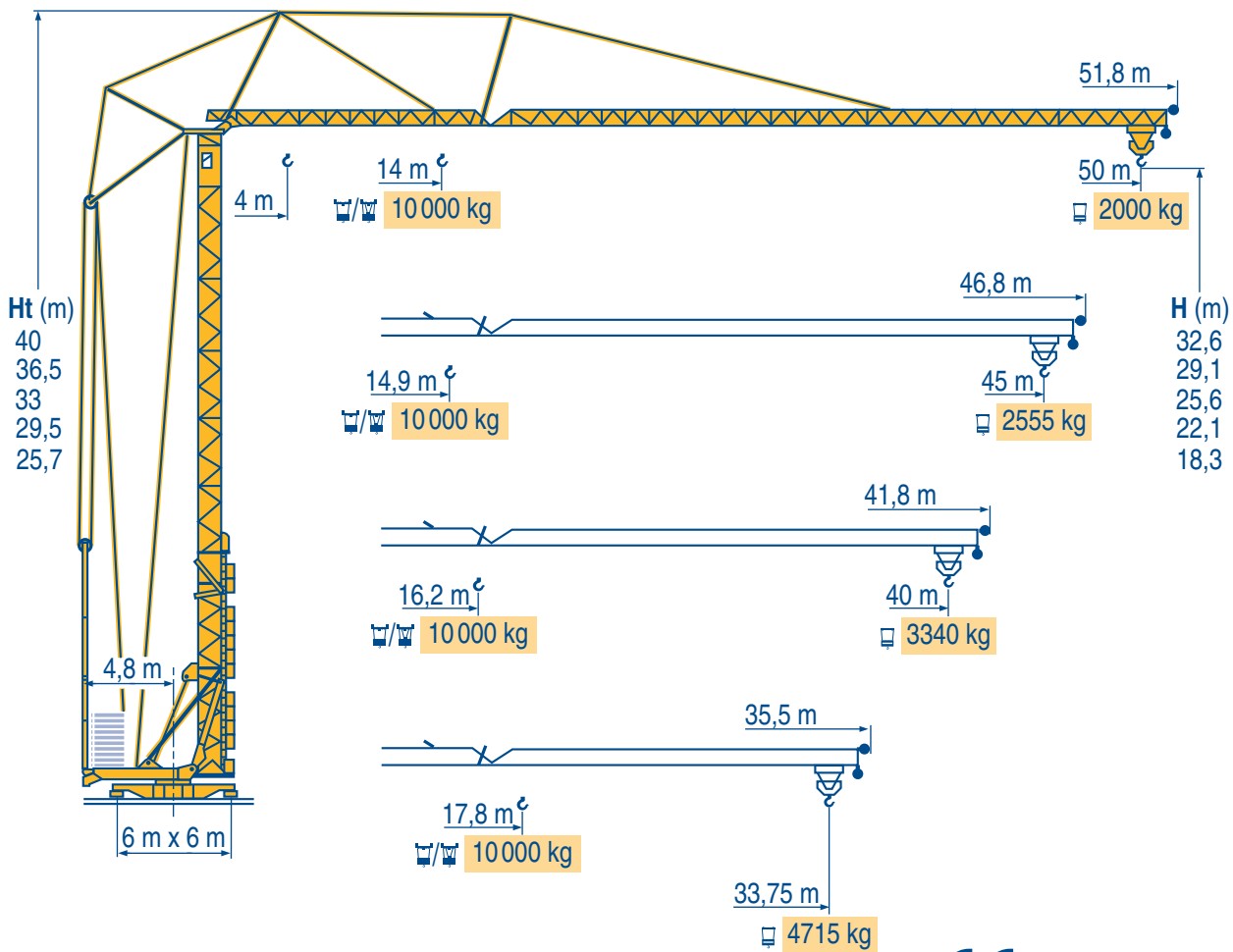

- Igo HD HDM
- HDT
- GTMR
- CITY CRANE
- TOPKIT MD MAXI MD
- MAXI TOPKIT
- Topless MDT
- MR

CE FEM 1.001-A3

LMU 2



Courbes de charges
Lastkurven



Load diagrams
Curvas de cargas



Curve di carico
Curva de cargas



50 m	4	▶	14	16	18	20	22	24	24,6	26	28	30	32	34	36	38	40	42	44	46	48	50	m
			10000	8370	7160	6230	5500	4900	-	4410	3990	3630	3330	3060	2820	2610	2430	2260	2110	1970	1850	1730	kg
			5000 4680 4260 3900 3600 3330 3090 2880 2700 2530 2380 2240 2120 2000 kg																				
45 m	4	▶	14,9	16	18	20	22	24	26	26,5	28	30	32	34	36	38	40	42	44	45	m		
			10000	9160	7850	6840	6040	5390	4860	-	4400	4020	3680	3390	3140	2910	2710	2530	2360	2290	kg		
			5000 4670 4290 3950 3660 3410 3180 2980 2800 2630 2560 kg																				
40 m	4	▶	16,2	18	20	22	24	26	28	28,9	30	32	34	36	38	40	m						
			10000	8730	7620	6740	6030	5440	4940	-	4510	4150	3830	3540	3290	3070	kg						
			5000 4780 4420 4100 3810 3560 3340 kg																				
33,75 m	4	▶	17,8	18	20	22	24	26	28	30	32	32,1	33,75	m									
			10000	9920	8670	7680	6880	6210	5650	5180	4760	-	4450	kg									
			5000 4720 kg																				

LMU 1

Réactions
Eckdrücke



Reactions
Reacciones



Reazioni
Reacções

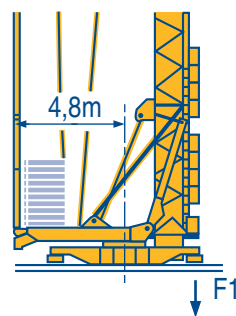

F1 ● 42,8 t ■ 28,6 t

40 t

LMU 1

●	Réactions en service		Reaktionskräfte in Betrieb		Reactions in service		Reacciones en servicio		Reazioni in servizio		Reacções em serviço	
■	Réactions hors service		Reaktionskräfte außer Betrieb		Reactions out of service		Reacciones fuera de servicio		Reazioni fuori servizio		Reacções fora de serviço	
	A vide sans lest (ni train de transport) avec flèche et hauteur maximum		Ohne Last, Ballast (und Transportachse), mit Maximalausleger und Maximalhöhe.		Without load, ballast (or transport axles), with maximum jib and maximum height.		Sin carga, sin lastre, (ni tren de transporte), flecha y altura máxima.		A vuoto, senza zavorra (ne assali di trasporto) con braccio massimo e altezza massima.		Sem carga (nem trem de transporte)-sem lastro com lança e altura máximas.	

Mécanismes
Antriebe



Mechanisms
Mecanismos



Meccanismi
Mecanismos



									ch - PS hp	kW
	33 TD PC 25	m/min	4,4	24	48	2,2	12	24	33	24
		kg	5000	5000	2500	10000	10000	5000		
	6 DPC 4	m/min	7,5 - 30 - 60						6	4,4
	RCO 58	tr/min U/min rpm	0,12 - 0,35 - 0,7						2 x 6,5	2 x 4,8
	Standard	m/min	12,5 - 25						2 x 5	2 x 3,7
CEI 38			IEC 38							
400 V (+6% -10%) 50 Hz				50 kVA			84/534 - 87/405			

LMU 1

	Levage		Heben		Hoisting		Elevación		Sollevamento		Elevação	
	Distribution		Katzfahren		Trolleying		Distribución		Distribuzione		Distribuição	
	Orientation		Schwenken		Slewing		Orientación		Rotazione		Rotação	
	Translation		Kranfahren		Travelling		Traslación		Traslazione		Translação	
	Conforme aux directives CEE 84/534 et 87/405 sur le niveau acoustique		Gemäss EWG-Richtlinien 84/534 und 87/405 für den Schall-Leistungspegel		In compliance with the EEC 84/534 and 87/405 Instructions on noise level		Conforme con las directivas CEE 84/534 y 87/405 sobre el nivel acústico		Conforme alle direttive CEE 84/534 e 87/405 sul livello acustico		Conforme as directivas CEE 84/534 e 87/405 sobre o nível acústico	

Montage
Montage



Erection
Montaje



Montaggio
Montagem

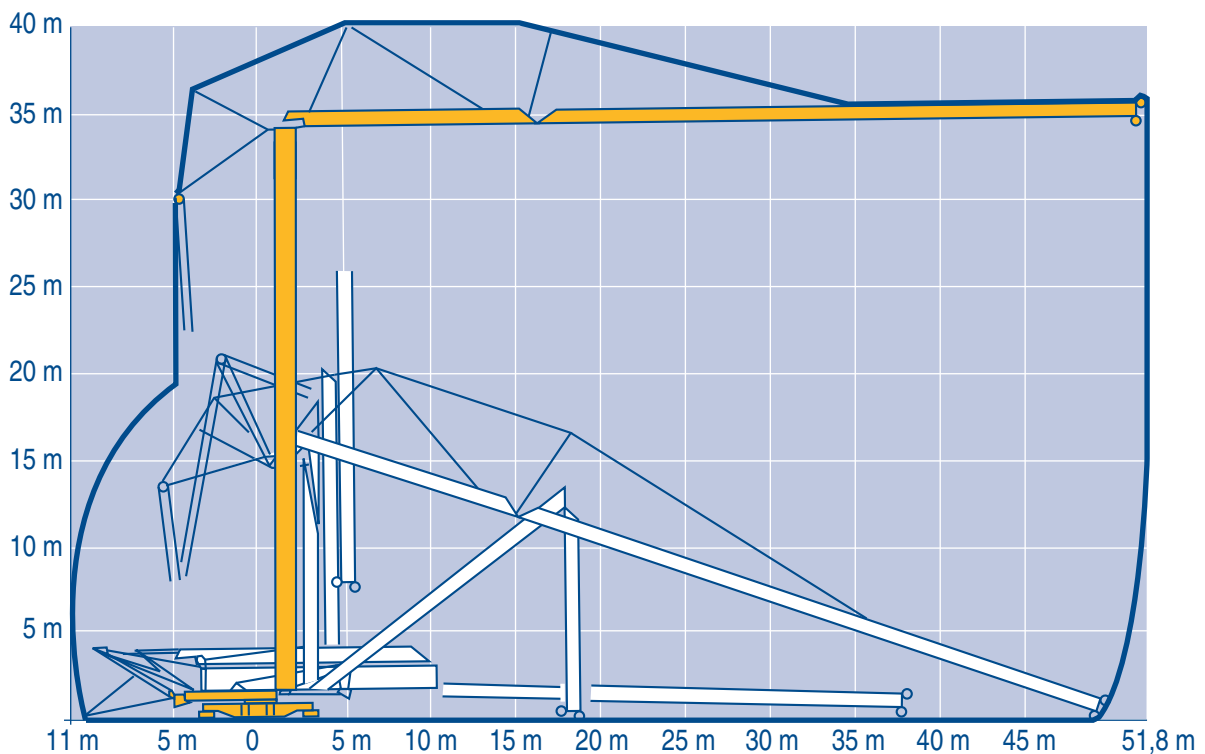

LMU 1

GTMR 400 A

POTAIN

Courtesy of Crane.Market

Transport
Version semi-portée

F

Transport
Tractor towed version

GB

Trasporto
Versione semi rimorchio

I

Transport
Ausführung als Sattelaufleger

D

Transporte
Versión en semi-remolque

E

Transporte
Versão rebocada

P

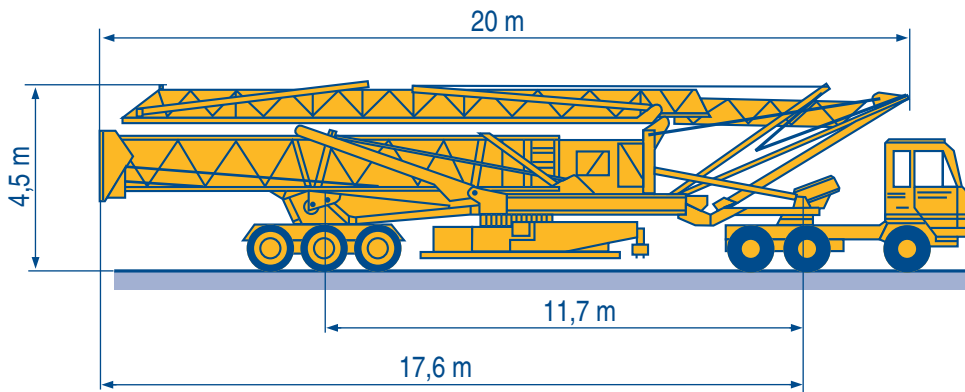

S6/121

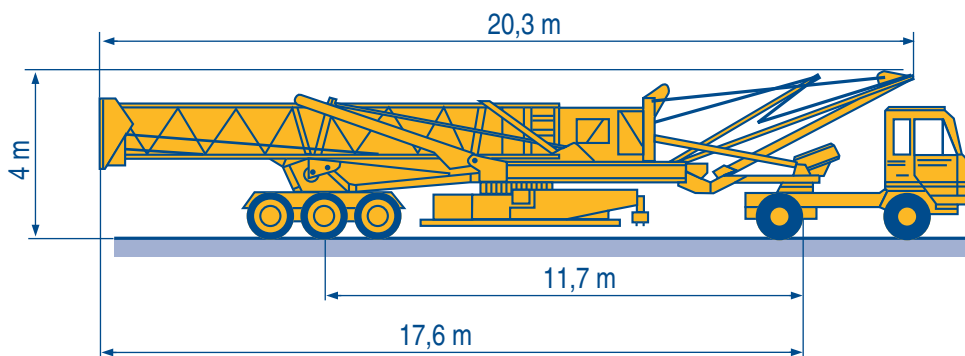

S6/121

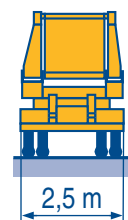

LMU 1



Document commercial non contractuel. Pour toute information technique se référer à la notice correspondante

Unverbindliches Vertriebsdokument. Für technische Informationen, siehe die entsprechenden Anweisungen.

This commercial document is not legally binding. For any technical information, please refer to the corresponding instructions.

Documento commercial non contractuel. Para cualquier información técnica, ver la noticia correspondiente.

Documento commerciale non vincolante, per tutte le informazioni tecniche fare riferimento al catalogo istruzioni

Documento comercial não contratual. Para qualquer informação técnica complementar consultar as respectivas instruções

POTAIN

18.Rue de Charbonnières, B.P. 173
F-69132 ECULLY Cedex
Tél. (33)04.72.18.20.20
Fax (33)04.72.18.20.00
<http://www.potain.com>
E-mail : mkt@potain.fr

Manitowoc

Manitowoc Crane Group

Deutschland

POTAIN GmbH

Tel : 06.1.05.70.40

Italia

POTAIN S.p.A.

Tel : 0.331.49.33.11

Portugal

POTAIN Portugal

Tel : 22.968.08.89

Singapore

MANITOWOC POTAIN PTE LTD

Tel : 227.15.50

Copyright.Reproduction interdite © POTAIN 2000

GTMR 400 A

Réf. 1999.44 LMU 7

Modifications réservées / Änderungen vorbehalten / Subject to modification / Modificaciones reservadas / Modifiche riservate / Reserva de modificaciones

Printed in France

Réalisation HeadLines

Courtesy of Crane.Market