

Mat / Réactions \square 1,6 m
 Maste /
 Eckdrücke 30 m \Rightarrow 60 m
 Masts /
 Reactions
 Mástil /
 Reacciones
 Torre / Reazioni
 Tramo /
 Reações

LZF 1

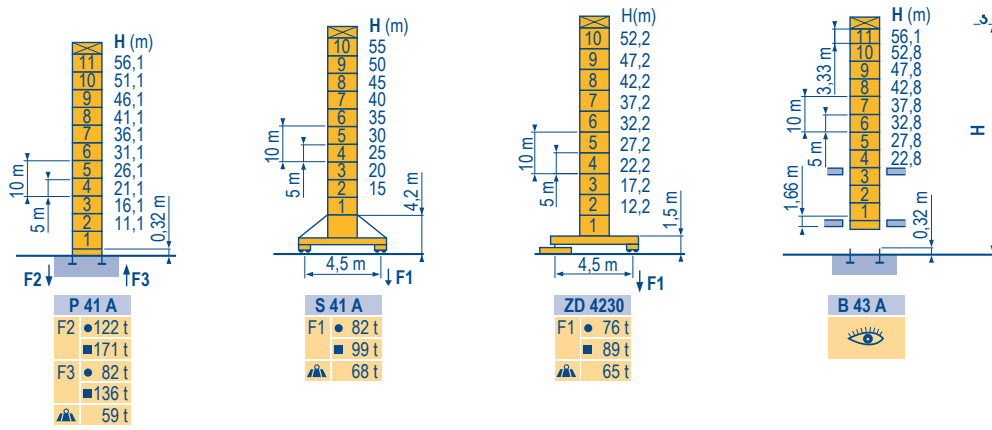

\square 2 m
 30 m \Rightarrow 60 m

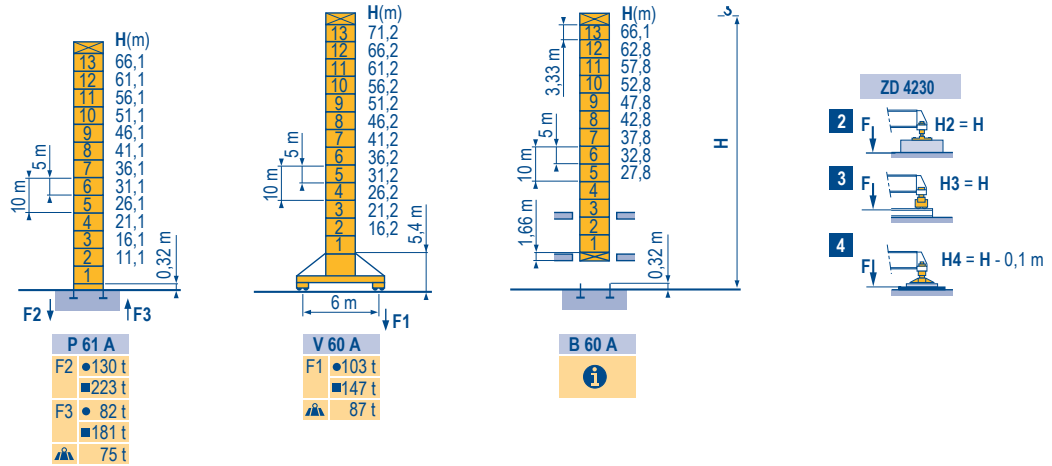

Télescopage sur dalles
 Kletterkrane im Gebäude
 Climbing crane
 Telescopage gruas trepadoras
 Gru in cavedio
 Telescopagem sobre lages

LZF 1

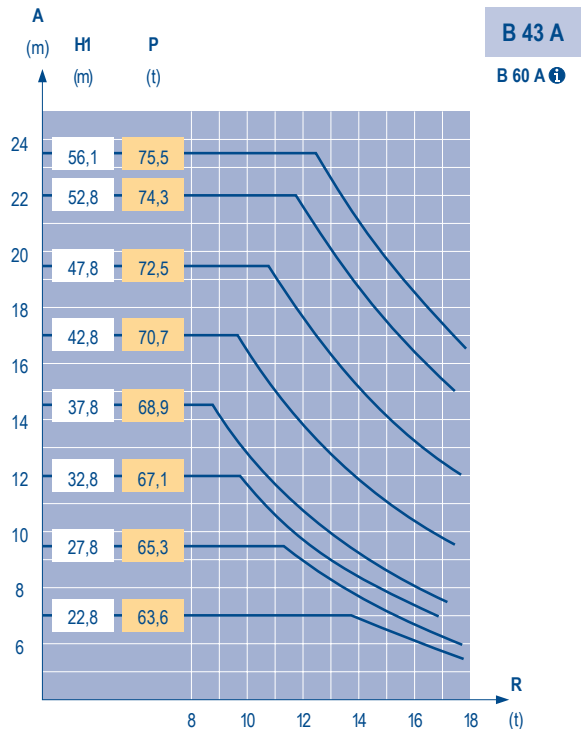
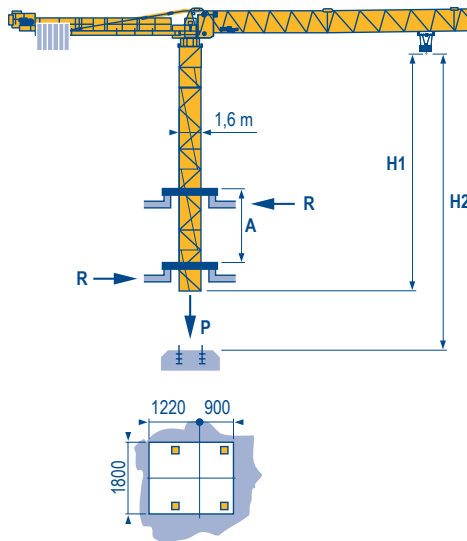

Topless
 MDT 162 H8

POTAIN

F	D	GB	E	I	P
● Réactions en service ■ Réactions hors service A vide sans lest (ni train de transport) avec flèche et hauteur maximum.	● Reaktionskräfte in Betrieb ■ Reaktionskräfte außer Betrieb Ohne Last, Ballast (und Transportachse), mit Maximalausleger und Maximalhöhe.	● Reactions in service ■ Reactions out of service Without load, ballast (or transport axes), with maximum jib and maximum height.	● Reacciones en servicio ■ Reacciones fuera de servicio Sin carga, sin lastre, (ni tren de transporte), flecha y altura máxima.	● Reazioni in servizio ■ Reazioni fuori servizio A vuoto, senza zavorra (ne assali di trasporto) con braccio massimo e altezza massima.	● Reações em serviço ■ Reações fora de serviço Sem carga (nem trem de transporte) - sem lastro com lança e altura máximas.
Nous consulter	Auf Anfrage	Consult us	Consultarnos	Consultateci	Consultar-nos

Courbes de charges

Lastkurven

Load diagrams

Curvas de cargas

Curve di carico

Curva de cargas

LZF 1

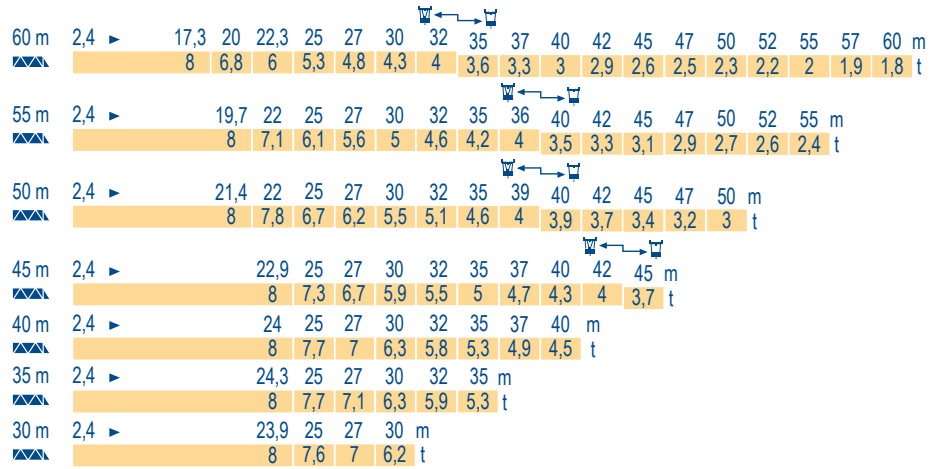

Lest de contre-flèche

Gegenauslegerballast

Counter-jib ballast

Lastre de contra flecha

Contrappeso

Lastros da contra lança

LZF 1

	3 150 kg - 2 100 kg	
	50 LVF 20	
		(kg)
60 m	16,5 m	15 750
55 m	16,5 m	15 750
50 m	16,5 m	15 750
45 m	16,5 m	14 700
40 m	16,5 m	13 650
35 m	16,5 m	12 600
30 m	16,5 m	11 550

Lest de base

Grundballast

Base ballast

Lastre de base

Zavorra di base

Lastros da base

LZF 1

Base	S 41 A - ●	H (m)	55	50	45	40	35	30	25	20	15			
			(t)	84	60	48	48	48	48	48	48	48		
1,6 m	ZD 4230 - ●	H (m)	52,2	47,2	42,2	37,2	32,2	27,2	22,2	17,2	12,2			
		(t)	70	55	50	50	50	50	50	50	50			
2 m	V 60 A - ●	H (m)	71,2	66,2	61,2	56,2	51,2	46,2	41,2	36,2	31,2	26,2	21,2	16,2
		(t)	132	108	84	60	36	36	36	36	36	36	36	36

Topless

MDT 162 H8



	F	D	GB	E	I	P
A	Distance entre cadres	Abstand zwischen den Rahmen	Distance between collars	Distancia entra marcos	Distanza fra i telai	Distância entre quadros
H1	Hauteur grue	Kranhöhe	Crane height	Altura grúa	Altezza gru	Altura da grua
P	Poids de la grue(en service)	Krangewicht (in Betrieb)	Crane weight (in service)	Peso de la grúa (en servicio)	Peso della gru (in servizio)	Peso da grua (em serviço)
R	Réaction horizontale	Horizontalkräfte	Horizontal reaction	Reaccion horizontal	Reazione orizzontale	Reacção horizontal
	Voir télescopage sur dalles	Siehe Kletterkrane im Gebäude	See climbing crane	Veja grua trepadora	Consultare gru in cavedio	Ver telescopagem sobre lages

Mécanismes
Antriebe
Mechanisms
Mecanismos
Meccanismi
Mecanismos

LZF 3

														ch - PS hp	kW					
	50 LVF 20 Optima	m/min	4 → 16 → 46 → 60 → 86 → 124							2 → 8 → 23 → 30 → 43 → 62					50	37	602 m			
		t	4	4	4	3	2	1	8	8	8	6	4	2						
	7 DVF 4	m/min	0 → 79														6,5	4,8		
	RVF 162 Optima +	tr/min U/min rpm	0 → 0,7														2 x 7,5	2 x 5,5		
	S 41 A RT 443 A1 2V R ≥ 10 m	m/min	15 - 30														4 x 5	4 x 3,7		
		ZD 4230 A RT 324 A1 2V	m/min	12,5 - 25														2 x 7	2 x 5,2	
	V 60 A RT 544 A1 2V R ≥ 13 m	m/min	13,5 - 27														4 x 7	4 x 5,2		
		CEI 38	IEC 38											kVA						
		400V (+6%-10%) 50 Hz											50 LVF 20 : 75 kVA							

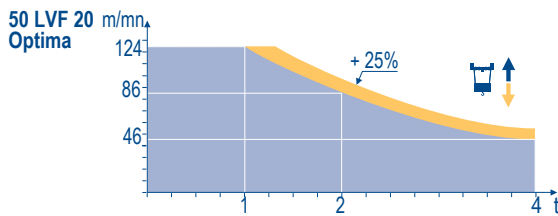

	F	D	GB	E	I	P
	Levage	Heben	Hoisting	Elevación	Sollevamento	Elevação
	Distribution	Katzfahren	Trolleying	Distribución	Distribuição	Distribuição
	Orientation	Schwenken	Slewing	Orientación	Rotazione	Rotação
	Translation	Kranfahren	Travelling	Traslación	Traslazione	Translação

Document commercial non contractuel. Pour toute information technique se référer à la notice correspondante. Unverbindliches Vertriebsdokument. Für technische Informationen, siehe die entsprechenden Anweisungen. This commercial document is not legally binding. For any technical information, please refer to the corresponding instructions. Documento comercial non contractuel. Para cualquier información técnica, ver la noticia correspondiente. Documento commerciale non vincolante, per tutte le informazioni tecniche fare riferimento al catalogo istruzioni. Documento comercial não contractual. Para qualquer informação técnica complementar consultar as respectivas instruções.



Americas
Tel : +1 888 479 7278
Tel : +1 717 593 2000

Europe – Middle East – Africa
Tel : +33 (0) 4 72 81 50 00
Tel : +44 (0) 191 522 2000

Asia – Pacific
Tel : +65 6264 1188
Fax : +65 6862 4142

www.manitowoccrane.com

**18, rue de Charbonnières - B.R.173
69132 ECULLY Cedex - France**
Tél. : +33 (0) 4 72 18 20 20
Fax. : +33 (0) 4 72 18 20 00
www.manitowoccrane.com

Topless MDT 162 H8
Réf. 2003 48 LZF 3
Copyright.Reproduction interdite © POTAIN 2003

Réalisation Sedoc