

SAC3500

SAC3500 ALL-TERRAIN CRANE
350 TONS LIFTING CAPACITY

Quality Changes the World

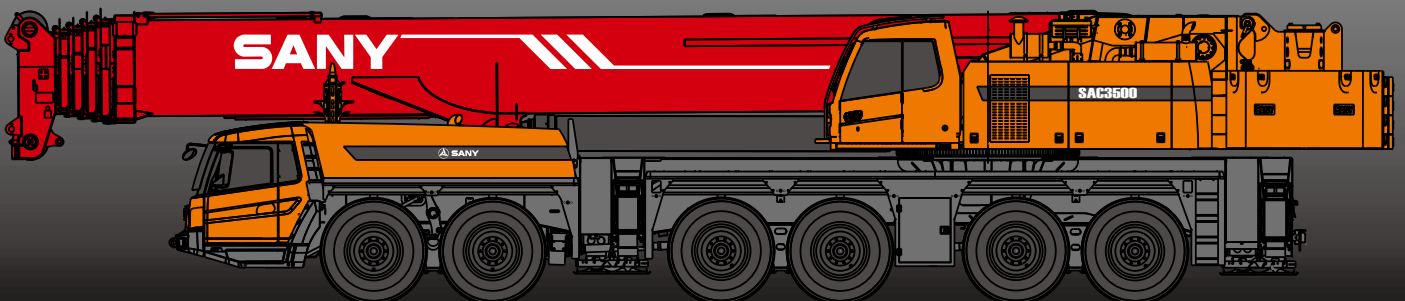

SANY

Courtesy of Crane.Market

■ SANY Automobile Hoisting Machinery is one of the core business unit of Sany Heavy Industry, mainly engaged in the research and development of high end, mid to large tonnage crane series, including mobile crane, crawler crane, tower crane and loader crane. It has two industrial parks in Ningxiang and Huzhou, since entering the market, the products of Sany Automobile Hoisting Machinery have received worldwide recognition with advanced technology, lean manufacturing, high reliability and excellent service.



SANY ALL-TERRAIN CRANE

CONTENT

- 04 Icon
- 05 Selling points
- 06 Introduction
- 11 Dimension
- 12 Technical Parameter
- 13 Operation Condition
- 15 Load Chart
- 46 Counterweight sketch Map
- 48 Wheel Crane Family Map



Excellent and stable chassis performance

The use of innovative 6-axle chassis design with six driving modes and four braking modes can provide more reliable traveling performance. High stability and safety are guaranteed with tipping over early-warning technology.

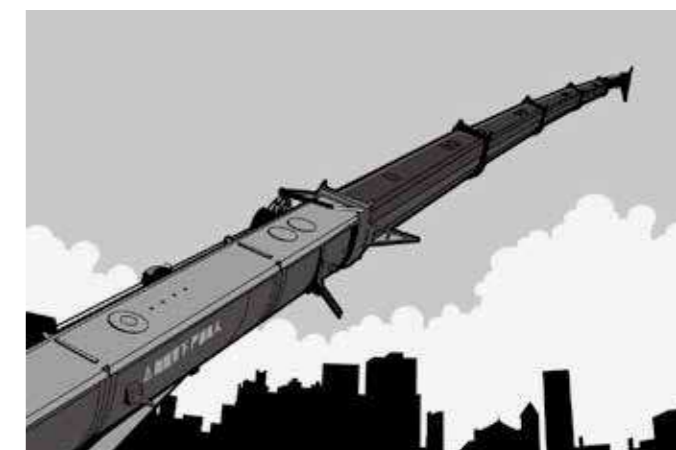

Ultra long Boom for Wide Working Radius

Longest boom length and luffing jib length is 70m and 78m respectively, which ensures Max. lifting height of 132m and working radius of 96m. 0°~40° automatic infinite variable luffing jib is applied, ensuring conveniently switching over between all operation with high efficiency.



Highly efficient, energy-saving and unique hydraulic control technology

Self-developed dual-pump converging / diversion main valve is used. Converging flow of the single-action dual-pump ensures fast operation and high work efficiency and combined-action dual-pump diversion system is applied to ensure stable controllability. Electric proportional variable displacement piston pump is used to ensure high-accurate flow control, higher efficiency and energy saving.





Safe, stable, advanced, and intelligent electronic control technology

The adoption of internationally advanced distributed integration bus data communication network and the configuration of the abundant sensing elements can achieve timely feedback of data information and monitor the overall working status in real-time. The human-computer interaction interface is adopted to meet customer's individual requirements.

Superstructure

-  **Cab**
- It is made of anti-corrosion steel plate with ergonomic design such as full-coverage soften interior, panoramic sunroof and adjustable seats etc., providing more comfortable and relaxing operation. The display of load moment limiter integrates main console and operation display system, which clearly show the data of all operating conditions for lifting operation.

-  **Engine**
- Type: Inline six-cylinder, water cooled, supercharged and inter-cooling diesel engine;
 - Rated power: 205kw/2200r/min;
 - Environment-protection: Emission complies with EuroIII standard;
 - Capacity of fuel tank: 400L.

-  **Hydraulic system**
- Open-closed combined independent hydraulic system is adopted for superstructure, which has the feature of load sensitive feature and high action efficiency with, low speed under heavy load, high speed under light load and high action efficiency. The luffing telescopic system adopts open system composed of electric proportional pump and self-control main valve. With four-level pressure selection function coordinated with the displacement of the electric proportional pump, different pressure grade is applied for different corresponding action, achieving energy-saving and safe luffing and telescopic actions. Lifting winch system adopts closed system to avoid throttling loss of the open system and ensure high efficiency and wide speed regulation range. Closed system is used for slewing operation to avoid throttling loss of the open system, thus ensuring high efficiency and good micro-mobility. In addition to the superstructure slewing, boom luffing, telescopic, lifting operations, the lifting of the counterweight, rotation of cab and locking of the rotating bed can be achieved as well.
 - The adoption of key hydraulic parts such as high-quality main oil pump, slewing pump, main valve, winch motor and balance valve etc. ensure high stability and reliability of the system. The electric proportional variable displacement piston pump is used to adjust the pump displacement in real-time through changing the opening of the electrical control handle, thus achieving high-precision flow control with no-loss of energy in operation. Self-developed dual-pump converging / diversion main valve is used with single-action dual-pump applied to ensure high converging efficiency and with combined-action dual-pump diversion to ensure good controllability.
 - The use of dead-weight luffing compensation hydraulic system ensures excellent lowering micro-mobility and stability.
 - Single-cylinder pin telescopic system is used for boom.
 - Jib is equipped with luffing cylinder to achieve 0°~40°infinite luffing.
 - Capacity of hydraulic oil tank: 1425L

-  **Control system**
- With 24V DC power supply, the PLC integrated programmable controller and CAN-bus control network are used to achieve logic control and electro proportional control of the system by combining with the common electricity.
 - With real-time monitoring and fault self-diagnosis system.
 - Lifting, slewing and luffing can be controlled by two auto-reset multidirectional electric proportional handles. Foot-type telescopic pedal is used for telescopic operation. Lifting of counterweight, shifting of cab and locking of rotating bed can be controlled through the keys on the control panel;
 - Display can be connected with the controller via CAN-bus with main functions as follows: digital adjustment and display of the electro proportional control parameters, display of fault code of the electro proportional system and real-time data display by the hydraulic system.

Superstructure

-  **Main boom**
- It consists of six section booms, welded with bended fine-grain high-strength steel plate, with oval section applied to ensure good buckling resistance performance. With single-cylinder automatic pin system, a dual-action cylinder can control telescopic operation of all booms and achieve a variety of boom combinations.
 - Basic boom length is 15.2m and fully extended boom length is 70m. Max. lifting height is 70m.

-  **Jib**
- There are fixed jib and tower jib. The adaptor, jib head and 6m and 12m large (small) sectional standard sections are shared by fixed jib and tower jib. 6m~42m boom combination can be achieved for fixed jib. The application of 0~40°infinite luffing jib improves automation level and working efficiency through changing the angle according to the actual demands of the operating condition. With tower jib, 12m~78m jib combination can be achieved, thus greatly improving lifting capacity and operating height.
 - The max lifting height of fixed jib is 112m and the max lifting height of tower jib is 132m.

-  **Luffing system**
- The top single-cylinder luffing is applied, with luffing angle ranging from -0.4° to 82°. Hydraulic system adopts the dual-pump converging open hydraulic circuit to achieve large-angle fast lowering and small-angle stable and slow lowering operations combining with electro proportional control, power lowering, and self-weight luffing.

-  **Superlift devices**
- They are arranged at left and right sides of basic boom head independently and can be self-assembled and self-disassembled without any auxiliary lifting. With superlift device, the stress applied on the lifting boom can be reduced to avoid side bending and to reduce down-warping deformation. Therefore, under long boom state, deflection can be reduced by 20%-30% and the lifting capacity can be improved by above 200%.

-  **Slewing system**
- It consists of constant displacement motor and slewing reducer with mature technology. 360° full-rotation can be achieved through external gearing with slewing ring. With slewing speed of 0-1.3rpm and with infinitely variable speed adjustment. Slewing hydraulic system adopts the closed system, which not only avoids throttling loss of the open system but also ensures a high efficiency. Emergency brake can be achieved through electric proportional brake pedal.

-  **Counterweight**
- Combined variable counterweights are used with 0t, 14t, 28.5t, 43t, 56t, 80t, 100t seven combinations to meet requirements of different operating conditions and maximize structural parts performance. It can be self-assembled and disassembled through remote control with good micro-mobility.

Superstructure

Safety system

- Load moment limiter: With analytical mechanics method, the load moment limiter calculation system is established based on the load mechanical model. The rated hoisting accuracy can be up to $\pm 3\%$ through on-line non-load calibration.
- Hydraulic system is configured with the balance valve overflow valve, and two-way hydraulic lock etc. ensuring stable and reliable operation of the hydraulic system.
- Main and auxiliary winches are configured with 3-wraps protectors to prevent over roll-out of wire rope.
- Boom and jib are configured with height limiters at ends to prevent over-hoist of the wire rope.
- Boom head is equipped with anemometer to detect whether the high-altitude wind speed is within the allowable range.
- With superlift rope rewinding and release pull protection program, jib installation protection and lifting load protection program.

Main hoisting system

- Planet-gear speed reducer and special groove winch drum are driven by hydraulic motor with brake installed internally.
- Wire rope lock: High-quality wire rope lock with casting at ends is applied. It is installed in the lock sleeve directly, which improves the replacement speed of the lifting rate.
- Spec. of wire rope: $\phi 24-2160$, non-rotating;
- Length: About 400m;
- Max. single rope speed (outer layer): About 130m/min.

Luffing jib winch mechanism

- Planet-gear speed reducer and special groove winch drum are driven by hydraulic motor, with brake installed internally. Anti-winding wire rope is used. Separate rotation can be achieved together with the auxiliary hoisting system.
- Spec. of wire rope: $\phi 24-2160$, non-rotating;
- Length: About 700m;
- Max. single rope speed (outer layer): about 130m/min.

Chassis

Cab

- Cab is made of new steel structure self-developed by SANY, featuring excellent shock absorption and tightness. It is configured with swing-out doors at both sides, pneumatically suspended driver's seat and passenger's seat, adjustable steering wheel, large rearview mirror, comfortable driver's chair with a headrest, anti-fog fan, air conditioner, stereo radio and complete control instruments and meters, providing more comfortable and safe operation experience.

Carrier frame

- Designed and manufactured by SANY, anti-torsion box structure is welded with fine-grain high-strength steel plate to provide strong load bearing capacity.

Outriggers

- Four-point supporting of the H-shaped outriggers ensures easy operation and strong stability with Max. span up to 8.95m \times 8.6m. Outrigger telescopic hydraulic system adopts the electro proportional control technology with wireless remote control configured. Outrigger control panel can display all loads, with automatic level function to ensure high control precision and simple operation.

Engine

- Type: Electric controlled, V-type eight-cylinder, water cooled, supercharged and inter-cooling diesel engine
- Rated power: 440kw/1800r/min
- Max torque: 2800Nm/1300rpm
- Environment-protection: Emission complies with EuroIV standard
- Capacity of fuel tank:550L.

Transmission system

- Gearbox: Manual / Automatic gearbox is adopted with 12-gear and large speed ratio range applied, which meets the requirements of low gradeability speed and high speed traveling.
- Transfer case: Transfer case with a large input torque is used with rated torque up to 30000N.m and with differential lock cylinder configured.
- Transmission shaft: with optimized arrangement of the transmission shaft, the transmission is more stable and reliable. For most optimized transmission, face-tooth coupling transmission shaft is used with large transmission torque up to 30000Nm.

Axles

- Full-axle steering is applied with axles 1, 3, 5 and 6 used for drive operation and with axles 1, 3, 5 and 6 equipped with differential locks for planetary transmission. Axles 1 and 2 adopt the bar-feedback hydraulic power steering systems and axles 3, 4, 5 and 6 adopt the electro-hydraulic control steering system. With assist in speed control and special steering mode optional applied, thus ensuring easy steering and flexible operation.

Suspension system

- Axle suspension devices adopt the height-adjustable oil-gas suspension devices equipped with the hydraulic lock, with stroke of suspension cylinder of +160/-130mm to achieve suspension, rigid locking, automatic leveling, overall lifting and lowering, single-point lifting and lowering modes. Load applied on each axle is no more than 12t. With good trafficability and adaptability of a variety of severe operating conditions and road conditions, smooth and comfortable travelling and side stability of the vehicle are guaranteed.

Tyres

- 12 * 16.00R25

Chassis

Steering system

- Servo power steering gear and dual-circuit system hydraulic steering device are used with emergency steering pump equipped. Steering can be adjusted through regulating the speed. Axles 3 and 4 steering will stop from 30km/h and from 60km/h for axles 5 and 6.
- Six types steering modes: 1) Road running mode (default mode); 2) Full-wheel steering mode. 3) Crab-type mode. 4) Steering mode without deflection. 5) Independent rear-axle steering mode. 6) Steering mode with rear axle locked.

Brakes system

- Brakes system includes traveling brake, parking brake, emergency brake, and auxiliary brake.
- Traveling brake: All wheels use the air servo brakes and dual-circuit brake system and are equipped with drum brakes.
- Parking brake: Force driven by accumulator is applied on the second to sixth axle. Emergency brake: Accumulator is used not only for cutting-off brake but also for emergency brake;
- Auxiliary brake consists of engine brake and exhaust brake etc. There are double brakes for the engine, hydraulic power retarder brake for reducer and eddy current retarder brake for four axle which ensure high safety and reliability of the travelling.

Electrical system

- With 24V DC power supply, cutting off power of the undercarriage can be achieved; automotive lighting system is equipped; vehicle actions, such as throttle and outrigger control, can be electrically controlled; electrical system has strong detection, logic, and calculation capacity with fault self-diagnosis, centralized display and self-protection function;
- Chassis adopts CAN-bus system; multifunctional centralized display system is used; power consumption is small with maximum value of only 5w; four functional keys are provided on the user interface; LCD display is used with adjustable contrast ratio.

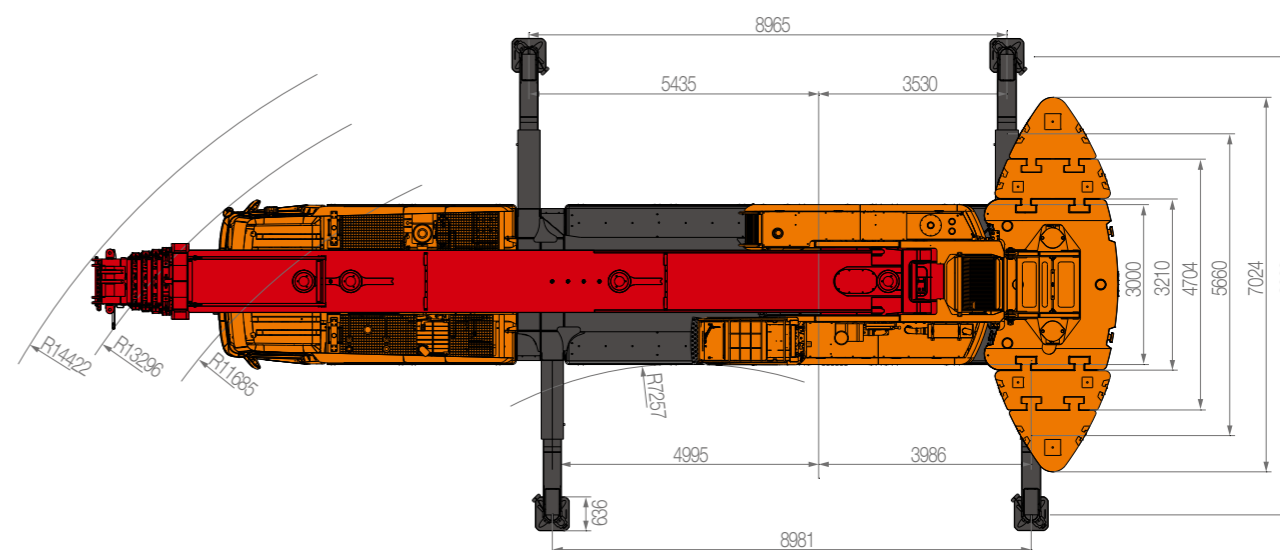
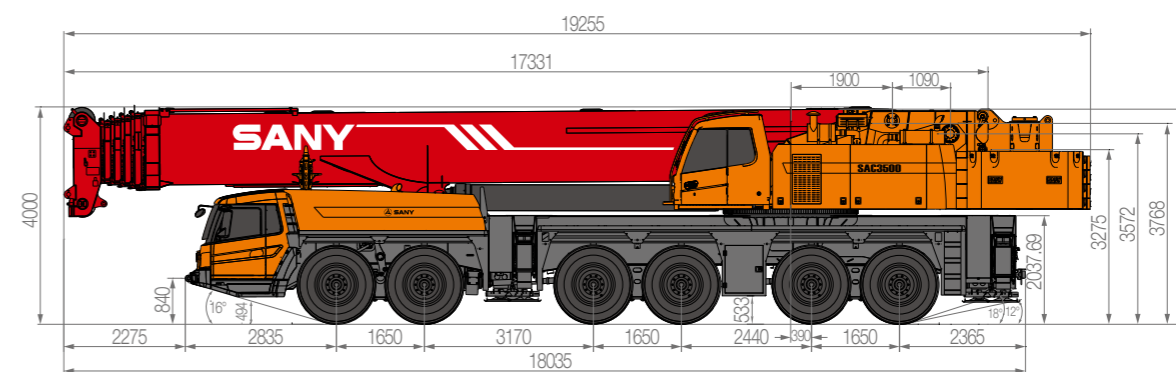

Type	Item	Parameter	
Capacity	Max. lifting capacity	350t	
Dimensions	Overall length	18035mm	
	Overall width	3000mm	
	Overall height	4000mm	
	Axle distance	Axle-1,2	1650mm
		Axle-2,3	3170mm
		Axle-3,4	1650mm
Axle-4,5		2440mm	
Axle-5,6		1650mm	
Weight	Overall weight	72000 kg	
	Axle load	Axle load-1,2,3	12000 kg
		Axle load-4,5,6	12000 kg
	Rated power	440 kW/1800rpm	
	Rated torque	2800 N.m/ 1300 rpm	
Traveling	Rated power	205 kW/2200rpm	
	Rated torque	1100 N.m/ 1200 rpm~1600 rpm	
Traveling	Max.traveling speed	80 km/h	
	Turning radius	Min.turning radius	12 m
		Min.turning radius of boom head	14.4 m
	Wheel formula	12 × 8	
	Min.ground clearance	360 mm	
	Approach angle	16 °	
	Departure angle	18 °	
	Max.gradeability	49%	
	Fuel consumption per 100km	≤ 114 L	
Main Performance Data	Temperature range	- 20 °C ~ + 50 °C	
	Min.rated range	3 m	
	Tail slewing radius of swingtable	5735 mm	
	Boom section	6	
	Boom shape	U-shaped	
	Max.lifting moment	Base boom	11520 kN·m
		Full-extend boom	8180 kN·m
		Max. length of main boom+fixed jib	1995 kN·m
		Max. length of main boom+ tower jib	1768 kN·m
	Boom length	Base boom	15.2 m
		Full-extend boom	70 m
		Max. length of main boom+fixed jib	65.6+2.5+42 m
		Max. length of main boom+tower jib	55.5+7+78 m
Outrigger span (Longitudinal×Transversal)	8.95 × 8.6 m		
Jib offset	0°,20°,40°		
Working speed	Max.single rope lifting speed of main winch (no load)	130 m/min	
	Max.single rope lifting speed of auxiliary winch (no load)	130 m/min	
	Full extension/retraction time of boom	540 / 540 s	
	Full lifting/descending time of boom	75 / 110 s	
	Slewing speed	1.2 r/min	
Aircondition	Aircondition in up cab	Cooling/Heating	
	Aircondition in low cab	Cooling/Heating	



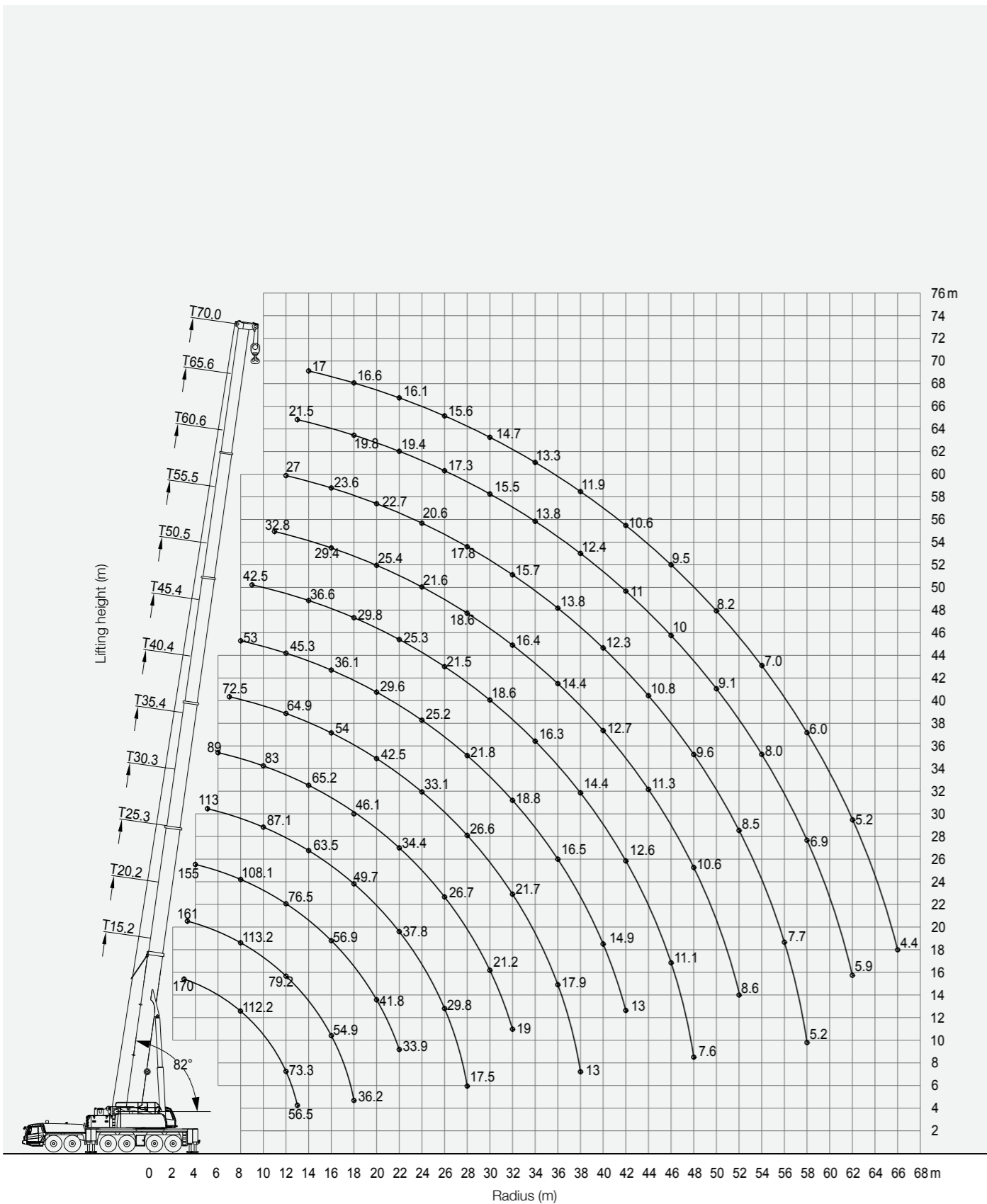

Prerequisites:

- ① Boom operating conditions (fully extended boom length), max. length is 70m
- ② The span of outriggers is 8.95m x 8.6m
- ③ 360° rotation is applied
- ④ Counterweight is 100T

working range	Main boom												working range	
	15.2m*	15.2m	20.2m	25.3m	30.3m	35.4m	40.4m	45.4m	50.5m	55.5m	60.6m	65.6m		70m
3	350.0	170.0												3
3.5	260.0	170.0	161.0											3.5
4	235.0	170.0	161.0	155.0										4
4.5	215.0	165.2	161.0	147.9										4.5
5	198.0	155.0	156.0	145.2	113.0									5
6	175.0	137.8	138.9	130.1	112.0	89.0								6
7	157.0	123.8	125.0	120.5	106.2	87.0	72.5							7
8	142.0	112.2	113.2	108.1	103.2	86.0	70.5	53.0						8
9	128.0	102.5	103.0	98.1	96.0	85.0	69.5	52.1	42.5					9
10	112.0	94.2	94.2	90.0	87.1	83.0	68.5	50.8	41.5					10
11	98.0	84.7	86.5	83.0	79.5	81.0	66.5	48.3	40.3	32.8				11
12	86.0	73.3	79.2	76.5	72.9	76.0	64.9	45.3	38.5	32.4	27.0			12
13	66.0	56.5	72.7	71.6	68.0	70.8	62.5	43.2	38.2	31.3	26.5	21.5		13
14			67.1	67.1	63.5	65.2	60.0	40.5	36.6	30.2	26.0	21.4	17.0	14
16			54.9	56.9	57.0	54.6	54.0	36.1	32.9	29.4	23.6	20.8	16.8	16
18			36.2	48.4	49.7	46.1	49.1	32.7	29.8	27.7	23.5	19.8	16.6	18
20				41.8	43.1	39.6	42.5	29.6	27.4	25.4	22.7	19.5	16.3	20
22				33.9	37.8	34.4	37.3	27.3	25.3	23.4	22.0	19.4	16.1	22
24					33.2	30.2	33.1	25.2	23.3	21.6	20.6	18.2	15.8	24
26					29.8	26.7	29.5	23.2	21.5	20.2	19.0	17.3	15.6	26
28					17.5	23.7	26.6	21.8	19.8	18.6	17.8	16.2	15.4	28
30						21.2	24.0	20.1	18.6	17.5	16.7	15.5	14.7	30
32						19.0	21.7	18.8	17.4	16.4	15.7	14.8	14.0	32
34							19.7	17.6	16.3	15.4	14.7	13.8	13.3	34
36							17.9	16.5	15.3	14.4	13.8	13.2	12.5	36
38							13.0	15.6	14.4	13.5	12.9	12.4	11.9	38
40								14.9	13.5	12.7	12.3	11.8	11.4	40
42								13.0	12.6	11.9	11.5	11.0	10.6	42
44									12.0	11.3	10.8	10.5	10.1	44
46									11.1	10.6	10.3	10.0	9.5	46
48									7.6	10.1	9.6	9.4	8.8	48
50										9.5	8.8	9.1	8.2	50
52										8.6	8.5	8.5	7.6	52
54											7.9	8.0	7.0	54
56											7.7	7.4	6.5	56
58											5.2	6.9	6.0	58
60												6.3	5.6	60
62												5.9	5.2	62
64													4.8	64
66													4.4	66
68														68
n		14	13	13	10	8	6	5	4	3	3	2	2	n
m/s	9.0	9.0	9.0	9.0	9.0	9.0	9.0	9.0	9.0	9.0	9.0	9.0	9.0	m/s

illustration: *With additional lifting equipments, Over rear;

- 1. Values listed in the table refer to rated lifting capacity measured at flat and solid ground under the lever state of the crane;
- 2. Values listed in the table refer to rated boom length, the max values of different telescopic conditions.
- 3. Rated lifting capacity listed in the table included weights of lifting hooks and hangers;
- 4. If actual boom length and range are between two values specified in the table, larger value will determine the lifting capacity.

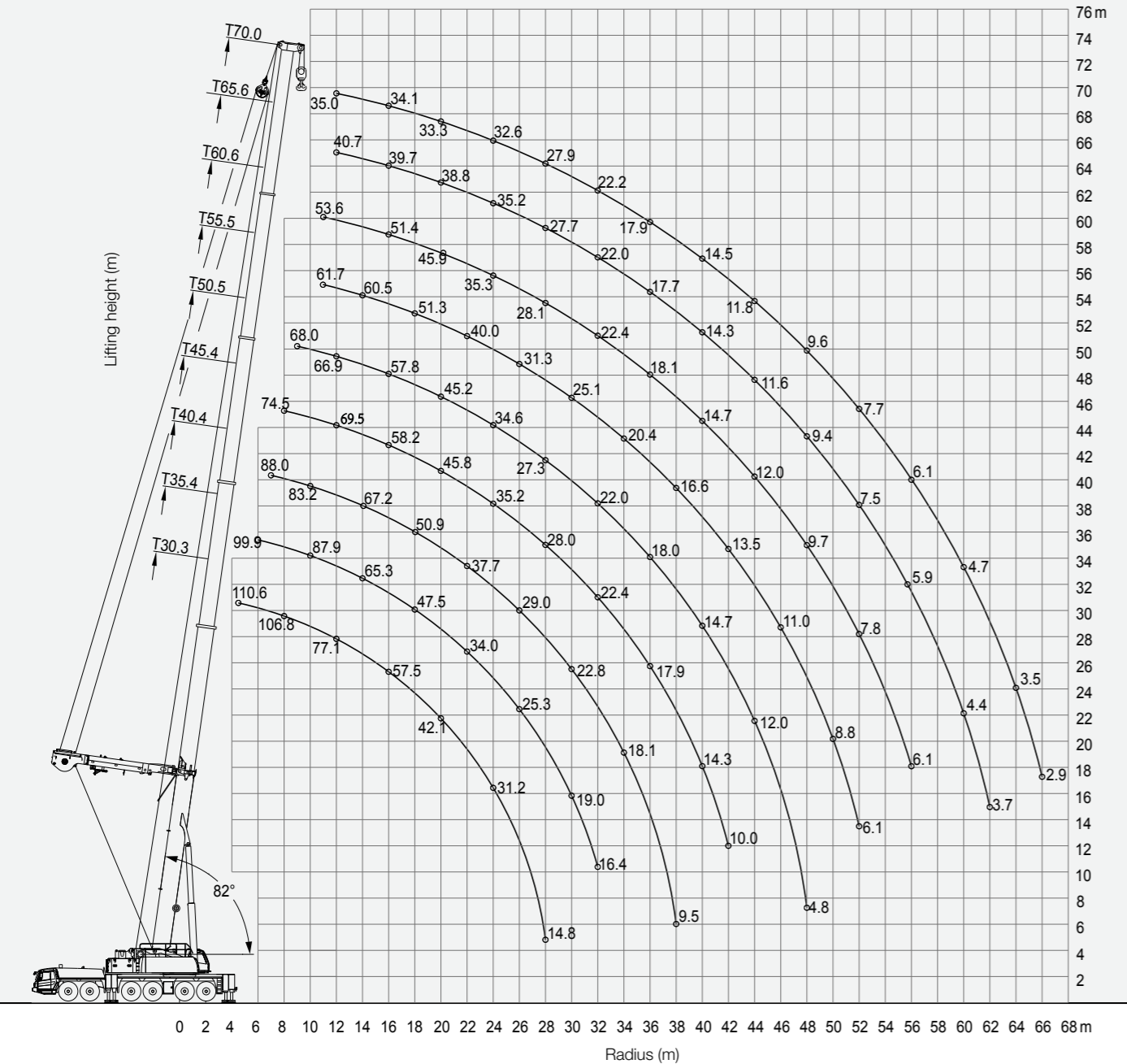
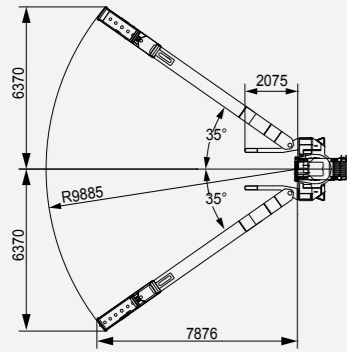

Prerequisites:

- ① Boom operating conditions (fully extended boom length), max. length is 70m
- ② The span of outriggers is 8.95m×8.6m
- ③ 360° rotation is applied
- ④ Counterweight is 100T
- ⑤ Superlift angle of one-side unfold is 35°

working range	Main boom + Superlift									working range
	30.3m	35.4m	40.4m	45.4m	50.5m	55.5m	60.6m	65.6m	70m	
4.5	110.6									4.5
5	112.7									5
6	112.7	99.9								6
7	111.3	102.4	88.0							7
8	106.8	101.2	87.0	74.5						8
9	98.7	94.9	86.0	74.5	68.0					9
10	87.7	87.9	83.2	74.1	68.1					10
11	83.5	80.6	79.1	72.3	68.1	61.7	53.6			11
12	77.1	77.0	74.9	69.5	66.9	61.3	53.3	40.7	35.0	12
13	71.4	71.3	70.4	67.1	64.6	61.1	52.9	40.5	34.8	13
14	66.4	65.3	67.2	65.1	62.3	60.5	52.2	40.2	34.4	14
16	57.5	55.4	58.6	58.2	57.8	56.5	51.4	39.7	34.1	16
18	49.5	47.1	50.9	51.7	51.4	51.3	49.7	39.3	33.7	18
20	42.1	39.8	43.6	45.8	45.2	45.8	45.9	38.8	33.3	20
22	36.2	34.0	37.7	40.0	39.3	40.0	40.1	38.3	33.0	22
24	31.4	29.3	33.0	35.2	34.6	35.2	35.3	35.2	32.6	24
26	25.6	25.3	29.0	31.3	30.7	31.3	31.4	31.2	31.5	26
28	14.8	21.9	25.7	28.0	27.3	28.0	28.1	27.7	27.9	28
30		19.0	22.8	25.0	24.5	25.1	25.0	24.6	24.8	30
32		16.4	20.3	22.4	22.0	22.7	22.4	22.0	22.2	32
34			18.1	20.0	19.9	20.4	20.1	19.7	19.9	34
36			16.1	17.9	18.0	18.4	18.1	17.7	17.9	36
38			9.5	16.1	16.3	16.6	16.3	15.9	16.1	38
40				14.3	14.7	14.9	14.7	14.3	14.5	40
42				10.0	13.4	13.5	13.3	12.9	13.1	42
44					12.0	12.2	12.0	11.6	11.8	44
46					9.7	11.0	10.8	10.5	10.7	46
48					4.8	9.9	9.7	9.4	9.6	48
50						8.8	8.7	8.4	8.6	50
52						6.1	7.8	7.5	7.7	52
54							6.9	6.7	6.9	54
56							6.1	5.9	6.1	56
58								5.1	5.4	58
60								4.4	4.7	60
62								3.7	4.1	62
64									3.5	64
66									2.9	66
68										68
n	10.0	9.0	7.0	6.0	5.0	5.0	5.0	4.0	3.0	n
m/s	9.0	9.0	9.0	9.0	9.0	9.0	9.0	9.0	9.0	m/s

- 1. Values listed in the table refer to rated lifting capacity measured at flat and solid ground under the lever state of the crane;
- 2. Values listed in the table refer to rated boom length, the max values of different telescopic conditions.
- 3. Rated lifting capacity listed in the table included weights of lifting hooks and hangers;
- 4. If actual boom length and range are between two values specified in the table, larger value will determine the lifting capacity.

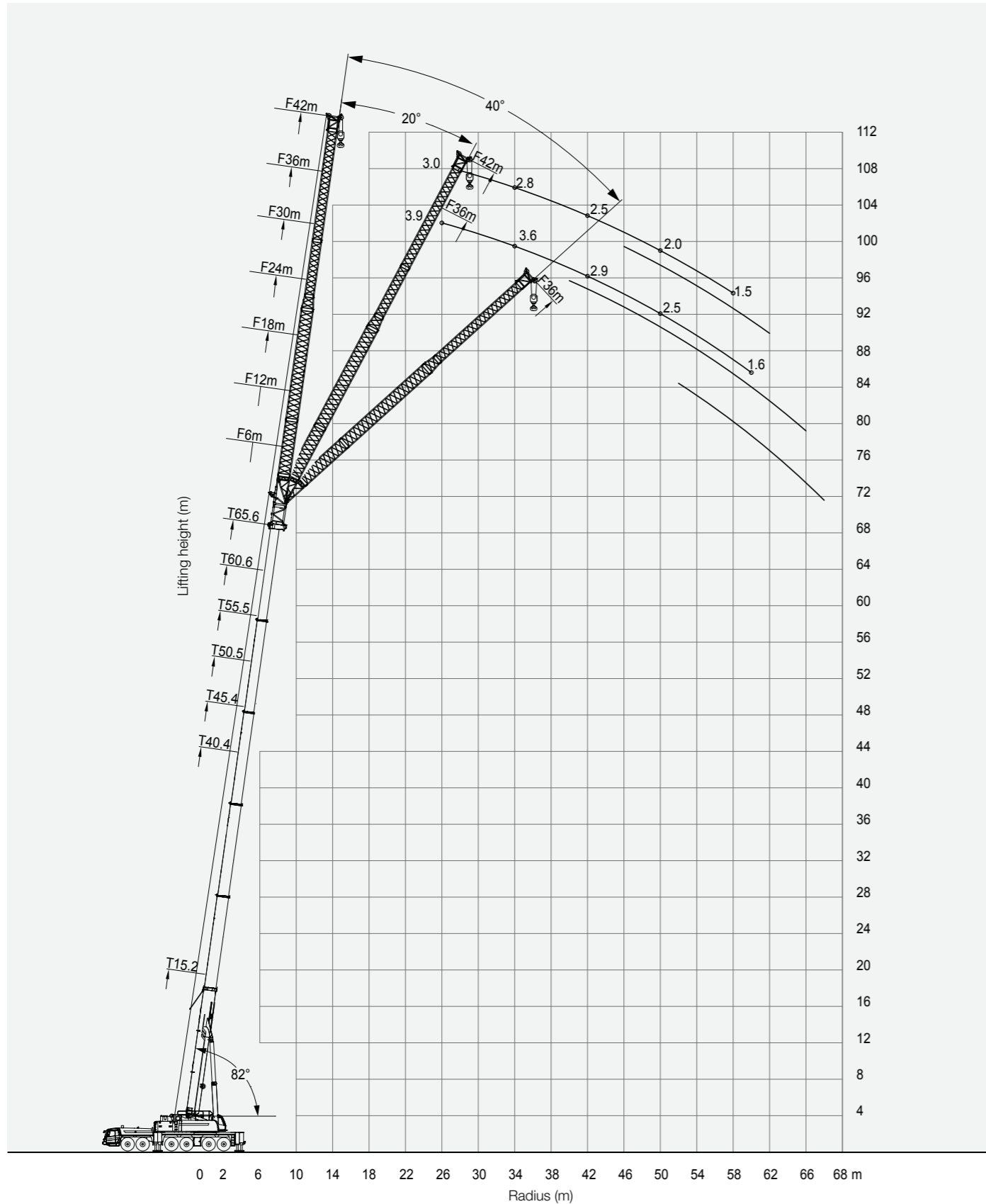

- Prerequisites:**
- ① Boom operating conditions(boom length + adapter+ jib length), max.length is 65.6m+2.5m+6m
 - ② The span of outriggers is 8.95m×8.6m
 - ③ 360°rotation is applied
 - ④ Counterweight is 100T

working range	Main boom +Adapter+ Jib																		working range			
	15.2+2.5m*			40.4+2.5m*			45.4+2.5m*			50.5+2.5m*			55.5+2.5m*			60.6+2.5m*				65.6+2.5m*		
	0°	20°	40°	0°	20°	40°	0°	20°	40°	0°	20°	40°	0°	20°	40°	0°	20°	40°	0°	20°	40°	
3.5																						3.5
4.0	43.2																					4.0
4.5	41.6																					4.5
5	39.8																					5
6	36.4																					6
7	33.0	30.0																				7
8	30.2	27.6	25.6																			8
9	27.6	25.8	24.1																			9
10	26.3	24.3	22.7																			10
11	24.6	22.8	21.6																			11
12	23.1	21.6	20.3																			12
13	21.2	20.7	19.6																			13
14	19.9	19.5	18.6																			14
16	18.3	17.5	16.5														17.3					16
18	16.6	16.3	14.3													16.4	16.3		13.8			18
20	15.3	15.1	8.7													15.3	15.3	15.4	13.1	13.0		20
22																14.2	14.4	14.5	12.4	12.4	10.3	22
24																13.3	13.5	13.7	11.7	11.7	10.2	24
26																12.4	12.6	12.8	11.0	11.1	10.0	26
28																11.5	11.7	11.9	10.3	10.4	9.8	28
30																10.7	10.9	11.1	9.6	9.8	9.7	30
32																10.0	10.2	10.4	9.0	9.2	9.4	32
34																9.3	9.5	9.7	8.4	8.6	8.8	34
36																8.7	8.9	9.0	7.8	8.0	8.2	36
38																8.0	8.2	8.3	7.3	7.5	7.7	38
40																7.4	7.6	7.7	6.8	7.0	7.1	40
42																6.9	7.1	7.0	6.3	6.5	6.6	42
44																6.3	6.5	6.5	5.8	6.1	6.1	44
46																5.8	6.0		5.4	5.6	5.7	46
48																5.3	5.5		5.0	5.2	5.0	48
50																4.9	5.0		4.6	4.8		50
52																4.4	4.6		4.2	4.4		52
54																4.0	4.2		3.8	4.0		54
56																3.7	3.8		3.4	3.6		56
58																3.3	3.4		3.1	3.3		58
60																3.0			2.8	3.0		60
62																2.7			2.6	2.7		62
64																2.5			2.3			64
66																1.8			2.0			66
68																			1.8			68
70																				1.6		70

*adapter

- Prerequisites:**
- ① Boom operating conditions(boom length + adapter + jib length), max.length is 65.6m+2.5m+24m
 - ② The span of outriggers is 8.95m×8.6m
 - ③ 360°rotation is applied
 - ④ Counterweight is 100T

working range	Main boom + Adapter+ Jib																								working range
	15.2+2.5m*			40.4+2.5m*			45.4+2.5m*			50.5+2.5m*			55.5+2.5m*			60.6+2.5m*			65.6+2.5m*						
	0°	20°	40°	0°	20°	40°	0°	20°	40°	0°	20°	40°	0°	20°	40°	0°	20°	40°	0°	20°	40°				
8	16.3																						8		
9	15.6																						9		
10	14.5																						10		
11	13.6																						11		
12	112.8																						12		
13	11.7																						13		
14	10.8			13.5																			14		
16	9.6	9.6		12.8			13.1																16		
18	8.4	8.5		12.1			12.5			12.5													18		
20	7.6	7.9		11.6			12.0			11.9			11.0			9.1							20		
22	7.0	7.1	6.6	11.1	7.7		11.5			11.3			10.7			8.9			7.0				22		
24	6.3	6.4	6.2	10.4	7.3		10.8	7.5		10.6			10.1			8.4			6.7				24		
26	5.8	5.9	5.6	9.7	6.7		10.0	6.9		9.7	7.1		9.3			7.8			6.3				26		
28	5.4	5.5	5.3	8.8	6.1	4.3	8.9	6.2		8.8	6.4		8.5	7.2		7.1			5.7				28		
30	5.0	5.0	5.0	7.8	5.5	4.2	8.0	5.6	4.3	7.9	5.8		7.7	6.7		6.4	6.7		5.2				30		
32	4.6	4.5	4.7	7.4	5.2	4.2	7.6	5.5	4.2	7.5	5.6	4.2	7.2	6.2		6.0	6.3		5.0	5.2			32		
34	4.2	4.3	4.5	6.9	5.1	4.0	7.1	5.2	4.1	7.1	5.4	4.2	6.8	5.6	4.2	5.8	5.8		4.8	4.8			34		
36	3.9	4.0	4.3	6.5	4.9	3.9	6.7	5.1	4.0	6.8	5.2	4.1	6.4	5.4	4.2	5.4	5.2	4.2	4.6	4.4			36		
38	3.6	3.8		6.2	4.6	3.8	6.4	4.9	3.9	6.5	5.1	4.0	6.0	5.2	4.1	5.1	5.1	4.1	4.3	4.0	3.7		38		
40				5.9	4.5	3.7	6.0	4.7	3.8	6.1	4.9	3.9	5.6	5.1	4.0	4.8	4.8	4.1	4.1	3.8	3.6		40		
42				5.5	4.4	3.7	5.8	4.6	3.7	5.9	4.7	3.8	5.3	4.9	3.9	4.5	4.7	4.0	3.9	3.7	3.4		42		
44				5.3	4.2	3.7	5.5	4.4	3.7	5.6	4.6	3.7	4.9	4.7	3.8	4.3	4.5	3.9	3.7	3.5	3.3		44		
46				5.0	4.2	3.6	5.3	4.3	3.7	5.3	4.5	3.7	4.6	4.6	3.7	3.9	4.3	3.8	3.4	3.4	3.2		46		
48				4.8	4.0	3.6	5.0	4.2	3.6	4.9	4.3	3.7	4.3	4.4	3.7	3.7	4.0	3.8	3.2	3.2	3.1		48		
50				4.6	3.9	3.5	4.8	4.1	3.6	4.6	4.2	3.6	4.0	4.2	3.7	3.4	3.7	3.7	3.0	3.1	3.0		50		
52				4.3	3.8		4.6	4.0	3.5	4.3	4.2	3.6	3.7	3.9	3.7	3.1	3.5	3.7	2.7	3.0	2.9		52		
54				4.2	3.7		4.4	3.9		3.9	4.0	3.5	3.4	3.7	3.6	2.9	3.2	3.4	2.6	2.8	2.8		54		
56				4.0	3.7		4.3	3.8		3.7	3.9	3.5	3.1	3.4	3.6	2.6	3.0	3.1	2.3	2.6	2.7		56		
58				3.8	3.6		4.0	3.7		3.3	3.7	3.3	2.9	3.1	3.3	2.5	2.7	2.9	2.1	2.4	2.6		58		
60				3.7			3.7	3.7		3.1	3.4		2.6	2.9		2.2	2.6	2.6	2.0	2.2	2.5		60		
62				3.7			3.5	3.6		2.8	3.1		2.4	2.6		2.0	2.3	2.5	1.7	2.0	2.2		62		
64				3.1			3.2			2.6	2.8		2.1	2.4		1.8	2.0		1.5	1.8	2.0		64		
66							3.0			2.4	2.6		2.0	2.1		1.5	1.9			1.6	1.8		66		
68							2.6			2.1	2.4		1.7	2.0			1.6						68		
70										2.0			1.5	1.7									70		
72										1.8													72		
74																							74		
76																							76		
78																							78		

*adapter

- Prerequisites:**
- ① Boom operating conditions(boom length + adapter + jib length), max.length is 65.6m+2.5m+30m
 - ② The span of outriggers is 8.95m×8.6m
 - ③ 360°rotation is applied
 - ④ Counterweight is 100T

working range	Main boom + Adapter + Jib																								working range	
	15.2+2.5m*			40.4+2.5m*			45.4+2.5m*			50.5+2.5m*			55.5+2.5m*			60.6+2.5m*			65.6+2.5m*							
	0°	20°	40°	0°	20°	40°	0°	20°	40°	0°	20°	40°	0°	20°	40°	0°	20°	40°	0°	20°	40°					
9	12.3																						9			
10	12.1																						10			
11	11.8																						11			
12	11.3																						12			
13	10.6																						13			
14	10.1																						14			
16	9.2						9.8						9.6										16			
18	8.5	7.0					9.2						9.0			8.8							18			
20	7.6	6.5					8.6						8.5			8.3			7.6				20			
22	7.0	6.0					8.2						8.0			8.0			7.3		6.8		22			
24	6.3	5.6					7.8						7.6			7.6			7.1		6.7	5.1	24			
26	5.6	5.1	4.5	7.3	5.8		7.2						7.2			6.7			6.5		6.5	5.0	26			
28	5.2	4.6	4.0	7.0	5.6		6.9	5.4					6.9			6.5			6.5		6.2	4.8	28			
30	4.7	4.3	3.8	6.7	5.5		6.6	5.3					6.5	5.2		6.2			6.0		6.0	4.7	30			
32	4.4	4.0	3.6	6.4	5.3		6.3	5.1					6.3	5.0		6.0	5.0		5.8		5.8	4.5	32			
34	4.0	3.6	3.4	6.1	5.1	4.0	6.0	5.0					6.0	4.8		5.7	4.8		5.5	4.5	4.3		34			
36	3.7	3.4	3.2	5.9	4.9	3.8	5.7	4.7	3.7	5.7	4.6	3.6	5.4	4.6		5.2	4.3		5.2	4.3	4.1	3.6	36			
38	3.5	3.2	3.0	5.6	4.7	3.7	5.4	4.5	3.6	5.4	4.4	3.5	5.2	4.4	3.5	4.9	4.1		4.9	4.1	3.9	3.4	38			
40	3.2	2.9	2.8	5.2	4.5	3.6	5.1	4.3	3.5	5.1	4.2	3.4	4.9	4.2	3.4	4.7	4.1		4.7	4.1	3.8	3.3	40			
42	2.9	2.6		5.0	4.3	3.5	4.8	4.1	3.4	4.8	4.0	3.3	4.8	4.1	3.3	4.5	3.9	3.2	4.5	3.9	3.2	3.6	3.1	42		
44	2.6			4.7	4.1	3.4	4.6	4.0	3.3	4.7	3.9	3.2	4.5	3.9	3.2	4.2	3.8	3.2	4.2	3.8	3.2	3.4	3.0	2.7	44	
46				4.4	3.9	3.3	4.3	3.8	3.3	4.4	3.7	3.2	4.3	3.8	3.2	3.9	3.6	3.2	3.9	3.6	3.2	3.3	2.9	2.6	46	
48				4.2	3.7	3.2	4.2	3.6	3.3	4.3	3.6	3.2	4.3	3.6	3.2	3.9	3.6	3.2	3.6	3.5	3.1	3.1	2.9	2.5	48	
50				4.0	3.5	3.2	3.9	3.5	3.2	4.0	3.4	3.1	3.7	3.5	3.1	3.7	3.5	3.1	3.3	3.3	3.0	2.8	2.8	2.5	50	
52				3.8	3.4	3.1	3.7	3.3	3.1	3.8	3.3	3.1	3.8	3.3	3.1	3.4	3.3	3.0	3.1	3.2	3.0	2.6	2.7	2.4	52	
54				3.6	3.3	3.0	3.6	3.2	3.1	3.7	3.2	3.1	3.7	3.2	3.0	3.1	3.2	3.0	2.9	3.1	2.9	2.4	2.6	2.3	54	
56				3.4	3.1	3.0	3.4	3.2	3.0	3.5	3.1	2.9	3.5	3.1	2.9	3.2	2.9	2.9	3.2	2.9	2.6	2.9	2.2	2.5	2.3	56
58				3.2	3.0		3.2	3.1	3.0	3.2	3.0	2.9	3.2	3.0	2.9	2.6	3.0	2.9	2.4	2.7	2.8	2.0	2.4	2.3	58	
60				3.2	3.0		3.1	3.0		3.0	2.9	2.8	2.5	2.9	2.8	2.1	2.5	2.7	1.8	2.2	2.2				60	
62				3.0	2.9		3.0	2.9		2.7	2.8	2.8	2.2	2.7	2.8	2.0	2.3	2.5	1.7	2.0	2.1				62	
64				2.9	2.9		2.9	2.8		2.6	2.7		2.0	2.4	2.6	1.8	2.1	2.3		1.7	2.0				64	
66				2.8			2.8	2.7		2.3	2.7		1.8	2.3		1.5	1.9	2.1		1.7	1.8				66	
68				2.7			2.6	2.7		2.1</																

- Prerequisites:**
- ① Boom operating conditions(boom length + adapter+ jib length), max.length is 65.6m+2.5m+36m
 - ② The span of outriggers is 8.95m×8.6m
 - ③ 360°rotation is applied
 - ④ Counterweight is 100T

working range	Main boom + Adapter+ Jib																								working range
	15.2+2.5m*			40.4+2.5m*			45.4+2.5m*			50.5+2.5m*			55.5+2.5m*			60.6+2.5m*			65.6+2.5m*						
	0°	20°	40°	0°	20°	40°	0°	20°	40°	0°	20°	40°	0°	20°	40°	0°	20°	40°	0°	20°	40°				
10	10.0																							10	
11	9.6																							11	
12	9.2																							12	
13	9.0																							13	
14	8.4																							14	
16	8.0				8.1																			16	
18	7.2				7.6			7.5																18	
20	6.6				7.2			7.1			6.9													20	
22	6.0	5.3			6.8			6.8			6.5			6.2										22	
24	5.4	4.9			6.5			6.5			6.3			6.0			5.5							24	
26	5.0	4.5			6.2			6.2			6.0			5.8			5.3			3.9				26	
28	4.5	4.1			5.9			5.9			5.7			5.6			5.2			3.8				28	
30	4.1	3.8			5.7	4.6		5.6			5.5			5.3			5.0			3.7				30	
32	3.6	3.4	3.0		5.4	4.4		5.4	4.3		5.2			5.1			4.8			3.7				32	
34	3.6	3.0	2.7		5.2	4.1		5.1	4.0		5.0	3.8		4.9			4.8			3.6				34	
36	3.1	2.8	2.6		5.0	3.9		4.9	3.8		4.8	3.6		4.7	3.5		4.6			3.4				36	
38	2.8	2.6	2.5		4.7	3.7	2.8	4.6	3.6		4.5	3.4		4.4	3.3		4.4	3.2		3.2				38	
40	2.6	2.4	2.3		4.3	3.5	2.7	4.4	3.4	2.6	4.3	3.3		4.2	3.2		4.2	3.1		3.1	2.8			40	
42	2.4	2.2	2.1		4.1	3.3	2.6	4.1	3.3	2.5	4.0	3.2	2.4	4.0	3.1		3.9	3.0		2.9	2.7			42	
44	2.2	2.1	2.0		3.9	3.2	2.5	3.8	3.1	2.4	3.7	2.9	2.3	3.9	2.8	2.3	3.7	2.7		2.9	2.6			44	
46	2.0	1.9	1.9		3.6	3.0	2.5	3.7	3.0	2.4	3.6	2.8	2.3	3.6	2.7	2.2	3.5	2.7	2.2	2.8	2.6			46	
48	1.9				3.4	2.9	2.4	3.5	2.9	2.3	3.4	2.7	2.3	3.4	2.7	2.2	3.2	2.6	2.1	2.6	2.5			48	
50					3.2	2.9	2.3	3.2	2.8	2.2	3.2	2.7	2.2	3.3	2.6	2.1	3.0	2.5	2.0	2.5	2.4			50	
52					3.1	2.8	2.3	3.1	2.7	2.2	3.1	2.6	2.2	3.1	2.5	2.1	2.8	2.4	2.0	2.3	2.3	1.9		52	
54					2.9	2.6	2.2	3.0	2.6	2.1	3.0	2.5	2.2	2.9	2.4	2.0	2.6	2.3	2.0	2.1	2.2	1.9		54	
56					2.8	2.5	2.2	2.8	2.5	2.1	2.8	2.4	2.1	2.7	2.3	2.0	2.4	2.3	2.0	1.9	2.1	1.8		56	
58					2.6	2.4	2.2	2.7	2.4	2.1	2.7	2.3	2.1	2.6	2.3	2.0	2.2	2.2	2.0	1.8	2.1	1.8		58	
60					2.5	2.4	2.1	2.6	2.3	2.0	2.6	2.2	2.1	2.3	2.2	1.9	1.9	2.1	1.9	1.6	2.0	1.7		60	
62					2.4	2.3	2.1	2.4	2.3	2.0	2.5	2.1	2.0	2.2	2.1	1.9	1.7	2.0	1.9		1.9	1.7		62	
64					2.3	2.2		2.3	2.2	2.0	2.3	2.1	2.0	1.9	2.1	1.9	1.5	1.8	1.9		1.7	1.6		64	
66					2.3	2.1		2.3	2.1		2.1	2.1	2.0	1.7	2.0	1.9		1.6	1.8		1.6	1.6		66	
68					2.2	2.1		2.2	2.1		2.0	2.0	2.0	1.5	1.8	1.9		1.5	1.7			1.5		68	
70					2.1	2.0		2.1	2.0		1.8	1.9			1.6	1.8								70	
72					2.0			2.0	2.0		1.7	1.9				1.5								72	
74					1.9			1.9	1.9		1.5	1.7												74	
76																								76	
78																								78	

*adapter

- Prerequisites:**
- ① Boom operating conditions(boom length + adapter+ jib length), max.length is 65.6m+2.5m+42m
 - ② The span of outriggers is 8.95m×8.6m
 - ③ 360°rotation is applied
 - ④ Counterweight is 100T

working range	Main boom + Adapter+ Jib																								working range
	15.2+2.5m*			40.4+2.5m*			45.4+2.5m*			50.5+2.5m*			55.5+2.5m*			60.6+2.5m*			65.6+2.5m*						
	0°	20°	40°	0°	20°	40°	0°	20°	40°	0°	20°	40°	0°	20°	40°	0°	20°	40°	0°	20°	40°				
11	8.0																							11	
12	7.6																							12	
13	7.2																							13	
14	7.0																							14	
16	6.6																							16	
18	6.1																							18	
20	5.6																							20	
22	5.3																							22	
24	4.8																							24	
26	4.4	3.6																						26	
28	4.0	3.3																						28	
30	3.7	3.1																						30	
32	3.4	2.8																						32	
34	3.1	2.7																						34	
36	2.9	2.5	1.9																					36	
38	2.6	2.3	1.8																					38	
40	2.5	2.2	1.7																					40	
42	2.3	2.0	1.6																					42	
44	2.1	1.9	1.5																					44	
46	2.0	1.7	1.4																					46	
48	1.9	1.6	1.3																					48	
50	1.8	1.4	1.3																					50	
52	1.6	1.3	1.2																					52	
54	1.5	1.2																						54	
56	1.3																							56	
58																								58	
60																								60	
62																								62	
64																								64	
66																								66	
68																								68	
70																								70	
72																								72	
74																								74	
76																								76	
78																								78	
80																								80	
82																								82	
84																								84	

*adapter

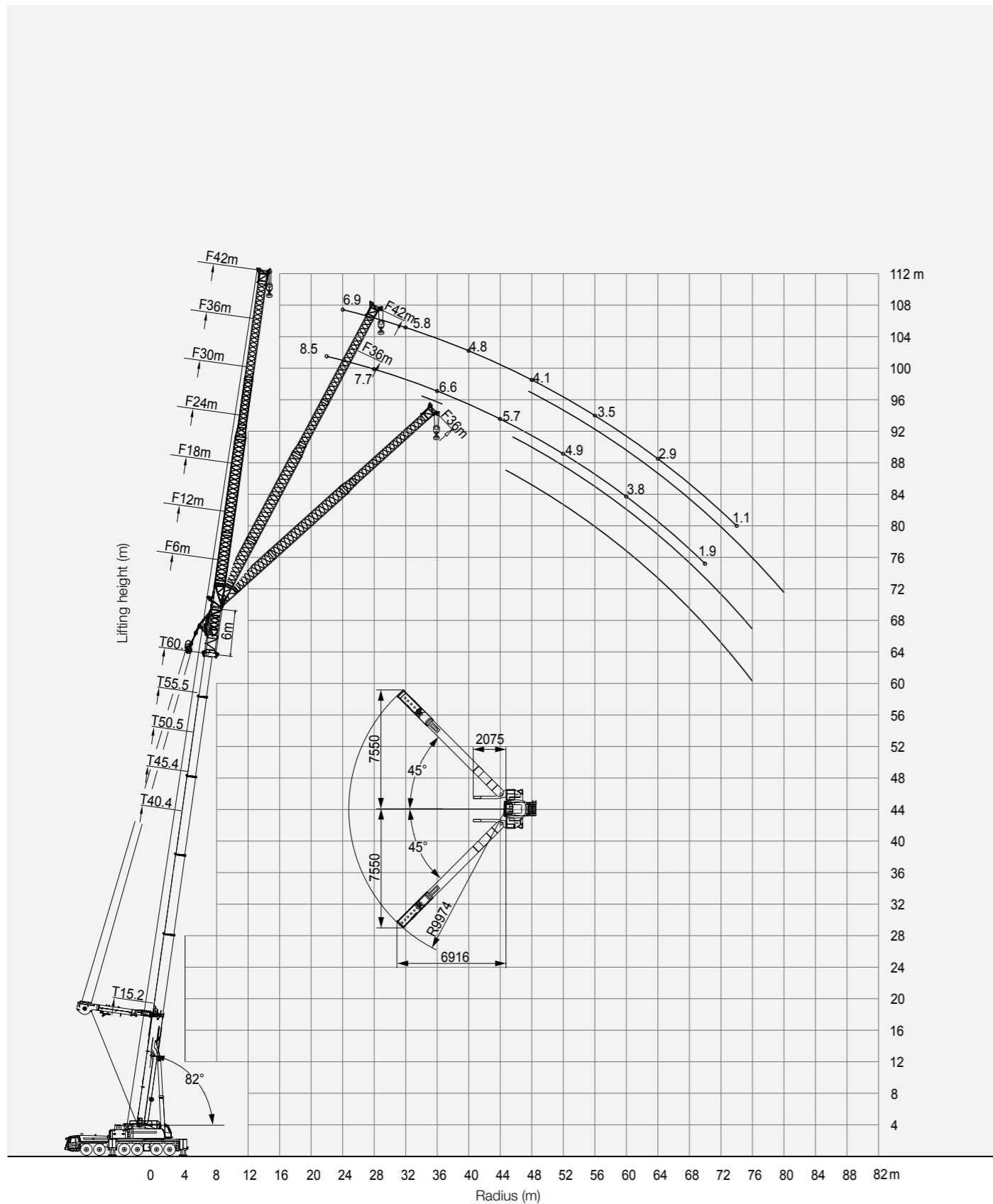

- Prerequisites:**
- ① Boom operating conditions(boom length + adapter+ jib length), max.length is 65.6m+6m+6m
 - ② The span of outriggers is 8.95m×8.6m
 - ③ 360°rotation is applied
 - ④ Counterweight is 100T
 - ⑤ Superlift angle of one-side unfold is 45°

working range	Main boom+ Adapter+ Jib+ Superlift															working range				
	40.4+6m*			45.4+6m*			50.5+6m*			55.5+6m*			60.6+6m*				65.6+6m*			
	0°	20°	40°	0°	20°	40°	0°	20°	40°	0°	20°	40°	0°	20°	40°		0°	20°	40°	
10																				10
11																				11
12																				12
13																				13
14																				14
16													31.9							16
18													31.2	31.4		27.8				18
20													30.0	30.2		27.2	27.4			20
22													28.8	29.1		26.3	26.5			22
24													27.6	27.8		25.3	25.5			24
26													25.7	25.9		24.3	24.5			26
28													24.0	24.1		22.9	23.2			28
30													21.1	22.6		20.3	21.7			30
32													18.6	20.5		18.0	19.8			32
34													16.5	18.1		15.9	17.6			34
36													14.6	16.1		14.2	15.7			36
38													12.9	14.3		12.6	14.0			38
40													11.4	12.6		11.2	12.4			40
42													10.1	11.2		9.9	11.0			42
44													8.9	9.9		8.8	9.8			44
46													7.8	8.7		7.8	8.7			46
48													6.8	7.6		6.8	7.7			48
50													5.9	6.5		6.0	6.7			50
52													5.0	5.6		5.2	5.8			52
54													4.2	4.8		4.5	5.0			54
56													3.5	4.0		3.8	4.3			56
58													2.8	3.2		3.2	3.6			58
60													2.1	2.5		2.5	2.9			60
62																1.8	2.3			62
64																	1.7			64
66																				66
68																				68
70																				70

*adapter 2.5m+telescopic boom extension 3.5m

- Prerequisites:**
- ① Boom operating conditions(boom length + adapter+ jib length), max.length is 65.6m+6m+12m
 - ② The span of outriggers is 8.95m×8.6m
 - ③ 360°rotation is applied
 - ④ Counterweight is 100T
 - ⑤ Superlift angle of one-side unfold is 45°

working range	Main boom+ Adapter+ Jib+ Superlift																		working range	
	40.4+6m*			45.4+6m*			50.5+6m*			55.5+6m*			60.6+6m*			65.6+6m*				
	0°	20°	40°	0°	20°	40°	0°	20°	40°	0°	20°	40°	0°	20°	40°	0°	20°	40°		
4																			4	
4.0																			4.0	
5																			5	
5																			5	
6																			6	
7																			7	
8																			8	
9																			9	
10																			10	
11																			11	
12																			12	
13																			13	
14											32.1								14	
16											30.4								16	
18											28.8			28.1				25.2	18	
20											27.3	18.3		27.1				24.6	20	
22											25.9	17.8	13.7	25.9	17.7			24.1	17.5	22
24											24.8	17.2	13.4	24.8	17.1	13.3	23.3	17.0		24
26											23.7	16.6	13.2	23.8	16.6	13.1	22.4	16.5	13.1	26
28											22.1	16.2	13.0	22.4	16.2	12.9	21.5	16.1	12.9	28
30											19.6	15.7	12.8	19.8	15.8	12.7	20.1	15.7	12.7	30
32											17.4	15.3	12.6	17.6	15.4	12.6	17.9	15.3	12.6	32
34											15.5	14.9	12.4	15.7	15.0	12.4	16.0	15.0	12.4	34
36											13.8	14.5	12.4	14.0	14.6	12.4	14.3	14.6	12.4	36
38											12.3	14.3	12.3	12.5	14.3	12.3	12.9	14.3	12.3	38
40											11.0	13.5	12.2	11.2	13.0	12.2	11.6	13.3	12.2	40
42											9.8	12.1	12.1	10.0	11.6	12.1	10.4	12.0	12.1	42
44											8.7	10.8	11.4	9.0	10.4	11.3	9.3	10.8	11.4	44
46											7.8	9.6	10.1	8.0	9.3	10.1	8.3	9.7	10.2	46
48											6.9	8.5	9.0	7.1	8.3	9.0	7.5	8.7	9.2	48
50											6.1	7.5	7.4	6.3	7.4	8.0	6.7	7.8	8.2	50
52											5.3	6.6		5.6	6.6	6.6	5.9	6.9	7.3	52
54											4.6	5.8		4.9	5.8		5.2	6.2	6.5	54
56											4.0	5.0		4.3	5.1		4.6	5.5	5.3	56
58											3.4	4.2		3.7	4.4		4.0	4.8		58
60											2.8	3.5		3.1	3.7		3.5	4.2		60
62											2.1	2.7		2.2	3.1		2.4	3.6		62
64															2.2			3.0		64
66																		2.0		66
68																				68
70																				70
72																				72
74																				74
76																				76
78																				78

*adapter 2.5m+telescopic boom extension 3.5m

- Prerequisites:**
- ① Boom operating conditions(boom length + adapter+ jib length), max.length is 65.6m+6m+18m
 - ② The span of outriggers is 8.95m×8.6m
 - ③ 360°rotation is applied
 - ④ Counterweight is 100T
 - ⑤ Superlift angle of one-side unfold is 45°

working range	Main boom+ Adapter+ Jib+ Superlift																		working range	
	40.4+6m*			45.4+6m*			50.5+6m*			55.5+6m*			60.6+6m*			65.6+6m*				
	0°	20°	40°	0°	20°	40°	0°	20°	40°	0°	20°	40°	0°	20°	40°	0°	20°	40°		
4																				4
4.0																				4.0
5																				5
5																				5
6																				6
7																				7
8																				8
9																				9
10																				10
11																				11
12																				12
13																				13
14																				14
16																				16
18																				18
20																				20
22																				22
24																				24
26																				26
28																				28
30																				30
32																				32
34																				34
36																				36
38																				38
40																				40
42																				42
44																				44
46																				46
48																				48
50																				50
52																				52
54																				54
56																				56
58																				58
60																				60
62																				62
64																				64
66																				66
68																				68
70																				70
72																				72
74																				74
76																				76
78																				78

*adapter 2.5m+telescopic boom extension 3.5m

- Prerequisites:**
- ① Boom operating conditions(boom length + adapter + jib length), max.length is 65.6m+6m+24m
 - ② The span of outriggers is 8.95m×8.6m
 - ③ 360°rotation is applied
 - ④ Counterweight is 100T
 - ⑤ Superlift angle of one-side unfold is 45°

working range	Main boom+ Adapter+ Jib+ Superlift																		working range	
	40.4+6m*			45.4+6m*			50.5+6m*			55.5+6m*			60.6+6m*			65.6+6m*				
	0°	20°	40°	0°	20°	40°	0°	20°	40°	0°	20°	40°	0°	20°	40°	0°	20°	40°		
4																			4	
4.0																			4.0	
5																			5	
5																			5	
6																			6	
7																			7	
8																			8	
9																			9	
10																			10	
11																			11	
12																			12	
13																			13	
14	18.2				18.4														14	
16	17.0				17.3			17.3											16	
18	15.9				16.2			16.2			16.2								18	
20	14.9				15.3			15.4			15.5		15.2			14.6			20	
22	14.1	9.3			14.3			14.5			14.6		14.4			14.0			22	
24	13.2	8.9			13.6	9.0		13.8	9.1		14.0		13.8			13.4			24	
26	12.4	8.6			12.8	8.6		13.1	8.8		13.3	8.9	13.2			12.8			26	
28	11.8	8.2	5.9		12.2	8.4		12.4	8.5		12.7	8.6	12.6	8.6		12.4	8.5		28	
30	11.0	7.8	5.7	11.6	8.0	5.8		11.9	8.2	5.8	12.2	8.3	12.2	8.3		11.9	8.2		30	
32	10.5	7.4	5.5	11.0	7.7	5.6		11.3	7.8	5.6	11.6	8.0	5.7	11.6	8.0	5.7	11.4	7.9		32
34	9.9	7.1	5.4	10.5	7.4	5.4		10.8	7.5	5.5	11.1	7.7	5.5	11.2	7.7	5.5	11.0	7.7	5.5	34
36	9.3	6.8	5.2	10.0	7.1	5.3		10.4	7.2	5.4	10.6	7.4	5.4	10.7	7.5	5.4	10.6	7.4	5.4	36
38	8.9	6.6	5.1	9.5	6.8	5.2		9.9	7.0	5.2	10.3	7.1	5.3	10.4	7.2	5.3	10.3	7.2	5.3	38
40	8.5	6.4	4.9	9.0	6.6	5.0		9.5	6.7	5.1	9.8	6.9	5.2	10.0	7.0	5.2	9.7	7.0	5.2	40
42	8.0	6.1	4.8	8.6	6.4	4.9		9.0	6.6	5.0	9.4	6.7	5.0	9.5	6.7	5.1	8.9	6.7	5.1	42
44	7.6	5.9	4.8	8.2	6.2	4.8		8.6	6.3	4.9	8.6	6.5	4.9	8.7	6.6	5.0	8.1	6.6	5.0	44
46	7.2	5.7	4.7	7.8	5.9	4.8		8.3	6.1	4.8	7.8	6.3	4.9	7.9	6.4	4.9	7.4	6.5	4.9	46
48	6.8	5.5	4.7	7.4	5.7	4.7		7.7	5.9	4.8	7.1	6.1	4.8	7.2	6.2	4.8	6.7	6.3	4.8	48
50	6.6	5.4	4.4	7.1	5.6	4.7		7.0	5.8	4.7	6.4	5.9	4.8	6.5	6.0	4.8	6.1	6.1	4.8	50
52	6.3	5.2		6.7	5.4	4.6		6.3	5.6	4.7	5.8	5.8	4.7	5.9	5.9	4.8	5.6	5.9	4.8	52
54	6.0	5.0		6.3	5.3	4.4		5.7	5.4	4.6	5.3	5.6	4.7	5.4	5.7	4.7	5.1	5.4	4.7	54
56	5.7	4.9		5.7	5.1			5.2	5.3	4.4	4.8	5.5	4.6	4.9	5.6	4.6	4.6	4.9	4.6	56
58	5.4	4.8		5.1	5.0			4.6	5.0		4.3	5.1	4.6	4.4	5.2	4.6	4.2	4.5	4.6	58
60	5.2	4.6		4.6	4.9			4.2	4.5		3.9	4.6	4.2	4.0	4.7	4.5	3.8	4.1	4.5	60
62	4.6	4.5		4.0	4.7			3.7	4.0		3.4	4.1		3.5	4.2	4.5	3.4	3.7	4.5	62
64	4.2			3.4	3.8			3.3	3.5		3.1	3.6		2.9	3.8	4.2	3.0	3.3	4.4	64
66	2.5			2.8				2.6	3.1		2.5	3.2		2.6	3.4		2.5	3.0	4.0	66
68				2.0				1.8	2.7		1.8	2.7		1.8	2.8		1.9	2.7	3.1	68
70								1.7				2.0			2.4			2.4		70
72														1.6				1.8		72
74																				74
76																				76
78																				78

*adapter 2.5m+telescopic boom extension 3.5m

- Prerequisites:**
- ① Boom operating conditions(boom length + adapter+ jib length), max.length is 65.6m+6m+30m
 - ② The span of outriggers is 8.95m×8.6m
 - ③ 360°rotation is applied
 - ④ Counterweight is 100T
 - ⑤ Superlift angle of one-side unfold is 45°

working range	Main boom+ Adapter+ Jib+ Superlift																		working range	
	40.4+6m*			45.4+6m*			50.5+6m*			55.5+6m*			60.6+6m*			65.6+6m*				
	0°	20°	40°	0°	20°	40°	0°	20°	40°	0°	20°	40°	0°	20°	40°	0°	20°	40°		
4																				4
4.0																				4.0
5																				5
5																				5
6																				6
7																				7
8																				8
9																				9
10																				10
11																				11
12																				12
13																				13
14	14.2																			14
16	13.3							13.3												16
18	12.4							12.4						12.4			12.4			18
20	11.7							11.8						11.8			11.8			20
22	10.9							11.1						11.1			11.2		11.6	22
24	10.4							10.5						10.5			10.6		10.6	24
26	9.8	6.7						10.0	6.7					10.1			10.2		10.5	26
28	9.2	6.3						9.5	6.4					9.6	6.5		9.7	6.6	9.6	28
30	8.7	6.0						9.0	6.1					9.2	6.2		9.3	6.3	9.2	30
32	8.3	5.7	4.0					8.6	5.8					8.7	5.9		8.9	6.0	8.8	32
34	7.9	5.4	3.9	8.2	5.5	3.9		8.4	5.6					8.6	5.7		8.6	5.7	8.6	34
36	7.4	5.1	3.7	7.8	5.3	3.8		8.0	5.4	3.8				8.2	5.5	3.8	8.2	5.5	8.2	36
38	7.0	4.9	3.6	7.4	5.0	3.6		7.6	5.2	3.7				7.8	5.3	3.7	7.9	5.3	7.9	38
40	6.7	4.8	3.5	7.0	4.8	3.5		7.3	4.9	3.6				7.5	5.1	3.6	7.5	5.1	7.5	40
42	6.3	4.6	3.4	6.7	4.7	3.4		6.9	4.8	3.5				7.1	4.9	3.5	7.2	4.9	7.2	42
44	5.9	4.4	3.3	6.3	4.5	3.3		6.7	4.7	3.4				6.8	4.8	3.4	6.9	4.8	6.9	44
46	5.6	4.2	3.2	6.0	4.4	3.2		6.3	4.5	3.3				6.6	4.6	3.3	6.7	4.7	6.7	46
48	5.3	4.1	3.1	5.7	4.2	3.2		6.0	4.3	3.2				6.3	4.4	3.2	6.5	4.5	6.5	48
50	5.0	3.9	3.1	5.4	4.0	3.1		5.7	4.2	3.1				5.9	4.3	3.2	5.9	4.4	6.0	50
52	4.8	3.8	3.0	5.1	3.9	3.0		5.4	4.0	3.1				5.4	4.2	3.1	5.8	4.2	6.0	52
54	4.5	3.6	3.0	4.9	3.8	3.0		5.0	3.9	3.0				4.9	4.0	3.1	5.6	4.1	6.0	54
56	4.3	3.5	2.6	4.7	3.6	3.0		4.5	3.8	3.0				4.5	3.9	3.0	5.1	4.0	6.0	56
58	4.1	3.4		4.3	3.5	2.9		4.1	3.7	3.0				4.1	3.8	3.0	4.8	3.8	6.0	58
60	3.9	3.3		3.9	3.4	2.6		3.8	3.5	2.9				3.7	3.7	2.9	4.6	3.7	6.0	60
62	3.7	3.2		3.5	3.3			3.4	3.4	2.6				3.4	3.6	2.9	4.3	3.6	6.0	62
64	3.5	3.1		3.2	3.2			3.1	3.4					3.1	3.5	2.9	3.9	3.5	6.0	64
66	3.3	3.1		2.9	3.2			2.8	3.3					2.8	3.4	2.6	3.5	3.4	6.0	66
68	3.2			2.6	3.1			2.5	3.2					2.2	3.3		3.1	3.4	6.0	68
70	2.6			2.3	3.1			1.9	2.8					1.6	2.9		2.6	3.3	6.0	70
72				1.6					2.3						2.4		2.3	3.2</		

- Prerequisites:**
- ① Boom operating conditions(boom length + adapter+ jib length), max.length is 65.6m+6m+36m
 - ② The span of outriggers is 8.95m×8.6m
 - ③ 360°rotation is applied
 - ④ Counterweight is 100T
 - ⑤ Superlift angle of one-side unfold is 45°

working range	Main boom+ Adapter+ Jib+ Superlift																		working range	
	40.4+6m*			45.4+6m*			50.5+6m*			55.5+6m*			60.6+6m*			65.6+6m*				
	0°	20°	40°	0°	20°	40°	0°	20°	40°	0°	20°	40°	0°	20°	40°	0°	20°	40°		
4																			4	
4.0																			4.0	
5																			5	
5																			5	
6																			6	
7																			7	
8																			8	
9																			9	
10																			10	
11																			11	
12																			12	
13																			13	
14																			14	
16	10.6																		16	
18	10.0				10.5														18	
20	9.4				9.8				9.4				9.8						20	
22	8.8				9.2				8.8				9.3			9.1			22	
24	8.3				8.7				8.5				8.8			8.7			24	
26	7.9				8.3				8.0				8.5			8.3			26	
28	7.4	4.9			7.9				7.6				8.0			8.0			28	
30	7.0	4.7			7.5	5.1			7.2				7.7			7.6			30	
32	6.7	4.4			7.1	4.8			6.9	4.9			7.3	5.0		7.3			32	
34	6.3	4.2			6.7	4.7			6.6	4.8			7.0	4.8		7.0	4.8		34	
36	5.9	4.0			6.5	4.5			6.3	4.6			6.7	4.6		6.7	4.6		36	
38	5.6	3.8	2.7		6.2	4.3			6.0	4.4			6.5	4.4		6.5	4.5		38	
40	5.3	3.6	2.6		5.9	4.1			5.7	4.2	2.9		6.2	4.3		6.2	4.3		40	
42	4.9	3.4	2.5		5.6	3.9			5.4	4.0	2.8		5.9	4.1	2.8	6.0	4.1	2.8	42	
44	4.7	3.2	2.4		5.3	3.7			5.1	3.8	2.7		5.7	3.9	2.8	5.8	3.9	2.8	44	
46	4.4	3.1	2.4		5.0	3.5			4.9	3.6	2.7		5.4	3.7	2.7	5.5	3.8	2.7	46	
48	4.2	3.0	2.3		4.8	3.4			4.7	3.5	2.6		5.2	3.6	2.6	5.3	3.6	2.6	48	
50	3.9	2.9	2.2		4.6	3.2			4.5	3.3	2.5		5.0	3.4	2.6	5.1	3.5	2.6	50	
52	3.7	2.8	2.2		4.3	3.1			4.2	3.2	2.5		4.8	3.3	2.5	4.9	3.4	2.5	52	
54	3.5	2.7	2.1		4.1	3.0			4.0	3.1	2.4		4.6	3.2	2.4	4.8	3.2	2.5	54	
56	3.3	2.6	2.1		3.9	2.9			3.8	3.0	2.4		4.4	3.1	2.4	4.5	3.1	2.4	56	
58	3.1	2.5	2.0		3.7	2.9			3.6	2.9	2.3		4.1	3.0	2.4	4.1	3.0	2.4	58	
60	2.9	2.5	2.0		3.5	2.8			3.4	2.9	2.3		3.8	2.9	2.3	3.8	2.9	2.3	60	
62	2.9	2.4	1.8		3.3	2.7			3.3	2.8	2.2		3.5	2.9	2.3	3.5	2.9	2.3	62	
64	2.7	2.3			3.1	2.6			3.1	2.7	2.2		3.2	2.8	2.2	3.2	2.9	2.3	64	
66	2.6	2.2			3.0	2.5			2.9	2.6	2.2		2.9	2.7	2.2	2.9	2.8	2.2	66	
68	2.5	2.2			2.8	2.5			2.7	2.6	1.9		2.6	2.6	2.2	2.6	2.7	2.2	68	
70	2.4	2.2			2.6	2.4			2.4	2.5			2.6	2.1	1.9	2.6	2.2	1.9	70	
72	2.3	1.9			2.3	2.3			1.8	2.4			2.5	1.9		2.6	2.1		72	
74	2.2				1.8	2.3			2.4				2.4			2.5	2.1		74	
76	1.8				2.0				2.0				2.0			1.8	1.9		76	
78																			2.1	78
80																			1.6	80
82																				82
84																				84

*adapter 2.5m+telescopic boom extension 3.5m

- Prerequisites:**
- ① Boom operating conditions(boom length + adapter+ jib length), max.length is 60.5m+6m+42m
 - ② The span of outriggers is 8.95m×8.6m
 - ③ 360°rotation is applied
 - ④ Counterweight is 100T
 - ⑤ Superlift angle of one-side unfold is 45°

working range	Main boom+ Adapter+ Jib+ Superlift																		working range
	40.4+6m*			45.4+6m*			50.5+6m*			55.5+6m*			60.6+6m*			65.6+6m*			
	0°	20°	40°	0°	20°	40°	0°	20°	40°	0°	20°	40°	0°	20°	40°	0°	20°	40°	
4																			4
4.0																			4.0
5																			5
5																			5
6																			6
7																			7
8																			8
9																			9
10																			10
11																			11
12																			12
13																			13
14																			14
16																			16
18	8.4																		18
20	7.9															7.9			20
22	7.4															7.5			22
24	7.0															7.1			24
26	6.6															6.7			26
28	6.3															6.4			28
30	5.9															6.1			30
32	5.6	3.8														5.8			32
34	5.3	3.6														5.5	3.7		34
36	5.0	3.4														5.2	3.5		36
38	4.8	3.2														5.0	3.3		38
40	4.5	3.0														4.8	3.2		40
42	4.3	2.9	2.1													4.6	3.0		42
44	4.0	2.8	2.0													4.4	2.9		44
46	3.8	2.7	1.9													4.2	2.9		46
48	3.6	2.6	1.8													4.0	2.7		48
50	3.4	2.5	1.8													3.8	2.6		50
52	3.1	2.4	1.7													3.6	2.5		52
54	3.0	2.3	1.7													3.4	2.4		54
56	2.9	2.2	1.6													3.2	2.3		56
58	2.7	2.1	1.6													3.1	2.2		58
60	2.6	2.0	1.5													3.0	2.1		60
62	2.5	1.9	1.5													2.9	2.1		62
64	2.3	1.8	1.4													2.7	2.0		64
66	2.2	1.8	1.4													2.6	1.9		66
68	2.1	1.7	1.1													2.5	1.9		68
70	2.0	1.6														2.4	1.8		70
72	1.9	1.6														2.3	1.7		72
74	1.8	1.5														2.2	1.7		74
76	1.7	1.3														2.1	1.6		76
78	1.6															2.0	1.5		78
80	1.3															1.9	1.4		80
82																1.8	1.3		82
84																1.7	1.2		84
86																1.6	1.1		86
88																1.5	1.1		88
90																1.4			90

*adapter 2.5m+telescopic boom extension 3.5m

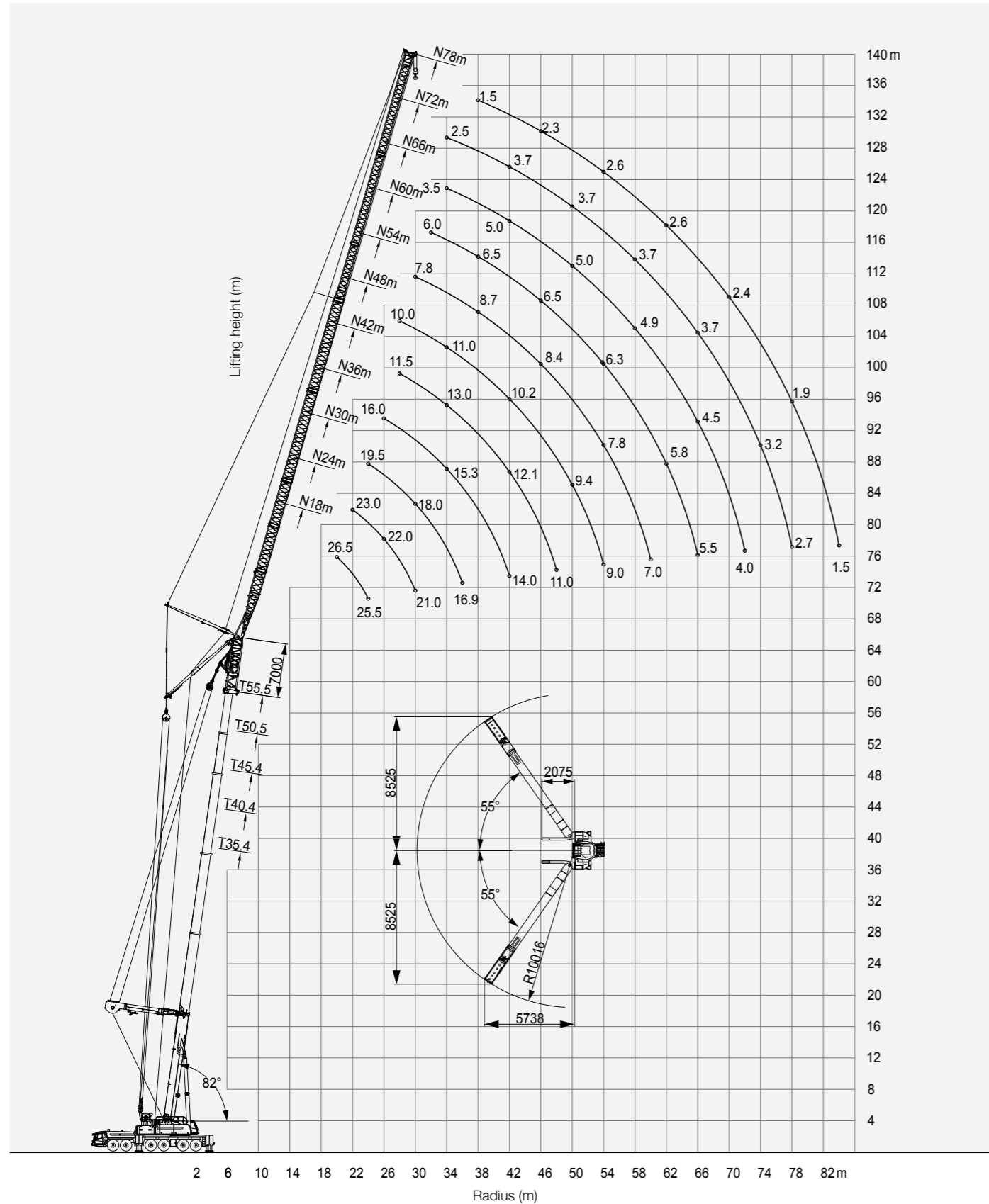

Prerequisites:

- ① Boom operating conditions(boom length + adapter+ tower jib length), max. length is 65.6m+7m+18m
- ② The span of outriggers is 8.95m×8.6m
- ③ 360°rotation is applied
- ④ Counterweight is 100T
- ⑤ Superlift angle of one-side unfold is 55°

working range	Main boom + Adapter + Tower jib + Superlift																		working range			
	35.4+7m*			40.4+7m*			45.4+7m*			50.5+7m*			55.5+7m*			60.6+7m*				65.6+7m*		
	82°	75°	68°	82°	75°	68°	82°	75°	68°	82°	75°	68°	82°	75°	68°	82°	75°	68°				
12																					12	
13																						13
14	37.5																					14
16	41.0			40.0																		16
18	44.0			41.0			37.0			32.5												18
20	44.0			40.0			36.5			32.0			26.5			24.5						20
22	41.1	37.0		37.1			36.0			31.2			26.0			23.5			21.0			22
24		33.1			32.1		34.1			30.0			25.5			23.0			20.0			24
26		29.9			29.0		28.6								22.5			19.5				26
28			24.6		26.3		26.0					25.3										28
30			22.5									23.2						21.2				30
32						19.7											19.4					32
34								16.5													14.5	34
36												14.7										36
38																						38
40																		7.6				40
42																						42
44																						44

*adapter 3.5m+telescopic boom extension 3.5m
**The weight of hanger is no less than 1500KG.

Prerequisites:

- ① Boom operating conditions(boom length + adapter+ tower jib length), max.length is 65.6m+7m+24m
- ② The span of outriggers is 8.95m×8.6m
- ③ 360°rotation is applied
- ④ Counterweight is 100T
- ⑤ Superlift angle of one-side unfold is 55°

working range	Main boom+ Adapter+ Tower jib+ Superlift																		working range					
	35.4+7m*			40.4+7m*			45.4+7m*			50.5+7m*			55.5+7m*			60.6+7m*				65.6+7m*				
	82°	75°	68°	82°	75°	68°	82°	75°	68°	82°	75°	68°	82°	75°	68°	82°	75°	68°		82°	75°	68°		
13																							13	
14																								14
16	29.9																							16
18	31.9			31.0																				18
20	34.0			32.1			29.0			26.5														20
22	34.5			32.0			29.0			26.0		23.0		20.0										22
24	34.0	34.0		31.0			29.0			25.2		22.1		19.5			17.5							24
26	32.0	31.6		29.0	28.9		28.5			25.0		22.0		19.2			16.5							26
28	30.9	28.8		27.3	27.1		28.0			24.1		21.3		19.0			16.0							28
30		26.4			25.5		26.9	25.1		23.0	22.8		21.0			18.0								30
32		24.3	21.8		23.5			23.2		21.1			19.2			17.2								32
34			20.2		21.7	17.9		21.4			19.5			17.8			17.0							34
36			18.7			16.6				18.1				16.5			16.0				13.5			36
38					15.5					16.0				15.3			15.1				12.2			38
40										14.2			12.5								11.5			40
42												11.7			9.6									42
44														9.0										44
46															6.5									46
48															6.5									48
50																						6.5		50
52																								52
54																								54
56																								56

*adapter 3.5m+telescopic boom extension 3.5m

Prerequisites:

- ① Boom operating conditions(boom length + adapter+ tower jib length), max.length is 65.6m+7m+30m
- ② The span of outriggers is 8.95m×8.6m
- ③ 360°rotation is applied
- ④ Counterweight is 100T
- ⑤ Superlift angle of one-side unfold is 55°

working range	Main boom+ Adapter+ Tower jib+ Superlift																		working range					
	35.4+7m*			40.4+7m*			45.4+7m*			50.5+7m*			55.5+7m*			60.6+7m*				65.6+7m*				
	82°	75°	68°	82°	75°	68°	82°	75°	68°	82°	75°	68°	82°	75°	68°	82°	75°	68°		82°	75°	68°		
16																								16
18	25.6																							18
20	26.2																							20
22	28.0			26.0																				22
24	29.0			27.0			24.5																	24
26	28.5			26.6			24.0																	26
28	28.0	28.0		25.8			24.0																	28
30	27.1	27.0		24.5	24.0		23.1																	30
32	25.0	25.9		23.8	22.1		22.9	22.1																32
34	23.6	24.9		21.9	21.2		21.1	21.0																34
36		23.3	18.4		20.0		20.0	19.6																36
38		21.7	17.2		18.6	15.2		18.3																38
40			16.1		17.4	14.2		17.1	16.5															40
42			15.0			13.3			15.5															42
44						12.4			14.4															44
46									13.7															46
48																								48
50																								50
52																								52
54																								54
56																								56

*adapter 3.5m+telescopic boom extension 3.5m

- Prerequisites:**
- ① Boom operating conditions(boom length + adapter+ tower jib length), max.length is 65.6m+7m+36m
 - ② The span of outriggers is 8.95m×8.6m
 - ③ 360°rotation is applied
 - ④ Counterweight is 100T
 - ⑤ Superlift angle of one-side unfold is 55°

working range	Main boom+ Adapter+ Tower jib+ Superlift																		working range					
	35.4+7m*			40.4+7m*			45.4+7m*			50.5+7m*			55.5+7m*			60.6+7m*				65.6+7m*				
	82°	75°	68°	82°	75°	68°	82°	75°	68°	82°	75°	68°	82°	75°	68°	82°	75°	68°		82°	75°	68°		
16																							16	
18																								18
20	21.5																							20
22	22.0			21.5			15.9																	22
24	23.1			22.0			18.4			17.5														24
26	23.9			22.0			20.0			18.5		16.0		14.0										26
28	23.5			22.0			20.0			18.0		15.8		13.5			12.5							28
30	23.0	23.0		22.0			20.0			18.0		15.8		13.5			12.0							30
32	22.7	23.0		21.5	20.5		19.8			18.0		15.3		13.5			12.0							32
34	21.0	22.0		20.5	19.5		19.5	19.0		17.6		15.3		13.2			11.3							34
36	20.8	21.0		19.6	19.1		19.0	18.9		17.0	16.9		15.0		13.0			11.1						36
38	19.9	20.6	16.8	18.7	18.0		18.6	18.0		16.6	16.3		14.6	14.1		12.7	12.1							38
40	18.9	19.5	15.7	17.6	17.1	13.8	18.0	16.8		16.2	15.3		14.2	13.8		12.5	12.0							40
42		18.6	14.8		16.0	13.0	17.0	15.8		16.0	14.3		14.0	13.0		12.3	12.0			10.4	10.0			42
44		17.6	13.9		15.1	12.2		14.8	14.2		13.5			12.2	12.0	11.5	9.5	9.5						44
46			13.0		14.0	11.5		14.0	13.4		12.7	9.7		11.5			11.2			9.0				46
48			12.3			10.8			12.7		11.9	9.2		10.8			10.5			8.5				48
50						10.2			12.0			8.7	10.2	7.0	9.6	3.5			8.1					50
52												11.3			8.2		6.6		3.5	7.8				52
54																7.7		6.3		3.5			4.0	54
56																	5.9		3.5				4.0	56
58																			3.5				4.0	58
60																							3.6	60
62																								62

*adapter 3.5m+telescopic boom extension 3.5m

- Prerequisites:**
- ① Boom operating conditions(boom length + adapter+ tower jib length), max.length is 65.6m+7m+42m
 - ② The span of outriggers is 8.95m×8.6m
 - ③ 360°rotation is applied
 - ④ Counterweight is 100T
 - ⑤ Superlift angle of one-side unfold is 55°

working range	Main boom+ Adapter+ Tower jib+ Superlift																		working range					
	35.4+7m*			40.4+7m*			45.4+7m*			50.5+7m*			55.5+7m*			60.6+7m*				65.6+7m*				
	82°	75°	68°	82°	75°	68°	82°	75°	68°	82°	75°	68°	82°	75°	68°	82°	75°	68°		82°	75°	68°		
20																								20
22	19.5						17.5																	22
24	19.8						17.8						15.0											24
26	20.0						18.2						16.0			13.3								26
28	19.7						18.8						16.8			14.5		11.5			11.4			28
30	19.3						18.5						16.8			15.0		13.0			11.3			30
32	18.5	19.0					18.0						16.8			15.0		13.0			11.2			32
34	17.8	18.8					17.7	18.0					13.6			15.0		13.0			11.1			34
36	16.9	18.2					17.2	17.6					16.0	16.0		14.5		13.0			11.0			36
38	15.8	17.4					16.5	16.7					15.8	15.7		14.2	13.7			12.5			10.9	38
40	15.0	16.7					15.6	16.0					15.5	15.4		14.0	13.5			12.3			10.7	40
42	14.2	16.0	15.0				14.8	15.3					15.0	15.1		13.6	13.3			12.1	12.0			42
44	13.5	15.2	14.5	14.1	14.5	12.7	14.0	14.5					13.3	12.8		11.9	11.8			10.2	10.0			44
46	13.0	14.4	13.9	13.5	14.0	11.9	13.5	13.7	13.1	13.1	12.3				11.5	11.2			10.1	10.0			46	
48		13.6	13.4		12.9	11.2	13.0	12.9	12.3	13.0	11.7				11.0	10.6			10.0	9.5			48	
50		12.9	12.8		12.3	10.6		12.2	11.7	0.0	11.1	7.2			10.0			9.0	9.4				50	
52			12.1		11.5	10.0		11.6	11.1		10.5	6.8			9.5			9.2					52	
54			11.4			9.5			10.5		9.9	6.4			8.9	5.5		8.7	3.1				54	
56						8.9			10.0			6.1			8.4	5.2		8.2	3.1				56	
58												5.7				4.9			3.1				58	
60												5.4				4.7			2.8				60	
62																4.4			2.8				62	
64																			2.8				64	
66																							66	
68																							68	

*adapter 3.5m+telescopic boom extension 3.5m

- Prerequisites:**
- ① Boom operating conditions(boom length + adapter+ tower jib length), max.length is 60.6m+7m+48m
 - ② The span of outriggers is 8.95m×8.6m
 - ③ 360°rotation is applied
 - ④ Counterweight is 100T
 - ⑤ Superlift angle of one-side unfold is 55°

working range	Main boom+ Adapter+ Tower jib+ Superlift																		working range				
	35.4+7m*			40.4+7m*			45.4+7m*			50.5+7m*			55.5+7m*			60.6+7m*				65.6+7m*			
	82°	75°	68°	82°	75°	68°	82°	75°	68°	82°	75°	68°	82°	75°	68°	82°	75°	68°		82°	75°	68°	
22																							22
24	15.2			13.5																			24
26	15.5			14.0			13.0																26
28	16.0			14.5			13.5			11.6			10.0										28
30	16.0			15.0			13.5			12.0			10.3			9.3							30
32	15.8			15.0			13.5			12.5			10.6			9.5							32
34	15.6	15.5		15.0			13.5			12.5			11.0			9.5							34
36	15.3	15.4		15.0	14.0		13.5			12.5			10.8			9.5							36
38	15.1	15.3		15.0	14.0		13.5	13.0		12.5			10.6			9.5							38
40	14.9	15.2		14.8	14.0		13.5	13.0		12.0	11.5		10.4			9.3							40
42	14.7	15.0		14.5	14.0		13.3	13.0		11.9	11.4		10.2	10.0		9.2							42
44	14.3	14.3	13.7	14.2	13.5		13.1	13.0		11.7	11.3		10.0	9.8		9.1	8.5						44
46	13.5	13.6	13.0	13.8	13.0		12.9	12.7		11.5	11.2		9.8	9.7		8.9	8.5						46
48	12.9	12.8	12.3	13.3	12.5	10.9	12.7	12.3		11.3	11.1		9.6	9.6		8.7	8.4						48
50	12.2	12.3	11.9	12.5	12.0	10.3	12.5	11.8	11.0	11.1	10.8		9.4	9.5		8.5	8.3						50
52	11.3	11.9	11.4	11.5	11.5	9.7	12.0	11.3	10.4	10.9	10.2	6.5	9.2	9.4		8.3	8.2						52
54		11.3	11.0		11.0	9.2	11.0	10.7	10.0	10.7	9.7	6.2	9.0	9.2		8.1	8.0						54
56		10.7	10.6		10.4	8.7		10.2	9.6		9.2	5.8		8.9	5.0	7.8	7.8						56
58			10.0		9.8	8.2		9.6	9.2		8.7	5.5		8.4	4.7		7.6	2.3					58
60			9.5			7.8			8.8		8.2	5.2		8.0	4.5		7.2	2.5					60
62					7.4				8.3			4.9		7.5	4.2		6.8	2.5					62
64									7.9			4.7			4.0			2.5					64
66											4.4				3.8			2.5					66
68														3.6				2.5					68
70																		2.2					70
72																							72

*adapter 3.5m+telescopic boom extension 3.5m

- Prerequisites:**
- ① Boom operating conditions(boom length + adapter+ tower jib length), max.length is 55.5m+7m+54m
 - ② The span of outriggers is 8.95m×8.6m
 - ③ 360°rotation is applied
 - ④ Counterweight is 100T
 - ⑤ Superlift angle of one-side unfold is 55°

working range	Main boom+ Adapter+ Tower jib+ Superlift																		working range				
	35.4+7m*			40.4+7m*			45.4+7m*			50.5+7m*			55.5+7m*			60.6+7m*				65.6+7m*			
	82°	75°	68°	82°	75°	68°	82°	75°	68°	82°	75°	68°	82°	75°	68°	82°	75°	68°		82°	75°	68°	
24																							24
26	12.0			11.5																			26
28	12.5			11.7			10.0																28
30	12.6			11.9			10.4			9.0			7.8										30
32	12.7			11.9			10.8			9.5			8.3										32
34	12.7			11.9			11.0			9.8			8.5										34
36	12.6	12.0		11.9			11.0			10.0			8.7										36
38	12.5	12.0		11.9	11.6		11.0			10.0			8.7										38
40	12.4	12.0		11.9	11.6		11.0	11.0		10.0			8.7										40
42	12.2	12.0		11.9	11.6		11.0	11.0		10.0	9.5		8.5										42
44	12.0	11.9		11.7	11.6		11.0	10.8		9.7	9.5		8.5										44
46	11.9	11.8		11.5	11.3		10.8	10.6		9.6	9.5		8.4	8.0									46
48	11.8	11.7	11.0	11.0	10.8		10.6	10.4		9.5	9.4		8.2	8.0									48
50	11.7	11.5	11.0	10.5	10.3	9.5	10.4	10.2		9.4	9.3		8.1	7.8									50
52	11.3	11.3	10.6	10.0	9.8	9.2	10.2	10.0	9.5	9.2	9.2		8.0	7.7									52
54	10.6	10.5	10.2	9.5	9.3	8.8	10.0	9.8	9.3	8.6	9.1		7.8	7.7									54
56	10.0	9.9	9.8	9.0	9.0	8.3	10.0	9.5	9.1	8.1	9.0	5.5	7.6	7.7									56
58	9.5	9.7	9.4	8.5	8.7	7.8	9.7	9.2	8.7	7.7	8.9	5.2	7.3	7.7	4.4								58
60		9.4	9.0		8.2	7.4	9.3	8.8	8.3	7.2	8.5	4.9	7.0	7.5	4.2								60
62		9.0	8.6		7.7	7.0		8.4	8.0		8.0	4.6		7.2	3.9								62
64			8.2		7.3	6.7		7.9	7.6		7.6	4.4		6.9	3.7								64
66			7.7			6.3			7.2		7.2	4.1		6.5	3.5								66
68						6.0			6.8			3.9		6.1	3.3								68
70									6.4			3.7			3.1								70
72												3.5			2.9								72
74															2.7								74
76																							76

*adapter 3.5m+telescopic boom extension 3.5m

- Prerequisites:**
- ① Boom operating conditions(boom length + adapter+ tower jib length), max.length is 55.5m+7m+60m
 - ② The span of outriggers is 8.95m×8.6m
 - ③ 360°rotation is applied
 - ④ Counterweight is 100T
 - ⑤ Superlift angle of one-side unfold is 55°

working range	Main boom+ Adapter+ Tower jib+ Superlift																		working range					
	35.4+7m*			40.4+7m*			45.4+7m*			50.5+7m*			55.5+7m*			60.6+7m*				65.6+7m*				
	82°	75°	68°	82°	75°	68°	82°	75°	68°	82°	75°	68°	82°	75°	68°	82°	75°	68°		82°	75°	68°		
22																							22	
24																								24
26																								26
28	9.2			9.1																				28
30	9.3			9.2			8.0			7.0														30
32	9.4			9.3			8.2			7.3			6.0											32
34	9.5			9.4			8.4			7.5			6.2											34
36	9.7			9.5			8.6			7.7			6.5											36
38	9.9			9.6			8.6			7.7			6.5											38
40	9.8	9.5		9.6			8.6			7.7			6.5											40
42	9.7	9.5		9.6	9.5		8.6	9.0		7.7			6.5											42
44	9.7	9.5		9.6	9.5		8.6	8.8		7.7			6.5											44
46	9.6	9.5		9.5	9.5		8.6	8.7		7.7	7.7		6.5	6.3										46
48	9.5	9.5		9.4	9.5		8.6	8.6		7.7	7.6		6.5	6.3										48
50	9.4	9.5	8.6	9.3	9.5		8.5	8.6		7.7	7.5		6.5	6.3										50
52	9.3	9.4	8.6	9.2	9.3		8.4	8.5		7.5	7.4		6.5	6.3										52
54	9.2	9.3	8.6	9.1	9.1	8.0	8.3	8.4		7.4	7.3		6.3	6.2										54
56	9.1	9.2	8.6	9.0	8.8	7.7	8.2	8.3	7.6	7.3	7.2		6.2	6.1										56
58	9.0	9.1	8.6	8.7	8.5	7.4	8.1	8.2	7.3	7.2	7.1	4.9	6.1	6.0										58
60	8.8	8.8	8.4	8.2	8.1	7.1	8.0	8.0	7.0	7.1	7.0	4.6	6.0	5.9	1.8									60
62	8.5	8.5	8.1	7.8	7.6	6.7	7.7	7.7	6.8	7.0	6.9	4.3	5.8	5.8	1.9									62
64	8.2	8.2	7.8	7.1	7.1	6.3	7.3	7.3	6.6	6.8	6.8	4.1	5.6	6.6	2.0									64
66		7.8	7.4		6.7	6.0	6.8	6.9	6.4	6.6	6.6	3.9	5.5	5.6	2.0									66
68		7.3	6.9		6.3	5.7		6.6	6.2		6.4	3.6		5.4	2.0									68
70			6.5		5.9	5.3		6.2	6.0		6.1	3.4		5.2	2.0									70
72			6.2			5.0			5.7		5.8	3.2		4.9	2.0									72
74					4.8				5.4			3.0		4.6	2.0									74
76									5.1			2.9			2.0									76
78												2.7			1.7									78
80															1.4									80
82																								82
84																								84

*adapter 3.5m+telescopic boom extension 3.5m

- Prerequisites:**
- ① Boom operating conditions(boom length + adapter+ tower jib length), max.length is 55.5m+7m+66m
 - ② The span of outriggers is 8.95m×8.6m
 - ③ 360°rotation is applied
 - ④ Counterweight is 100T
 - ⑤ Superlift angle of one-side unfold is 55°

working range	Main boom+ Adapter+ Tower jib+ Superlift																		working range					
	35.4+7m*			40.4+7m*			45.4+7m*			50.5+7m*			55.5+7m*			60.6+7m*				65.6+7m*				
	82°	75°	68°	82°	75°	68°	82°	75°	68°	82°	75°	68°	82°	75°	68°	82°	75°	68°		82°	75°	68°		
26																								26
28	7.8																							28
30	8.0			6.8						6.3														30
32	8.0			6.9						6.5			5.5											32
34	8.0			7.0						6.7			5.7			3.5								34
36	8.0			7.1						6.7			5.9			4.0								36
38	8.0			7.3						6.7			5.9			4.5								38
40	8.0			7.5						6.7			5.9			5.0								40
42	7.9	7.5		7.5						6.7			5.9			5.0								42
44	7.9	7.6		7.5	7.5					6.7	6.8		5.9			5.0								44
46	7.8	7.6		7.5	7.5					6.7	6.8		5.9			5.0								46
48	7.8	7.6		7.5	7.5					6.7	6.8		5.9	5.9		5.0								48
50	7.7	7.6		7.5	7.5					6.7	6.8		5.9	5.9		5.0	4.9							50
52	7.6	7.6		7.5	7.5					6.7	6.7		5.9	5.9		5.0	4.9							52
54	7.5	7.4	7.0	7.5	7.5					6.7	6.7		5.9	5.9		5.0	4.8							54
56	7.4	7.3	7.0	7.5	7.5	6.5	6.4	6.5		5.9	5.9		5.0	4.8										56
58	7.3	7.2	6.9	7.3	7.5	6.8	6.3	6.4	6.0	5.8	5.7		4.9	4.7										58
60	7.2	7.1	6.7	7.1	7.3	6.4	6.2	6.3	5.9	5.7	5.6		4.8	4.7										60
62	7.1	7.0	6.5	6.9	7.0	6.2	6.1	6.2	5.7	5.6	5.4	4.1	4.7	4.6										62
64	7.0	6.8	6.3	6.8	6.7	6.0	5.9	6.0	5.5	5.5	5.4	3.8	4.6	4.6										64
66	6.7	6.2	6.1	6.7	6.5	5.6	5.7	5.8	5.3	5.4	5.3	3.6	4.5	4.5										66
68	6.3	5.8	5.9	6.3	6.1	5.3	5.5	5.7	5.1	5.2	5.2	3.4	4.4	4.5	1.2									68
70	5.8	5.5	5.6	6.0	5.7	5.0	5.2	5.5	4.8	5.0	5.1	3.2	4.2	4.4	1.4									70
72		5.2	5.3		5.4	4.7	4.9	5.3	4.6	4.7	5.0	3.0	4.0	4.3	1.5									72
74		4.9	5.0		5.1	4.5		5.0	4.4		4.8	2.8		4.2	1.5									74
76			4.7		4.8	4.2		4.7	4.2		4.6	2.6		4.1	1.5									76
78			4.5			4.0			4.0		4.4	2.5		4.0	1.5									78
80						3.7			3.8			2.3		3.7	1.4									80
82									3.6			2.1			1.2									82
84												2.0												84

*adapter 3.5m+telescopic boom extension 3.5m

- Prerequisites:**
- ① Boom operating conditions(boom length + adapter+ tower jib length), max.length is 55.5m+7m+72m
 - ② The span of outriggers is 8.95m×8.6m
 - ③ 360°rotation is applied
 - ④ Counterweight is 100T
 - ⑤ Superlift angle of one-side unfold is 55°

working range	Main boom+ Adapter+ Tower jib+ Superlift																		working range					
	35.4+7m*			40.4+7m*			45.4+7m*			50.5+7m*			55.5+7m*			60.6+7m*				65.6+7m*				
	82°	75°	68°	82°	75°	68°	82°	75°	68°	82°	75°	68°	82°	75°	68°	82°	75°	68°		82°	75°	68°		
26																							26	
28																								28
30	6.0																							30
32	6.0			5.2			4.9																	32
34	6.0			5.3			5.0			4.0			2.5											34
36	6.2			5.4			5.1			4.3			2.8											36
38	6.2			5.5			5.2			4.5			3.0											38
40	6.2			5.6			5.2			4.7			3.5											40
42	6.2			5.7			5.2			4.7			3.7											42
44	6.2	5.5		5.8			5.2			4.7			3.7											44
46	6.2	5.7		5.8	5.5		5.2			4.7			3.7											46
48	6.2	5.8		5.8	5.6		5.2	5.2		4.7			3.7											48
50	6.0	5.8		5.8	5.7		5.2	5.2		4.7	4.6		3.7											50
52	6.0	5.8		5.8	5.7		5.2	5.2		4.7	4.6		3.7	3.7										52
54	6.0	5.8		5.7	5.7		5.2	5.2		4.5	4.5		3.7	3.7										54
56	6.0	5.8	5.0	5.7	5.7		5.1	5.2		4.5	4.5		3.7	3.7										56
58	6.0	5.8	5.1	5.7	5.7		5.0	5.2		4.5	4.5		3.7	3.7										58
60	6.0	5.8	5.2	5.6	5.6	4.9	4.9	5.1		4.5	4.5		3.7	3.7										60
62	5.9	5.8	5.3	5.5	5.6	5.0	4.8	5.0	4.5	4.4	4.3		3.7	3.7										62
64	5.8	5.8	5.3	5.4	5.6	5.0	4.7	4.9	4.6	4.3	4.3	3.3	3.7	3.6										64
66	5.7	5.6	5.3	5.3	5.6	5.0	4.6	4.9	4.7	4.2	4.2	3.1	3.7	3.5										66
68	5.6	5.6	5.3	5.2	5.6	5.0	4.5	4.8	4.6	4.1	4.1	2.9	3.6	3.4										68
70	5.5	5.6	5.1	5.1	5.6	4.7	4.4	4.7	4.4	4.0	4.0	2.7	3.5	3.3										70
72	5.4	5.4	4.9	5.0	5.2	4.5	4.3	4.7	4.2	3.9	3.9	2.5	3.4	3.2										72
74	5.3	5.1	4.7	4.9	4.9	4.2	4.2	4.6	4.0	3.8	3.8	2.3	3.2	3.1										74
76	5.0	4.8	4.5	4.8	4.6	3.9	4.0	4.4	3.8	3.6	3.7	2.2	3.0	3.0										76
78		4.5	4.2		4.4	3.7	3.8	4.2	3.7	3.4	3.6	2.0	2.7	2.9										78
80		4.2	4.0		4.1	3.5		4.0	3.5		3.5	1.9	0.0	2.7										80
82			3.7		4.0	3.2		3.8	3.3		3.4	1.8		2.5										82
84			3.5			3.0			3.1		3.2	1.6		2.2										84
86					2.8				2.9			1.5		1.7										86
88									2.7			1.4												88
90												1.3												90
92																								92

*adapter 3.5m+telescopic boom extension 3.5m

- Prerequisites:**
- ① Boom operating conditions(boom length + adapter+ tower jib length), max.length is 55.5m+7m+78m
 - ② The span of outriggers is 8.95m×8.6m
 - ③ 360°rotation is applied
 - ④ Counterweight is 100T
 - ⑤ Superlift angle of one-side unfold is 55°

working range	Main boom+ Adapter+ Tower jib+ Superlift																		working range					
	35.4+7m*			40.4+7m*			45.4+7m*			50.5+7m*			55.5+7m*			60.6+7m*				65.6+7m*				
	82°	75°	68°	82°	75°	68°	82°	75°	68°	82°	75°	68°	82°	75°	68°	82°	75°	68°		82°	75°	68°		
28																								28
30																								30
32	4.6																							32
34	4.6			4.3			3.5																	34
36	4.6			4.3			3.5			2.8														36
38	4.6			4.4			3.6			2.8			1.5											38
40	4.6			4.4			3.6			3.0			1.6											40
42	4.6			4.4			3.7			3.2			1.8											42
44	4.6			4.4			3.7			3.3			2.0											44
46	4.6	4.4		4.4			3.8			3.3			2.3											46
48	4.5	4.4		4.3	4.1		3.8			3.3			2.5											48
50	4.5	4.4		4.3	4.1		3.9	3.9		3.3			2.5											50
52	4.5	4.4		4.2	4.2		3.9	3.9		3.3	3.3		2.5											52
54	4.4	4.4		4.1	4.3		3.8	3.9		3.3	3.3		2.6	2.7										54
56	4.4	4.4		4.1	4.3		3.8	3.9		3.3	3.3		2.6	2.7										56
58	4.3	4.4		4.0	4.3		3.7	3.9		3.3	3.3		2.6	2.7										58
60	4.3	4.4	3.7	4.0	4.3		3.7	3.9		3.3	3.3		2.6	2.7										60
62	4.2	4.4	3.7	4.0	4.3		3.6	3.9		3.2	3.2		2.6	2.7										62
64	4.2	4.4	3.9	4.0	4.3		3.6	3.9	3.3	3.1	3.1		2.6	2.6										64
66	4.1	4.4	4.1	3.9	4.3		3.5	3.9	3.4	3.0	3.0		2.6	2.6										66
68	4.1	4.3	4.1	3.8	4.2		3.4	3.8	3.4	2.9	3.0	2.5	2.6	2.4										68
70	4.0	4.2	4.1	3.7	4.1		3.3	3.7	3.4	2.8	3.0	2.4	2.4	2.4										70
72	3.9	4.1	4.1	3.6	4.0		3.2	3.7	3.4	2.7	3.0	2.2	2.2	2.3										72
74	3.9	4.0	4.0	3.5	3.8	3.3	3.1	3.6	3.3	2.6	3.0	2.1	2.1	2.3										74
76	3.8	3.9	3.9	3.4	3.6	3.1	2.9	3.6	3.2	2.5	3.0	1.9	2.0	2.3										76
78	3.8	3.8	3.8	3.3	3.4	3.0	2.8	3.6	3.1	2.4	2.8	1.8	1.9	2.2										78
80	3.7	3.7	3.6	3.2	3.2	2.8	2.7	3.5	3.0	2.3	2.8	1.6	1.8	2.2										80
82	3.5	3.6	3.4	3.1	3.0	2.5	2.5	3.4	2.9	2.2	2.8	1.5	1.7	2.2										82
84		3.5	3.2		2.8	1.8		3.3	2.8	2.0	2.8	1.4	1.5	2.2										84
86		3.3	3.0		2.6	1.1		3.2	2.7		2.8	1.2		2.2										86
88			2.8		2.3	2.3		3.0	2.6		2.7	1.1		2.1										88
90			2.6						2.4		2.6	1.0		2.0										90
92									2.2					2.0										92
94									2.0															94
96																								96

*adapter 3.5m+telescopic boom extension 3.5m

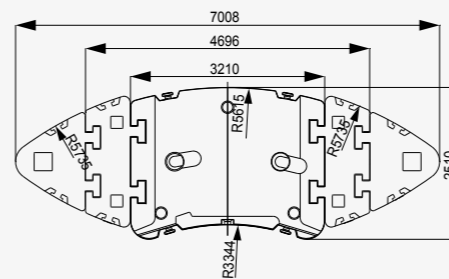
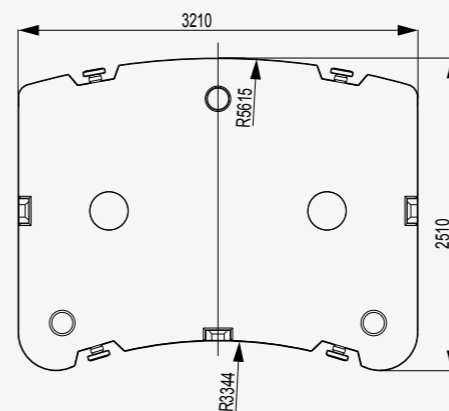
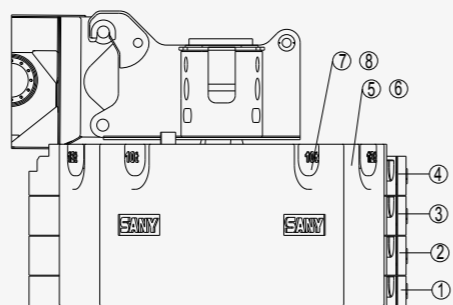
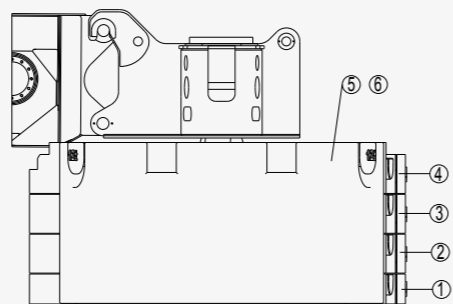
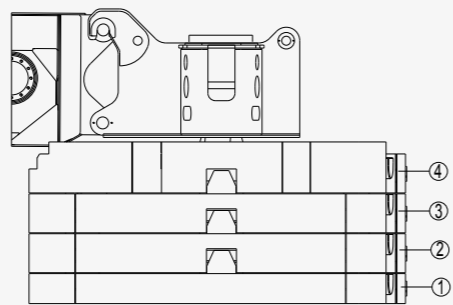
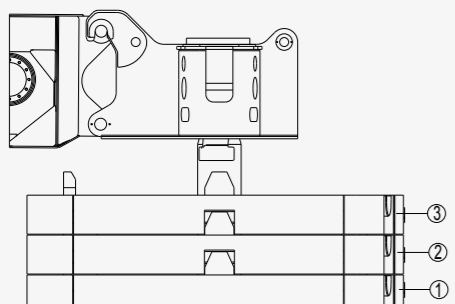
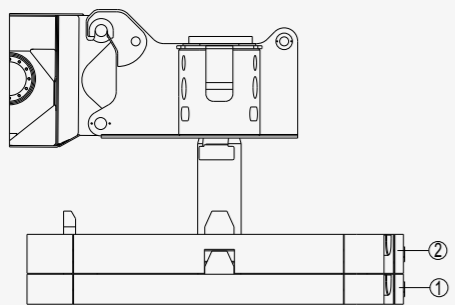
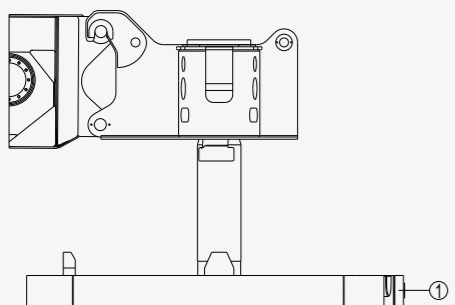
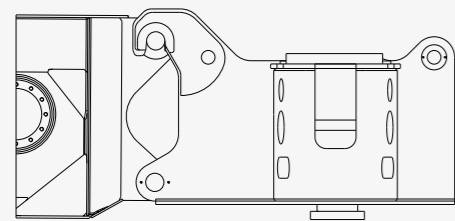



Quality Changes the World

SANY AUTOMOBILE HOISTING MACHINERY

Address: SANY Industrial Park, Jinzhou Development Zone,
Changsha, Hunan, China.
Service Hotline: 4006098318
Email: crd@sany.com.cn
For more information, please visit: www.sanygroup.com

For our consistent improvement in technology, specifications may change without notice.
The machines illustrated may show optional equipment which can be supplied at additional cost.

Version: 2015.08

Distributed By: