

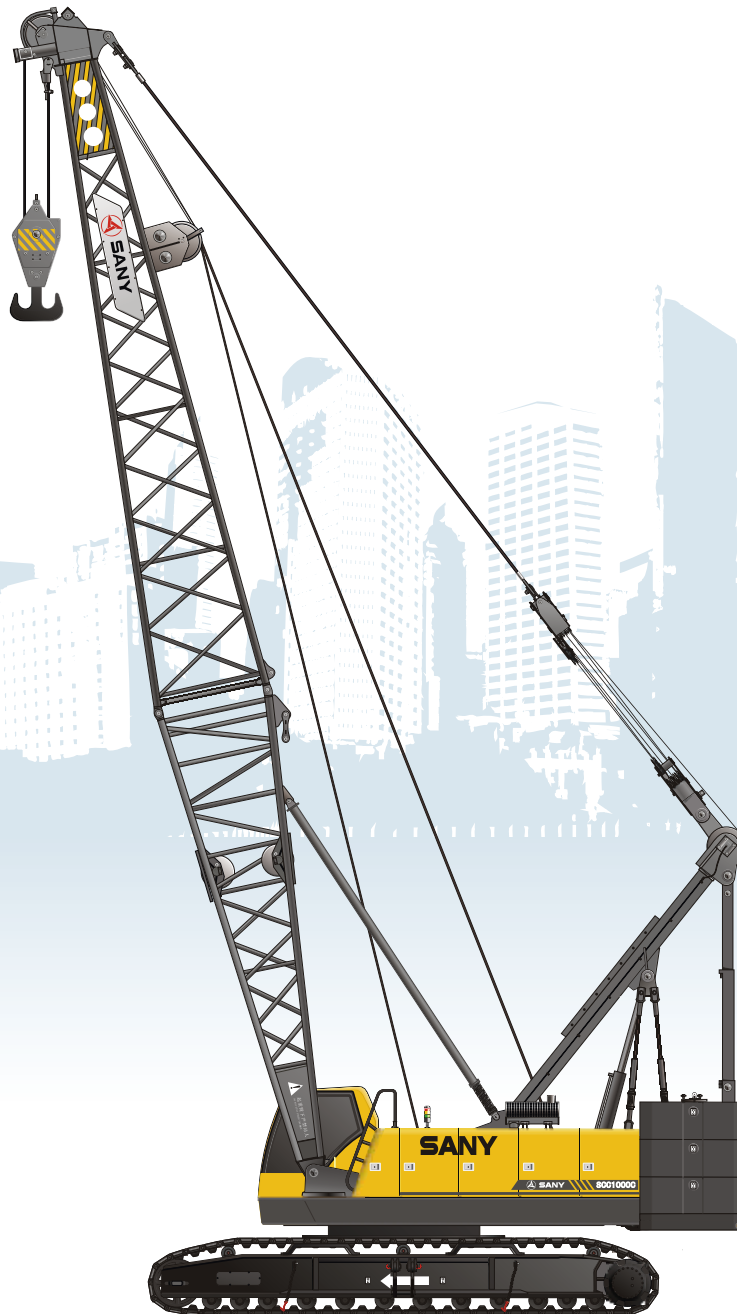

# SANY

Quality Changes the World



## **SANY CRAWLER CRANE SCC 1000C**

# CRAWLER CRANE CONTENT

## P3

### SCC1000C Crawler Crane

- Outline Dimensions
- Main Technical Features
- Performance Data
- Transport Dimensions
- Assembly Diagram

## P12

### Specifications

- Superworks
- Lowerworks
- Operation Device
- Safety Devices

## P20

### Operating Condition Combination

- Operating Condition Combination
- H Operating Condition
- FJ Operating Condition

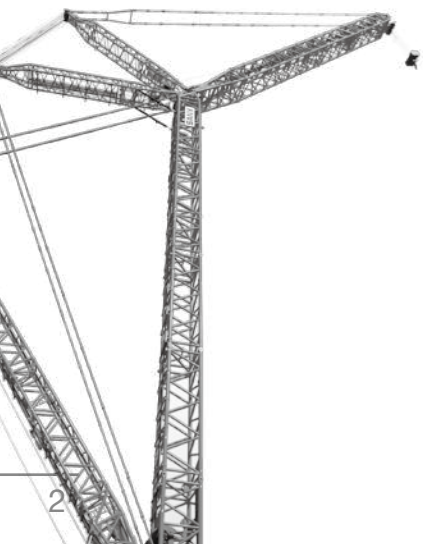

# SCC1000C

04	Outline Dimensions
05	Main Technical Features
06	Performance Data
07	Transport Dimensions
11	Assembly Diagram



## OUTLINE DIMENSIONS

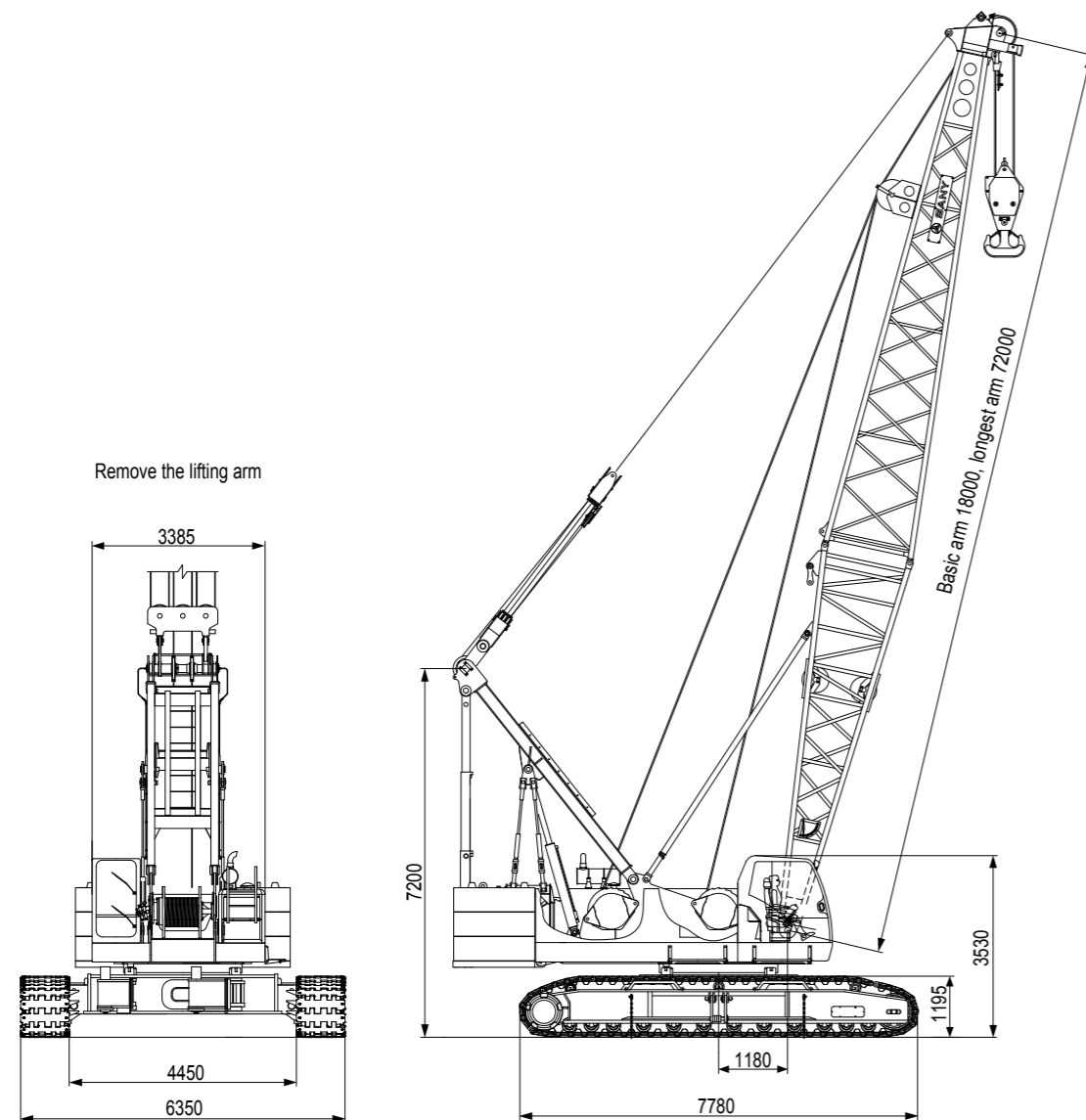

## MAIN TECHNICAL FEATURES

### 1. Safety control system:

Two convenient and reliable modes of operation; working and installation, with real-time level display, stop operation braking away from machine, electrical emergency control, anti-lightning protection, automatically walk switches, CCTV monitoring function, complete safety and supervision system;

### 2. Excellent operating performance:

Advanced load-sensing, limit load regulation and electro-hydraulic proportional micro-speed control make each micro-movement extremely good and operation more stable;

### 3. Reliable function assurance:

Key components adopt famous international brands; sufficient safety margin for structural and mechanical design; control system can operate stably in harsh environments such as cold, high temperature, altitude and sandy conditions;

### 4. Convenient maintenance technology:

It takes approximately no more than 10min/person to adjust;no more than 30min/person for daily maintenance;no more than 2h/person to repair.GPS remote monitoring system is optional for maintenance and management;

### 5. Powerful lifting capacity and operation efficiency:

The rated single line pull is 9.2t, and 16t line pull is optional.The longest boom is 72m;

### 6. Efficient self assembly/disassembly technology:

Self-assembly/disassembly function for standard configuration;

### 7. Big-chassis Design:

Big chassis design ensures excellent stability at 360° working range;

### 8. Reasonable power matching:

With reasonable power matching, the engine features more economical fuel consumption;

### 9. Broad adaptability:

Meet certification requirements of CE, North America, Australia, Russia and Taiwan; the engine emission complies with European and U.S. Non-highway Stage 3 Standards; and also the standard configuration of air pre-filter and fuel pre-filter;

### 10. Many optional configurations:

Optional functions include the third drum, free fall, diesel pre-heating, etc.

## PERFORMANCE DATA

Main performance data of SCC1000C crawler crane			
Performance index		Unit	Data
Boom operating condition	Max. rated lifting capacity	t	100
	Boom length	m	18~72
	Boom luffing angle	°	30~ 80
Operating Condition of Fixed Jib	Max. rated lifting moment	t·m	556.5
	Fully extended boom + fully extended jib	m	60+25/63+19
Working speed	Included angle between boom and jib	°	15、30
	Rope speed of main and auxiliary winch (third tier)	m/min	0~110
	Rope speed of luffing winch (fifth tier)	m/min	0~73
	Swing speed	rpm	0~1.9
	Travel Speed	km/h	1.0/0.68
Engine	Gradeability	%	30
	Output power/rated speed	kW/rpm	183 / 2000
Transportation parameter	Maximum transport weight of single piece	t	43.5
	Transportation size (length x width x height)	mm	9500×3400×3200
Other parameters	Average ground pressure (basic boom)	MPa	0.085

## TRANSPORT DIMENSIONS

<b>Basic Machine</b>	×1
Length	16m
Width	3.4m
Height	3.2m
Weight	46t
<b>Basic Machine</b>	×1
Length	9.5m
Width	3.4m
Height	3.2m
Weight	43.5t
<b>Crawler Track</b>	×2
Length	7.8m
Width	0.95m
Height	1.2m
Weight	16.5t
<b>Boom Tip</b>	×1
Length	10.95m
Width	1.81m
Height	2.24m
Weight	2.06t
<b>Boom Base</b>	×1
Length	7.73m
Width	1.81m
Height	2.03m
Weight	2.79t
<b>3m Boom Insert</b>	×2
Length	3.14m
Width	1.81m
Height	1.83m
Weight	0.6t
<b>6m Boom Insert</b>	×2
Length	6.14m
Width	1.81m
Height	1.83m
Weight	0.95t

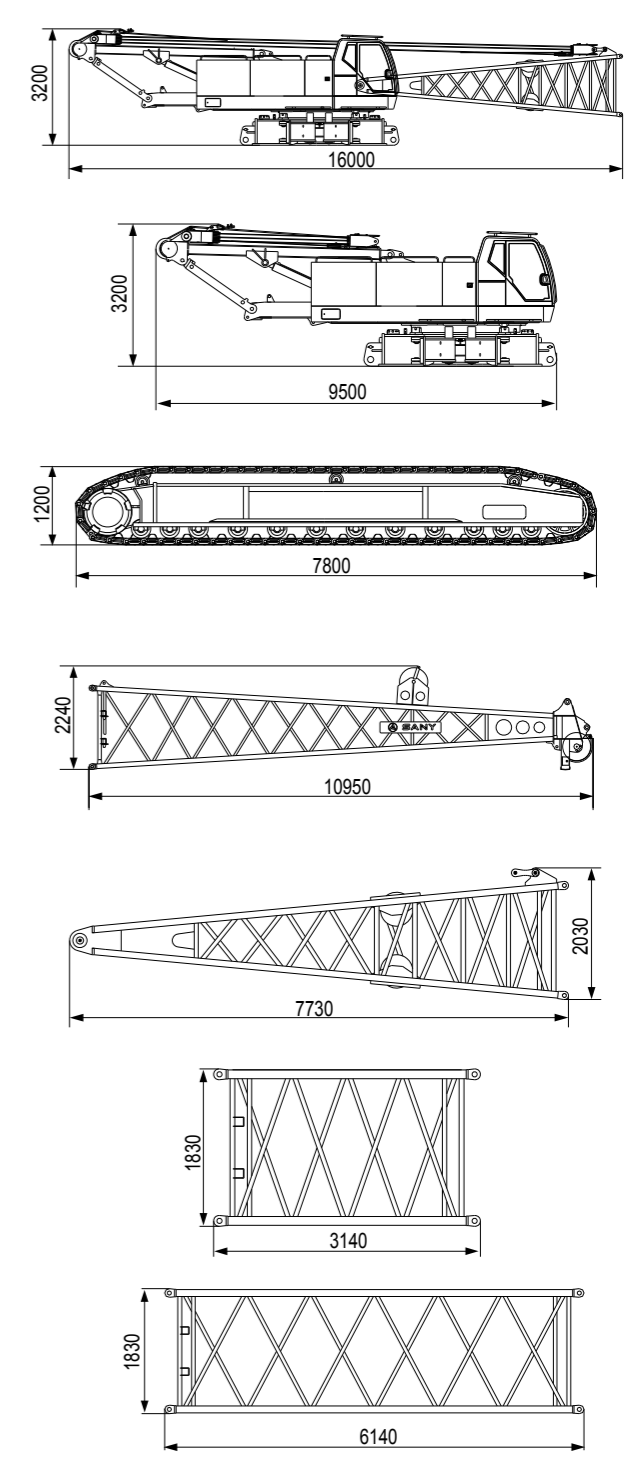

## TRANSPORT DIMENSIONS

<b>9mA Boom Insert</b>	×3
Length	9.14m
Width	1.81m
Height	1.83m
Weight	1.3t
<b>9mB Boom Insert</b>	×1
Length	9.14m
Width	1.81m
Height	1.98m
Weight	1.5t
<b>Jib Tip</b>	×1
Length	5.36m
Width	1.01m
Height	1.17m
Weight	0.3t
<b>Jib Base</b>	×1
Length	5.11m
Width	1.03m
Height	0.83m
Weight	0.3t
<b>3m Jib Insert</b>	×1
Length	3.08m
Width	1.01m
Height	0.83m
Weight	0.14t
<b>6m Jib Insert</b>	×2
Length	6.08m
Width	1.01m
Height	0.83m
Weight	0.3t
<b>Boom Extension</b>	×1
Length	2.15m
Width	1.39m
Height	1.12m
Weight	0.36t

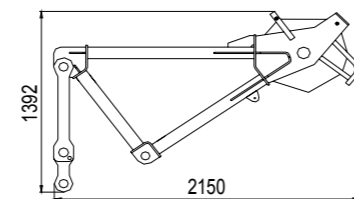
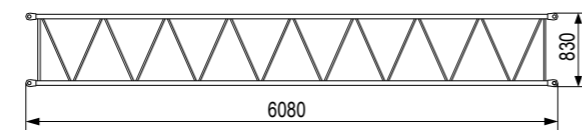
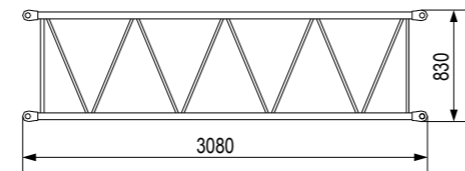
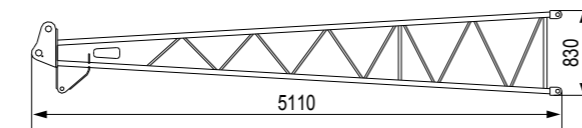
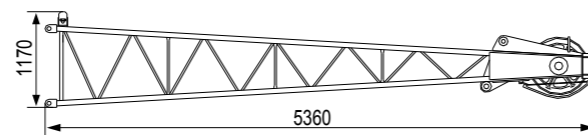
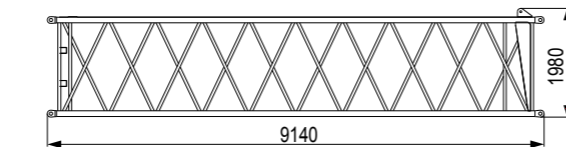
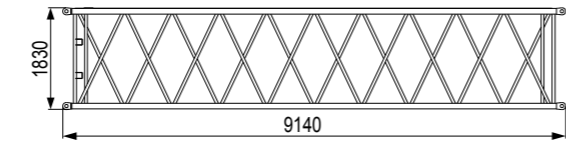

## TRANSPORT DIMENSIONS

<b>Counterweight Tray</b>	×1
Length	5.00m
Width	2.12m
Height	0.49m
Weight	8.9t
<b>Counterweight Block</b>	×6
Length	1.90m
Width	1.59m
Height	0.69m
Weight	5.5t
<b>Additional Counterweight Block</b>	×1
Length	0.93m
Width	0.85m
Height	1.3m
Weight	3t
<b>100t Hook block</b>	×1
Length	2.3m
Width	0.89m
Height	0.84m
Weight	2.54t
<b>50t Hook block</b>	×1
Length	1.99m
Width	0.85m
Height	0.42m
Weight	0.97t

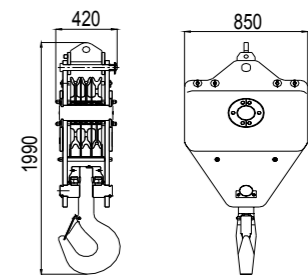
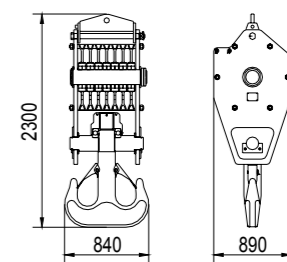
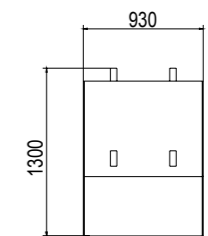
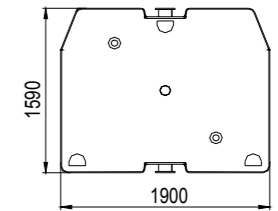
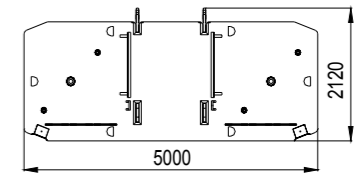

## TRANSPORT DIMENSIONS

<b>25t Hook block</b>	×1
Length	1.82m
Width	0.89m
Height	0.36m
Weight	0.55t
<b>9t Hook block</b>	×1
Length	0.94m
Width	0.36m
Height	0.36m
Weight	0.35t

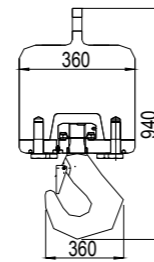
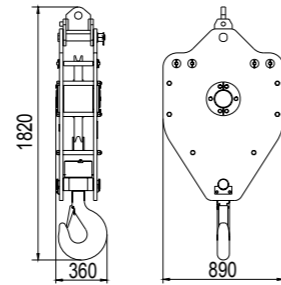

Notes: 1.The transport dimensions of the parts are marked on schematic diagrams, but not drawn by scale; the dimensions indicated are the design values excluding package.  
2.The weight is the design value and there may be tiny difference due to the manufacturing calibration.

## ASSEMBLY DIAGRAM

The crane is equipped with functions of self-assembly/disassembly of crawler traveling tracks and counterweight. In the process of assembly, the crawler traveling tracks shall be first assembled and then the

counterweight. In the process of disassembly, the counterweight shall be disassembled first then the crawler traveling tracks. See the figure below for detailed operation procedures:

### 1) Self assembly and disassembly of crawler frame and counterweight (as for disassembly, reverse the procedure)

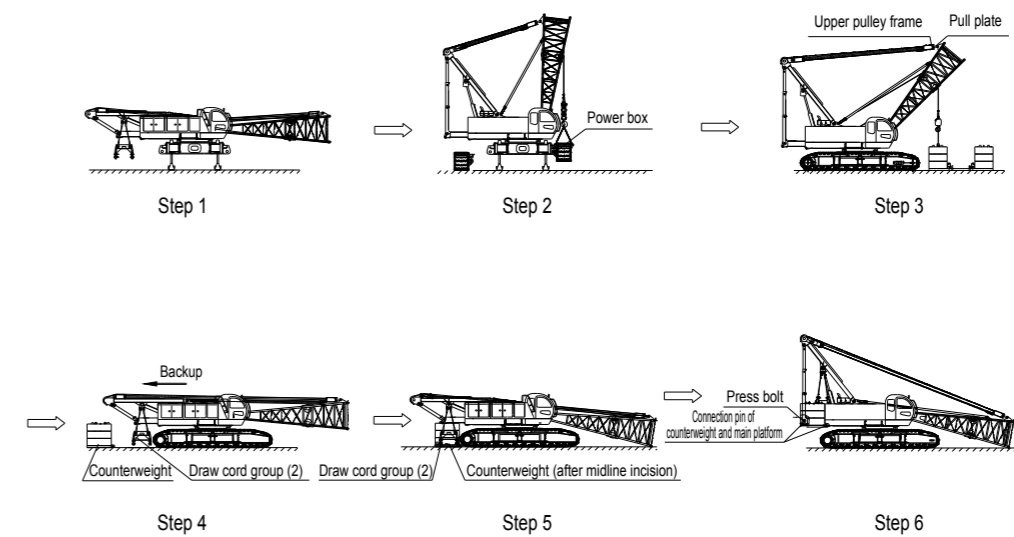

### 2) Assembly the fixed jib

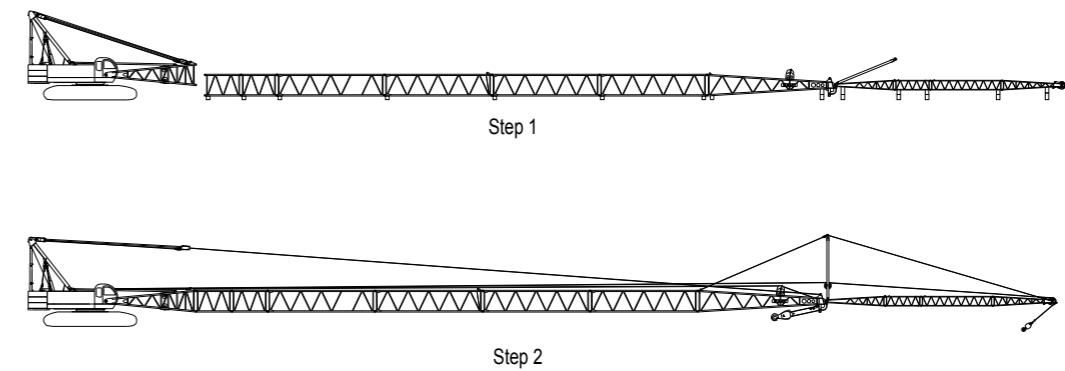

# SCC1000C

UPPERWORKS	13
Lowerworks	15
Operation Device	16
Safety Devices	17

## UPPERWORKS

### 1) Engine

- Imported Cummins QSC8.3.
- Rated power/speed: 183kW/2000rpm.
- Emission standard: Tier 3.
- Air filtering: Two-stage filtering system consisting of air pre-filter and air filter.

Optional engine:

- Type: 6CTAA-250 imported Cummins engine.
- Rated power/rated speed: 186KW/2200rpm.
- Emission standard: Tier 2.

### 2) Electrical Control System

- Controller, combination instrument, engine, load moment indicator, remote control terminal apply CAN bus techniques for data communication.
- Combined instrument can display parameters such as engine rotating speed, fuel quantity, machine oil pressure, servo pressure, wind speed, the engine operating working hours and primary winch lock, main-to-luffing winch lock, turn lock and other working conditions.

### 3) Hydraulic System

- Configuration of hydraulic system: adopt the world-renowned brands of hydraulic systems, including the main pump, main valve, control handle and motor reducer. It is efficient, energy saving, stable and reliable.
- It has excellent micro-rotation and performance improvement, load sensing; limit load regulation makes the operation more stable.
- Adopt controlled hydraulic oil cooling system independently.

### 4) Main and Auxiliary Hoisting Mechanisms

- Main and auxiliary lifting mechanism are independently driven; winding drum is driven directly by winding motor; the drum handle can rotate towards both directions i.e. hoisting and lowering.
- Global brands motor reducer with higher reliability;
- Main drum free fall is optional.
- The fold line winding drum design can ensure that multi-layer winding rope without mess.
- Adopt the steel wire of global well-known brands, which are more reliable and durable.

#### NO.1 Main and Auxiliary Hoisting Mechanisms

Rope speed of the outermost working layer	0~110m/min
Wire rope diameter	φ24mm
Wire rope length of main winch	290m
Wire rope length of auxiliary winch	210m
Rated single rope tension	9.2t

## 5) Luffing Mechanism

- The winch is directly driven by the luffing motor through the reducer. The drum may rotate in two directions through the winch handle, that is, realize the raising and lowering of lifting boom.
- The motor reducer of a world-renowned brand boasts higher reliability.
- The design of polyline drum ensures smooth multi-layer winding of ropes.
- The wire ropes of a world-renowned brand are used, featuring higher reliability and durability.

### NO.2 Luffing Mechanism

Rope speed of the outermost working layer	0~73m/min
Wire rope diameter	φ20mm
Wire rope length of luffing winch	240m
Rated single rope tension	6.9t

## 6) Swing Mechanism

- Inner gear compound swing can rotate 360° .
- Global brands motor reducer with higher reliability.
- Revolution lock: hydraulic control lock adjust pin; upper works can be locked when work is finished or in transport.
- Free wheels pin: In hoisting, boom center and load center are not on the same level due to wrong judgment; free wheels pin can automatically arrange upper works to avoid movement of load after being hoisted.
- Revolution support: Triple-row ball revolution support.
- Slewing speed: 0~1.9rpm.

## 7) Cab

- Newly designed sliding-door cab, large area windows; with near and far beam headlamp, rear-view mirrors and more open vision; Installed with heating and cool air conditioning, MP3 player; seats, control handle; control button layout designed according to ergonomic; thus operation is more comfortable.
- Installed with the manipulation handle, all electrical switches and ignition lock on left, right arm and vice control box. Armrest can be adjusted with the seat.
- Suspension, multi-way adjustable seats with unloading switch.
- Heating and cooling air, optimized air duct and air outlet.

## 8) Counterweight

- Use the mode of overlapped tray and counterweights block for the convenience of mixing, disassembly and transport.
- Counterweight: 42t in total, including: counterweight tray 9t×1, counterweight block 5.5t×6. Additional counterweight: 3t×1.
- Composition: tray 9t×1, and counterweight block 5.5t x 6.
- Additional counterweight: 3t×1.
- Under a special condition, additional counterweight block may improve the lifting capacity of medium and long arms.

# LOWERWORKS

The track frame on both sides adopts separate walk-driven devices. Walking motor can achieve lineal walk and turn of the whole machine through motor reducer and driving wheel.

## 1) Track tensioning

Use pushing guide wheels of hydraulic jacks; adjust the tension of track by adjusting shims.

## 2) Crawler shoes

High-strength alloy steel track link with longer life.



## OPERATION DEVICE

### 1) Boom

- Truss structures; the main chord adopts high strength structure steel; each section is connected with pins.
- Basic boom: 10.5m tip + 7.5m butt.
- Insert: 3m×2, 6m×2, 9mA×3, and 9mB×1.
- Boom length: 18m~72m.

### 2) Jib

- In a truss structure, the main chords use high-strength structure steel pipes. All boom sections are connected with pin shafts.
- Basic arm: 5m tip + 5m base + 3m arm.
- Insert: 6m×2.
- Jib length: 13m~25m.
- Fully extended boom + jib: 60m boom + 25 jib or 63m boom + 19m jib.

### 3) Lifting Hook

- 100t hook block
- 50t hook block
- 25t hook block
- 9t hook block

Notes: The above operating devices are safe configuration; order contract shall prevail for specific configuration.

## SAFETY DEVICES

### 1) Switch between installation/operation mode

In installation mode, anti roll device, lifting boom inhibiting device, load moment indicator do not work to facilitate crane installation. In operation mode, all the safety limit devices are working.

### 2) Emergency stop function

In emergency, press the emergency stop button fixed inside the driver's cab to cut off power supply of the machine and stop all the operations.

### 3) Emergency Function

When the system crashes, use electrical emergency plug and manipulate the machine to a safe status. Then all the security protection functions are not working.

### 4) Load Moment Indicator (LMI)

A completely separate and secure computer-controlled operating system; LMI can automatically detect the load of cranes and the angle of lifting arm and show its rated load and actual load, working radius and boom angle. Functions: can real-time display rated load, actual load, working radius and boom angle, height and other data at current status of the crane. Automatically detect luffing angle transfinite and load transfinite and other dynamic data, and give real-time alarm and limit movement.

- Components: display, machine, monitor, angle sensors, force sensors etc.
- Function: display the data concerning the current situation of crane, including rated load, actual load, operating radius, angle of lifting arm, and height, etc. Detect dynamic data, such as luffing angle.

### 5) Anti-pulley devices of main and auxillary winch

Composed of limit switch, hammer etc. on jib to prevent excessive promotion of hook block. When the lifting hook raises to a certain height, limit switch will work, the buzzer on the control panel will alarm, meanwhile the failure indicator blinks and automatically stop the lifting operation of hook block.

### 6) Anti over-roll out equipments of main and auxillary hoists

It is composed of movement trigger device and proximity switches installed in roll to prevent wire rope from being over-decentralized. When the wire rope is over-decentralized near the last three hoops, limit switch will work, the system will alarm through buzzer, alarm information will be displayed in instrument cluster and automatically stop the decentralization movement of hoist.

### 7) Function Lock

- If the function lock handle is not in place, all the other functions for operating handle will fail to avoid mis-operation caused by collisions in upper and lower works.
- When operator is not seated, all the manipulation will not work; some mis-operations can effectively be avoided.

**8) Winch Lock Device**

The main and auxiliary winches and luffing winch are all equipped with electric-controlled locking devices. Before operating the winch, an operation needs to turn the switch to the release position then act, so as to avoid misoperation of handle and ensure the safety of winch when the crane stops in off-working state.

**9) Rotary locking device**

Hydraulic power pin lock can lock the crane in front, rear, left and right positions. Rotary pin and rotary motion adopt electronically controlled linkage to prevent malfunction.

**10) A-frame Alarm Device**

In assembly mode, If A-frame is not lifted to the given position, it will be shifted to the working mode; the system will give alarms through the buzzer and display, and all actions are not functioning at the same time.

**11) Boom inhibiting device**

- When the elevation angle of lifting arm is greater than 80°, the buzzer will alarm, and boom elevation control will be closed. This protection is controlled by load moment limiter and position switch.
- When the elevation angle of lifting arm is less than 30°, the buzzer will alarm through buzzer and display alarm information in instrument cluster and automatically stop arm sinking operation. This protection is controlled by load moment indicator.

**12) Boom Back-stop Device**

Composed of nesting tube and spring etc. Buffer the energy of boom backwards tilting by spring force to prevent boom backwards tilting.

**13) Signs for boom angle**

Pendulum angle indicating device is fixed in base next to the cab for the convenience of operator.

**14) Hook Clamp**

Lifting hooks are provided with baffle to prevent the rope from dropping.

**15) Monitoring System**

- Cameras: 2 cameras are equipped for monitoring auxiliary winch, luffing winch and the back of whole machine.
- Optional monitoring: variable zoom monitoring system monitors the working conditions of hooks.
- Optional remote control: GPS satellite positioning and GPRS data transfer, device status information, statistics, monitoring and analysis of operational data and remote fault diagnosis can be realized.

**16) Lightning protection device**

Including lightning protection grounding devices and surge protection devices; it can effectively prevent damage to electrical components and operators under lightning strikes.

**17) Level gauge**

Electronic level gauge can display tilt angle of upper works on monitor.

**18) Three-color load warning light**

There is green, yellow and red load warning lights, simultaneous displaying real-time load.

When the actual load is less than 92% of rated load, the "green" light is on; when the actual load is between 92% and 100% of the rated load, the "yellow" light is on, the pre-warning lights will flash and intermittent alarm will be issued; When the actual load reaches 100% of rated load, the "red" light is on, the pre-warning lights will flash and intermittent alarm will be issued; When the actual load reaches 102% of rated load, the system will automatically cut off the trend of crane operation towards danger.

**19) Sound and light alarm device**

When engine is working, lights will flash; in walking or turning, sound alarm will be issued.

**20) Swing indicating device**

When walking or turning, Swing indicating light is blinking.

**21) Lighting**

Equipped with winch lights, lower beam in front of driver, front adjustable high beam, the lighting lamps in driver's cab, lighting equipment for night; these can improve the visibility in construction.

**22) Rearview mirror**

Set respectively on the right of the driver's cab and armrest in front of hood for the convenience of monitoring the rear status of the machine.

**23) Navigation light**

Installed on the top of boom; provide instructions for boom at height.

**24) Seat-leaving Protection**

When the operator is not at seat, all manipulations will be out of function, so as to avoid some misoperations effectively.

**25) Anemometer**

Installed at the top of boom supporter for real-time monitoring of wind speed; and transmit the data to driver's cab and display on monitor.

# SCC1000C

Operating Condition Combination	21
H Operating Condition of Boom	22
FJ Operating Condition of Fixed Jib	27

## OPERATING CONDITION COMBINATION

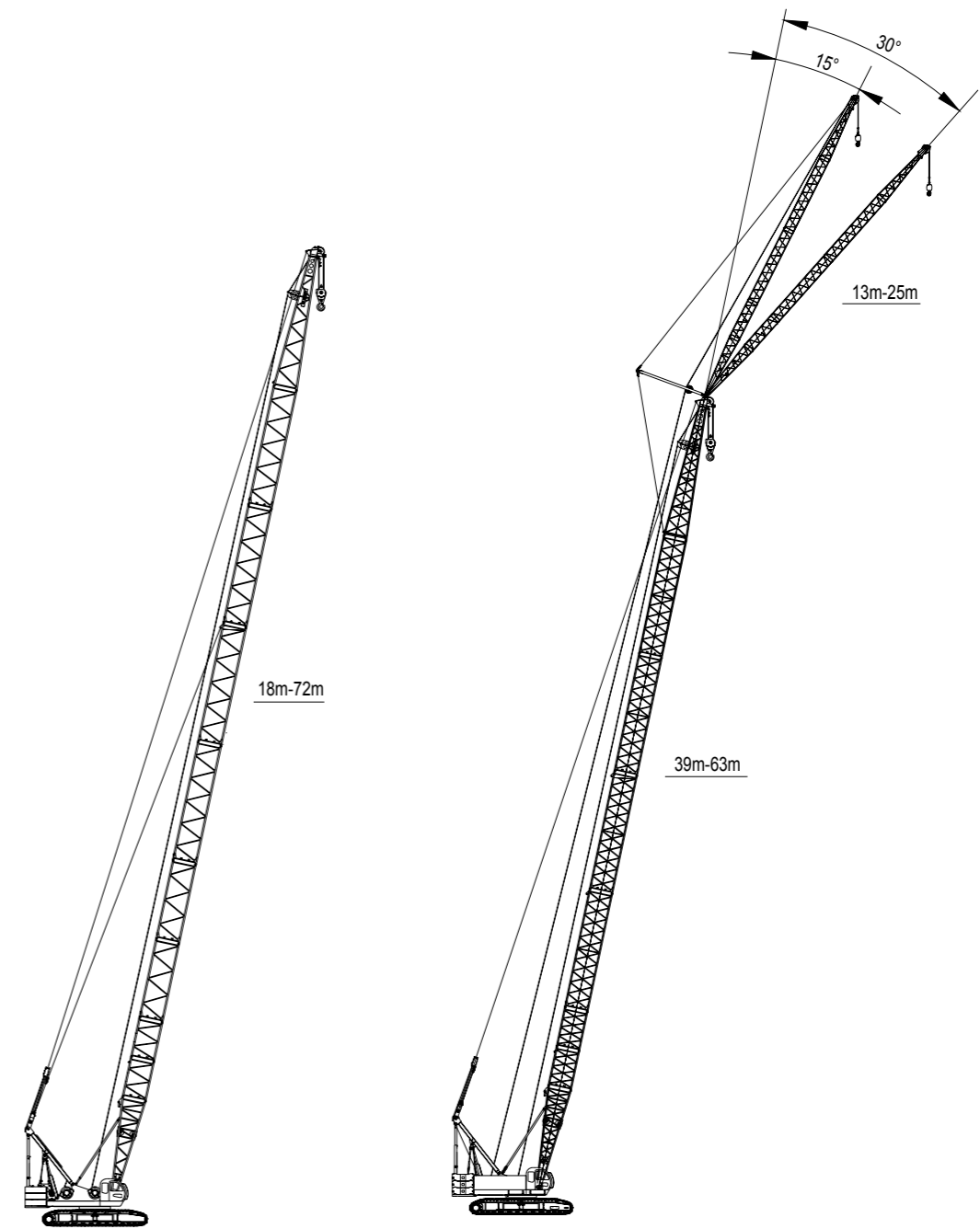

H operation condition  
Boom: 18m~72m

FJ operating condition  
Boom: 39m~63m  
Fixed jib: 13m~25m

# H OPERATION CONDITION

Boom length m	Insert			
	3 m	6 m	9mA	9mB
18	-	-	-	-
21	1	-	-	-
24	-	1	-	-
	2	-	-	-
27	1	1	-	-
	-	-	1	-
30	1	-	1	-
	-	2	-	-
33	1	2	-	-
	-	1	1	-
36	1	1	1	-
	-	-	2	-
	2	2	-	-
39	2	1	1	-
	1	-	2	-
	-	2	1	-
42	2	-	2	-
	-	1	2	-
	1	1	2	-
45	-	-	3	-
	2	2	1	-
	1	-	3	-
48	2	1	2	-
	-	2	2	-
	-	1	3	-
51	2	-	3	-
	2	2	2	-
54	1	1	3	-
	2	1	3	-
57	-	2	3	-
	1	2	2	1
60	2	-	3	1
	2	2	2	1
63	2	2	2	1
66	2	1	3	1
69	1	2	3	1
72	2	2	3	1

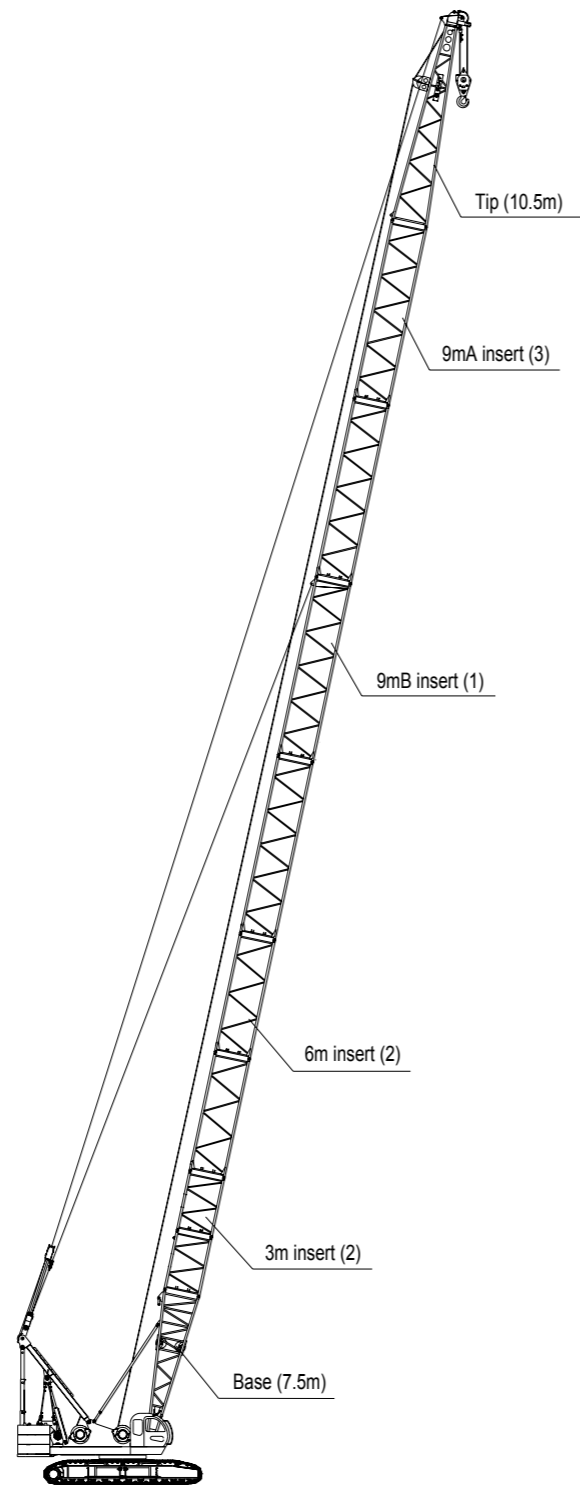

# H OPERATION CONDITION RANGE DIAGRAM

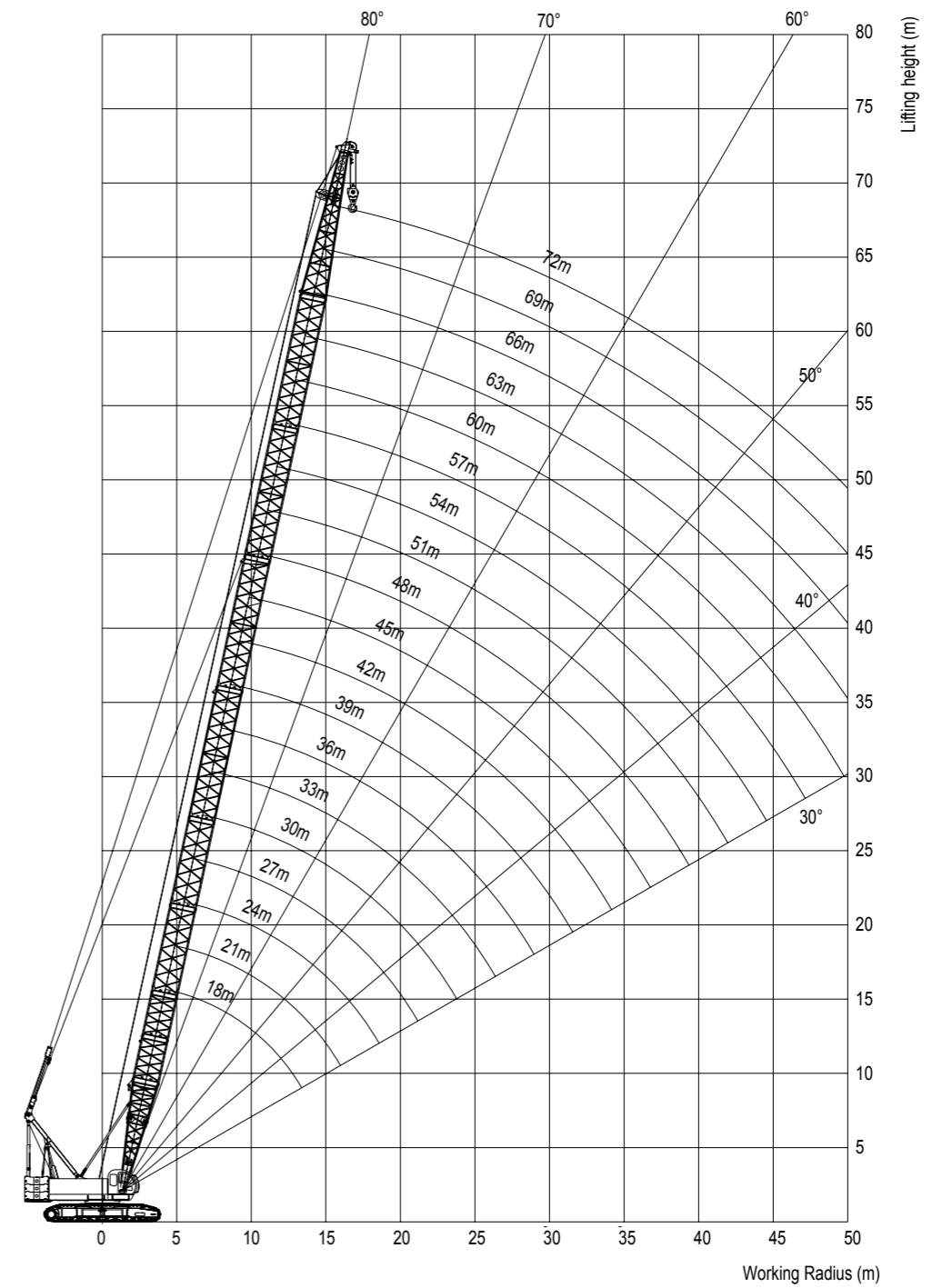

# H OPERATION CONDITION LOAD CHARTS

## SCC 1000C Crawler Crane H operation condition load charts

Unit: (t)

Radius(m)	Boom(m)	18	21	24	27	30	33	36
5.5		100.0	5.6/90.9					
6		92.5	90.0	6.1/80.8	6.6/70.8			
7		79.5	78.7	77.5	70.0	7.2/60.5	7.7/57.3	
8		66.0	65.7	65.5	64.6	60.0	56.6	8.2/50.5
9		55.2	55.1	54.9	54.8	54.7	54.2	50.0
10		47.5	47.3	47.2	47.1	46.9	46.8	46.6
12		36.9	36.7	36.5	36.4	36.3	36.1	36.0
14		30.1	29.8	29.6	29.5	29.3	30.2	29.1
16		25.2	25.0	24.8	24.7	24.5	24.3	24.2
18		17.5/21.7	21.5	21.2	21.1	20.9	20.8	20.7
20			19.4	18.6	18.4	18.2	18.0	17.9
22			21.1/17.1	17.0	16.3	16.1	15.9	15.8
24				22.7/14.7	14.5	14.2	14.1	14.0
26					25.4/12.8	12.7	12.6	12.5
28						28.0/11.1	11.4	11.3
30							10.5	10.3
32							30.7/9.7	9.4
34								33.3/8.6
Counterweight		42	42	42	42	42	42	42
Multiplying Factor		14	12	10	8	7	7	7
Radius(m)	Boom(m)	39	42	45	48			
8		8.7/46.6	8.7/49.4					
9		46.2	49.0	9.3/44.2	9.3/46.9	9.8/41.2	9.8/43.7	
10		44.7	47.4	42.4	44.9	40.4	42.8	10.3/35.6
12		35.9	38.1	35.8	37.9	35.7	37.8	33.7
14		28.9	30.6	28.8	30.5	28.7	30.4	28.6
16		24.0	25.4	23.9	25.3	23.8	25.2	23.7
18		20.5	21.7	20.4	21.6	20.2	21.4	20.1
20		17.7	18.8	17.6	18.7	17.5	18.6	17.4
22		15.6	16.5	15.5	16.4	15.3	16.2	15.2
24		13.7	14.5	13.6	14.4	13.5	14.3	13.3
26		12.3	13.0	12.2	12.9	12.0	12.7	11.9
28		11.0	11.7	10.9	11.6	10.8	11.4	10.6
30		10.0	10.6	9.9	10.5	9.7	10.3	9.6
32		9.1	9.6	9.0	9.5	8.8	9.3	8.7
34		8.4	8.9	8.2	8.7	8.1	8.6	7.9
36		35.9/7.4	35.9/7.8	7.3	7.7	7.2	7.6	7.1
38				6.8	7.2	6.7	7.1	6.5
40				38.6/6.5	38.6/6.9	6.2	6.6	6.1
42						41.2/5.6	41.2/5.9	5.5
44							43.9/4.7	43.9/5.0
Counterweight		42	42+3	42	42+3	42	42+3	42
Multiplying Factor		6		5		5		5

- Notes: 1.The actual lifting capacity is the rated lifting capacity indicated in the table minus the weights of all hoisting tools;  
 2.The rated lifting capacity in the figure is the weight hoisted on a level and hard ground;  
 3.The 40% orange and italic parts in the table indicate the rated loads with additional counterweight, the values of 25% orange and italic parts depend on boom strength ;  
 4.In order to prevent tip-over backward, the boom of over 39m long must first be connected and then additional counterweight may be mounted; any boom less than 39m long cannot use additional counterweight.

# H OPERATION CONDITION LOAD CHARTS

## SCC 1000C Crawler Crane H operation condition load charts

unit: (t)

Radius(m)	Boom(m)	51	54	57	60			
10		10.9/32.8	10.9/34.8	11.4/28.7	11.4/30.4	11.9/26.3	11.9/27.9	
12		30.3	32.1	28.2	29.9	26.2	27.8	12.4/24.5
14		28.5	30.2	26.9	28.5	25.3	26.8	23.7
16		23.5	24.9	23.4	24.8	23.2	24.6	22.1
18		20.0	21.2	19.8	21.0	19.6	20.8	19.5
20		17.2	18.2	17.1	18.1	16.9	17.9	16.8
22		14.9	15.8	14.8	15.7	14.6	15.5	14.5
24		13.2	14.0	13.0	13.8	12.8	13.6	12.7
26		11.7	12.4	11.5	12.2	11.3	12.0	11.2
28		10.5	11.1	10.3	10.9	10.1	10.7	10.0
30		9.4	10.0	9.3	9.9	9.0	9.5	8.9
32		8.5	9.0	8.4	8.9	8.1	8.6	8.0
34		7.7	8.2	7.6	8.1	7.3	7.7	7.2
36		7.0	7.4	6.9	7.3	6.6	7.0	6.5
38		6.4	6.8	6.3	6.7	6.0	6.4	6.0
40		5.9	6.3	5.7	6.0	5.5	5.8	5.4
42		5.4	5.7	5.2	5.5	4.9	5.2	4.8
44		4.6	4.9	4.5	4.8	4.4	4.7	4.3
46		4.4	4.7	4.3	4.6	4.0	4.2	3.8
48		46.5/3.9	46.5/4.1	3.6	3.8	3.5	3.7	3.4
50				49.1/3.3	49.1/3.5	3.1	3.3	3.0
52						51.8/2.7	51.8/2.9	2.6
Counterweight		42	42+3	42	42+3	42	42+3	42
Multiplying Factor		4		4		4		3
Radius(m)	Boom(m)	63	66	69	72			
12		13.0/22.9	13.0/24.3	13.5/19.4	13.5/20.6			
14		21.8	23.1	19.2	20.4	14.1/17.8	14.1/18.9	14.6/16.0
16		20.2	21.4	18.3	19.4	17.0	18.0	15.4
18		19.4	20.6	17.5	18.6	16.2	17.2	14.6
20		16.7	17.7	16.5	17.5	15.5	16.4	13.9
22		14.4	15.3	14.2	15.1	14.0	14.8	13.0
24		12.6	13.4	12.4	13.1	12.2	12.9	12.0
26		11.1	11.8	10.9	11.6	10.7	11.3	10.5
28		9.9	10.5	9.7	10.3	9.5	10.1	9.3
30		8.8	9.3	8.6	9.1	8.4	8.9	8.2
32		7.9	8.4	7.7	8.2	7.5	8.0	7.3
34		7.1	7.5	6.9	7.3	6.7	7.1	6.5
36		6.4	6.8	6.2	6.6	6.0	6.4	5.8
38		5.8	6.1	5.6	5.9	5.4	5.7	5.1
40		5.2	5.5	4.9	5.2	4.6	4.9	4.3
42		4.6	4.9	4.3	4.6	4.1	4.3	3.8
44		4.1	4.3	3.8	4.0	3.5	3.7	3.2
46		3.6	3.8	3.3	3.5	3.1	3.3	2.8
48		3.2	3.4	2.9	3.1	2.6	2.8	2.3
50		2.8	3.0	2.5	2.7	2.3	2.4	2.0
52		2.4	2.5	2.1	2.2	2.0	2.1	1.8
Counterweight		42	42+3	42	42+3	42	42+3	42
Multiplying Factor		3		3		3		3

- Notes: 1.The actual lifting capacity is the rated lifting capacity indicated in the table minus the weights of all hoisting tools;  
 2.The rated lifting capacity in the figure is the weight hoisted on a level and hard ground;  
 3.The 40% orange and italic parts in the table indicate the rated loads with additional counterweight, the values of 25% orange and italic parts depend on the strength;  
 4.In order to prevent tip-over backward, the boom of over 39m long must first be connected and then additional counterweight may be mounted; any boom less than 39m long cannot use additional counterweight.

# H OPERATION CONDITION LOAD CHARTS

## Note — Rated load of crane

- 1.The rated load indicated in the table is the value computed by taking 75% of the tipover load.
- 2.All values in the load chart are suitable for 360° slewing.
- 3.When additional counterweight (42t+3t) is used, it is an optional operating condition, rather than a standard operating condition. The boom allowing using additional counterweight is 39m~72m.

# FIXED JIB OPERATION CONDITION

Length of jib (m)	Insert		Length of boom (m)	Included angle between boom and jib
	3 m	6 m		
13	1	-	39~63	15°, 30°
19	1	1	39~63	15°, 30°
25	1	2	39~60	15°, 30°

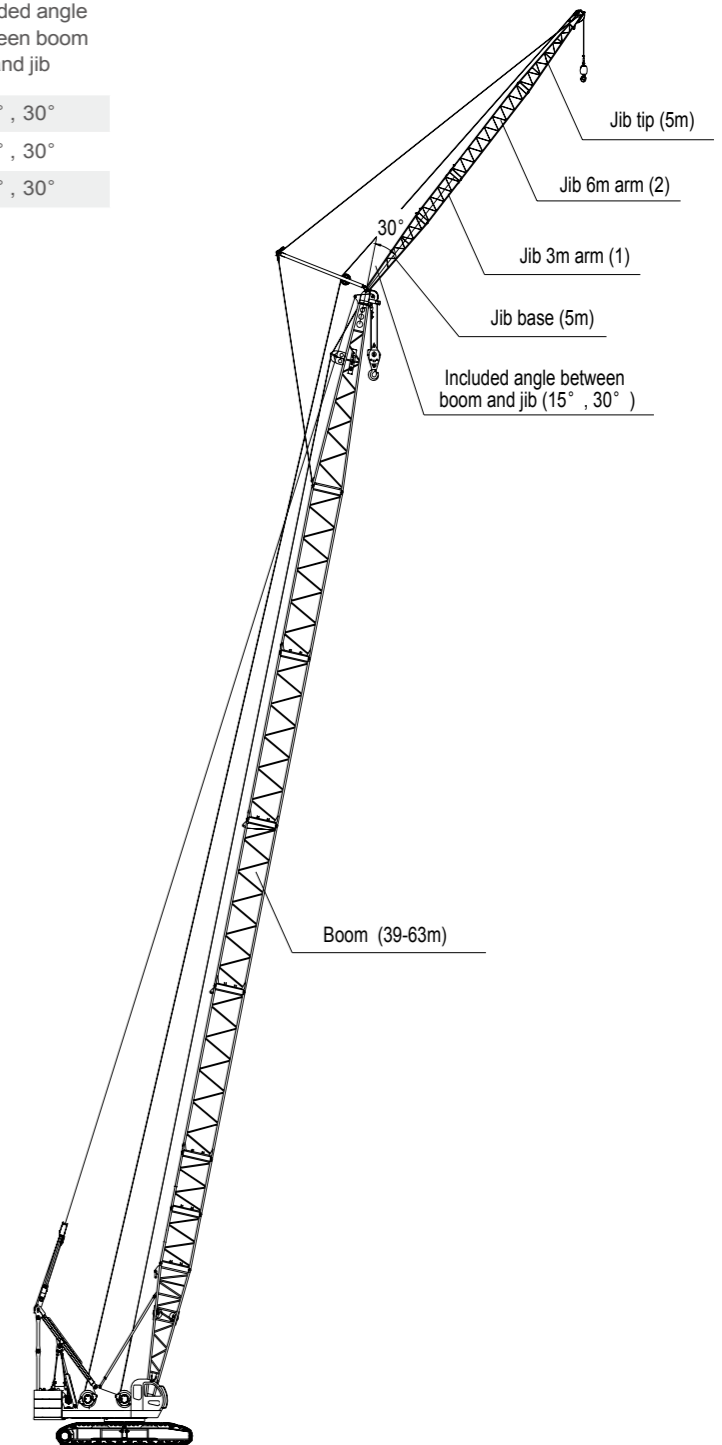

# FIXED JIB RANGE DIAGRAM

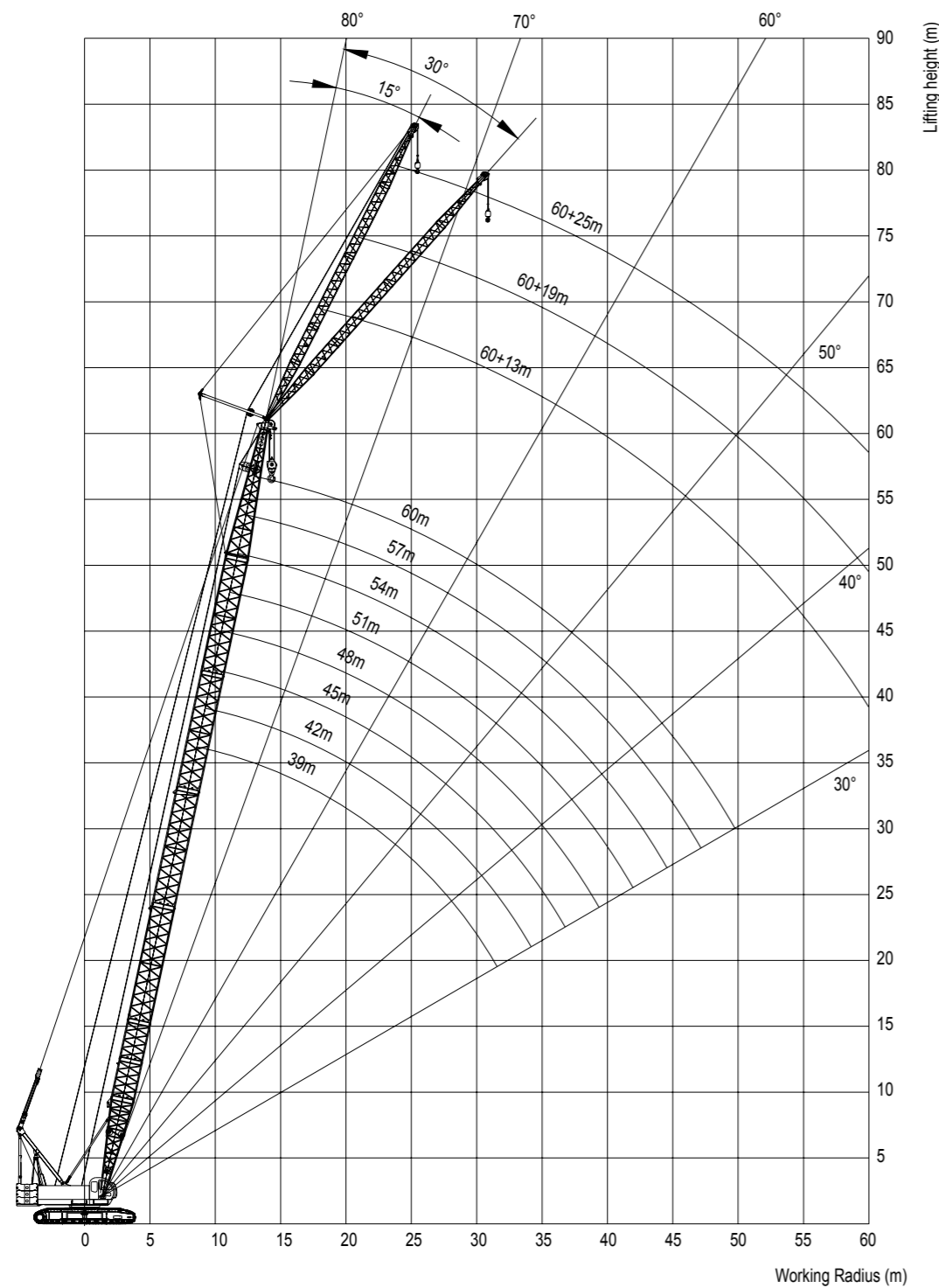

# FIXED JIB LOAD CHARTS

SCC 1000C Crawler Crane  
Fixed jib load charts

unit: (t)

Boom(m)	39m											
Jib (m)	13m			19m			25m					
Jib Angle	15°		30°		15°		30°		15°		30°	
Radius (m)												
14	14.3/11.0	<i>14.3/11.5</i>										
16	11.0	<i>11.5</i>	17.2/8.0	<i>17.2/8.4</i>	17.2/7.2	<i>17.2/7.5</i>						
18	11.0	<i>11.5</i>	8.0	<i>8.4</i>	7.2	<i>7.5</i>			19.5/4.6	<i>19.5/4.8</i>		
20	11.0	<i>11.5</i>	8.0	<i>8.4</i>	7.2	<i>7.5</i>	21.1/5.7	<i>21.1/6.0</i>	4.6	<i>4.8</i>		
22	11.0	<i>11.5</i>	8.0	<i>8.4</i>	7.2	<i>7.5</i>	5.7	<i>6.0</i>	4.6	<i>4.8</i>		
24	11.0	<i>11.5</i>	8.0	<i>8.4</i>	7.2	<i>7.5</i>	5.7	<i>6.0</i>	4.6	<i>4.8</i>	25.1/3.9	<i>25.1/4.1</i>
26	11.0	<i>11.5</i>	8.0	<i>8.4</i>	7.2	<i>7.5</i>	5.7	<i>6.0</i>	4.6	<i>4.8</i>	3.9	<i>4.1</i>
28	29.0/11.0	<i>29.0/11.5</i>	8.0	<i>8.4</i>	7.2	<i>7.5</i>	5.7	<i>6.0</i>	4.6	<i>4.8</i>	3.9	<i>4.1</i>
30	10.6	<i>11.1</i>	8.0	<i>8.4</i>	7.2	<i>7.5</i>	5.7	<i>6.0</i>	4.6	<i>4.8</i>	3.9	<i>4.1</i>
32	10.0	<i>10.5</i>	8.0	<i>8.4</i>	7.2	<i>7.5</i>	5.7	<i>6.0</i>	4.6	<i>4.8</i>	3.9	<i>4.1</i>
34	9.4	<i>9.8</i>	8.0	<i>8.4</i>	7.2	<i>7.5</i>	5.7	<i>6.0</i>	4.6	<i>4.8</i>	3.9	<i>4.1</i>
36	34.7/9.4	<i>34.7/9.8</i>	34.7/8.0	<i>34.7/8.4</i>	34.7/7.2	<i>34.7/7.5</i>	34.7/5.7	<i>34.7/6.0</i>	34.7/4.6	<i>34.7/4.8</i>	34.7/3.9	<i>34.7/4.1</i>
Counterweight	42	42+3	42	42+3	42	42+3	42	42+3	42	42+3	42	42+3

Boom(m)	42m											
Jib (m)	13m			19m			25m					
Jib Angle	15°		30°		15°		30°		15°		30°	
Radius (m)												
14	14.9/11.0	<i>14.9/11.5</i>										
16	11.0	<i>11.5</i>			17.6/7.2	<i>17.6/7.5</i>						
18	11.0	<i>11.5</i>	18.2/8.0	<i>18.2/8.4</i>	7.2	<i>7.5</i>						
20	11.0	<i>11.5</i>	8.0	<i>8.4</i>	7.2	<i>7.5</i>	21.5/5.7	<i>21.5/6.0</i>	20.1/4.6	<i>20.1/4.8</i>		
22	11.0	<i>11.5</i>	8.0	<i>8.4</i>	7.2	<i>7.5</i>	5.7	<i>6.0</i>	4.6	<i>4.8</i>		
24	11.0	<i>11.5</i>	8.0	<i>8.4</i>	7.2	<i>7.5</i>	5.7	<i>6.0</i>	4.6	<i>4.8</i>	25.4/3.9	<i>25.4/4.1</i>
26	11.0	<i>11.5</i>	8.0	<i>8.4</i>	7.2	<i>7.5</i>	5.7	<i>6.0</i>	4.6	<i>4.8</i>	3.9	<i>4.1</i>
28	11.0	<i>11.5</i>	8.0	<i>8.4</i>	7.2	<i>7.5</i>	5.7	<i>6.0</i>	4.6	<i>4.8</i>	3.9	<i>4.1</i>
30	11.0	<i>11.5</i>	8.0	<i>8.4</i>	7.2	<i>7.5</i>	5.7	<i>6.0</i>	4.6	<i>4.8</i>	3.9	<i>4.1</i>
32	10.3	<i>10.8</i>	8.0	<i>8.4</i>	7.2	<i>7.5</i>	5.7	<i>6.0</i>	4.6	<i>4.8</i>	3.9	<i>4.1</i>
34	9.3	<i>9.7</i>	8.0	<i>8.4</i>	7.2	<i>7.5</i>	5.7	<i>6.0</i>	4.6	<i>4.8</i>	3.9	<i>4.1</i>
36	8.4	<i>8.8</i>	8.0	<i>8.4</i>	7.2	<i>7.5</i>	5.7	<i>6.0</i>	4.6	<i>4.8</i>	3.9	<i>4.1</i>
38	37.1/8.2	<i>37.1/8.6</i>	37.1/8.0	<i>37.1/8.4</i>	37.1/7.2	<i>37.1/7.5</i>	37.1/5.7	<i>37.1/6.0</i>	37.1/4.6	<i>37.1/4.8</i>	37.1/3.9	<i>37.1/4.1</i>
Counterweight	42	42+3	42	42+3	42	42+3	42	42+3	42	42+3	42	42+3

- Notes: 1.The actual lifting capacity is the rated lifting capacity indicated in the table minus the weights of all hoisting tools;  
 2.The rated lifting capacity in the figure is the weight hoisted on a level and hard ground;  
 3.The 40% orange and italic parts in the table indicate the rated loads with additional counterweight, the values of 25% orange and italic parts depend on the strength;  
 4.In order to prevent tip-over backward, the boom of over 39m long must first be connected and then additional counterweight may be mounted; any boom less than 39m long cannot use additional counterweight.

# FIXED JIB LOAD CHARTS

## SCC 1000C Crawler Crane Fixed jib load charts

unit: (t)

Boom(m)		45m											
Jib (m)	13m				19m				25m				
Jib Angle	15°		30°		15°		30°		15°		30°		
Radius (m)													
14	15.1/11.0	<i>15.1/11.5</i>											
16	11.0	<i>11.5</i>											
18	11.0	<i>11.5</i>	18.2/8.0	<i>18.2/8.4</i>	18.1/7.2	<i>18.1/7.5</i>							
20	11.0	<i>11.5</i>	8.0	<i>8.4</i>	7.2	<i>7.5</i>			20.7/4.6	<i>20.7/4.8</i>			
22	11.0	<i>11.5</i>	8.0	<i>8.4</i>	7.2	<i>7.5</i>	22.3/5.7	<i>22.3/6.0</i>	4.6	<i>4.8</i>			
24	11.0	<i>11.5</i>	8.0	<i>8.4</i>	7.2	<i>7.5</i>	5.7	<i>6.0</i>	4.6	<i>4.8</i>	25.9/3.9	<i>25.9/4.1</i>	
26	11.0	<i>11.5</i>	8.0	<i>8.4</i>	7.2	<i>7.5</i>	5.7	<i>6.0</i>	4.6	<i>4.8</i>	3.9	<i>4.1</i>	
28	11.0	<i>11.5</i>	8.0	<i>8.4</i>	7.2	<i>7.5</i>	5.7	<i>6.0</i>	4.6	<i>4.8</i>	3.9	<i>4.1</i>	
30	30.3/11.0	<i>30.3/11.5</i>	8.0	<i>8.4</i>	7.2	<i>7.5</i>	5.7	<i>6.0</i>	4.6	<i>4.8</i>	3.9	<i>4.1</i>	
32	10.2	<i>10.7</i>	8.0	<i>8.4</i>	7.2	<i>7.5</i>	5.7	<i>6.0</i>	4.6	<i>4.8</i>	3.9	<i>4.1</i>	
34	9.2	<i>9.6</i>	8.0	<i>8.4</i>	7.2	<i>7.5</i>	5.7	<i>6.0</i>	4.6	<i>4.8</i>	3.9	<i>4.1</i>	
36	8.4	<i>8.8</i>	36.8/8.0	<i>36.8/8.4</i>	7.2	<i>7.5</i>	5.7	<i>6.0</i>	4.6	<i>4.8</i>	3.9	<i>4.1</i>	
38	8.1	<i>8.5</i>	7.8	<i>8.2</i>	7.2	<i>7.5</i>	5.7	<i>6.0</i>	4.6	<i>4.8</i>	3.9	<i>4.1</i>	
40	7.5	<i>7.8</i>	7.4	<i>7.7</i>	7.2	<i>7.5</i>	5.7	<i>6.0</i>	4.6	<i>4.8</i>	3.9	<i>4.1</i>	
42	40.3/7.4	<i>40.3/7.7</i>	40.3/7.3	<i>40.3/7.6</i>	40.3/7.2	<i>40.3/7.5</i>	40.3/5.7	<i>40.3/6.0</i>	40.3/4.6	<i>40.3/4.8</i>	40.3/3.9	<i>40.3/4.1</i>	
Counterweight	42	42+3	42	42+3	42	42+3	42	42+3	42	42+3	42	42+3	

Boom(m)		48m											
Jib (m)	13m				19m				25m				
Jib Angle	15°		30°		15°		30°		15°		30°		
Radius (m)													
16	15.9/11.0	<i>15.9/11.5</i>											
18	11.0	<i>11.5</i>	18.4/8.0	<i>18.4/8.4</i>	18.2/7.2	<i>18.2/7.5</i>							
20	11.0	<i>11.5</i>	8.0	<i>8.4</i>	7.2	<i>7.5</i>			21.2/4.6	<i>21.2/4.8</i>			
22	11.0	<i>11.5</i>	8.0	<i>8.4</i>	7.2	<i>7.5</i>	22.7/5.7	<i>22.7/6.0</i>	4.6	<i>4.8</i>			
24	11.0	<i>11.5</i>	8.0	<i>8.4</i>	7.2	<i>7.5</i>	5.7	<i>6.0</i>	4.6	<i>4.8</i>			
26	11.0	<i>11.5</i>	8.0	<i>8.4</i>	7.2	<i>7.5</i>	5.7	<i>6.0</i>	4.6	<i>4.8</i>	26.5/3.9	<i>26.5/4.1</i>	
28	11.0	<i>11.5</i>	8.0	<i>8.4</i>	7.2	<i>7.5</i>	5.7	<i>6.0</i>	4.6	<i>4.8</i>	3.9	<i>4.1</i>	
30	30.1/11.0	<i>30.1/11.5</i>	8.0	<i>8.4</i>	7.2	<i>7.5</i>	5.7	<i>6.0</i>	4.6	<i>4.8</i>	3.9	<i>4.1</i>	
32	10.1	<i>10.6</i>	8.0	<i>8.4</i>	7.2	<i>7.5</i>	5.7	<i>6.0</i>	4.6	<i>4.8</i>	3.9	<i>4.1</i>	
34	9.1	<i>9.5</i>	8.0	<i>8.4</i>	7.2	<i>7.5</i>	5.7	<i>6.0</i>	4.6	<i>4.8</i>	3.9	<i>4.1</i>	
36	8.2	<i>8.6</i>	8.0	<i>8.4</i>	7.2	<i>7.5</i>	5.7	<i>6.0</i>	4.6	<i>4.8</i>	3.9	<i>4.1</i>	
38	8.0	<i>8.4</i>	7.4	<i>7.7</i>	7.2	<i>7.5</i>	5.7	<i>6.0</i>	4.6	<i>4.8</i>	3.9	<i>4.1</i>	
40	7.3	<i>7.6</i>	7.3	<i>7.6</i>	7.2	<i>7.5</i>	5.7	<i>6.0</i>	4.6	<i>4.8</i>	3.9	<i>4.1</i>	
42	7.1	<i>7.4</i>	7.1	<i>7.4</i>	7.0	<i>7.3</i>	5.7	<i>6.0</i>	4.6	<i>4.8</i>	3.9	<i>4.1</i>	
44	42.8/6.9	<i>42.8/7.2</i>	42.8/6.8	<i>42.8/7.1</i>	42.8/6.7	<i>42.8/7.0</i>	42.8/5.7	<i>42.8/6.0</i>	42.8/4.6	<i>42.8/4.8</i>	42.8/3.9	<i>42.8/4.1</i>	
Counterweight	42	42+3	42	42+3	42	42+3	42	42+3	42	42+3	42	42+3	

Notes: 1.The actual lifting capacity is the rated lifting capacity indicated in the table minus the weights of all hoisting tools;  
 2.The rated lifting capacity in the figure is the weight hoisted on a level and hard ground;  
 3.The 40% orange and italic parts in the table indicate the rated loads with additional counterweight, the values of 25% orange and italic parts depend on the strength;  
 4.In order to prevent tip-over backward, the boom of over 39m long must first be connected and then additional counterweight may be mounted; any boom less than 39m long cannot use additional counterweight.

# FIXED JIB LOAD CHARTS

## SCC 1000C Crawler Crane Fixed jib load charts

unit: (t)

Boom(m)		51m											
Jib (m)	13m				19m				25m				
Jib Angle	15°		30°		15°		30°		15°		30°		
Radius (m)													
16	16.3/11.0	<i>16.3/11.5</i>											
18	11.0	<i>11.5</i>	19.1/8.0	<i>19.1/8.4</i>	18.7/7.2	<i>18.7/7.5</i>							
20	11.0	<i>11.5</i>	8.0	<i>8.4</i>	7.2	<i>7.5</i>							
22	11.0	<i>11.5</i>	8.0	<i>8.4</i>	7.2	<i>7.5</i>	23.4/5.7	<i>23.4/6.0</i>	21.9/4.6	<i>21.9/4.8</i>	21.5/3.9	<i>21.5/4.1</i>	
24	11.0	<i>11.5</i>	8.0	<i>8.4</i>	7.2	<i>7.5</i>	5.7	<i>6.0</i>	4.6	<i>4.8</i>	3.9	<i>4.1</i>	
26	11.0	<i>11.5</i>	8.0	<i>8.4</i>	7.2	<i>7.5</i>	5.7	<i>6.0</i>	4.6	<i>4.8</i>	3.9	<i>4.1</i>	
28	11.0	<i>11.5</i>	8.0	<i>8.4</i>	7.2	<i>7.5</i>	5.7	<i>6.0</i>	4.6	<i>4.8</i>	3.9	<i>4.1</i>	
30	29.6/11.0	<i>29.6/11.5</i>	8.0	<i>8.4</i>	7.2	<i>7.5</i>	5.7	<i>6.0</i>	4.6	<i>4.8</i>	3.9	<i>4.1</i>	
32	9.9	<i>10.3</i>	8.0	<i>8.4</i>	7.2	<i>7.5</i>	5.7	<i>6.0</i>	4.6	<i>4.8</i>	3.9	<i>4.1</i>	
34	9.0	<i>9.4</i>	8.0	<i>8.4</i>	7.2	<i>7.5</i>	5.7	<i>6.0</i>	4.6	<i>4.8</i>	3.9	<i>4.1</i>	
36	8.1	<i>8.5</i>	36.2/8.0	<i>36.2/8.4</i>	7.2	<i>7.5</i>	5.7	<i>6.0</i>	4.6	<i>4.8</i>	3.9	<i>4.1</i>	
38	8.0	<i>8.4</i>	7.3	<i>7.6</i>	7.2	<i>7.5</i>	5.7	<i>6.0</i>	4.6	<i>4.8</i>	3.9	<i>4.1</i>	
40	7.2	<i>7.5</i>	7.1	<i>7.4</i>	40.9/7.2	<i>40.9/7.5</i>	5.7	<i>6.0</i>	4.6	<i>4.8</i>	3.9	<i>4.1</i>	
42	6.9	<i>7.2</i>	6.9	<i>7.2</i>	6.8	<i>7.1</i>	5.7	<i>6.0</i>	4.6	<i>4.8</i>	3.9	<i>4.1</i>	
44	6.7	<i>7.0</i>	6.7	<i>7.0</i>	6.6	<i>6.9</i>	5.7	<i>6.0</i>	4.6	<i>4.8</i>	3.9	<i>4.1</i>	
46	44.6/6.2	<i>44.6/6.5</i>	44.6/6.2	<i>44.6/6.5</i>	44.6/6.1	<i>44.6/6.4</i>	44.6/5.7	<i>44.6/6.0</i>	44.6/4.6	<i>44.6/4.8</i>	44.6/3.9	<i>44.6/4.1</i>	
Counterweight	42	42+3	42	42+3	42	42+3	42	42+3	42	42+3	42	42+3	

Boom(m)		54m											
Jib (m)	13m				19m				25m				
Jib Angle	15°		30°		15°		30°		15°		30°		
Radius (m)													
16	17.1/11.0	<i>17.1/11.5</i>											
18	11.0	<i>11.5</i>											
20	11.0	<i>11.5</i>	20.1/8.0	<i>20.1/8.4</i>	20.0/7.2	<i>20.0/7.5</i>							
22	11.0	<i>11.5</i>	8.0	<i>8.4</i>	7.2	<i>7.5</i>			22.3/4.6	<i>22.3/4.8</i>			
24	11.0	<i>11.5</i>	8.0	<i>8.4</i>	7.2	<i>7.5</i>	25.2/5.7	<i>25.2/6.0</i>	4.6	<i>4.8</i>			
26	11.0	<i>11.5</i>	8.0	<i>8.4</i>	7.2	<i>7.5</i>	5.7	<i>6.0</i>	4.6	<i>4.8</i>			
28	11.0	<i>11.5</i>	8.0	<i>8.4</i>	7.2	<i>7.5</i>	5.7	<i>6.0</i>	4.6	<i>4.8</i>	28.1/3.9	<i>28.1/4.1</i>	
30	11.0	<i>11.5</i>	8.0	<i>8.4</i>	7.2	<i>7.5</i>	5.7	<i>6.0</i>	4.6	<i>4.8</i>	3.9	<i>4.1</i>	
32	9.8	<i>10.2</i>	8.0	<i>8.4</i>	7.2	<i>7.5</i>	5.7	<i>6.0</i>	4.6	<i>4.8</i>	3.9	<i>4.1</i>	
34	8.9	<i>9.3</i>	8.0	<i>8.4</i>	7.2	<i>7.5</i>	5.7	<i>6.0</i>	4.6	<i>4.8</i>	3.9	<i>4.1</i>	
36	8.1	<i>8.5</i>	8.0	<i>8.4</i>	7.2	<i>7.5</i>	5.7	<i>6.0</i>	4.6	<i>4.8</i>	3.9	<i>4.1</i>	
38	8.0	<i>8.4</i>	7.2	<i>7.5</i>	37.8/7.2	<i>37.8/7.5</i>	5.7	<i>6.0</i>	4.6	<i>4.8</i>	3.9	<i>4.1</i>	
40	7.1	<i>7.4</i>	7.0	<i>7.3</i>	7.0	<i>7.3</i>	5.7	<i>6.0</i>	4.6	<i>4.8</i>	3.9	<i>4.1</i>	
42	6.7	<i>7.0</i>	6.6	<i>6.9</i>	6.5	<i>6.8</i>	5.7	<i>6.0</i>	4.6	<i>4.8</i>	3.9	<i>4.1</i>	
44	6.6	<i>6.9</i>	6.5	<i>6.8</i>	6.4	<i>6.7</i>	5.7	<i>6.0</i>	4.6	<i>4.8</i>	3.9	<i>4.1</i>	
46	6.1	<i>6.4</i>	6.1	<i>6.4</i>	6.1	<i>6.4</i>	5.7	<i>6.0</i>	4.6	<i>4.8</i>	3.9	<i>4.1</i>	
48	5.8	<i>6.1</i>	5.8	<i>6.1</i>	5.7	<i>6.0</i>	5.7	<i>6.0</i>	4.6	<i>4.8</i>	3.9	<i>4.1</i>	
50	48.1/5.7	<i>48.1/6.0</i>	48.1/5.7	<i>48.1/6.0</i>	48.1/5.7	<i>48.1/6.0</i>	48.1/5.7	<i>48.1/6.0</i>	48.1/4.6	<i>48.1/4.8</i>	48.1/3.9	<i>48.1/4.1</i>	
Counterweight	42	42+3	42	42+3	42	42+3	42	42+3	42	42+3	42	42+3	

Notes: 1.The actual lifting capacity is the rated lifting capacity indicated in the table minus the weights of all hoisting tools;  
 2.The rated lifting capacity in the figure is the weight hoisted on a level and hard ground;  
 3.The 40% orange and italic parts in the table indicate the rated loads with additional counterweight, the values of 25% orange and italic parts depend on the strength;  
 4.In order to prevent tip-over backward, the boom of over 39m long must first be connected and then additional counterweight may be mounted; any boom less than 39m long cannot use additional counterweight.



# FIXED JIB LOAD CHARTS

## SCC 1000C Crawler Crane Fixed jib load charts

unit: (t)

Boom(m)	13m						19m						25m					
Jib (m)	15°		30°		15°		30°		15°		30°		15°		30°			
Radius (m)	15°	30°	15°	30°	15°	30°	15°	30°	15°	30°	15°	30°	15°	30°	15°	30°		
18	18.3/11	<i>18.3/11.5</i>																
20	11.0	<i>11.5</i>	20.6/8.0	<i>20.6/8.4</i>	20.4/7.2	<i>20.4/7.5</i>												
22	11.0	<i>11.5</i>	8.0	<i>8.4</i>	7.2	<i>7.5</i>			23.1/4.6	<i>23.1/4.8</i>								
24	11.0	<i>11.5</i>	8.0	<i>8.4</i>	7.2	<i>7.5</i>	24.6/5.7	<i>24.6/6.0</i>	4.6	<i>4.8</i>								
26	11.0	<i>11.5</i>	8.0	<i>8.4</i>	7.2	<i>7.5</i>	5.7	<i>6.0</i>	4.6	<i>4.8</i>								
28	29.3/11.0	<i>29.3/11.5</i>	8.0	<i>8.4</i>	7.2	<i>7.5</i>	5.7	<i>6.0</i>	4.6	<i>4.8</i>	28.2/3.9	<i>28.2/4.1</i>						
30	9.7	<i>10.1</i>	8.0	<i>8.4</i>	7.2	<i>7.5</i>	5.7	<i>6.0</i>	4.6	<i>4.8</i>	3.9	<i>4.1</i>						
32	9.5	<i>9.9</i>	8.0	<i>8.4</i>	7.2	<i>7.5</i>	5.7	<i>6.0</i>	4.6	<i>4.8</i>	3.9	<i>4.1</i>						
34	8.7	<i>9.1</i>	8.0	<i>8.4</i>	7.2	<i>7.5</i>	5.7	<i>6.0</i>	4.6	<i>4.8</i>	3.9	<i>4.1</i>						
36	8.0	<i>8.4</i>	37.1/8.0	<i>37.1/8.4</i>	7.2	<i>7.5</i>	5.7	<i>6.0</i>	4.6	<i>4.8</i>	3.9	<i>4.1</i>						
38	7.8	<i>8.2</i>	7.2	<i>7.5</i>	38.7/7.2	<i>38.7/7.5</i>	5.7	<i>6.0</i>	4.6	<i>4.8</i>	3.9	<i>4.1</i>						
40	7.0	<i>7.3</i>	6.8	<i>7.1</i>	7.0	<i>7.3</i>	5.7	<i>6.0</i>	4.6	<i>4.8</i>	3.9	<i>4.1</i>						
42	6.5	<i>6.8</i>	6.4	<i>6.7</i>	6.2	<i>6.5</i>	5.7	<i>6.0</i>	4.6	<i>4.8</i>	3.9	<i>4.1</i>						
44	6.4	<i>6.7</i>	6.3	<i>6.6</i>	6.1	<i>6.4</i>	5.7	<i>6.0</i>	4.6	<i>4.8</i>	3.9	<i>4.1</i>						
46	6.0	<i>6.3</i>	6.0	<i>6.3</i>	6.0	<i>6.3</i>	47.1/5.7	<i>47.1/6.0</i>	4.6	<i>4.8</i>	3.9	<i>4.1</i>						
48	5.7	<i>6.0</i>	5.7	<i>6.0</i>	5.6	<i>5.9</i>	5.5	<i>5.8</i>	4.6	<i>4.8</i>	3.9	<i>4.1</i>						
50	5.5	<i>5.7</i>	5.4	<i>5.6</i>	5.3	<i>5.5</i>	5.2	<i>5.5</i>	4.6	<i>4.8</i>	3.9	<i>4.1</i>						
52	50.5/5.1	<i>50.5/5.3</i>	50.5/5.0	<i>50.5/5.2</i>	50.5/4.9	<i>50.5/5.1</i>	50.5/4.8	<i>50.5/5.1</i>	50.5/4.6	<i>50.5/4.8</i>	50.5/3.9	<i>50.5/4.1</i>						
Counterweight	42	42+3	42	42+3	42	42+3	42	42+3	42	42+3	42	42+3						

Boom(m)	13m						19m						25m					
Jib (m)	15°		30°		15°		30°		15°		30°		15°		30°			
Radius (m)	15°	30°	15°	30°	15°	30°	15°	30°	15°	30°	15°	30°	15°	30°	15°	30°		
18	18.2/11.0	<i>18.2/11.5</i>																
20	11.0	<i>11.5</i>	21.2/8.0	<i>21.2/8.4</i>	21.0/7.2	<i>21.0/7.5</i>												
22	11.0	<i>11.5</i>	8.0	<i>8.4</i>	7.2	<i>7.5</i>			23.5/4.6	<i>23.5/4.8</i>								
24	11.0	<i>11.5</i>	8.0	<i>8.4</i>	7.2	<i>7.5</i>	24.4/5.7	<i>24.4/6.0</i>	4.6	<i>4.8</i>								
26	11.0	<i>11.5</i>	8.0	<i>8.4</i>	7.2	<i>7.5</i>	5.7	<i>6.0</i>	4.6	<i>4.8</i>								
28	29.7/11.0	<i>29.7/11.5</i>	8.0	<i>8.4</i>	7.2	<i>7.5</i>	5.7	<i>6.0</i>	4.6	<i>4.8</i>	29.1/3.9	<i>29.1/4.1</i>						
30	9.6	<i>10.0</i>	8.0	<i>8.4</i>	7.2	<i>7.5</i>	5.7	<i>6.0</i>	4.6	<i>4.8</i>	3.9	<i>4.1</i>						
32	9.4	<i>9.8</i>	8.0	<i>8.4</i>	7.2	<i>7.5</i>	5.7	<i>6.0</i>	4.6	<i>4.8</i>	3.9	<i>4.1</i>						
34	8.5	<i>8.9</i>	8.0	<i>8.4</i>	7.2	<i>7.5</i>	5.7	<i>6.0</i>	4.6	<i>4.8</i>	3.9	<i>4.1</i>						
36	8.0	<i>8.4</i>	36.3/8.0	<i>36.3/8.4</i>	7.2	<i>7.5</i>	5.7	<i>6.0</i>	4.6	<i>4.8</i>	3.9	<i>4.1</i>						
38	7.6	<i>7.9</i>	7.2	<i>7.5</i>	38.2/7.2	<i>38.2/7.5</i>	5.7	<i>6.0</i>	4.6	<i>4.8</i>	3.9	<i>4.1</i>						
40	6.9	<i>7.2</i>	6.7	<i>7.0</i>	6.6	<i>6.9</i>	5.7	<i>6.0</i>	4.6	<i>4.8</i>	3.9	<i>4.1</i>						
42	6.4	<i>6.7</i>	6.3	<i>6.6</i>	6.2	<i>6.5</i>	5.7	<i>6.0</i>	4.6	<i>4.8</i>	3.9	<i>4.1</i>						
44	6.2	<i>6.5</i>	6.1	<i>6.4</i>	6.0	<i>6.3</i>	5.7	<i>6.0</i>	4.6	<i>4.8</i>	3.9	<i>4.1</i>						
46	5.8	<i>6.1</i>	5.7	<i>6.0</i>	5.7	<i>6.0</i>	46.8/5.7	<i>46.8/6.0</i>	4.6	<i>4.8</i>	3.9	<i>4.1</i>						
48	5.5	<i>5.7</i>	5.4	<i>5.6</i>	5.3	<i>5.5</i>	5.2	<i>5.5</i>	4.6	<i>4.8</i>	3.9	<i>4.1</i>						
50	5.4	<i>5.6</i>	5.2	<i>5.4</i>	5.1	<i>5.3</i>	5.0	<i>5.3</i>	4.6	<i>4.8</i>	3.9	<i>4.1</i>						
52	5.0	<i>5.2</i>	4.9	<i>5.1</i>	4.8	<i>5.0</i>	4.6	<i>5.0</i>	4.6	<i>4.8</i>	3.9	<i>4.1</i>						
54	52.8/4.4	<i>52.8/4.6</i>	52.8/4.3	<i>52.8/4.5</i>	52.8/4.3	<i>52.8/4.5</i>	52.8/4.3	<i>52.8/4.5</i>	52.8/4.2	<i>52.8/4.4</i>	52.8/3.9	<i>52.8/4.1</i>						
Counterweight	42	42+3	42	42+3	42	42+3	42	42+3	42	42+3	42	42+3						

Notes: 1.The actual lifting capacity is the rated lifting capacity indicated in the table minus the weights of all hoisting tools;  
 2.The rated lifting capacity in the figure is the weight hoisted on a level and hard ground;  
 3.The 40% orange and italic parts in the table indicate the rated loads with additional counterweight, the values of 25% orange and italic parts depend on the strength;  
 4.In order to prevent tip-over backward, the boom of over 39m long must first be connected and then additional counterweight may be mounted; any boom less than 39m long cannot use additional counterweight.

# FIXED JIB LOAD CHARTS

## SCC 1000C Crawler Crane Fixed jib load charts

unit: (t)

Boom(m)	13m						19m						25m					
Jib (m)	15°		30°		15°		30°		15°		30°		15°		30°			
Radius (m)	15°	30°	15°	30°	15°	30°	15°	30°	15°	30°	15°	30°	15°	30°	15°	30°		
18	18.7/11.0	<i>18.7/11.5</i>																
20	11.0	<i>11.5</i>							21.3/7.2	<i>21.3/7.5</i>								
22	11.0	<i>11.5</i>	8.0	<i>8.4</i>	7.2	<i>7.5</i>												
24	11.0	<i>11.5</i>	8.0	<i>8.4</i>	7.2	<i>7.5</i>	24.2/5.7	<i>24.2/6.0</i>										
26	11.0	<i>11.5</i>	8.0	<i>8.4</i>	7.2	<i>7.5</i>	5.7	<i>6.0</i>										
28	29.9/11.0	<i>29.9/11.5</i>	8.0	<i>8.4</i>	7.2	<i>7.5</i>	5.7	<i>6.0</i>										
30	9.4	<i>9.8</i>	8.0	<i>8.4</i>	7.2	<i>7.5</i>	5.7	<i>6.0</i>										
32	9.1	<i>9.5</i>	8.0	<i>8.4</i>	7.2	<i>7.5</i>	5.7	<i>6.0</i>										
34	8.2	<i>8.6</i>	35.1/8.0	<i>35.1/8.4</i>	7.2	<i>7.5</i>	5.7	<i>6.0</i>										
36	7.8	<i>8.2</i>	7.7	<i>8.0</i>	7.2	<i>7.5</i>	5.7	<i>6.0</i>										
38	7.4	<i>7.7</i>	7.2	<i>7.5</i>	7.2	<i>7.5</i>	5.7	<i>6.0</i>										
40	6.7	<i>7.0</i>	6.5	<i>6.8</i>	6.4	<i>6.7</i>	5.7	<i>6.0</i>										
42	6.2	<i>6.5</i>	6.1	<i>6.4</i>	6.1	<i>6.4</i>	5.7	<i>6.0</i>										
44	6.0	<i>6.3</i>	5.7	<i>6.0</i>	5.7	<i>6.0</i>	45.3/5.7	<i>45.3/6.0</i>										
46	5.6	<i>5.9</i>	5.5	<i>5.7</i>	5.4	<i>5.6</i>	5.2	<i>5.4</i>										
48	5.3	<i>5.5</i>	5.1	<i>5.3</i>	5.0	<i>5.2</i>	4.9	<i>5.1</i>										
50	5.2	<i>5.4</i>	5.0	<i>5.2</i>	4.9	<i>5.1</i>	4.7	<i>4.9</i>										
52	5.0	<i>5.2</i>	4.7	<i>4.9</i>	4.7	<i>4.9</i>	4.6	<i>4.8</i>										
54	4.3	<i>4.5</i>	4.1	<i>4.3</i>	4.1	<i>4.3</i>	4.0	<i>4.2</i>										
56	55.7/3.8	<i>55.7/4.0</i>	55.7/3.7	<i>55.7/3.9</i>	55.7/3.6	<i>55.7/3.8</i>	55.7/3.5	<i>55.7/3.7</i>										
Counterweight	42	42+3	42	42+3	42	42+3	42	42+3	42	42+3	42	42+3	42	42+3	42	42+3		

Notes: 1.The actual lifting capacity is the rated lifting capacity indicated in the table minus the weights of all hoisting tools;  
 2.The rated lifting capacity in the figure is the weight hoisted on a level and hard ground;  
 3.The 40% orange and italic parts in the table indicate the rated loads with additional counterweight, the values of 25% orange and italic parts depend on the strength;  
 4.In order to prevent tip-over backward, the boom of over 39m long must first be connected and then additional counterweight may be mounted; any boom less than 39m long cannot use additional counterweight.

### Note —— Rated load of crane

- The rated load indicated in the table is the value computed by taking 75% of the tipover load.
- All values in the load chart are suitable for 360° slewing.
- When additional counterweight (42t+3t) is used, it is an optional operating condition, rather than a standard operating condition. The boom allowing using additional counterweight is 39m~72m.





**Quality Changes the World**

**SANY HEAVY INDUSTRY CO., LTD.**

Address: 319 Chuanda Road, Chuansha Economic Park,  
Pudong, Shanghai, China, 201200

Service Hotline: +0086-21-60303131

Email: [crd@sany.com.cn](mailto:crd@sany.com.cn)

For more information, please visit: [www.sanygroup.com](http://www.sanygroup.com)

---

For our consistent improvement in technology, specifications may change without notice.  
The machines illustrated may show optional equipment which can be supplied at additional cost.