

ENGINE

Model	FPT F5H FL413 L*A001
Type	Diesel, Turbo, D.I.
Cylinders	4
Bore/Stroke	3.9 x 4.3 in (99 x 110 mm)
Displacement	207 in ³ (3.4 L)
Fuel injection	Direct
Fuel	#2 Diesel
Fuel filter:	
Pre-filter	Beta (30) = 200/spin-on
Main filter	Beta (4) = 20/spin-on
Air intake	Turbocharged w/ waste gate and external cooled EGR
Exhaust aftertreatment	Diesel particulate filter – DPF
Cooling	Liquid
Engine speeds	RPM
High idle – no load	2500 +/- 25
Rated – full load	2500
Low idle	1150 +/- 25
Horsepower @ 2500 RPM – SAE J1349:	
Gross	90 hp (67 kW)
Net	84 hp (63 kW)
Peak torque @ 1400 RPM	282 lb-ft (383 N-m)
Radiator:	
Core type	All aluminum
Core size area	2.06 ft ² (0.191 m ²)
Rows of tubes x columns	31 x 4
Cap pressure	13 +/- 2 psi (0.90 +/- 0.14 bar)
Fan:	
Diameter	22 in (560 mm)
Ratio	0.96:1 standard, 1.1:1 high-flow
Water pump:	
Style	Centrifugal
Flow	47.8 gpm (181 L/min)
Engine lubrication pump:	
Rotor pump w/ deep sump pan, plate cooler and pressurized under-piston nozzles	
Pump operating angle ratings:	
Side to side	45°
Bucket up	35°
Bucket down	45°

POWERTRAIN

Drive pump controls	Servo-assist mechanical
Pump to engine ratio	1:1
Displacement	2.81 in ³ (46 cc)
Flow @ rated engine RPM:	
@ 97% efficiency	29.4 gpm (111 L/min)
Charge pressure	360 psi (24.5 bar)
System relief pressure	5,220 psi (360 bar)
Drive pump controls	Electro-hydraulic
Pump to engine ratio	1:1
Displacement	2.75 in ³ (45 cc)
Flow @ rated engine RPM:	
@ 97% efficiency	28.8 gpm (109 L/min)
Charge pressure	362 psi (25 bar)
System relief pressure	5,220 psi (360 bar)

POWERTRAIN (cont.)

Drive motors:	
Max. displacement	28.7 in ³ (470 cc)
Displacement – optional:	
High speed	17.2 in ³ (282 cc)
Motor RPM @ high idle and 97% efficiency:	
Standard 1-speed	237
Optional 2-speed	355
Motor torque @ max. displacement and relief pressure, calculated @ 5,220 psi (360 bar):	1,987 lb-ft (2694 N-m)
Travel speed:	
Low range	7.0 mph (11.3 kph)
High range – optional	10.5 mph (16.9 kph)
Final drive	Single-reduction chain drive
Drive chain:	
Size	ASA #100
Tensile strength	30,000 lb (133.4 kN)
Axles:	
Torque @ max. displacement and relief pressure	5,957 lb-ft (8077 N-m)
Diameter	2.44 in (62 mm)
Length	15.6 in (396 mm)
Parking brake:	
Type	Spring-applied, hydraulic release multiple disc.
Engagement	Depress on/off brake button on handle or instrument panel, raise seat bar, get off seat or stop engine.

ELECTRICAL

Alternator	120 amp
Starter	4.29 hp (3.2 kW)
Battery	12-volt low-maintenance 925 cold-cranking amps @ 0° F (-18° C)

OPERATOR ENVIRONMENT

ROPS/FOPS level 1 canopy w/ side screens; Tilt ROPS/FOPS; Rear window w/ emergency escape; Top window; Instrument panel w/: hour meter, tachometer, fuel level, hydraulic oil temperature, engine coolant temperature, diagnostic features and security lockout; Non-suspension vinyl seat; 2 in (51 mm) retractable lap seat belt; Hand and foot throttles; Alarm package – back-up and horn; Headliner; Dome light; Cup holder; 12-volt power plug socket; Foot rest; Storage tray; Low effort ergonomic hand controls; Padded seat bar w/ integral armrests; Loader control lockout system; Electric parking brake control; Floor cleanout panel; Proportional auxiliary hydraulic control – on joystick.

Indicators:	Digital hourmeter; Fuel level LCD bar graph w/ alarm.
Warning lights w/ alarms:	Engine coolant temperature; Engine oil pressure; Engine malfunction; Hydraulic charge pressure; Hydraulic filter restriction; Hydraulic oil temperature.

OPERATOR ENVIRONMENT (cont.)

Warning alarms:	Battery voltage – plus display
Indicator light:	Engine preheat; Parking brake; Seat bar reminder.

OPERATING WEIGHT

Operating weight	7,700 lb (3490 kg)
Shipping weight	7,365 lb (3340 kg)
Add-on weights:	
Side cab glass	47 lb (21.3 kg)
Polycarbonate cab door	74 lb (33.6 kg)
Glass cab door w/ wiper	134 lb (60.8 kg)
Suspension seat	22 lb (10.0 kg)
Additional counterweight	300 lb (136.0 kg)

HYDRAULICS

Implement pump type	Gear
Displacement:	
Standard aux.	2.23 in ³ (36.6 cc)
High-flow aux.	1.24 in ³ (20.4 cc)
Pump flow @ rated engine RPM – 100% efficiency:	
Standard flow	24.2 gpm (91.5 L/min)
Optional high-flow	37.6 gpm (142.5 L/min)
Enhanced High-Flow	35.0 gpm (132.5 L/min)
Loader control valve:	
Type	3 spool/open center/series - series
Relief pressure	3,050 psi (210 bar)
Port relief pressures:	
Loader raise	3,263 psi (225 bar)
Bucket curl	3,770 psi (260 bar)
Bucket dump	1,160 psi (80 bar)
Hydraulic lines:	
Tubing	37° JIC Flare
Loop hoses	SAE 100 R19

Hydraulic oil cooler:	
Number of fins	10 per inch (3.94 per cm)
Number of tube rows x columns	11 x 2
Area	130.7 in ² (843.2 cm ²)

Hydraulic filter	Beta (4) = 75/spin-on
------------------	-----------------------

Lift cylinders:	
Bore diameter	2.5 in (63.5 mm)
Rod diameter	1.75 in (44.5 mm)
Stroke	32.2 in (817.9 mm)
Closed length	45.6 in (1158 mm)

Bucket cylinders:	
Bore diameter	3.0 in (76.2 mm)
Rod diameter	1.5 in (38.1 mm)
Stroke	16.4 in (410 mm)
Closed length	24.0 in (610 mm)

SERVICE CAPACITY

Fuel tank	25.5 gal (96.5 L)
Engine oil w/ filter	10.0 qt (9.4 L)
Hydraulic system:	
Reservoir	7.0 gal (26.5 L)
Total	11.75 gal (44.5 L)
Chain tanks – per side	7.4 gal (27.9 L)

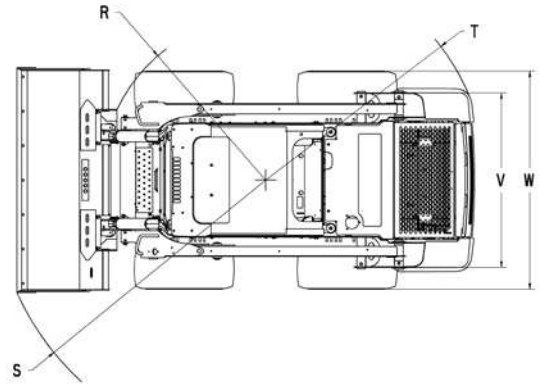
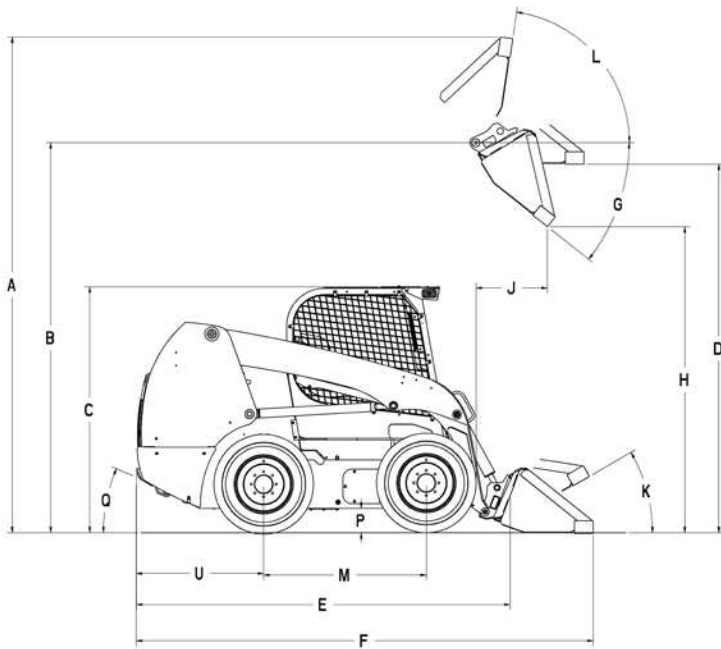

Line drawings are for illustrative purpose only and may not be exact representation of unit.

PERFORMANCE SPECS

Rated operating capacity – ROC*:	
50% of tipping load	2,500 lb (1135 kg)
with additional counterweight	2,700 lb (1225 kg)
Tipping load*	5,000 lb (2270 kg)
Breakout forces @ 3,150 psi (217 bar)*:	
Bucket cylinders	7,480 lb (33.3 kN)
Lift cylinders – tip limit	5,680 lb (25.3 kN)
Cycle times:	
Raise	3.6 sec
Lower	1.8 sec
Dump	2.6 sec
Roll back	2.0 sec

NOTE: *Measured using 72 in (1.83 m) low profile bucket.

DIMENSIONS

A. Overall operating height:	
with foundry/excavating bucket	156.3 in (3.97 m)
with low profile bucket	160.3 in (4.07 m)
with low profile extended bucket	165.3 in (4.20 m)
Height to:	
B. Bucket hinge pin	125.1 in (3.18 m)
C. Top of ROPS	78.8 in (2.00 m)
D. Bottom of level bucket, fully raised	123.3 in (3.13 m)
Overall length:	
E. without attachment with coupler	117.4 in (2.98 m)
F. with foundry/excavating bucket on ground	142.2 in (3.61 m)
with low profile bucket	146.2 in (3.71 m)
with low profile extended bucket	151.3 in (3.84 m)
G. Maximum dump angle	38.1°
H. Dump height:	
with foundry/excavating bucket	100.9 in (2.56 m) @ 38.1°
with low profile bucket	98.3 in (2.50 m) @ 38.1°
J. Dump reach at maximum height with low profile bucket	22.6 in (0.57 m) @ 38.1°
Maximum attachment rollback:	
K. Bucket on ground	30.7°
L. Bucket at full height	99.7°
M. Wheelbase	52.0 in (1.32 m)
P. Ground clearance – bottom of belly pan	8.0 in (0.20 m)
Q. Angle of departure	23.5°
Clearance circle:	
R. without bucket	55.1 in (1.40 m)
S. with 72 in (1.83 m) foundry/excavating bucket in carry position	83.5 in (2.12 m)
with 72 in (1.83 m) low profile bucket on ground	87.2 in (2.22 m)
with 72 in (1.83 m) extended low profile on ground	91.9 in (2.33 m)
T. Clearance circle rear	70.4 in (1.79 m)
U. Rear axle to bumper	40.7 in (1.03 m)
V. Tread gage with spec tires	56.9 in (1.45 m)
W. Over the tire width with spec tires	70.0 in (1.78 m)

TIRE SELECTION

Type	Size	Ply Rating	Tread Depth	Tire Width	Tread Gage	Over Tires Width	Each Tire Weight
Heavy-Duty	12 L x 16.5	—	—	—	56.9 in (1.45 m)	70 in (1.78 m)	110 lb (50 kg)
Premium	12 L x 16.5	—	—	—	56.9 in (1.45 m)	70 in (1.78 m)	119 lb (54 kg)
Premium-Lined	12 L x 16.5	—	—	—	56.9 in (1.45 m)	70 in (1.78 m)	119 lb (54 kg)
Severe Duty	12 L x 16.5	—	—	—	56.9 in (1.45 m)	70 in (1.78 m)	135 lb (61 kg)
Non-Pneumatic – Solid	12 L x 16.5	—	—	—	56.9 in (1.45 m)	70 in (1.78 m)	280 lb (127 kg)
Mining	12 L x 16.5	—	—	—	56.9 in (1.45 m)	70 in (1.78 m)	380 lb (173 kg)
Flotation	33 L x 15.5 x 16.5	—	—	—	59.0 in (1.50 m)	76 in (1.93 m)	143 lb (65 kg)
Premium	14 L x 17.5	—	—	—	62.0 in (1.58 m)	76 in (1.93 m)	148 lb (67 kg)

OPTIONAL BUCKETS

Type	Width	Weight	Heaped Capacity
Dirt & Foundry	72 in (1.83 m)	420 lb (190 kg)	16.2 ft ³ (0.46 m ³)
	78 in (1.98 m)	440 lb (200 kg)	17.7 ft ³ (0.50 m ³)
Low Profile	72 in (1.83 m)	480 lb (218 kg)	14.8 ft ³ (0.42 m ³)
Low Profile Extended	72 in (1.83 m)	510 lb (232 kg)	17.7 ft ³ (0.50 m ³)
	78 in (1.98 m)	540 lb (245 kg)	19.1 ft ³ (0.54 m ³)
	84 in (2.13 m)	575 lb (262 kg)	20.5 ft ³ (0.58 m ³)
Light Material	72 in (1.83 m)	475 lb (216 kg)	23.3 ft ³ (0.66 m ³)
	84 in (2.13 m)	540 lb (245 kg)	27.5 ft ³ (0.78 m ³)
Manure & Slurry	72 in (1.83 m)	480 lb (218 kg)	19.1 ft ³ (0.54 m ³)
	84 in (2.13 m)	545 lb (248 kg)	22.6 ft ³ (0.64 m ³)
Heavy-Duty	72 in (1.83 m)	510 lb (230 kg)	14.1 ft ³ (0.40 m ³)
	78 in (1.98 m)	530 lb (240 kg)	15.5 ft ³ (0.44 m ³)
	84 in (2.13 m)	550 lb (250 kg)	17.0 ft ³ (0.48 m ³)
Heavy-Duty with spillguard	72 in (1.83 m)	585 lb (265 kg)	18.4 ft ³ (0.52 m ³)
	78 in (1.98 m)	605 lb (275 kg)	19.8 ft ³ (0.56 m ³)
	84 in (2.13 m)	640 lb (290 kg)	21.5 ft ³ (0.61 m ³)

STANDARD EQUIPMENT

OPERATOR ENVIRONMENT

See page 1

ENGINE

FPT F5H FL413 L*A001 diesel
Over & under radiator and oil cooler
Glow plugs
Integral engine oil cooling
Fuel filter with water trap
Dual element air cleaner
120 amp alternator
925 CCA 12-volt battery
Master electrical disconnect

POWERTRAIN

1-speed hydrostatic four wheel drive
Servo-assist mechanically-controlled pumps
ASA #100HS drive chain
SAHR disc parking brake

HYDRAULICS

Auxiliary hydraulics:
@ 3,050 psi (210 bar) – 24.2 gpm (91.5 L/min)
Auxiliary hydraulic disconnects, ISO flat-face –
connect-under-pressure with case drain
Hydraulic circuit pedal lock
Loader arm-mounted ISO flat-face connectors
Auxiliary function lockout override
Loader function lockout system
Loader lift lockout override
3-spool loader control valve
Heavy-duty oil cooler
Loader arm float position

LOADER

Radial loader arm design
Mechanical attachment coupler
Loader lift arm support strut

OTHER

Machine protection auto shutdown
Mounting points for add-on counterweights
Halogen lights:
2 front
2 side
2 rear flood
Rear tail lights
Lockable service access hood
Single-point daily servicing
Pre-wired for rotating beacon
Remote oil drain
Remote oil and fuel filters

OPTIONAL EQUIPMENT

OPERATOR ENVIRONMENT

Enclosed cab:

Fully sealed and pressurized – FSP
Glass door with wiper and washer
Sliding side windows – removable
3-point seat belt – 2 in (51 mm) width
Ventilation system with integrated heater
AM/FM radio with 2 speakers
Keyless start ignition

Electro-hydraulic controls:

For drive/steering, loader functions
Switchable between H and ISO patterns
Adjustable sensitivity of controls

Vinyl mechanical suspension seat

Deluxe cloth, air suspension seat,
with heater and lumbar support

Interior mirror

3 inch (76.2 mm) retractable seat belt

Heater and air conditioner

Open cab interior trim package

Demolition cab door with polycarbonate

FOPS level 2

POWERTRAIN

2-speed hydrostatic four wheel drive

ENGINE

Coolant block heater

HYDRAULICS

High-flow auxiliary hydraulics – combined:
@ 3,050 psi (210 bar) – 37.6 gpm (142.5 L/min)
Enhanced High-Flow auxiliary hydraulics – EHF:
@ 4,000 psi (276 bar) – 35.0 gpm (132.5 L/min)
Second auxiliary hydraulics

LOADER

Auxiliary front electric control
Ride control
Hydraulic attachment coupler
Hydraulic one-way self-leveling

OTHER

Add-on counterweights
Road lights
Rotating beacon
Four-corner LED strobe
Lift points – four-point or single-point
Language decals
Factory-installed tires – see page 3
Buckets – see page 3
Bolt-on bucket cutting edges
Bolt-on heavy-duty bucket spillguard
Bolt-on heavy-duty bucket teeth – field kit
42 in (1.07 m) and 48 in (1.22 m) pallet forks
Rear door guard insert
Special paint
Debris reduction seal package
Steel tire tracks



NOTE: All specifications are stated in accordance with SAE Standards or Recommended Practices, where applicable.

NOTE: All engines meet current EPA emissions requirements.

IMPORTANT: Case Construction Equipment Inc. reserves the right to change these specifications without notice and without incurring any obligation relating to such change. Case Construction Equipment Inc. does not warrant the safety or reliability of attachments from other manufacturers.

Case is a registered trademark of CNH America LLC. Any trademarks referred to herein, in association with goods and/or services of companies other than CNH America LLC, are the property of those respective companies.

Form No. CCE201307SR250
Replaces form no. CCE201304SR250

Printed in U.S.A.
SR250 • Page 4 of 4



All Case construction equipment is biodiesel ready.



www.casece.com

© 2013 CNH America LLC
All Rights Reserved

Courtesy of Crane.Market