

Range Chart

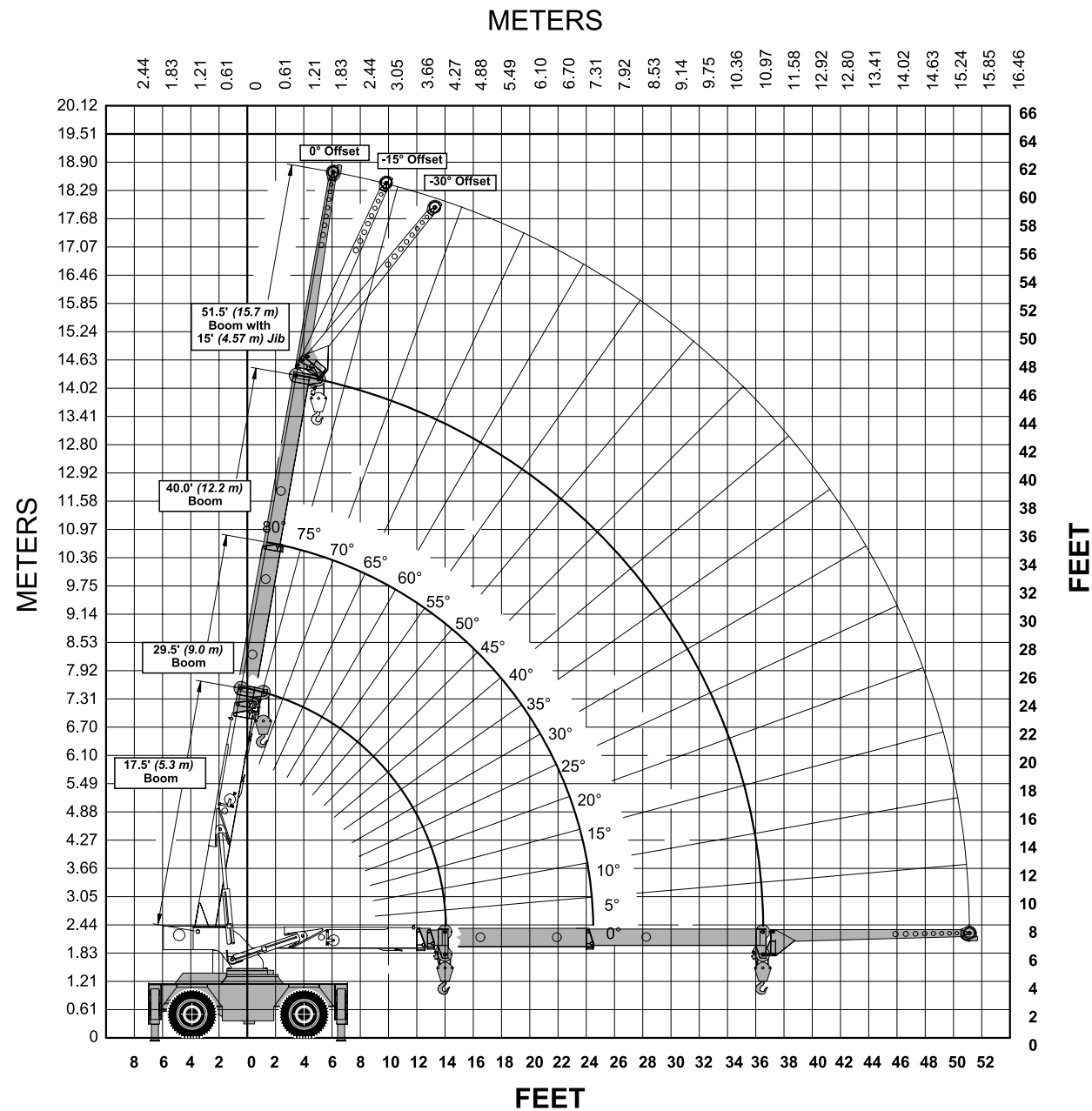

5540 3-SECTION BOOM WITH 15' (4.6 M) BOOM EXTENSION

| RATING REDUCTIONS FOR INSTALLED LOAD HANDLING DEVICES | | |
|-------------------------------------------------------|------------------|---------------------|
| DEVICE | FROM MAIN BOOM | FROM BOOM EXTENSION |
| MAIN BLOCK | 210 LB (95.3 KG) | N/A |
| HOOK & BALL | 94 LB (42.6 KG) | 94 (42.6 KG) |
| EXTENSION - STOWED | NO DEDUCTION | N/A |
| EXTENSION - DEPLOYED | 700 LB (318 KG) | NO REDUCTION |



49 E. Yew St. • PO Box 66 • Sturgeon Bay, WI • 54235-0066 USA
 Tel: (920) 743-8650 • FAX: (920) 743-1522
 E-Mail: sales@shuttlelift.com • <http://www.shuttlelift.com>

Note: Shuttlelift reserves the right to change these specifications without notice and incurring any obligation relating to such changes.

SHUTTLELIFT® Carrydeck® Industrial Cranes

MODEL 5540
15 TON
(13 600 KG)

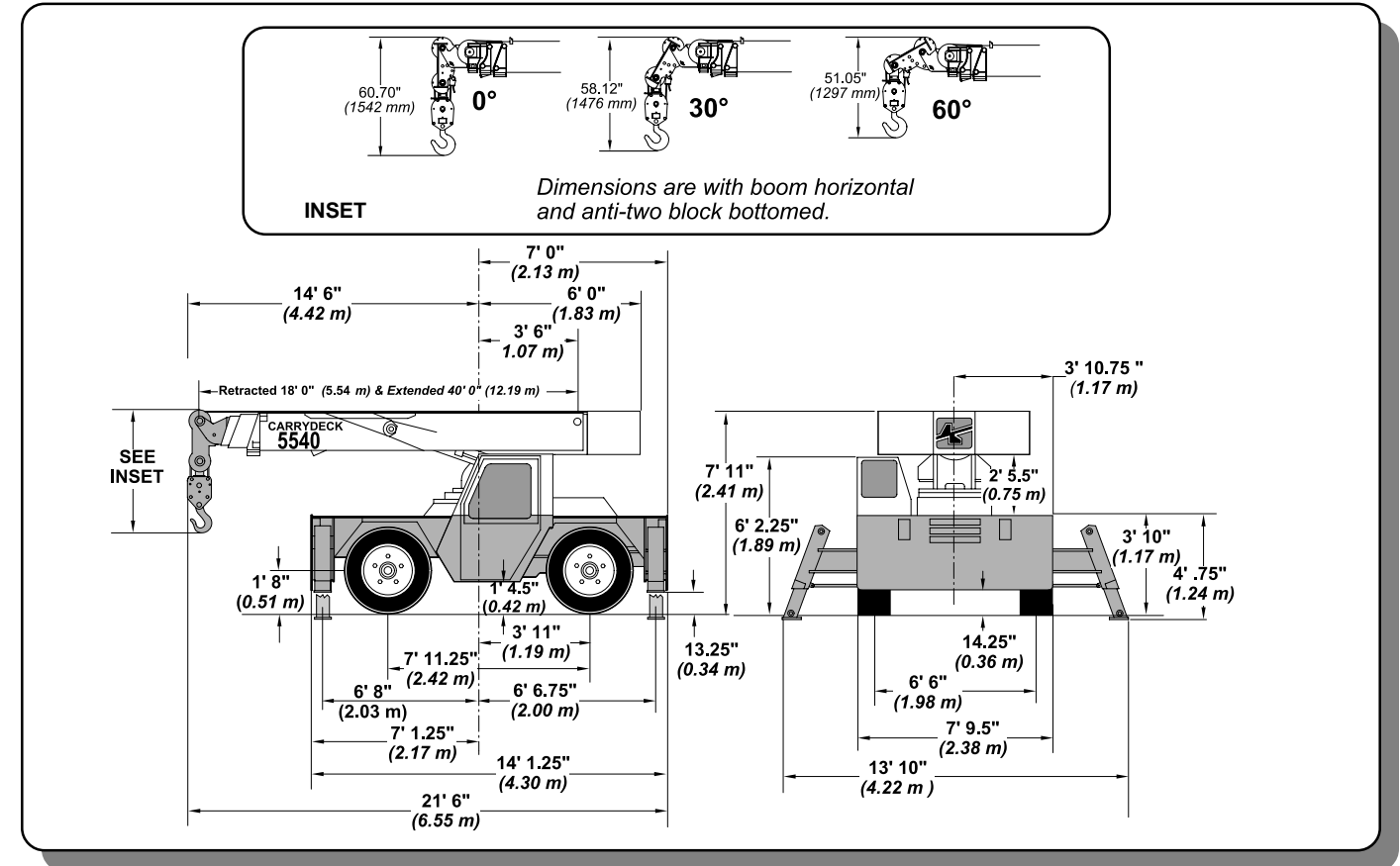

Specifications

GENERAL INFORMATION

Unit weight 26,500 lb (12 020 kg)
 Boom elevation 0° - 80°
 Ourigger pad size 8.75" x 10"
 (222 mm x 254 mm)

SERVICE CAPACITIES

Fuel tank 40 gal. (151.4 L)
 Hydraulic system 30 gal. (113.6 L)
 Hydraulic tank 40 gal. (151.4 L)
 Cooling system 23 qt. (21.8 L)
 Transmission 4 gal. (15.1 L)
 Differential
 Front axle - center 24.5 qt. (23.2 L)
 Hubs (per hub) 1.6 qt. (1.5 L)
 Rear axle - center 19 qt. (18 L)
 Hubs (per hub) 1.8 qt. (1.7 L)

WINCHES

Main winch:
 Drum diameter 9.75" (248 mm)
 Wire rope diameter 1/2" (12.7 mm)
 6 x 19EIPS-IWRC wire rope
 Wire rope length 240' (73.2 m)
 Line speed (average) (225 fpm)
 (68.6 m/min)
 Line pull, bare drum 12,000 lb
 (5443 kg)
Note: Maximum permissible single line pull 7,500 lb (3402 kg)
 Hydraulic recessed winch (optional):
 Drum diameter 4" (102 mm)
 Wire rope diameter 7/16" (11 mm)
 Wire rope length 115' (35 m)
 Line speed, first layer 26 fpm
 (7.9 m/min)
 Line pull, bare drum 10,000 lb
 (4536 kg)

STANDARD EQUIPMENT

- Hydraulic Boom:
 - 3-section, 18' 2" to 40' 0" (5.54 m to 12.19 m) from boom pivot pin to boom head pin
- Pivoting boom head (-15°, -30°, 0°, +30° & +60°)
- 4-wheel steer
- Crab steering
- 4-speed power shift transmission
- 2-wheel drive
- Left and right side outrigger controls
- Boom angle indicators (2)
- Anti-skid deck surface
- Double blocking crowd out, winch in and luff down kickout
- Electric horn
- Lights-head, tail, rear work, stop, and turn signals
- Engine hourmeter

Specifications (continued)

- All steel cab structure
- 75 ft² (6.96 m²) carrydeck. 20,000 lb. (9072 kg) deck load.
- Adjustable operator's seat with seat belt
- Engine - GM 4.3L electronic fuel injected (EFI), V6, dual fuel (gasoline or L.P. gas) with engine shutdown feature
- Lighted instrument gauges(oil pressure, engine temperature, fuel gauge, voltmeter and hourmeter)
- 80° boom elevation
- Front and rear tie down lugs
- Backup alarm
- 1 year, 2000 hour warranty (parts and labor), and 5 year structural warranty
- Outrigger - 2-stage hydraulic telescoping box - front and rear
- 15 ton (13.6 metric ton) double sheave hoist block
- Rope packer
- All load carrying cylinders include load hold check valves
- Built-in tool box
- Load Indicator

- Foam filled tires
- Fire extinguisher
- Lifting lugs (four)
- Catalytic converter for diesel engine
- 3-ton capacity searcher hook
- Engine block heater for diesel engine
- Head light and tail light grilles
- Air Conditioning

HYDRAULIC SYSTEM

Main pump ... Gear-type with three sections

Section 1 40 gpm (151.4 L)

Section 2 23 gpm (87.1 L)

Section 3 16 gpm (60.6 L)

Swing system 360° continuous swing system has positive operator control

Swing speed continuous at 2.5 rpm

System pressure 3500 psi (24 133 kPa)

HYDRAULIC CYLINDERS

CYCLE TIME

800 rpm 2500 rpm

Hoist Cylinder (full stroke):

Extend 60.0 sec 18.0 sec

Retract 44.0 sec 13.0 sec

Crowd Cylinder (full stroke):

Extend 106.0 sec 32.0 sec

Retract 53.0 sec 20.5 sec

Outriggers (individual):

Out 16.0 sec 1.8 sec

Down 42.0 sec 5.6 sec

Up 47.0 sec 4.5 sec

In 17.0 sec 1.2 sec

DRAWBAR PULL

Unit equipped with 385/65R22.5 tires, diesel engine and no load on deck:

1st gear 19,950 lb (9049 kg)

2nd gear 11,113 lb (5041 kg)

3rd gear 6,000 lb (2722 kg)

4th gear 3,500 lb (1588 kg)

ENGINE

Standard:

Make and model ... GM 4.3L electronically fuel injected, V-6

Horsepower 101 @ 2500 rpm (75.3 kw @ 2500 rpm)

Optional (Diesel) - 2WD units:

Make and model Cummins 4B3-9

Horsepower 80 @ 2500rpm (57 kw @ 2500 rpm)

Optional (Diesel) - 4WD units:

Make and model Cummins 4BT3.9

Horsepower 110 @ 2500 rpm (82 kw @ 2500 rpm)

OPTIONAL EQUIPMENT

- Enclosed cab with windshield wiper and sliding right side window
- Suspension seat
- Independent outrigger controls (four controls)
- Cummins 4BT3.9 diesel engine (4-wheel drive units)
- Cummins 4B3.9 diesel engine (2-wheel drive units)
- Four-wheel drive with oscillating rear axle (1.5°)
- Rough terrain package with oscillating rear axle (4°) and axle lockouts

ACCESSORIES AND ATTACHMENTS

- Cold start kit (Ether injector and second battery)
- Load moment indicator (LMI) system
- Flashing amber strobe light
- Rear hitch (pintle)
- Front hitch (pintle)
- Swing away boom extension - 15' (4.6 m) offsets 15° and 30° with standard pivoting boom head
- Single part line down haul block
- Hydraulic recessed winch
- Heater and defroster (hot water)
- Spare wheel and tire
- Engine shut down gauges (diesel)
- Two-man work platform
- Dual rearview mirrors
- Spark arrestor muffler

ELECTRICAL

Starting system 12 volt electric

Battery (1) 820 CCA @ 0° F (-18° C)

Alternator 63 amp

TRANSMISSION

Type power shift transmission 4-speed forward/reverse with electronic control unit (ECU) for shifting protection

Unit standard with transmission oil cooler and filter.

FRONT AXLE

Rigid mounted planetary drive/steer with limited slip differential.

REAR AXLE

Two-Wheel Drive

Steer axle with 1.5° of oscillation

Four-Wheel Drive (optional)

Planetary drive/steer axle with 1.5° of oscillation, or 4° of oscillation.

BRAKES

Service Brakes Front and rear, internal wet disc, hydraulic actuated

Parking Brake Hand lever actuated, disc on axle differential

TIRE SIZE

385/65R22.5 radial, high traction tread

TURNING SPECIFICATIONS

Turning radius: to centerline of outside wheels

Two-wheel steer 21' 6" (6.55 m)

Four-wheel steer 12' 4" (3.76 m)

TRAVEL SPEEDS

Standard tires, diesel engine:

1st gear 4 mph (6.4 k/h)

2nd gear 7 mph (11.3 k/h)

3rd gear 13 mph (20.9 k/h)

4th gear: 21mph (33.8 k/h)

MAXIMUM GRADEABILITY (Paved Surface)

1st gear (calculated, standard tires, diesel engine):

No load 68%

20,000 lb (9072 kg) load 40%

Note: All specifications are stated in accordance with PCSA and ANSI B30.5 definitions, SAE standards or recommended practices, where applicable.

Rated Load Capacities

| Operating Radius | *On Extended and Down Outriggers Less Boom Extension 360° or Retracted and Down Front/Rear | | | | | | | | | On Rubber Less Boom Extension 360° | |
|------------------|--------------------------------------------------------------------------------------------|-----------------------|-----------------------|--------------------|-----------------------|-----------------------|---------------------|-----------------------|-----------------------|------------------------------------|---------------------|
| | **On Retracted and Down Outriggers Less Boom Extension 360° | | | | | | | | | | |
| | 17.5' (5.3 m) Boom | | | 29.5' (9.0 m) Boom | | | 40.5' (12.3 m) Boom | | | Any Boom Length | |
| | Boom Angle | *Rated Load | **Rated Load | Boom Angle | *Rated Load | **Rated Load | Boom Angle | *Rated Load | **Rated Load | Front Rating | 360° Rating |
| 6' (1.8 m) | 63° | 30,000 lb (13 608 kg) | 30,000 lb (13 608 kg) | 74° | 29,100 lb (13 200 kg) | 29,100 lb (13 200 kg) | 79° | 25,500 lb (11 567 kg) | 25,500 lb (11 567 kg) | 16,000 lb (7258 kg) | 10,900 lb (4944 kg) |
| 8' (2.4 m) | 55° | 29,600 lb (13 426 kg) | 27,200 lb (12 338 kg) | 70° | 28,600 lb (12 973 kg) | 28,000 lb (12 701 kg) | 76° | 24,200 lb (10 977 kg) | 24,200 lb (10 977 kg) | 13,100 lb (5942 kg) | 8,700 lb (3946 kg) |
| 10' (3.0 m) | 45° | 23,200 lb (10 886 kg) | 17,000 lb (7711 kg) | 66° | 23,600 lb (10 705 kg) | 16,600 lb (7530 kg) | 73° | 21,400 lb (9707 kg) | 17,000 lb (7711 kg) | 10,800 lb (4899 kg) | 7,100 lb (3221 kg) |
| 12' (3.7 m) | 34° | 18,900 lb (8573 kg) | 12,000 lb (5443 kg) | 62° | 19,300 lb (8754 kg) | 11,500 lb (5216 kg) | 70° | 18,800 lb (8528 kg) | 12,800 lb (5806 kg) | 8,900 lb (4037 kg) | 5,950 lb (2698 kg) |
| 14' (4.3 m) | 0° | 15,900 lb (7212 kg) | 9,100 lb (4128 kg) | 57° | 16,300 lb (7394 kg) | 8,700 lb (3946 kg) | 66° | 16,400 lb (7439 kg) | 9,400 lb (4264 kg) | 7,100 lb (3221 kg) | 5,000 lb (2268 kg) |
| 16' (4.9 m) | - | - | - | 52° | 14,000 lb (6350 kg) | 7,200 lb (3266 kg) | 63° | 14,200 lb (6441 kg) | 7,450 lb (3379 kg) | 5,850 lb (2654 kg) | 4,200 lb (1905 kg) |
| 18' (5.5 m) | - | - | - | 47° | 11,750 lb (5330 kg) | 6,000 lb (2722 kg) | 60° | 12,000 lb (5443 kg) | 5,900 lb (2676 kg) | 4,800 lb (2177 kg) | 3,500 lb (1588 kg) |
| 20' (6.1 m) | - | - | - | 41° | 9850 lb (4468 kg) | 4,900 lb (2223 kg) | 56° | 10,000 lb (4536 kg) | 4,900 lb (2223 kg) | 3,950 lb (1792 kg) | 2,850 lb (1293 kg) |
| 22' (6.7 m) | - | - | - | 34° | 8,400 lb (3810 kg) | 4,000 lb (1814 kg) | 53° | 8,500 lb (3856 kg) | 4,080 lb (1851 kg) | 3,300 lb (1497 kg) | 2,350 lb (1066 kg) |
| 24' (7.3 m) | - | - | - | 25° | 7,200 lb (3266 kg) | 3,350 lb (1520 kg) | 49° | 7,300 lb (3311 kg) | 3,500 lb (1588 kg) | 2,750 lb (1247 kg) | 1,960 lb (889 kg) |
| 26' (7.9 m) | - | - | - | 0° | 6,300 lb (2858 kg) | 2,850 lb (1293 kg) | 45° | 6,400 lb (2903 kg) | 3,000 lb (1361 kg) | 2,400 lb (1089 kg) | 1,680 lb (762 kg) |
| 28' (8.5 m) | - | - | - | - | - | - | 40° | 5,650 lb (2563 kg) | 2,600 lb (1179 kg) | 2,050 lb (930 kg) | 1,400 lb (635 kg) |
| 30' (9.1 m) | - | - | - | - | - | - | 36° | 5,000 lb (2268 kg) | 2,300 lb (1043 kg) | 1,850 lb (839 kg) | 1,200 lb (544 kg) |
| 32' (9.8 m) | - | - | - | - | - | - | 30° | 4,500 lb (2041 kg) | 1,950 lb (885 kg) | 1,600 lb (726 kg) | 1,000 lb (454 kg) |
| 34' (10.4 m) | - | - | - | - | - | - | 23° | 4,000 lb (1814 kg) | 1,800 lb (817 kg) | 1,400 lb (635 kg) | 850 lb (386 kg) |
| 36.5' (11.1 m) | - | - | - | - | - | - | 0° | 3,550 lb (1610kg) | 1,500 lb (680 kg) | 1,200 lb (544 kg) | 670 lb (304 kg) |

SHADED AREAS ARE GOVERNED BY STRUCTURAL STRENGTH. DO NOT RELY ON TIPPING.

NOTE: For rated reductions for installed load handling equipment, see back page.

NOTE: These charts are only a guide and should not be used to operate the crane. The individual crane load charts, operating instructions and other instructional information must be read and understood prior to operating the crane.

| 15' (4.6 m) Boom Extension Capacities on Extended and Down Outriggers | | | | | | | | | | | |
|-----------------------------------------------------------------------|---------------------|--------------------|--------------------|-----|--------------------|--------------------|-------------------|-----|-------------------|-------------------|-----|
| Main Boom Angle (Deg) | Offset Angle | | | | Offset Angle | | | | Offset Angle | | |
| | 0° | 15° | 30° | | 0° | 15° | 30° | | 0° | 15° | 30° |
| 80° | - | 5,000 lb (2268 kg) | 3,500 lb (1588 kg) | 50° | 3,400 lb (1542 kg) | 2,600 lb (1179 kg) | 2,100 lb (953 kg) | 20° | 2,200 lb (998 kg) | 2,000 lb (907 kg) | - |
| 75° | *7,500 lb (3402 kg) | 4,400 lb (1996 kg) | 3,100 lb (1406 kg) | 45° | 3,050 lb (1384 kg) | 2,400 lb (1089 kg) | 2,000 lb (907 kg) | 15° | 2,100 lb (956 kg) | 1,950 lb (885 kg) | - |
| 70° | *6,100 lb (2767 kg) | 3,900 lb (1769 kg) | 2,800 lb (1270 kg) | 40° | 2,800 lb (1270 kg) | 2,250 lb (1021 kg) | 1,950 lb (885 kg) | 10° | 2,050 lb (930 kg) | - | - |
| 65° | 5,000 lb (2268 kg) | 3,500 lb (1588 kg) | 2,550 lb (1157 kg) | 35° | 2,600 lb (1179 kg) | 2,150 lb (975 kg) | 1,900 lb (862 kg) | 5° | 2,020 lb (916 kg) | - | - |
| 60° | 4,300 lb (1951 kg) | 3,150 lb (1429 kg) | 2,350 lb (1066 kg) | 30° | 2,400 lb (1089 kg) | 2,080 lb (944 kg) | 1,850 lb (839 kg) | 0° | 2,000 lb (907 kg) | - | - |
| 55° | 3,800 lb (1724 kg) | 2,850 lb (1293 kg) | 2,200 lb (998 kg) | 25° | 2,300 lb (1043 kg) | 2,050 lb (930 lb) | - | | | | |

* Do not exceed 29.5' (9.0 m) main boom length.