



SJ63 AJ

ARTICULATING BOOM

STANDARD FEATURES

- Axle based 4WD system
- Operator controlled locking rear differential and limited slip front differential
- Oscillating axle
- Drivable at full height
- 360° continuous turret rotation
- 45% Gradeability
- Diesel or dual fuel engine
- Swing out engine tray
- Swing up cowlings
- Modular platform railing system
- Tri-entry sliding mid-rails
- 110V AC outlet on platform with GFI
- Direction sensing drive and steer controls
- Proportional controls
- Relay based control system
- Color coded and numbered wiring
- Hourmeter
- Operator horn
- All motion alarm
- Tie down/lifting lugs
- Wet disc SAHR brakes (front and rear axle)
- 10.5 x 17.5 grip lug air-filled tires
- Telematics ready

* Standard lead times may be increased when optional equipment is added, consult factory.

† Capacities, and machine weights may differ when options are added.

‡ Certain option pricing not available at time of printing.

ACCESSORIES AND OPTIONS

- 32 x 72" Platform
- 3.5 kW generator (includes hydraulic oil cooler)
- Welder ready package (includes 12 kW generator, hydraulic oil cooler, 3 phase power connection in platform, and welder mount.)
- Welder package (includes 12 kW generator, hydraulic oil cooler, 3 phase power connection in platform, welder mount and Lincoln V275-S welder)
- Cold weather start kit (includes cold start engine oil, battery blanket, and hydraulic tank heater)
- Arctic weather package (includes arctic engine oil, battery blanket, hydraulic tank heater, block heater, arctic hydraulic oil, arctic platform rotator and arctic gear oil in the axels and swing drive. Glow plugs, arctic hydraulic hoses (all), and oversized foot switch cover are also included (standard equipment).
- Extra propane tank and bracket (dual fuel only)
- Hydraulic oil cooler
- Flashing light
- 1/2" airline to platform
- Positive air shut-off valve
- Non destructive testing
- Glazier kit
- Hostile environment package (Includes cylinder bellows, boom wipers, covers for the fly boom cutouts, and control box cover)
- Auxiliary top rail (36 x 96" platform only)
- Control box cover
- Pipe rack
- Side gate
- Warranty Options (3 year or 5 year plans available)

TIRE OPTIONS

- Grip lug air-filled non-marking tires
- Grip lug foam-filled non marking tires
- Grip lug foam-filled tires
- High flotation air-filled tires

SJ63 AJ ARTICULATING BOOM

Dimensions	SJ63 AJ
Work Height	69'7" (21.21 m)
Platform Height	63'7" (19.38 m)
Horizontal Reach	40' (12.19 m)
Up and Over Height	27'6" (8.38 m)
A Platform Size	36" x 96" (0.91 x 2.4 m)
B Stowed Width	96" (2.44 m)
C Tailswing	Zero
D Stowed Height	100" (2.54 m)
E Stowed Length	30' (9.14 m)
F Wheelbase	8' (2.44 m)
G Ground Clearance	13" (0.33 m)

Specifications	SJ63 AJ
Rotation	360°
Platform Rotation	170°
Jib Length	5' 6" (1.68 m)
Jib Range +/-	+65° / -60°
Weight	21,200 lbs (9,616 kg)
Gradeability	45%
Turning Radius (Inside)	7'3" (2.21 m)
Turning Radius (Outside)	17'5" (5.31 m)
Axle Oscillation	4" (10.16 m)
Drive Speed (High speed)	4.5 mph (7.3 km/h)
Capacity	500 lbs (227 kg)
Local Floor Load (With Rated Load)	167 psi (1,151 kPa)
Overall Floor Load (With Rated Load)	245 psf (11.73 kPa)
Maximum # of Persons	2
Tire Type	Grip lug air-filled
Tire Size	10.5 x 17.5
Diesel Engine	74 HP
Dual Fuel Engine	82 HP
Fuel Tank Capacity	30.4 gal. (115L)
Hydraulic Reservoir	30.4 gal. (115L)

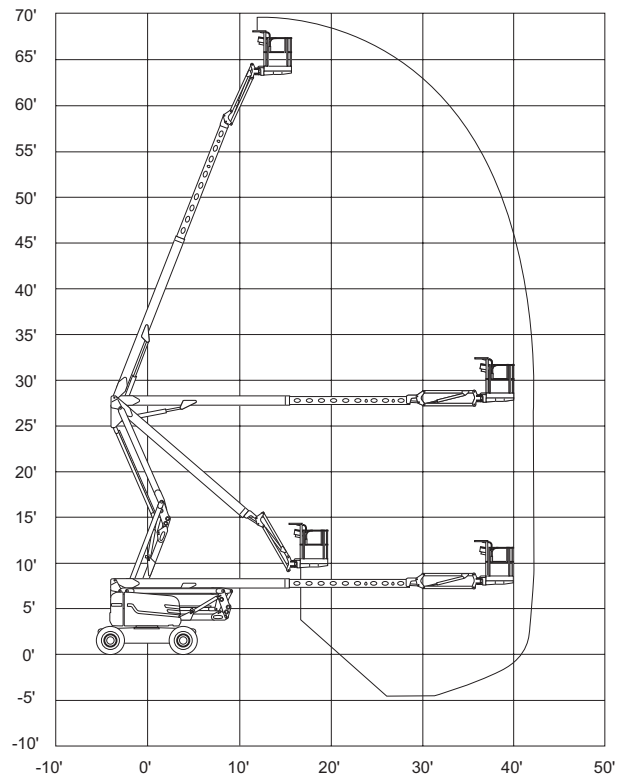
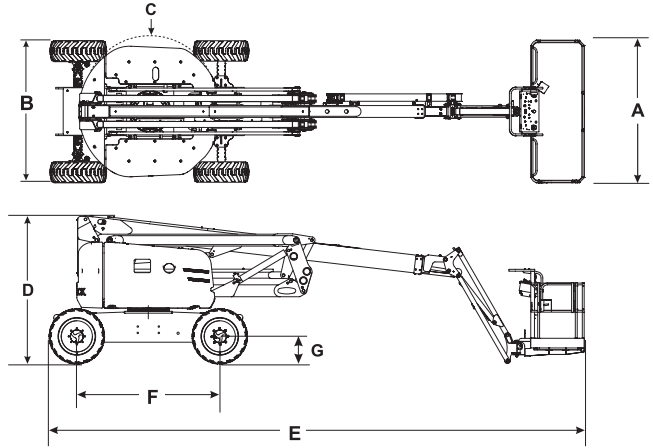

SJ63 AJ Work Height

Skyjack Head Office

55 Campbell Rd. Guelph, ON Canada N1H 1B9
 Sales Inquiries: 1-877-755-4387 (1-877-SJLIFTS)
 Main Switchboard: 1-800-265-2738
 Phone: 519-837-0888
 Fax: 519-837-8104
 Email: skyjack@skyjack.com
 www.skyjack.com

This brochure is for illustrative purpose only and based on the latest information at the time of printing. Skyjack Inc. reserves the right to make changes at any time, without notice, to specifications, standard and optional equipment. Consult the Operating Maintenance and Parts Manuals for proper procedures. Work platforms have been tested to comply with ANSI and CSA standards as interpreted by Skyjack Inc.

