

SJ6832 RTE

ELECTRIC ROUGH TERRAIN SCISSOR



STANDARD FEATURES

- Crossover symmetrical 4WD
- Drivable at full height with roll out deck fully extended
- 5' roll out extension deck
- 16hp AC electric motor with motor controller
- 48V 250Ah battery pack
- Low voltage battery protection
- Multiple wet disc spring applied, hydraulic release (SAHR) brakes
- 110V AC outlet on platform with GFI
- 45% Gradeability
- Standard foam filled grip lug non-marking tires
- Tilt alarm with drive & lift cut-out
- Lanyard attachment points
- All motion audible alarm
- Operator horn
- Hinged railing system
- Forklift pockets and tie down/lift lugs
- Full height spring-hinged gate at rear of unit
- Relay based control system
- Color coded and numbered wiring
- Telematics ready

ACCESSORIES AND OPTIONS

- Independent/auto leveling outriggers
- Hybrid Power Pack (2.2kW Genset)
- 800W AC Inverter
- High Capacity AGM Batteries (330 Ah)
- Flashing Light
- Non destructive testing
- Warranty Options (3 year or 5 year plans available)

* Standard lead times may be increased when optional equipment is added, consult factory.

† Capacities, and machine weights may differ when options are added.

SJ6832 RTE ROUGH TERRAIN SCISSOR

Dimensions	SJ6832 RTE
A Work Height	38' (11.58 m)
B Raised Platform Height	32' (9.75 m)
C Lowered Platform Height	54" (1.37 m)
D Overall Width	69.5" (1.76 m)
E Overall Length	107" (2.72 m)
F Stowed Height (Rails Up)	99" (2.51 m)
G Stowed Height (Rails Down)	69" (1.75 m)
H Platform Width (Inside Dimension)	56" (1.42 m)
I Platform Length (Inside Dimension)	96" (2.44 m)
Specifications	SJ6832 RTE
Extension Deck	5' (1.52 m)
Ground Clearance	8" (0.20 m)
Wheelbase	80.5" (2.04 m)
Weight	7,885 lbs (3,577 kg)
Gradeability	45%
Turning Radius (Inside)	60" (1.52 m)
Turning Radius (Outside)	156" (3.96 m)
Lift Time (With Rated Load)	39 sec
Lower time (With Rated Load)	36 sec
Drive Speed (Stowed)	3.5 mph (5.6 km/h)
Drive Speed (Raised)	0.4 mph (0.6 km/h)
Maximum Drive Height	Full Height
Capacity (Overall)	1,000 lbs (454 kg)
Distributed Capacity (Main Platform)	700 lbs (318 kg)
Distributed Capacity (Extension Deck)	300 lbs (136 kg)
Local Floor Load (With Rated Load)	184 psi (1269 kPa)
Overall Floor Load (With Rated Load)	281 psf (13 kPa)
Maximum # of Persons	4
Tire Type	Foam Filled Non-Marking
Tire Size	26 x 12

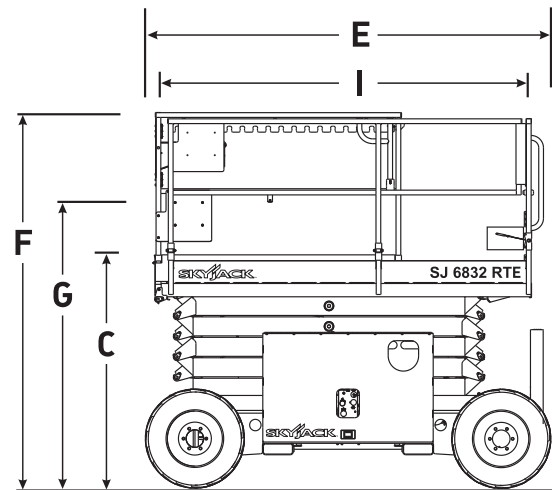
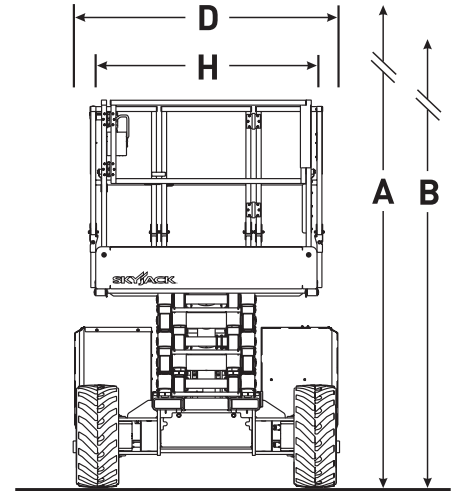

Skyjack Head Office

55 Campbell Rd. Guelph, ON Canada N1H 1B9
 Sales Inquiries: 1-877-755-4387 (1-877-SJLIFTS)
 Main Switchboard: 1-800-265-2738
 Phone: 519-837-0888
 Fax: 519-837-8104
 Email: skyjack@skyjack.com
 www.skyjack.com

This brochure is for illustrative purpose only and based on the latest information at the time of printing. Skyjack Inc. reserves the right to make changes at any time, without notice, to specifications, standard and optional equipment. Consult the Operating Maintenance and Parts Manuals for proper procedures. Work platforms have been tested to comply with ANSI and CSA standards as interpreted by Skyjack Inc.

