



MODELS | SJIII 3215 SJIII 3219



COMPACT SERIES DC Electric SCISSOR LIFTS

The Compact Series DC Electric Scissor Lifts offer Skyjack's easy to service, low maintenance design in a compact and versatile package. Equipped with variable speed front wheel hydraulic drive, and 90° steering, both models in the Compact Series are capable of maneuvering in the smallest spaces.

Featuring a 3' roll out extension deck, these Compact Series models offer work heights up to 25' and 25% gradeability. Both platforms boast an industry leading capacity; 600lbs on the SJIII 3215 and 550lbs on the SJIII 3219.

The SJIII 3215 and SJIII 3219 feature durable steel swing-out component trays, providing unrestricted access for easy maintenance and service.

Consistent with Skyjack's robust and reliable design features, the Compact Series DC Electric Scissor lifts utilize Skyjack's standard color coded and numbered wiring system with analog based controls.

COMPACT SERIES

DC Electric Scissor Lifts

Specifications	SJIII 3215	SJIII 3219
A Work Height	21' (6.4 m)	25' (7.6 m)
B Raised Platform Height	15' (4.6 m)	19' (5.8 m)
C Lowered Platform Height	34.5" (0.9 m)	39" (1.0 m)
D Overall Width	32" (0.8 m)	32" (0.8 m)
E Overall Length	70" (1.8 m)	70" (1.8 m)
F Stowed Height (Rails Up)	74" (1.9 m)	78.5" (2.0 m)
G Stowed Height (Rails Down)	OPT 60.1" (1.5 m)	OPT 64.5" (1.6 m)
H Platform Width (Inside Dimension)	26" (0.7 m)	26" (0.7 m)
I Platform Length (Inside Dimension)	64" (1.6 m)	64" (1.6 m)
Extension Deck (Roll Out)	3' (0.9 m)	3' (0.9 m)
Ground Clearance (Stowed)	2.375" (6.0 cm)	2.375" (6.0 cm)
Ground Clearance (raised)	0.7" (1.8 cm)	0.7" (1.8 cm)
Wheelbase	55" (1.4 m)	55" (1.4 m)
Weight	2,400 lbs (1,089 kg)	2,580 lbs (1,170 kg)
Gradeability	25%	25%
Turning Radius (Inside)	0"	0"
Turning Radius (Outside)	66" (1.7 m)	66" (1.7 m)
Lift Time (With Rated Load)	23 sec	25 sec
Drive Speed (Stowed)	2 mph (3.2 km/h)	2 mph (3.2 km/h)
Drive Speed (Raised)	0.7 mph (1.1 km/h)	0.7 mph (1.1 km/h)
Maximum Drive Height	Full Height	Full Height
Capacity (Overall)	600 lbs (272 kg)	550 lbs (249 kg)
Maximum # of Persons	2	2

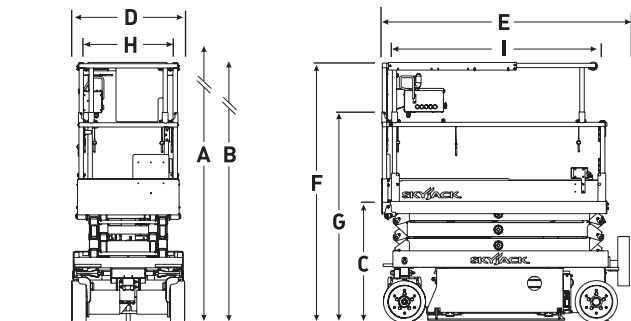

STANDARD FEATURES

- Drivable at full height
- Variable speed, front two wheel hydraulic drive
- 90° steering (zero inside turning radius)
- Dual holding brakes
- Proportional controls for drive & lift functions
- 3' (0.9m) roll out extension deck
- 24V DC power source
- Low voltage battery protection
- Analog control system
- Color coded and numbered wiring system
- 25% gradeability
- Solid rubber, non-marking tires
- Pothole protection system
- 110V AC outlet on platform with GFI
- Tilt alarm with drive & lift cut-out
- All motion audible alarm
- Operator horn
- Lanyard attachment points
- Forklift pockets and tie down/lift lugs

OPTIONS†

- Flashing light
- Shop airline to platform
- 800 watt AC inverter
- EE rating package
- Hinged railing system
- Half height spring hinged gate
- Full height spring hinged gate*

*not available with hinged railing system

† Capacities, and machine weights may differ when options are added

Skyjack Head Office

55 Campbell Rd. Guelph, ON Canada N1H 1B9

Sales Inquiries: 1-877-755-4387 (1-877-SJLIFTS)

Main Switchboard: 1-800-265-2738

Phone: 519-837-0888

Fax: 519-837-8104

Email: skyjack@skyjack.com

www.skyjack.com

This brochure is for illustrative purpose only and based on the latest information at the time of printing. Skyjack Inc. reserves the right to make changes at any time, without notice, to specifications, standard and optional equipment. Consult the Operating Maintenance and Parts Manuals for proper procedures. Work platforms have been tested to comply with ANSI and CSA standards as interpreted by Skyjack, Inc.

