



MODELS | SJIII 4626 SJIII 4632



CONVENTIONAL SERIES DC Electric SCISSOR LIFTS

The Conventional Series DC Electric Scissor Lifts offer high capacity and large platform areas, making them suitable for any on-slab application. Featuring variable speed rear wheel hydraulic drive, the Conventional Series offers working heights up to 38', and 25% gradeability.

A standard 4' roll out extension deck can be secured in multiple positions, and both models can be driven at full height. Consistent with Skyjack's robust and reliable design features, the Conventional Series DC Electric Scissor Lifts utilize Skyjack's standard color coded and numbered wiring system with analog based controls.

CONVENTIONAL SERIES DC Electric Scissor Lifts

Specifications	SJIII 4626	SJIII 4632
A Work Height	32' (9.8 m)	38' (11.6 m)
B Raised Platform Height	26' (7.9 m)	32' (9.8 m)
C Lowered Platform Height	45" (1.1 m)	48.5" (1.2 m)
D Overall Width	46" (1.2 m)	46" (1.2 m)
E Overall Length	91" (2.3 m)	91" (2.3 m)
F Stowed Height (Rails Up)	84.5" (2.1 m)	88" (2.2 m)
G Stowed Height (Rails Down)	70.5" (1.8 m)	74" (1.9 m)
H Platform Width (Inside Dimension)	42" (1.1 m)	42" (1.1 m)
I Platform Length (Inside Dimension)	84" (2.1 m)	84" (2.1 m)
Extension Deck (Roll Out)	4' (1.2 m)	4' (1.2 m)
Ground Clearance (Stowed)	3.5" (8.9 cm)	3.5" (8.9 cm)
Ground Clearance (raised)	0.75" (1.9 cm)	0.75" (1.9 cm)
Wheelbase	69" (1.8 m)	69" (1.8 m)
Weight	4,700 lbs (2,132 kg)	5,075 lbs (2,302 kg)
Gradeability	25%	25%
Turning Radius (Inside)	47.5" (1.2 m)	47.5" (1.2 m)
Turning Radius (Outside)	93.5" (2.4 m)	93.5" (2.4 m)
Lift Time (With Rated Load)	54 sec	59 sec
Drive Speed (Stowed)	2 mph (3.2 km/h)	2 mph (3.2 km/h)
Drive Speed (Raised)	0.7 mph (1.1 km/h)	0.7 mph (1.1 km/h)
Maximum Drive Height	Full Height	Full Height
Capacity (Overall)	1,000 lbs (454 kg)	700 lbs (318 kg)
Maximum # of Persons	3	2

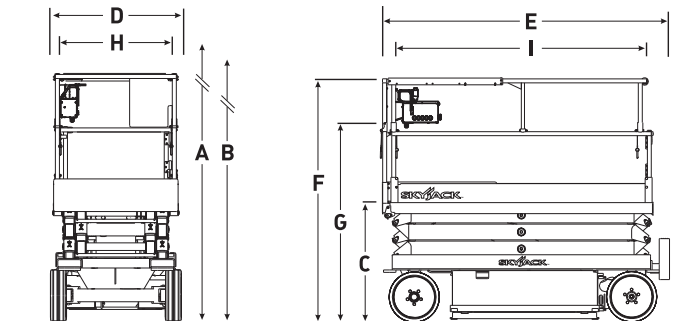

STANDARD FEATURES

- Drivable at full height
- Variable speed, rear two wheel hydraulic drive
- Dual holding brakes
- Proportional controls for drive & lift functions
- 4' (1.2 m) roll out extension deck
- 24V DC power source
- Low voltage battery protection
- Analog control system
- Color coded and numbered wiring system
- 25% gradeability
- Solid rubber, non-marking tires
- Pothole protection system
- 110V AC outlet on platform with GFI
- Tilt alarm with drive & lift cut-out
- All motion audible alarm
- Operator horn
- Hinged railing system
- Lanyard attachment points
- Forklift pockets and tie down/lift lugs

OPTIONS†

- Flashing light
- 6' powered extension deck (4626 only)*
*adds 280 lbs to unit weight and capacity remains the same
- Shop airline to platform
- 800 watt AC inverter
- 250 Ah batteries
- Half height spring hinged gate
- Full height spring hinged gate
- EE rating package
- Air operation package

† Capacities, and machine weights may differ when options are added

Skyjack Head Office

55 Campbell Rd. Guelph, ON Canada N1H 1B9
 Sales Inquiries: 1-877-755-4387 (1-877-SJLIFTS)
 Main Switchboard: 1-800-265-2738
 Phone: 519-837-0888
 Fax: 519-837-8104
 Email: skyjack@skyjack.com

www.skyjack.com

This brochure is for illustrative purpose only and based on the latest information at the time of printing. Skyjack Inc. reserves the right to make changes at any time, without notice, to specifications, standard and optional equipment. Consult the Operating Maintenance and Parts Manuals for proper procedures. Work platforms have been tested to comply with ANSI and CSA standards as interpreted by Skyjack, Inc.

