

MHP 13/35

TRAILER MOUNTED BOOM LIFT



- Safe and stable working height of up to 12.6m
- Heavy duty trailer mounted articulated boom lift
- Robust steel platform with two man capacity
- Easy to use outrigger/boom safety interlocks
- Ideal for a wide range of construction, building and maintenance applications

 **snorkel**
www.snorkellifts.com

TRAILER MOUNTED BOOM LIFTS MHP 13/35

DIMENSIONS MHP13/35

Max. working height	12.6m
Max. platform height (A)	10.6m
Horizontal outreach	5.6m at 6m
Platform size	1.25m x 0.78m x 1.07m
Outrigger footprint	3.7m x 3.9m
Overall width (outriggers extended)	3.95m
Overall width (outriggers retracted) (B)	1.58m
Overall length (C)	5.99m
Transport height (D)	2.05m

PERFORMANCE

Platform capacity	227kg
Platform capacity (with rotator)	200kg
Max. wind speed	12.5m/sec
Max. towing speed	80km/h
Levelling	Mechanical
Turntable rotation	540° non-continuous
Tyres	185 R14
Brakes	Hydraulic disc
Max. axle capacity	1,750kg
Trailer tongue weight	65kg

POWER

Power source	Honda petrol engine 5.5hp
Hydraulic system	Proportional electro/hydraulic

WEIGHT

Gross weight	1,360kg
--------------	---------

WORKING ENVELOPE

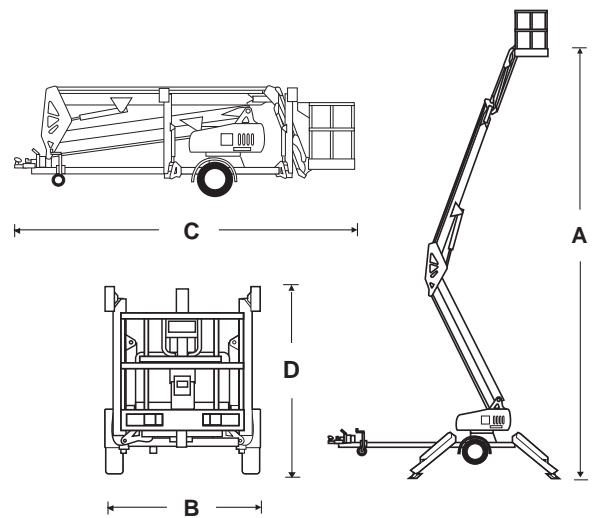
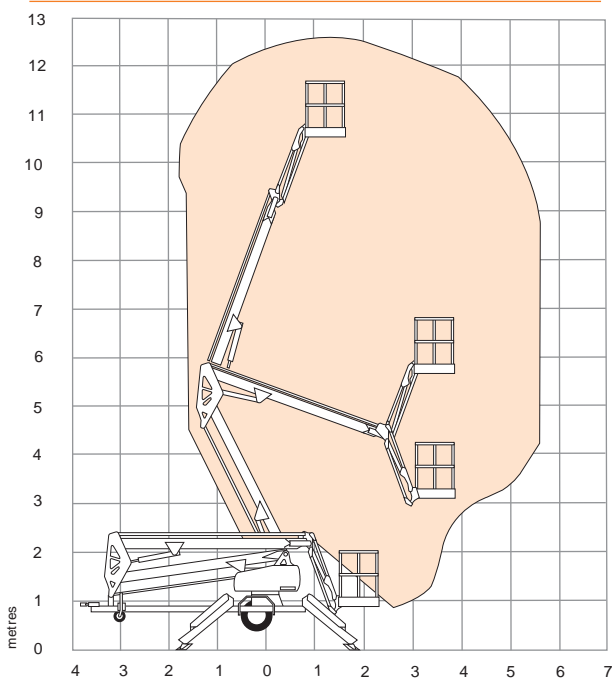

STANDARD FEATURES

- High strength steel boom and base construction
- Proportional speed control
- Heavy duty tow coupling
- Heavy duty jockey wheel
- Hydraulic disc brakes
- Reliable petrol engine
- Versatile jib boom (+70° to -70°)
- Articulating boom sections for 'up & over' reach
- 600V AC rated cable to platform
- Two man steel platform
- Automatic stabilisers
- Outrigger/boom safety interlocks
- Lockable hinged covers
- Hour meter
- Lifting lugs
- Independently operated hydraulic outriggers

OPTIONS

- 360° continuous rotation turntable
- Flashing light
- 110/240V AC GFCI power to platform
- Platform rotator
- Diesel and Bi-energy options

snorkel www.snorkellifts.com

2/26 Redfern Street,
Wetherill Park,
NSW 2164, Australia
t: +61 1300 900 700

e: sales.au@snorkellifts.com