

Snorkel

Operator's Manual

MHP 15/44

**Engine Powered
Gasoline/Diesel
Battery Electric**

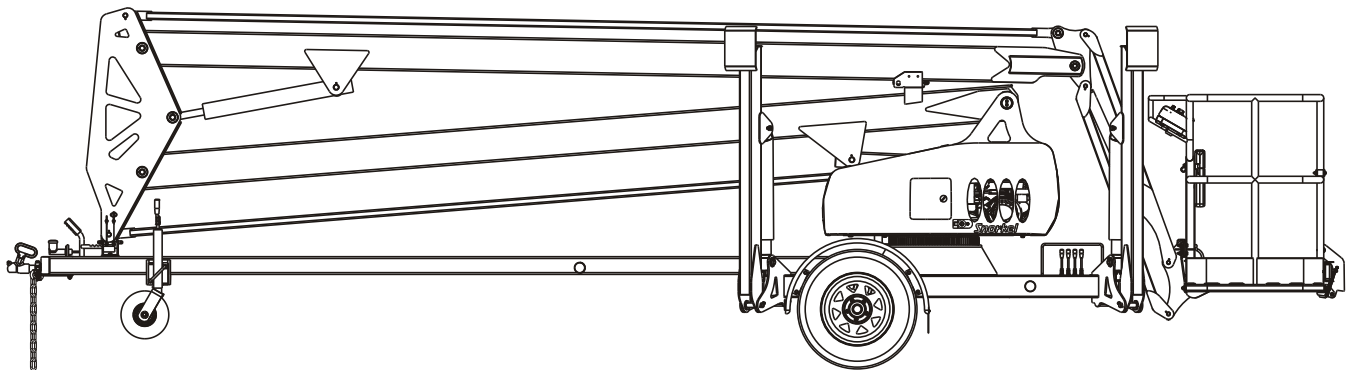

P/N 12459A
July 2006 (v8b)

LIMITED WARRANTY

Snorkel warrants each new machine manufactured and sold by it to be free from defects in material and workmanship for a period of one (1) year from date of delivery to a Customer or for one year after the machine has been placed in first service in a Dealer rental fleet, whichever comes first. Any part or parts which, upon examination by the Snorkel Service Department, are found to be defective, will be replaced or repaired, at the sole discretion of Snorkel, through its local Authorized Dealer at no charge.

Snorkel further warrants the structural components; specifically, the mainframe chassis, turntable, booms and scissor arms, of each new machine manufactured by it to be free from defects in material and workmanship for an additional period of four (4) years. Any such part or parts which, upon examination by the Snorkel Service Department, are found to be defective will be replaced or repaired by Snorkel through its local Authorized Dealer at no charge; however, any labor charges incurred as a result of such replacement or repair will be the responsibility of the Customer or Dealer.

The Snorkel Service Department must be notified within forty-eight (48) hours of any possible warranty situation during the applicable warranty period. Personnel performing warranty repair or replacement must obtain specific approval by Snorkel Service Department prior to performing any warranty repair or replacement.

Customer and Dealer shall not be entitled to the benefits of this warranty and Snorkel shall have no obligations hereunder unless the "Pre-Delivery and Inspection Report" has been properly completed and returned to the Snorkel Service Department within ten (10) days after delivery of the Snorkel product to Customer or Dealer's rental fleet. Snorkel must be notified, in writing, within ten (10) days, of any machine sold to a Customer from a Dealer's rental fleet during the warranty period.

At the direction of the Snorkel Service Department, any component part(s) of Snorkel products to be replaced or repaired under this warranty program must be returned freight prepaid to the Snorkel Service Department for inspection. All warranty replacement parts will be shipped freight prepaid (standard ground) from the Snorkel Service Department or from Snorkel's Vendor to Dealer or Customer.

REPLACEMENT PARTS WARRANTY

Any replacement or service part made or sold by Snorkel is not subject to the preceding **Limited Warranty** beyond the normal warranty period of the machine upon which the part was installed.

THIS WARRANTY EXCLUDES AND SNORKEL DOES NOT WARRANT:

1. Engines, motors, tires and batteries which are manufactured by suppliers to Snorkel, who furnish their own warranty. Snorkel will, however, to the extent permitted, pass through any such warranty protection to the Customer or Dealer.
2. Any Snorkel product which has been modified or altered outside Snorkel's factory without Snorkel's written approval, if such modification or alteration, in the sole judgment of Snorkel's Engineering and/or Service Departments, adversely affects the stability, reliability or service life of the Snorkel product or any component thereof.
3. Any Snorkel product which has been subject to misuse, improper maintenance or accident. "Misuse" includes but is not limited to operation beyond the factory-rated load capacity and speeds. "Improper maintenance" includes but is not limited to failure to follow the recommendations contained in the Snorkel Operation, Maintenance, Repair Parts Manuals. Snorkel is not responsible for normal maintenance, service adjustments and replacements, including but not limited to hydraulic fluid, filters and lubrication.
4. Normal wear of any Snorkel component part(s). Normal wear of component parts may vary with the type application or type of environment in which the machine may be used; such as, but not limited to sandblasting applications.
5. Any Snorkel product that has come in direct contact with any chemical or abrasive material.
6. Incidental or consequential expenses, losses, or damages related to any part or equipment failure, including but not limited to freight cost to transport the machine to a repair facility, downtime of the machine, lost time for workers, lost orders, lost rental revenue, lost profits or increased cost.

This warranty is expressly in lieu of all other warranties, representations or liabilities of Snorkel, either expressed or implied, unless otherwise amended in writing by Snorkel's President, Vice President-Engineering, Vice President-Sales or Vice President-Marketing.

SNORKEL MAKES NO WARRANTIES WHICH EXTEND BEYOND THE DESCRIPTION OF THIS LIMITED WARRANTY. SNORKEL MAKES NO IMPLIED WARRANTY OF MERCHANTABILITY OR FITNESS FOR A PARTICULAR PURPOSE AND DISCLAIMS ALL LIABILITY FOR INCIDENTAL OR CONSEQUENTIAL DAMAGES, INCLUDING BUT NOT LIMITED TO INJURY TO PERSONS OR PROPERTY.

The Customer shall make all warranty claims through its local Authorized Dealer and should contact the Dealer from whom the Snorkel product was purchased for warranty service. Or, if unable to contact the Dealer, contact the Snorkel Service Department for further assistance.

Effective July 1995

■ Electrical Hazard Warning

 **DANGER**

**THE MHP AERIAL WORK PLATFORM
IS NOT ELECTRICALLY INSULATED.**

If the platform, booms, or any other conductive part of a MHP contacts a high-voltage electrical conductor, the result can be **SERIOUS INJURY** or **DEATH** for persons on or near the machine.



**GO NO CLOSER THAN THE MINIMUM SAFE APPROACH DISTANCES
(M.S.A.D) - AS OUTLINED IN TABLE 1. AND FIGURE 3.,
ON THE NEXT PAGE.**

Be sure to allow for sag and sway in the wires and the work platform.

If a MHP comes in contact with a live electrical conductor, the entire machine can be charged.

If that happens, you should remain on the machine and not contact any other structure or object within reach. That includes the ground, adjacent buildings, poles, and any object not a part of the MHP.

Such contact could make your body a conductor to the other object creating an electrical shock hazard resulting in **SERIOUS INJURY** or **DEATH**.

DO NOT attempt to enter or leave the MHP until you are sure the electricity has been turned off.

If a MHP is in contact with a live conductor, the platform operator **MUST** warn others on the ground in the vicinity of the MHP to **STAY AWAY** from the machine, since their bodies can also form a path for electricity to ground thus creating an electrical shock hazard with possible **ELECTROCUTION** and **DEATH**.

DO NOT attempt to operate the MHP ground controls when the platform, booms, or any other conducting part of a MHP is in contact with electrical wires or if there is an immediate danger of such contact.

Regard all conductors as energized.

Personnel working on or near a MHP must be continuously aware of electrical hazards, recognizing that **SERIOUS INJURY** or **DEATH** can result if contact with an electrical wire does occur.

Electrical Hazard

■ Minimum Safe Approach Distance

The MHP is an all metal boom, **NOT ELECTRICALLY INSULATED**, aerial work platform. **DO NOT** operate it near **ELECTRICAL** conductors. Regard all conductors as being energized. Use the table and illustration below to determine safe clearance from electrical conductors. (Table 1 and Figure 3, below, are from ANSI/SIA A92.5–1992 Standard, reprinted with permission of Scaffold Industry Association.)

□ Table 1 - (M.S.A.D.)

**Minimum Safe Approach Distance
to energized (exposed or insulated power lines)**

Voltage range (phase to phase)	Minimum safe approach distance	
	(Feet)	(Meters)
0 to 300V	Avoid contact	
over 300v to 50kv	10	3.05
over 50kv to 200kv	15	4.60
over 200kv to 350kv	20	6.10
over 350kv to 500kv	25	7.62
over 500kv to 750kv	35	10.67
over 750kv to 1000kv	45	13.72

□ Figure 3 - (M.S.A.D.)

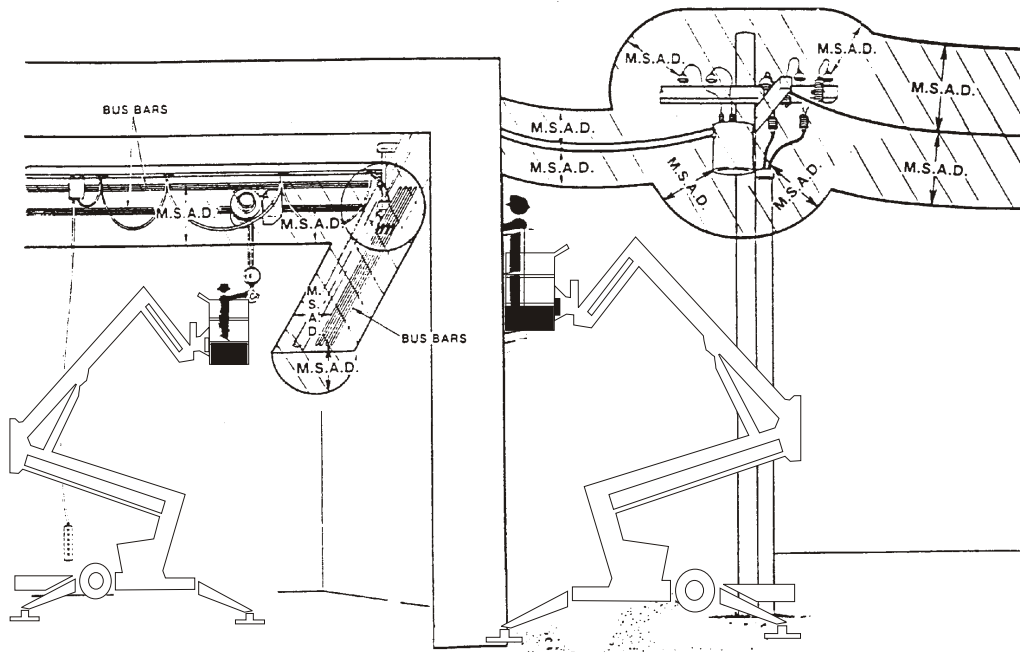

Denotes prohibited zone

- Danger:**
- Do not allow machine personnel or conductive materials inside prohibited zone.
 - Maintain M.S.A.D. From all energised lines and parts as well as those shown.
 - Assume all electrical parts and wires are energised unless known otherwise.
- Caution:**
- Diagrams shown are only for purposes of illustrating M.S.A.D. Work positions, not all work positions.

The most important chapter in this manual is the safety chapter - Chapter 1. Take time, now, to study it closely. The information in Chapter 1, might save your life, prevent serious injury, or damage to property or the MHP15/44.

■ Standard MHP15/44

The standard MHP15/44 includes the following features:

- Proportional speed control
- Versatile jib boom
- Heavy duty tow coupling
- Heavy duty jockey wheel
- Hydraulic disc brakes
- High strength steel boom and base construction
- Reliable gasoline engine
- Steel platform - 2 man capacity
- 600V AC rated wire to platform
- Hour meter
- Lockable hinged covers
- Outrigger/boom interlocks
- Independently operated hydraulic outriggers
- Gravity gate

■ Options

The following options are available for the MHP15/44:

- 360° continuous rotation turntable
- Flashing light
- 110/240V AC GFCI power to platform
- Platform rotator
- Lifting lugs
- Automatic stabilisers
- Alternative power options
 - Alternative gasoline engine
 - Diesel engine
 - 24V DC battery power
 - 110/240V AC motor and pump
 - Combinations of the above with gas or diesel to give a bi-energy power source
- Sand blast protection kit

■ Operation Manual

This manual provides information for safe and proper operation of the aerial platform. Read and understand the information in this Operator's manual before operating this machine on a job site.

Additional copies of this manual may be ordered from Snorkel. Supply the model and manual part number from the front cover to ensure that the correct manual will be supplied.

All information in this manual is based on the latest product information at the time of publication. Snorkel reserves the right to make product changes at any time without obligation.

■ Safety Alerts

A safety alert symbol is used throughout this manual to indicate danger, warning and caution instructions. Follow these instructions to reduce the likelihood of personal injury, property damage or damage to the machine.

The terms danger, warning, and caution indicate varying degrees of personal injury or property damage that can result if the instruction is not followed.

▲ DANGER

Denotes an imminently hazardous situation which, if not avoided, will result in death or serious injury.

▲ WARNING

Denotes a potentially hazardous situation which, if not avoided, could result in death or serious injury.

▲ CAUTION

Denotes a potentially hazardous situation which, if not avoided, may result in minor or moderate injury.

It may also be used to alert against unsafe practices or action which may result in damage to the MHP.

▲ IMPORTANT

Denotes important information pertaining to settings, capacities, conditions, which could, if ignored lead to machine damage or future hazardous situations.

Notes

Notes are used to provide special information or helpful hints to assist in aerial platform operation, but do not indicate a hazardous situation.

■ Operation

The MHP aerial platform has built in safety features and has been factory tested for compliance with Snorkel specifications and industry standards. However, any personnel lifting device can be

Introduction

potentially dangerous in the hands of untrained or careless operators.

Training is vitally important and must be performed under the direction of a QUALIFIED person. You must display proficiency in knowledge and actual operation of the MHP before using it on a job site.

Before operation of the MHP you must read and understand the operating instructions in this manual as well as the decals, warnings, and instructions on the machine itself.

Before operating the MHP you must be AUTHORIZED by the person in charge to do so and the operation of the MHP must be within the scope of the machine specifications.

▲ WARNING

The potential for an accident increases when the aerial platform is operated by personnel who are not trained and authorised. Death or serious injury can result from such accidents. read and understand the information in this manual and on the placards and decals on the machine before operating the MHP on the job site.

■ Maintenance

Every person who maintains, inspects, tests, or repairs these machines, and every person supervising any of these functions, must be properly trained and qualified to do so.

This Operator's Manual provides a daily inspection procedure that will help you keep your MHP in good operating condition.

Do not perform other maintenance unless you are a trained mechanic, qualified to work on the MHP. Call qualified maintenance personnel if you find problems or malfunctions.

Do not modify this machine without written approval from the Engineering Department of Snorkel. Modification may void the warranty, adversely affect stability, or affect the operational characteristics of the MHP.

■ Responsibilities of parties

It is imperative that all owners and users of the MHP read, understand, and conform to all applicable regulations. Ultimate compliance to OSHA regulations is the responsibility of the user and their employer.

▲ WARNING

ANSI Standard A92.2-2001 clearly identifies requirements of all parties who might be involved with Boom-Supported Elevating Work Platforms.

AUSTRALIAN / NZ STANDARD 2550-10 1994 Also identifies the requirements of all parties who might be involved with Boom-Supported Elevating Work Platforms.

A reprint of the "Manual of Responsibilities for Dealers, Owners, Users, Operators, Lessors and Lessees of ANSI/SIA A92.5-1992 Boom Supported Elevating Work Platforms" is available from Snorkel dealers or from the factory upon request.

Copies are also available from:

Scaffold Industry Association, Inc.,
P.O. Box 1160
Phoenix, AZ 85036-0574 USA

■ In summary

- Only trained and authorised operators should be permitted to operate the equipment.
- All manufacturer's operating instructions and safety rules and all employers' safety rules and all OSHA and other government safety rules should be strictly adhered to.
- Repairs and adjustments should be made only by qualified and trained maintenance personnel.
- No modification should be made to the equipment without prior written consent of the Snorkel Engineering Department.
- Make a pre-start inspection of the MHP at the beginning of each shift. A malfunctioning machine must not be used.
- Make an inspection of the work place to locate possible hazards before operating the MHP.

■ Additional information

For additional information, contact your local dealer or Snorkel at:

Snorkel International
2/26 Redfern Street
Wetherill Park NSW 2164
Australia

Snorkel International
PO Box 1041
Levin 5500
New Zealand

Electrical Hazard

Electrical Hazard Warning	i
Minimum Safe Approach Distance	ii
Table 1 - (M.S.A.D.)	ii
Figure 3 - (M.S.A.D.)	ii

Introduction

Standard MHP15/44.	iii
Options.	iii
Operation Manual.	iii
Safety Alerts.	iii
Operation	iii
Maintenance	iv
Responsibilities of parties	iv
In summary	iv
Additional information	iv

1. Safety

Safe Operation	1-1
Electrocution Hazards	1-1
Minimum safe approach distance	1-1
Pre-start Inspection	1-1
Work Place Inspection and Practices	1-1
Operation.	1-2
Tipover and Falling Hazards	1-3
General Safety Precautions	1-3
Hydraulic System Precautions	1-3
Fire Prevention	1-3
Engine and Fuel Handling Precautions.	1-4
Batteries	1-4
Safety Decals and Placards	1-4

2. Safety Devices

Safety Device Information	2-1
Emergency Stop Switches	2-1
At ground control box	2-1
At platform control box	2-1
Other Safety Devices	2-1
Lanyard anchor points	2-1
Gravity gate.	2-2
Guardrails	2-2
Foot switch	2-2
Bubble level	2-2
RCD/ELCB AC outlet	2-3
Flashing light.	2-3

3. Specifications

General Specifications	3-1
Recommended Hydraulic Oil.	3-2
Engine Data.	3-2
Overall Dimensions - MPH15/44.	3-3
Working Envelope - MHP15/44.	3-4
Booms identification	3-5

Nomenclature And Serial Numbers.	3-5
Right side view of machine	3-5
Left side view of machine	3-6

4. Gauges

Hourmeter	4-1
Level Bubble	4-1
Hydraulic Oil Level	4-1

5. Automatic Shut-offs and Circuit Breakers

RCD/ELCB Outlet (option)	5-1
Main Circuit Breaker	5-1
Outriggers	5-1

6. Controls

Controls Description	6-1
Controls and Control Decals Locations	6-1
Ground Control Box.	6-2
Lower controls:	6-2
Ground Control Box Controls	6-2
Platform Control Box	6-3
Upper controls:	6-3
Stabiliser Controls	6-4
Self Levelling Stabilisers (Option)	6-4

7. Daily Inspection and Maintenance

Daily Inspection and Maintenance Table	7-1
Engine Fuel Level	7-2
Fuel Tank Cap.	7-2
Fuel Leaks	7-2
Engine Oil Level	7-2
Operator's Manual	7-2
Wiring Harnesses	7-2
Battery Terminals	7-3
Battery Fluid Level.	7-3
Hydraulic Oil Level	7-3
Hydraulic Oil Leaks	7-3
Bolts and Fasteners	7-4
Wheels and Tyres	7-4
Structural Damage and Welds	7-5
Lanyard Anchor Points	7-5
Platform Gravity Gate	7-5
Platform Guardrails	7-6
Flashing Light (option).	7-6
Ground Control Switches	7-6
Emergency Lower	7-6
Lower control box	7-6
Upper control box	7-7
Platform Control Switches	7-7
AC Outlet RCD/ELCB (option)	7-7
Placards and Decals	7-7
Standard placards and decals	7-7
Inspection drawing	7-9

Table of Contents

8. Operation

Operating Procedures	8-1
Control Stations	8-1
Emergency Stopping Lower Control Box	8-1
Emergency Stopping Upper Control Box	8-1
Operation Considerations	8-2
Starting From Ground Control Box	8-2
Stabiliser Operation	8-2
Self Levelling Stabilisers (Option)	8-2
Setting the stabilisers manually	8-3
Starting From Platform Control Box	8-3
Moving The Platform	8-4
From Ground Control Box	8-4
From Platform Control Box	8-5
Securing for Day	8-5

9. Emergency Operation

Emergency Operation Procedures	9-1
Operation From Platform Control Box	9-1
Operation From Ground Control Box	9-2

10. Stowing and Transporting

Stowing	10-1
The correct stowed position is shown here.	10-1
Transporting	10-1
Trailing	10-1
Securing to a Transport Vehicle	10-2
Towing	10-2
Forklift points	10-2

11. Options

Air Line To Platform	11-1
Dual Fuel	11-1
24V DC Battery Power	11-1
Bi-Energy	11-1
Work Lights	11-1
Flashing Light	11-1
RCD/ELCB AC Outlet	11-1
Sandblast Protection Kit	11-1
Platform Rotator	11-1

12. Fire Fighting and Chemical Containment

Hazardous Components	12-1
Battery, Lead/Acid (UN 2794)	12-1
Gasoline (UN 1203)	12-2
Hydraulic Oil (UN 1270)	12-3
Motor Oil (UN 1270)	12-3

13. Operator's Troubleshooting

Troubleshooting	13-1
Operator Troubleshooting Chart	13-1

■ Safe Operation

Knowledge of the information in this manual, and proper training, provide a basis for safely operating the MHP15/44. Know the location of all the controls and how they operate to act quickly and responsibly in an emergency.

Safety devices reduce the likelihood of an accident. Never disable, modify, or ignore any safety device. Safety alerts in this manual indicate situations where accidents may occur.

If any malfunction, hazard or potentially unsafe condition relating to capacity, intended use, or safe operation is suspected, stop the operation of the MHP and seek assistance.

The operator bears ultimate responsibility for following all manufacturers instructions and warnings, regulations and safety rules of their employer and/or any country or regional law.

■ Electrocution Hazards

The MHP is an all metal boom aerial work platform and is not electrically insulated. Do not operate it near electrical conductors. Regard all conductors as being energized. Do not operate outside during a thunderstorm.

□ Minimum safe approach distance

Minimum safe approach distances to energized power lines and their associated parts must be observed while operating the MHP.

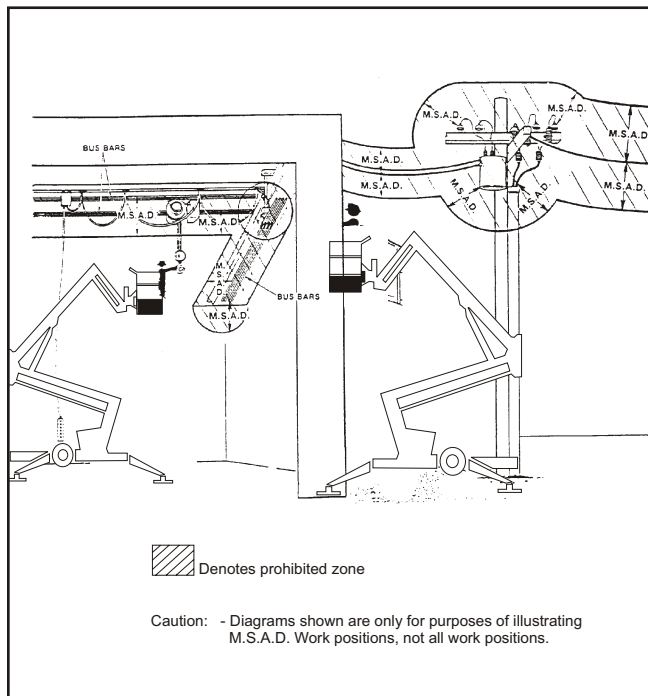

Figure 1. - Minimum Safe Approach Distance

▲ DANGER

The MHP is not electrically insulated. Death or serious injury can result from contact with, or inadequate clearance from, an energised conductor. Do not go closer than the minimum safe approach distance as defined by ANSI.

ANSI publications define minimum distances that must be observed when working near bus bars and energised power lines. Figure 1 and Table 1 are reprinted courtesy of the Scaffold industry Association, ANSI/SIA A92.5.

Voltage Range (Phase to Phase)	Minimum Safe Approach Distance	
	Feet	Metres
0 to 300V	Avoid Contact	
Over 300V to 50kV	10	3.05
Over 50kV to 200kV	15	4.60
Over 200kV to 350kV	20	6.10
Over 350kV to 500kV	25	7.62
Over 500kV to 750kV	35	10.7
Over 750kV to 1000kV	45	13.72

Table 1. - Minimum Safe Approach Distance

■ Pre-start Inspection

At the start of each work shift, the MHP15/44 shall be given a visual inspection and function test. See the “Daily Inspection and Maintenance” chapter 7, in this manual for a list of items to inspect and test.

▲ WARNING

DO NOT operate the MHP15/44 unless you are trained and authorized, understand the operation characteristics of the MHP15/44, and have inspected and tested all functions to be sure they are in proper working order.

■ Work Place Inspection and Practices

Do not use the MHP15/44 as a ground for welding. Ground to the work piece.

Before the MHP15/44 is used, and during use, check the area in which the MHP15/44 is to be used for possible hazards such as, but not limited to:

- Drop-offs or holes.
- Side slopes.

1. Safety

- Bumps and floor obstructions.
- Debris.
- Overhead obstructions and electrical conductors.
- Hazardous locations.
- Inadequate surface and support to withstand all load forces imposed by the aerial platform in all operating configurations.
- Wind and weather conditions.
- Presence of unauthorized persons.
- Other possible unsafe conditions.

Before the MHP15/44 is used, determine the hazard classification of any particular atmosphere or location according to ANSI/NFPA 505-1987.

Any MHP15/44 operated in a hazardous location must be approved and of the type required by ANSI/NFPA 505-1987.

While operating the MHP a recommended safety practice is to have trained and qualified personnel in the immediate work area of the MHP15/44 to:

- Help in case of an emergency.
- Operate emergency controls as required.
- Watch for loss of control by platform operator.
- Warn the operator of any obstructions or hazards that may not be obvious to them.
- Watch for soft terrain, sloping surfaces, drop-offs, etc., where stability could be jeopardized.
- Watch for bystanders and never allow anyone to be under, or to reach through the booms while operating the aerial platform.

▲ DANGER

Pinch points may exist between moving components. Death or serious injury can result from becoming trapped between components, buildings, structures, or other obstacles. Make sure there is sufficient clearance around the machine before moving the chassis, booms, or platform. Allow sufficient room and time to stop movement to avoid contact with structures or other hazards.

Keep ground personnel from under the platform when the platform is raised.

Secure all accessories, containers, tools, and other materials in the platform to prevent them from accidentally falling or being kicked off the platform.

Always look in the direction of travel. Drive with care and at speeds compatible with the work-place conditions. Use caution when driving over rough ground, on slopes, and when turning.

Do not engage in any form of “horseplay” or “stunt driving” while operating the MHP15/44.

Do not permit riders on the machine anywhere other than on the platform.

Remove all loose objects stored in or on the machine, particularly in the platform. Remove all objects which do not belong in or on the machine.

Never steady the platform by positioning it against another platform.

Do not operate an MHP15/44 that is damaged or not functioning properly. Do not use the MHP until the machine has been repaired by a qualified maintenance person.

Do not operate a MHP15/44 that does not have all its decals and placards attached and legible.

Watch for bystanders and never allow anyone to be under, or to reach through, the machine and its equipment while operating.

Use the recommended transport device when loading the machine.

■ Operation

If you encounter any suspected malfunction of the aerial platform, or any hazard or potentially unsafe condition relating to capacity, intended use, or safe operation, cease operation immediately and seek assistance from management.

Use three points of support when getting on or off the platform (two hands and one foot or a similar set of points). Keep the platform clean.

Maintain a firm footing on the platform floor. Operate the controls slowly and deliberately to avoid jerky and erratic operation. Always stop the controls in neutral before going in the opposite direction.

Do not dismount while the platform is in motion or jump off the machine.

Do not start until all personnel are clearly away from the machine.

Never cover the floor grating or otherwise obstruct your view below. Make sure the area below the platform is free of personnel before lowering.

■ Tipover and Falling Hazards

Operate the MHP only on a firm, flat, level surface capable of withstanding all load forces imposed by the MHP15/44 in all operating conditions.

▲ DANGER

The MHP can tip over if it becomes unstable. Death or serious injury can result from a tip-over accident. Do not drive or position the MHP platform for elevated use near any drop-off, hole, slope, soft or uneven ground, or other tip-over hazard.

Do not operate the MHP15/44 from a position on trucks, trailers, railway cars, floating vessels, scaffolds, or similar equipment unless the application is approved in writing by Snorkel.

Care shall be taken to prevent rope, electric cords, and hoses, etc., from becoming entangled in the aerial platform. If the platform or elevating assembly becomes caught, snagged, or otherwise prevented from normal motion by an adjacent structure or other obstacle such that control reversal does not free the platform, remove all personnel from the platform before attempts are made to free the platform using ground controls.

Under normal working conditions it is best not to transfer from the platform to another structure or vice versa, unless that is the safest way to do the job. Each situation must be judged separately taking the work environment into account. The following guidelines apply:

1. Where possible, place the work platform over a roof or walking structure to do the transfer.
2. Transfer your anchorage from one structure to another before you step across.
3. Remember, you might be departing the work platform to a structure where fall arrest is required.
4. Do not climb over or through the guardrails. Use the platform entrance.

All platform occupants **MUST** wear and use fall restraint. Attach fall restraints to the platform lanyard anchor points.

Do not exceed the unrestricted platform capacity as indicated on the capacity placard at the entrance to the platform. Do not carry loads from any point outside of the platform.

Make sure that all protective guards, cowlings, and doors are in place and secure. Be sure the guard-rail system, including the gate, is in place and secure.

Do not climb on the guardrails or use ladders, planks, or other devices to extend or increase your work position from the platform.

Do not use the MHP as a crane, hoist, or jack, or for any other purpose other than to position personnel, their tools, and materials.

Do not operate the MHP15/44 in winds, or wind gusts, of 28 mph, 45kph 12.5 m/s) or more and do not add anything to the MHP15/44 that will increase the wind loading (banners, flags, etc.).

■ General Safety Precautions

Do not modify the MHP15/44 in any way.

When parts or components are replaced, they shall be identical or equivalent to original Snorkel parts or components.

Do not override any of the safety features of the MHP15/44.

■ Hydraulic System Precautions

The hydraulic system contains hoses with hydraulic fluid under pressure.

▲ DANGER

Hydraulic fluid escaping under pressure can have enough force to inject fluid into the flesh. Serious infection or reaction can result if medical treatment is not given immediately. In case of injury by escaping hydraulic fluid, seek medical attention at once.

DO NOT place your hand or any part of your body in front of escaping hydraulic fluid. Use a piece of cardboard or wood to search for hydraulic leaks.

Do not attempt repairs to hydraulic systems unless you are trained. Refer to experienced repair personnel for help.

■ Fire Prevention

Never operate your MHP near a flame or spark. Hydraulic oil and gasoline are flammable and can explode.

NOTE:

This machine is equipped with an internal combustion engine (in its standard configuration) and should not be used on or near any unimproved forest-covered, brush-covered or grass covered land unless the engine's exhaust system is equipped with a spark arrester meeting applicable laws. If a spark arrester is used, it should be

1. Safety

maintained in effective working order by the operator.

■ Engine and Fuel Handling Precautions

⚠ DANGER

Engine exhaust contains carbon monoxide, a poisonous gas that is invisible and odorless. Breathing engine exhaust fumes can cause death or serious illness. Do not run the engine in an enclosed area or indoors without adequate ventilation.

Only refuel your MHP outdoors in a clear area void of gas fumes or spilled gas.

Never remove the fuel cap or refuel a gasoline engine while the engine is running or hot. ALWAYS allow the engine to cool before refueling. Never allow fuel to spill on hot machine components.

⚠ DANGER

DO NOT smoke or permit open flames while fueling or near fueling operations.

Maintain control of the fuel filler nozzle when filling the tank.

⚠ CAUTION

ENSURE you use an approved fuel container with appropriate fuel filler nozzle (see picture below)



Correct Method to Fill MHP15/44 Fuel Tank

Do not fill the fuel tank to capacity. Allow room for expansion.

If gasoline is spilled, clean up spilled fuel immediately, push/tow the MHP away from the

area of the spill and avoid creating any source of ignition until the spilled fuel has evaporated.

Tighten the fuel tank cap securely. If the fuel cap is lost, replace it with an approved cap from Snorkel. Use of a non-approved cap without proper venting may result in pressurization of the tank.

Never use fuel for cleaning purposes.

For diesel engines, use the correct fuel grade for the operating season.

■ Batteries

Charge batteries in a well ventilated area free of flame, sparks, or other hazards that might cause fire or explosion.

⚠ WARNING

Batteries give off hydrogen and oxygen that can combine explosively. Death or serious injury can result from a chemical explosion. Do not smoke or permit open flames or sparks when checking batteries.

Battery acid can damage the skin and eyes. Serious infection or reaction can result if medical treatment is not given immediately. Wear face and eye protection when working near batteries.

Batteries contain sulfuric acid that can damage your eyes or skin on contact. Wear a face shield, rubber gloves, and protective clothing when working around batteries. If acid contacts your eyes, flush immediately with clear water and get medical attention. If acid contacts your skin, wash off immediately with clear water.

■ Safety Decals and Placards

There are several safety decals and placards on the MHP15/44. Their locations and descriptions are shown in this section. Take time to study them.

⚠ CAUTION

Be sure that all the safety decals and placards on the MHP15/44 are legible. Clean or replace them if you cannot read the words or see the pictures. Clean with soap & water and a soft cloth. Do not use solvents.

You MUST replace a decal or placard if it is damaged, missing, or cannot be read. If it is on a part that is replaced, make sure a new decal or placard is installed on the replaced part. See your Snorkel dealer for new decals and placards.

⚠ DANGER

YOU MUST NOT OPERATE THIS DEVICE UNLESS:

1. YOU HAVE BEEN TRAINED IN THE SAFE OPERATION OF THIS DEVICE AND
2. YOU KNOW AND FOLLOW THE SAFETY AND OPERATING RECOMMENDATIONS CONTAINED IN THE MANUFACTURER'S MANUALS, YOUR EMPLOYER'S WORK RULES, AND APPLICABLE GOVERNMENTAL REGULATIONS.

AN UNTRAINED OPERATOR SUBJECTS HIMSELF AND OTHERS TO DEATH OR SERIOUS INJURY.

0323897

⚠ DANGER

ELECTROCUTION HAZARD

THIS MACHINE IS NOT ELECTRICALLY INSULATED.

- Death or serious injury can result from contact or inadequate clearance to electrical power lines and apparatus.
- Maintain 10 feet minimum clearance from electrical power lines and apparatus.
- Allow for sway, rock, and sag.

0323899

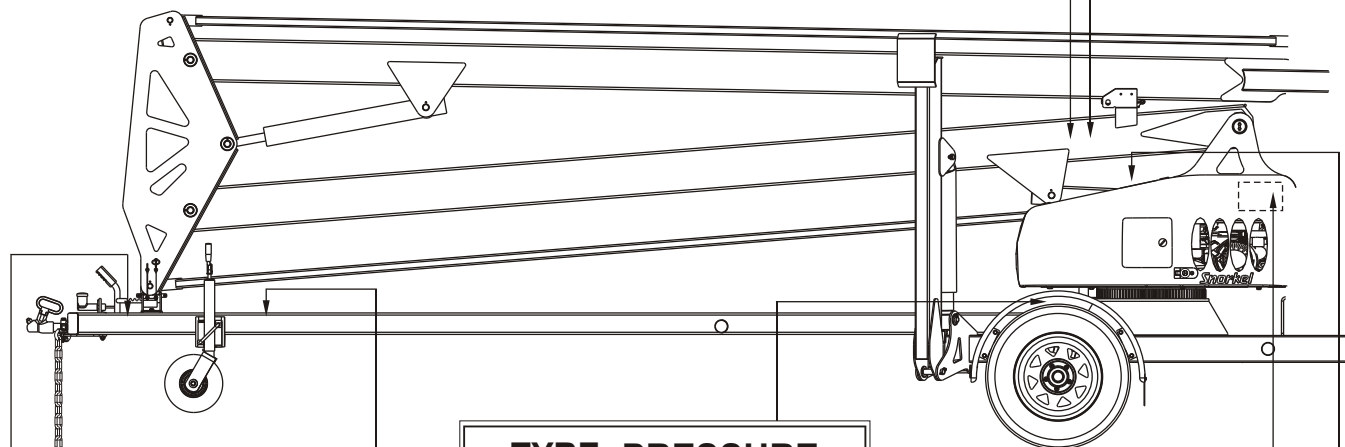

⚠ DANGER

PINCH POINT
Keep hands clear.

TYRE PRESSURE

60 p.s.i. 413 kPa COLD

7856

FIT BOOM CRADLE LOCK PIN FOR TRAVELLING.

1772-002K

⚠ DANGER

EXPLOSIVE FUMES

Death or serious injury might result from fire or explosion.

- Do not smoke or permit open flames while fueling or near fueling operations.
- Clean up spilled fuel immediately.

476706

⚠ DANGER

PINCH POINT
Keep hands clear.

1. Safety

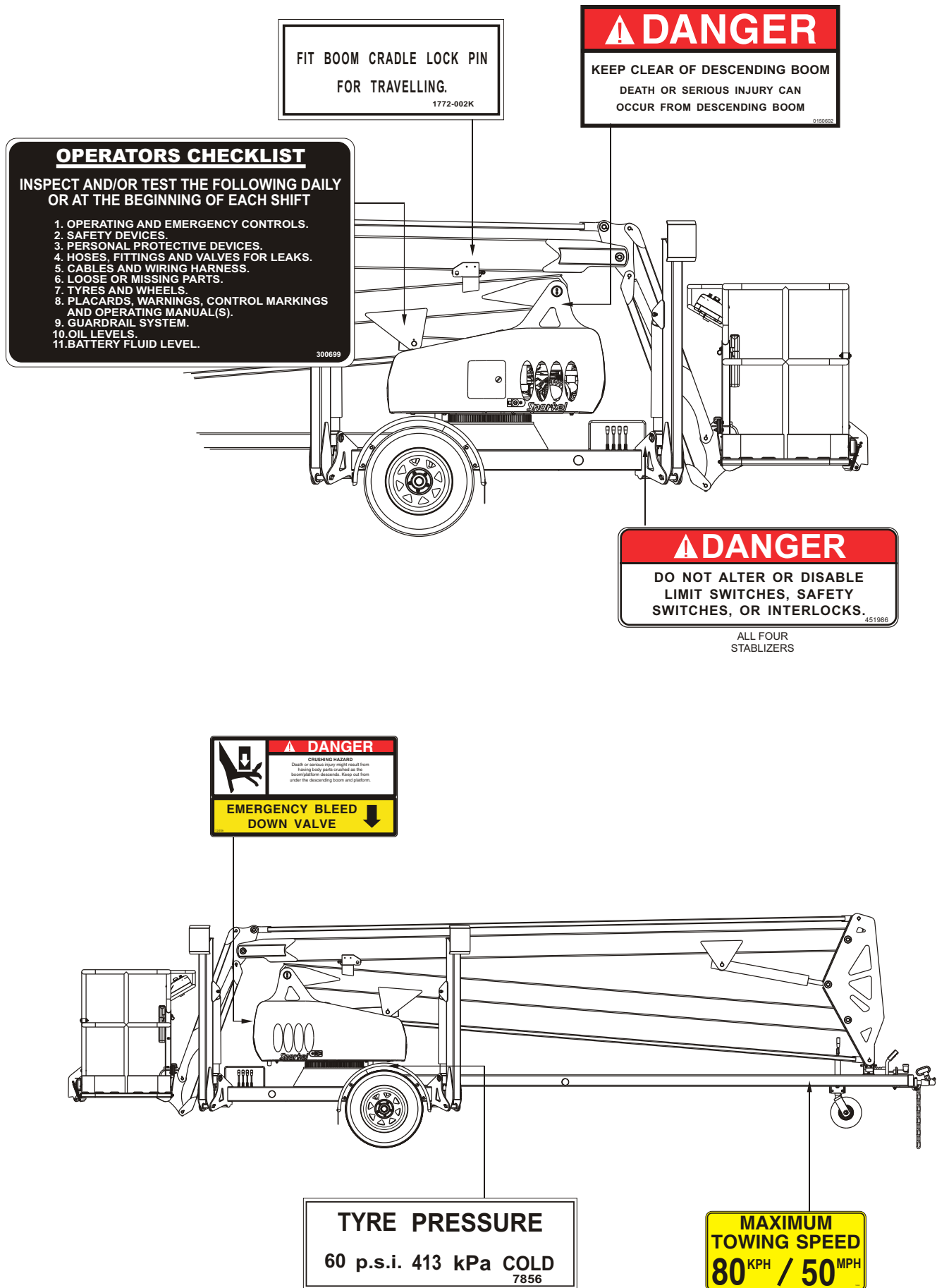

Note: Rated capacity depends on the configuration of the machine
see Chapter 3 - Specifications

RATED LOAD
440^{LB} / 200^{KG}

RATED LOAD
500^{LB} / 227^{KG}

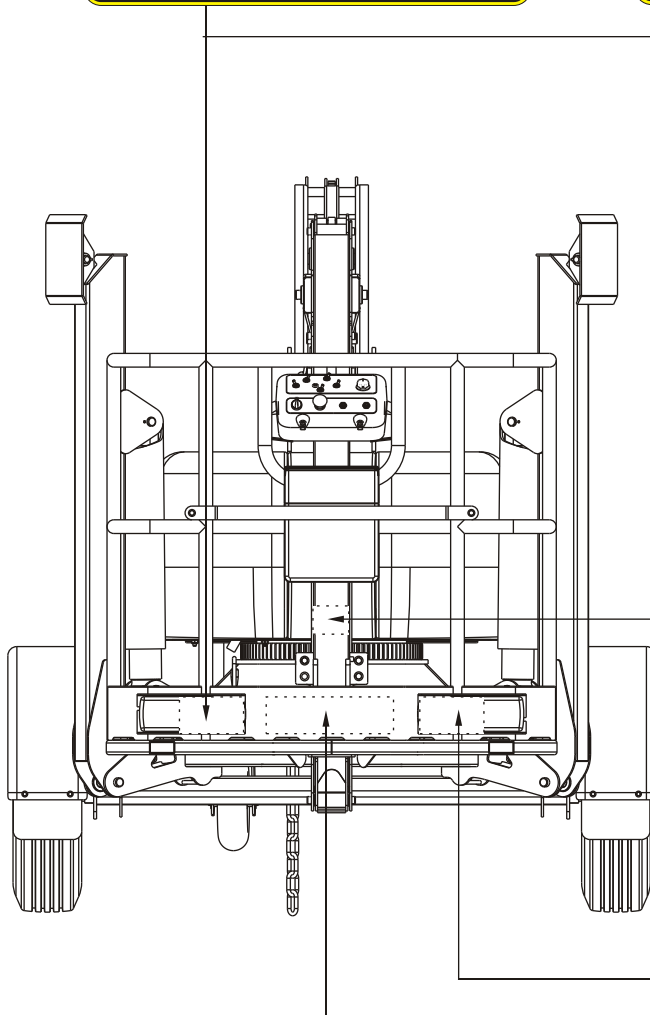

Attach lanyard
of fall restraint
to loop below
0150448

DANGER
BEWARE OF ELECTRICAL HAZARDS
REGULATION 133A OF THE
CONSTRUCTION SAFETY ACT 1912 REQUIRES

- (a) Minimum approach of an appliance to live electrical apparatus. — 3m. for voltages up to 132,000
- (b) Inspection of the work site for electrical hazards before commencing to use the appliance. — 6m. for voltages above 132,000 and up to 330,000
- (c) Constant vigilance and an observer required whilst working or travelling the appliance in the vicinity of live electrical apparatus. — 8m. for voltages above 330,000

(Australia Only)

CAUTION
EACH PERSON ON THE PLATFORM
MUST WEAR A FULL SAFETY HARNESS
WITH LEG STRAPS
AND ENERGY ABSORBING LANYARD
ATTACHED TO AN APPROVED ANCHOR
POINT IN THE PLATFORM
99228-1

WARNING
KEEP CLEAR OF POWER LINES
Unless the Electrical Supply Authority has advised in writing otherwise;
the clearance between any live overhead power line and any part of this machine or load carried is required by law to be
AT LEAST 4 METRES
This is a requirement of regulation 93 of the Electrical Supply Regulations 1984 in the interests of safe working.

(New Zealand Only)

NOTE:

Refer to Placards and Decals Inspection Chart and Drawing in the “Daily Inspection and Maintenance” chapter 7, for part numbers, location, and required quantities of all placards and decals.

■ Safety Device Information

For emergency operation controls and procedures, see the “Emergency Operation” chapter 9, in this manual.

The devices listed in this chapter are safety devices.

They are on the MHP15/44 to increase safety in the work place for both the operator and other people near the MHP15/44.

▲ WARNING

DO NOT by pass, disable, modify, or ignore any of these devices. Check them carefully at the start of each work shift to see that they are in working order (see “Daily Inspection and Maintenance” chapter 7). If any is found to be defective, remove the MHP15/44 from service immediately until a qualified service technician can make repairs.

■ Emergency Stop Switches

□ At ground control box



Figure 2.1 - Emergency Stop Switch at Ground Control Box

Press the large red **EMERGENCY STOP** switch in, at any time, under any conditions and the entire machine stops, and nothing moves. This emergency stop switch must be out (on) for anything on the MHP15/44 to work (pull the switch and it will pop out).

□ At platform control box

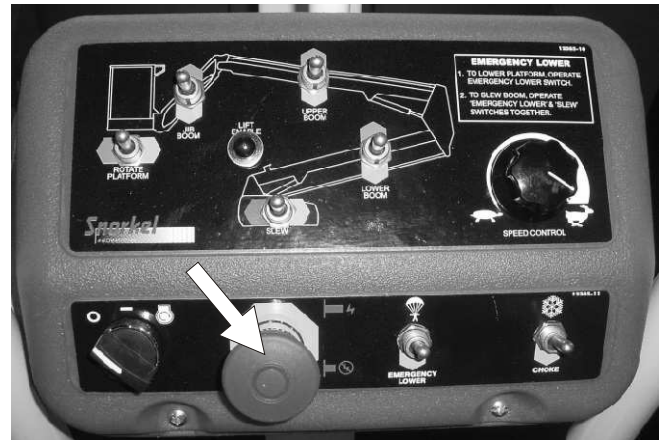

Figure 2.2 - Emergency Stop Switch at Platform Control Box

Press the large red **EMERGENCY STOP** switch in, at any time, under any conditions and the entire machine stops, and nothing moves. This emergency stop switch must be out (on) to control the MHP15/44 from the platform (pull the switch and it will pop out).

NOTE:

The ground control box is designed to override the platform control box. If the platform control box **EMERGENCY STOP** switch is in (off) the ground control box can still be used to start and operate the MHP15/44.

■ Other Safety Devices

□ Lanyard anchor points



Figure 2.3 - Lanyard Anchor Points

All personnel on the platform should attach their fall restraint lanyards to one of the lanyard anchor points.

2. Safety Devices

Gravity gate

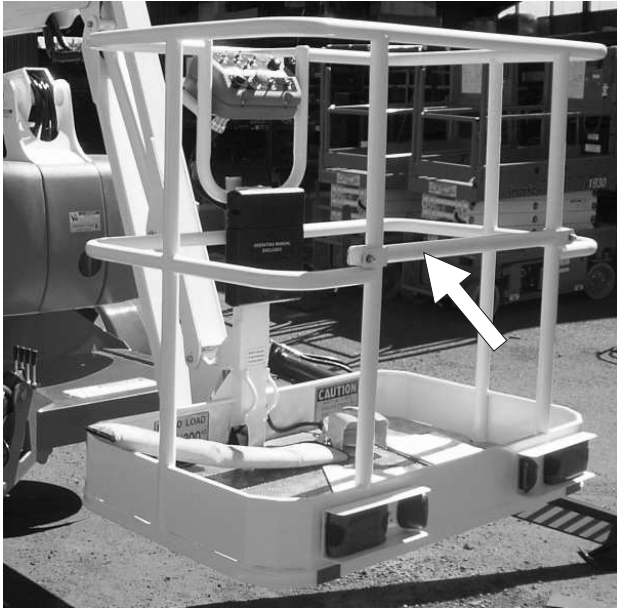

Figure 2.4 - Gravity Gate

The gravity gate is the place in the platform guard-rail system where you should enter and leave the platform. Raise the gate and step under it onto the platform. Once you have entered the platform and attached your fall restraint lanyard to an anchor point, check to see that the gravity gate has fallen back into place.

Guardrails

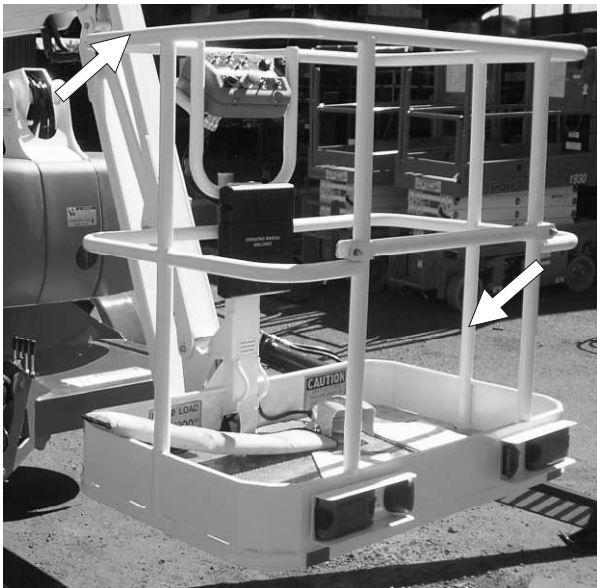

Figure 2.5 - Guardrails

The guardrails help protect you from falling off the platform. Be sure the guardrails are properly installed and that the gravity gate or swinging gate is in place.

Foot switch



Figure 2.6 - Foot Switch

The foot switch prevents the platform from moving if something accidentally pushes one of the platform-moving controls on the platform control box. Stepping on the foot switch is an action that must be performed, at the same time as another action, to make the platform move.

Bubble level

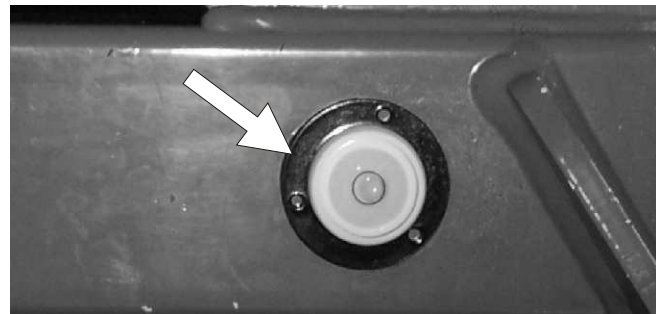

Figure 2.7 - Bubble Level

A bubble level is located on the trailer side rail, in front of the outrigger controls. Watch the bubble level while you set the outriggers. Lower the outriggers, one at a time, just enough to center the bubble in the circle on top of the gauge. When the bubble is centered the platform is level and can be safely raised.

❑ RCD/ELCB AC outlet

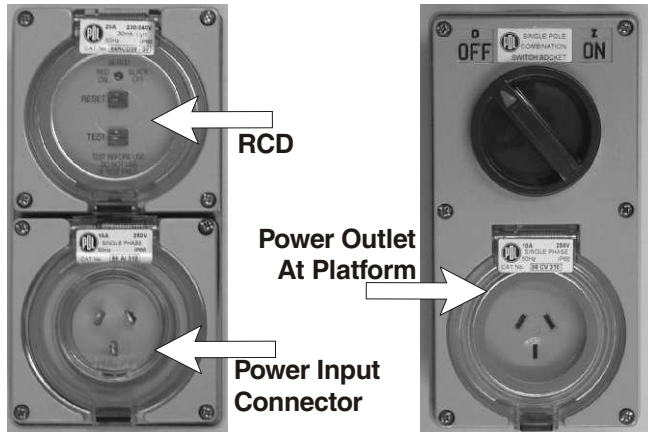

Figure 2.8 - RCD/ELCB AC Outlet

The RCD (Residual Current Device) is located at the base and will protect against short circuits to earth. When there is a short circuit the RCD will shut down the 230v AC power to the platform outlet.

To reset the outlet disconnect the power tool lead from the platform box and reset the RCD at the base.

If the problem persists call a trained service technician.

❑ Flashing light

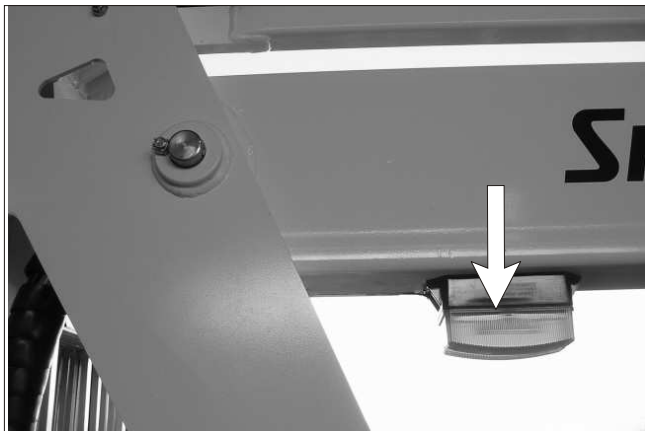

Figure 2.9 - Flashing Light

The flashing light alerts people that the MHP15/44 is moving. The light flashes at about one flash per second any time the MASTER KEY switch is on. There is no ON/OFF switch for the flashing light, it cannot be turned off while the MHP15/44 is running.

2. Safety Devices

3. Specifications

The Snorkel MHP15/44 is a boom supported elevating work platform built to conform to these standards, American Standard ANSI A92.2-2001, Australian Standard AS1418-10(Int) 2004 Elevating Work Platforms.

NOTE:

For further details regarding lubricants, maintenance schedules and service please refer to the Maintenance and Repair Parts Manual for this machine.

■ **General Specifications**

SPECIFICATIONS	MHP15/44	
Working height	15.4m	50'
Platform height	13.4m	44'
Rated load	227kg	500lb
Rated load (with rotator)	200kg	440lb
Platform size	1.2 x 0.7 x 1.14m	4' x 2' 6" x 3' 7"
Platform construction	Steel	
Platform levelling	Mechanical	
Boom type	Articulating	
Horizontal reach	6.45m at 8m	21' 1" at 26' 3"
Maximum wind speed 12.5m/s	45kph	28mph
Turntable rotation	540° non-continuous or 360° continuous	
Power source (std.)	Gasoline engine 5.5hp	
Hydraulic system	Proportional electro/hydraulic	
Stabilisation	4 independently operated hydraulic outriggers with safety interlocks	
Stabiliser footprint (max.)	3.7 x 3.6m	12' 1" x 13' 9"
Standard colour	Snorkel orange base and covers, white turret and booms	
Transport height	2.1m	6' 10"
Overall length	7.45m	24' 5"
Overall width - outriggers extended	3.95m	13'
Overall width - outriggers stowed	1.77m	5' 9"
Tyre size	185 x R15C	
Brakes	Hydraulic disc	
Maximum towing speed	80kph	50mph
Maximum rated axle capacity	2000kg	4409lb
Weight (standard model)	1500kg	3306lb
Insulation rating	Nil	
Trailer tongue weight	90kg	198lb

3. Specifications

■ Engine Data

Engine Make	Honda (gasoline)
Model	GX 160
Engine type	4-stroke, over head valve, 1 cylinder
Displacement	163 cm ³ (9.9 cu-in)
Bore x Stroke	68 x 45 mm (2.7 x 1.8 in)
Max. output	4 kW/4,000 rpm
Max. torque	1.1 kg-m (8.0 ft-lb)/ 2500 rpm
Fuel	gasoline
Fuel Grade	automotive gasoline (unleaded or lowleaded preferred)
Fuel consumption	230 g/PSh
Cooling system	Forced air
Ignition system	Transistor magneto
PTO shaft rotation	Counterclockwise
Oil Capacity	0.60 litres (0.60 US qt, 0.53 Imp qt)
Oil Grade	SAE 10W-30

■ Recommended Hydraulic Oil

Shell Tellus 32 or Castrol AWS 32 or similar

■ Overall Dimensions - MPH15/44

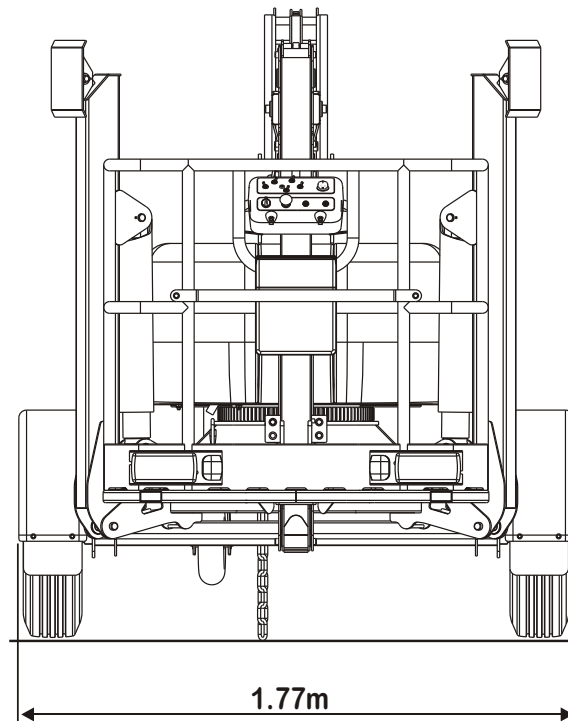
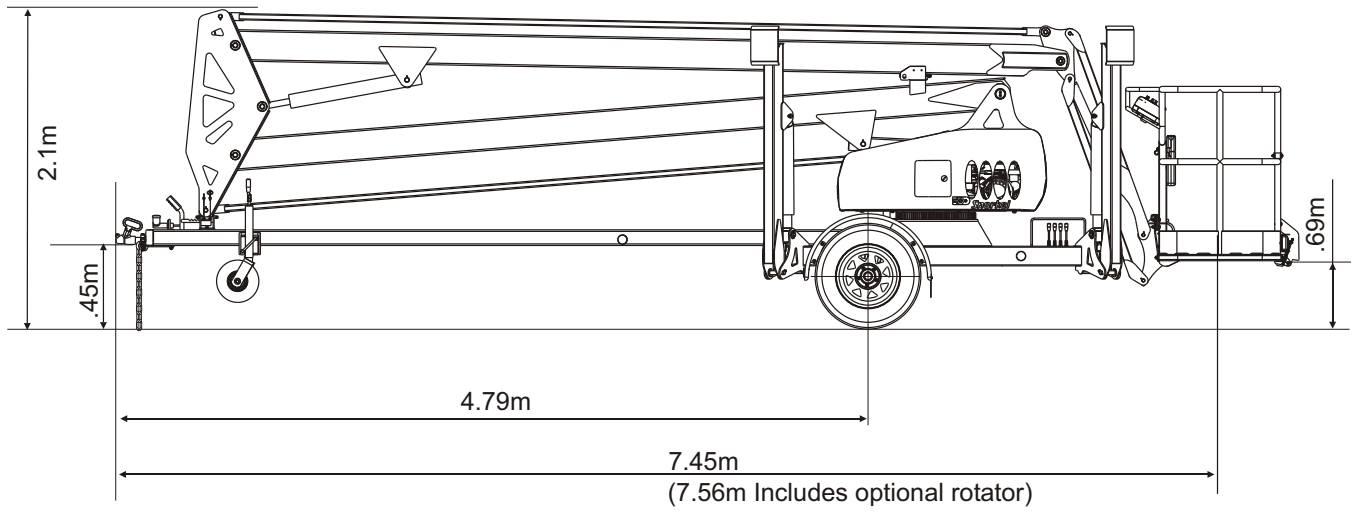

3. Specifications

■ Working Envelope - MHP15/44

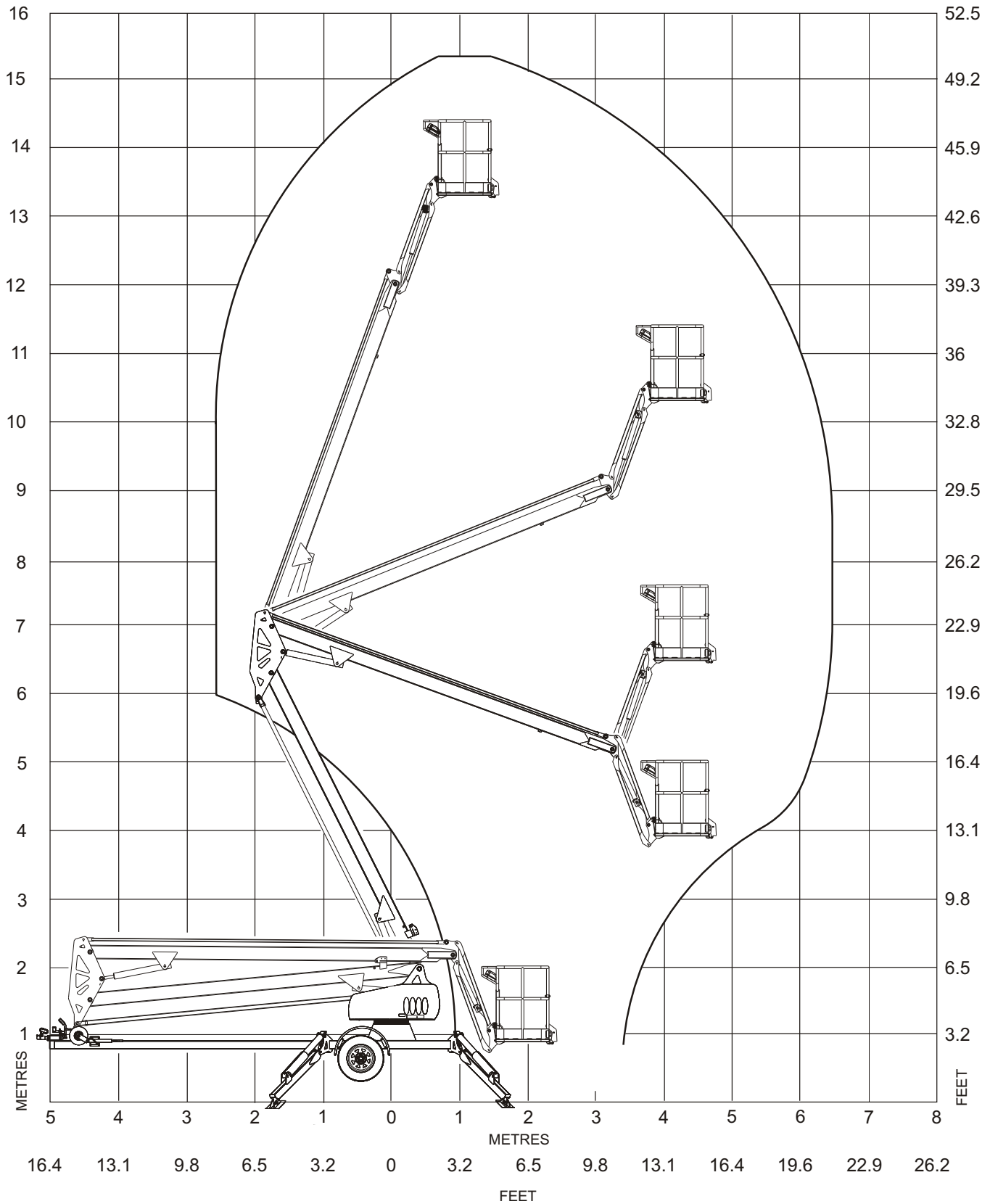

■ Nomenclature And Serial Numbers

□ Right side view of machine

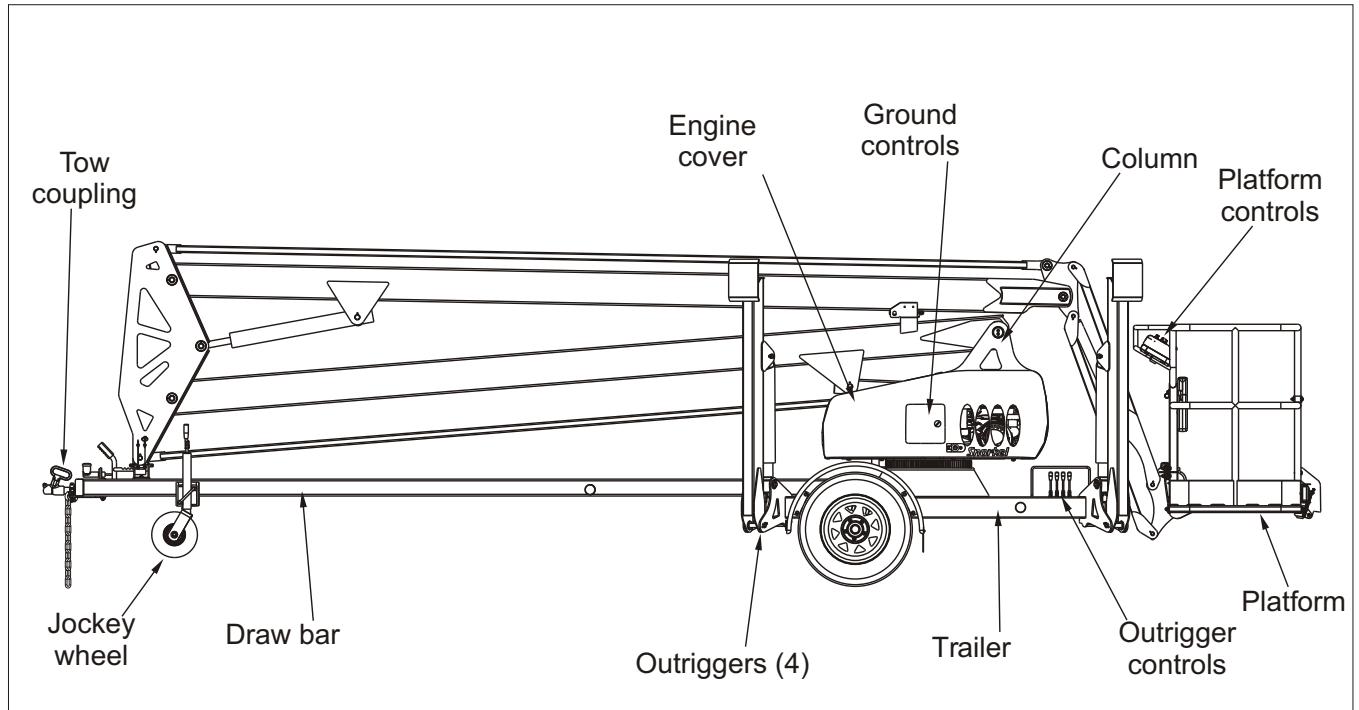

□ Booms identification

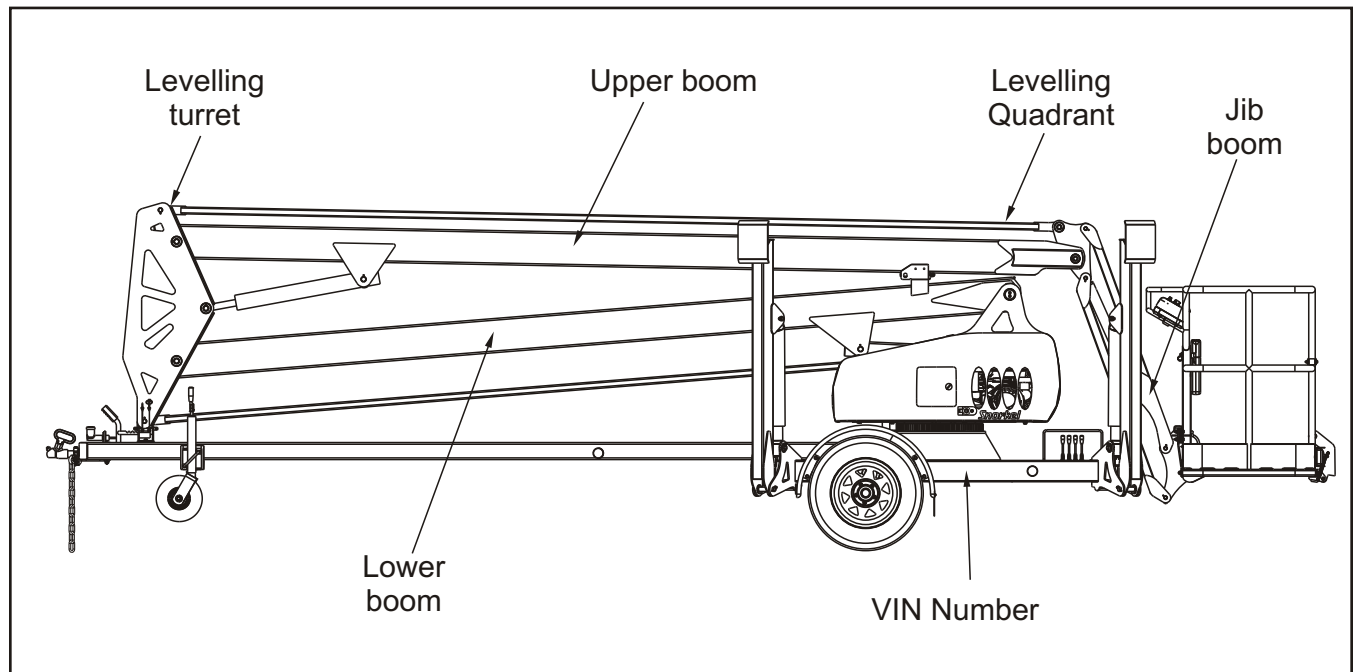

3. Specifications

☐ Left side view of machine

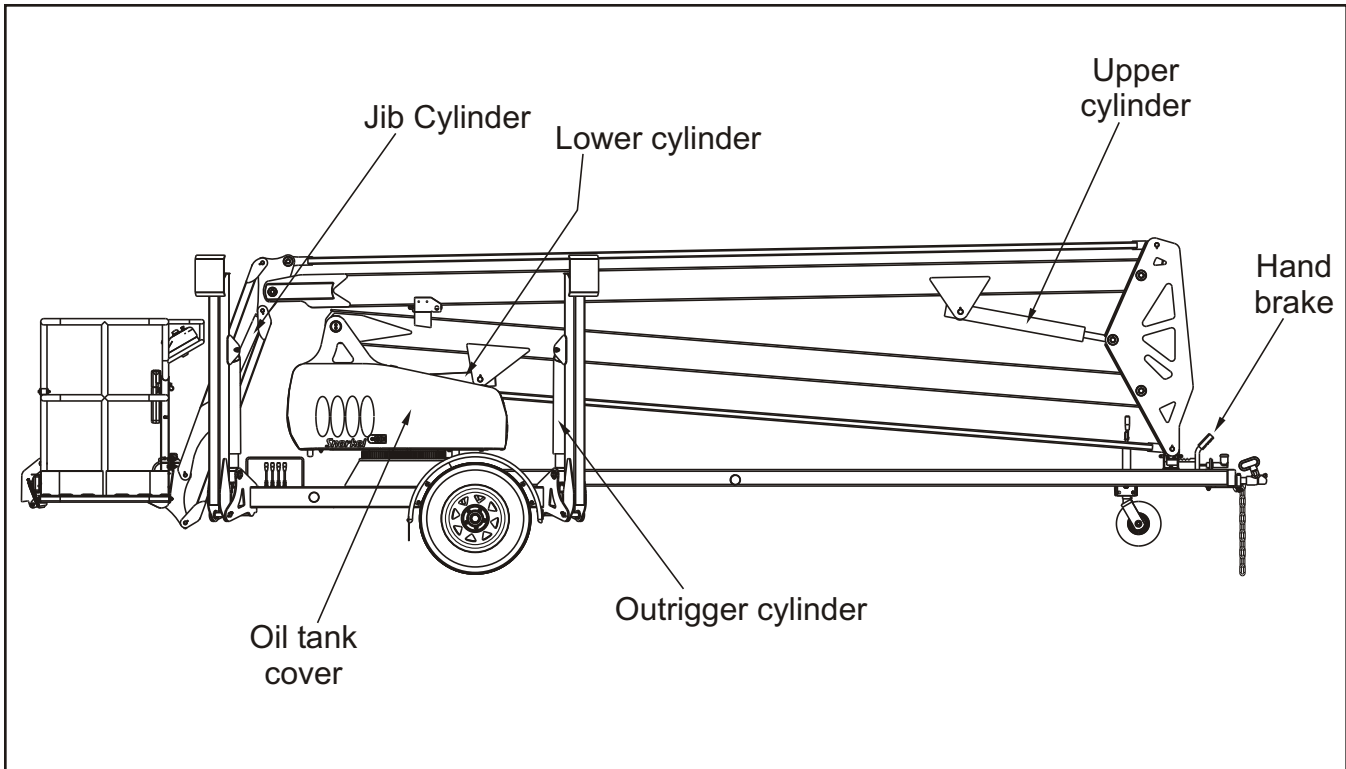

■ Hourmeter

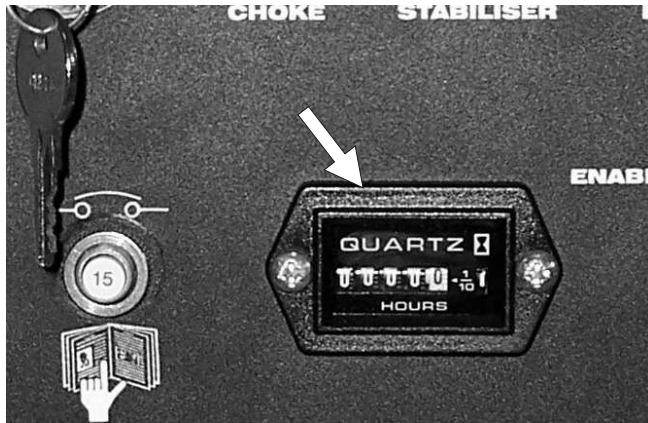

Figure 4.1 - Hourmeter

The hour meter is basically an electric clock. It accumulates time when the master key switch is turned on. The hour meter cannot be reset. An MHP qualified service technician can use it to tell when it is time for the periodic maintenance listed in the maintenance manual.

■ Level Bubble

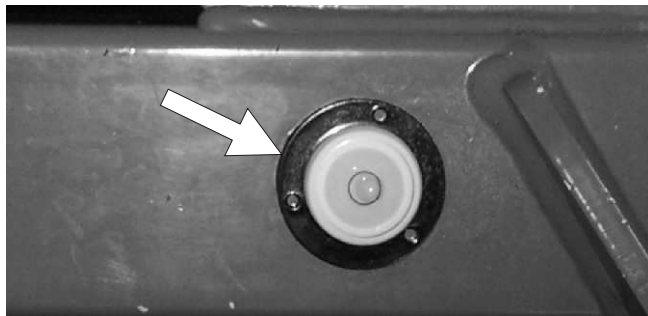

Figure 4.2 - Level Bubble

A level bubble is located in front of the outrigger control valve, mounted on the trailer base. Watch the bubble while you set the outriggers. Lower the outriggers, front ones first, one at a time just enough to center the bubble in the circle on top of the gauge. When the bubble is central the platform is level and the platform can be safely raised.

■ Hydraulic Oil Level



Figure 4.3 - Hydraulic Oil Level

The hydraulic oil level gauge is on the side of the hydraulic oil tank. It shows the actual level of oil inside the tank. Read it only when the booms are fully lowered and outriggers are raised in the travel position. The oil level should be within + or - 6mm (1/4") of the line.

4. Gauges

■ RCD/ELCB Outlet (option)

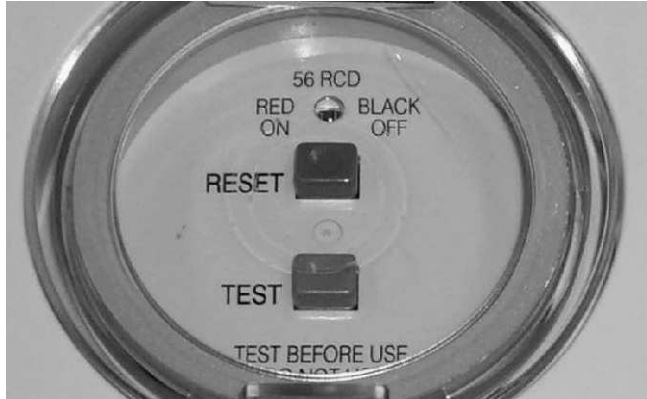

Figure 5.1 - RED/ELCB Outlet

The RCD (Residual Current Device) is located at the base and will protect against short circuits to earth. When there is a short circuit the RCD will shut down the 230v AC power to the platform outlet.

To reset the outlet disconnect the power tool lead from the platform box and reset the RCD at the base.

If the problem persists call a trained service technician.

■ Main Circuit Breaker



Figure 5.2 - Main Circuit Breaker

There is only one circuit breaker, on a standard MHP15/44, that is accessible to the operator. Its purpose is to protect the electrical circuits from electrical overloads. When the circuit breaker trips (pops out) push it back in then attempt to use the MHP15/44. If the circuit breaker trips a second time, take the MHP15/44 out of service and refer the problem to a qualified trained service technician for repair.

■ Outriggers

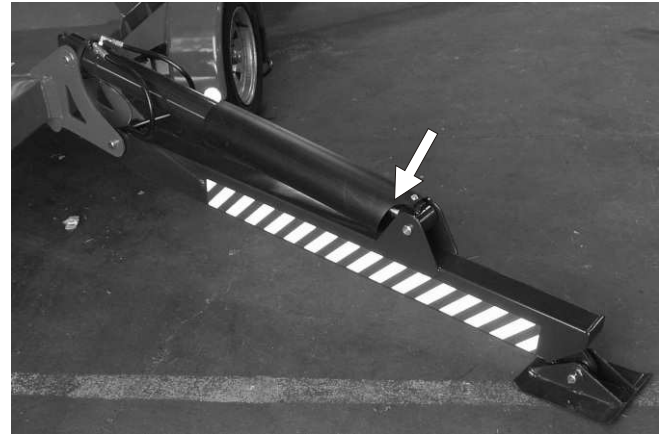

Figure 5.3 - Outriggers

The MHP15/44 booms cannot be raised unless the outriggers are set and the lift enable light on the lower control box is lit. Once the booms are raised from the stowed position the outriggers become disabled until the booms are stowed in the travel position.

5. Automatic Shut-offs and Circuit Breakers

■ Controls Description

This chapter explains what each control does.

This chapter **DOES NOT** explain how to use the controls to produce useful work, refer to the “Operation” chapter 8-1 for that after you have read this chapter.

For optional equipment controls, see the “Options” chapter.11-1

See the “Emergency Operation” chapter 9-1 for the location of the emergency bleed down control and for correct emergency bleed down procedures.

The main operating functions of an MHP15/44 can be controlled from the ground control box or from the platform control box.

▲ DANGER

Pinch points may exist between moving components. Death or serious injury can result from becoming trapped between components, buildings, structures, or other obstacles. Make sure all personnel stand clear while operating the MHP.

□ Controls and Control Decals Locations

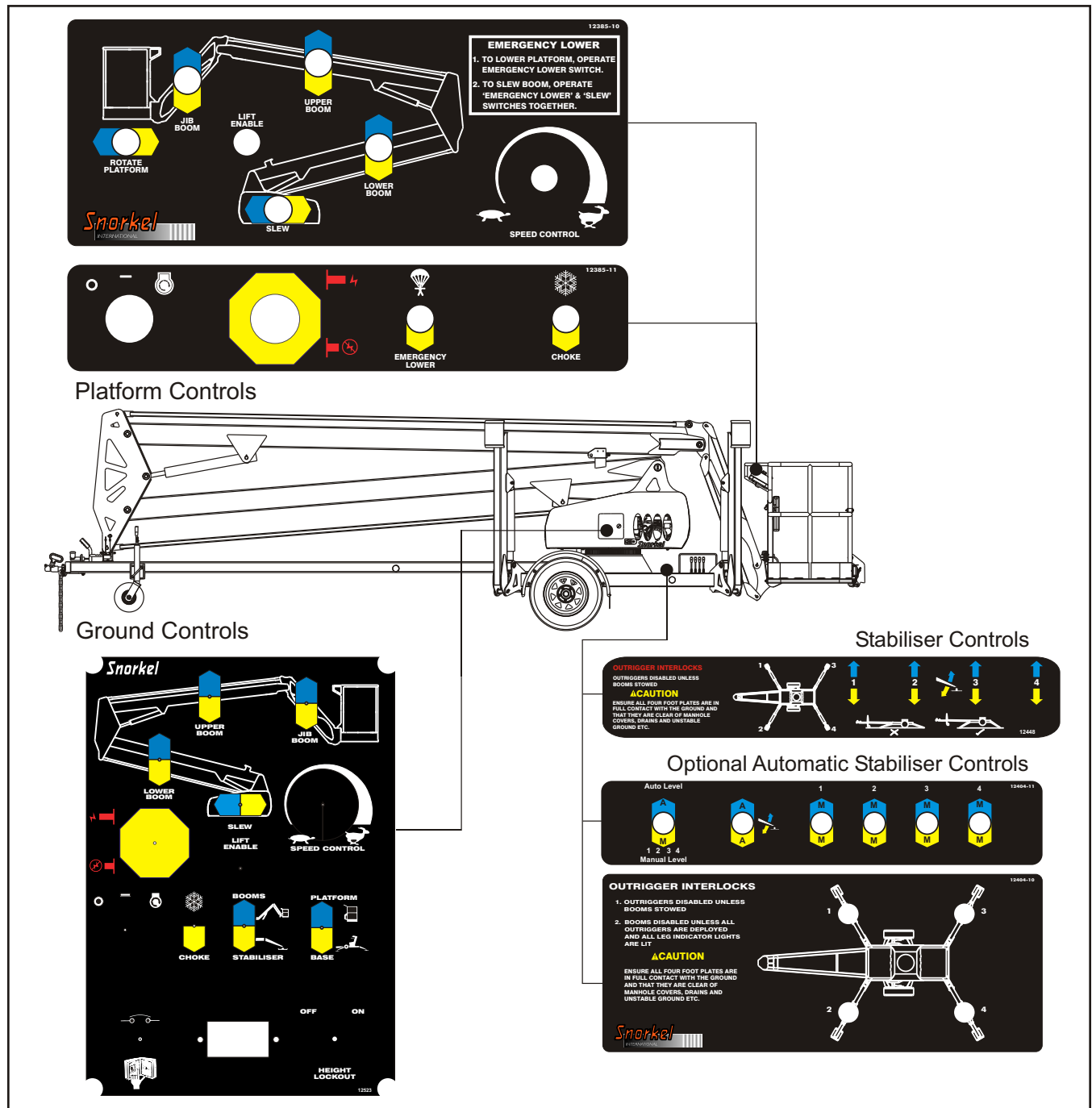

6. Controls

■ Ground Control Box

Controls for operating the MHP15/44 from the ground, (lower controls) are located on the right side of the turntable.

□ Lower controls:

- Emergency stop switch
 - Platform/ground selector switch
 - Choke
 - Master key switch
 - Boom speed switch
 - Stabiliser/boom selector switch
 - Lower boom switch
 - Upper boom switch
 - Jib boom switch
 - Slew switch
 - Lift enable indicator
 - 10.9 metre lockout switch
1. **Emergency Stop:** Press the red EMERGENCY STOP button in, at any time, under any conditions, and the entire machine stops, and nothing moves. This switch must be out (on) for anything on the MHP15/44 to work. Pull the switch and it will pop out (on).
 2. **Platform/Ground Selector :** Must be in the GROUND position (down) for the ground control box to work. The switch MUST be in the PLATFORM position (up) for the platform control box to work.
 3. **Choke/Cold Start:** Hold the switch UP while you start an engine that is at ambient air temperature (a "cold" engine). This will choke the engine.
 4. **Master Key Switch:** This switch works like an automobile ignition switch. Hold it at START until the engine starts, then release it to ON. (-) Turn the **Master Key Switch** to OFF (O) if the platform is to stay in one position for a long time, that will turn the engine off and save fuel.
 5. **Boom Speed:** This control determines how fast the booms move. Set it to SLOW (turtle) until you are very familiar with the way the machine works or if the platform is working in dangerous or cramped surroundings.
 6. **Stablizer / Boom Selector Switch:** Must be in Stablizer (outrigger) position (down) for the outriggers to work. Once outriggers are down and set the switch must be placed in the boom (up) position for the booms to work.

Control switches 7 through 10 are the platform moving switches. Each is a three position, momentary contact, normally OFF switch.

7. **Lower Boom :** UP raises the lower boom. DOWN lowers the lower boom.
8. **Upper Boom:** UP raises the upper boom. DOWN lowers the upper boom.
9. **Jib Boom:** UP raises the jib boom. DOWN lowers the jib boom.
10. **Slew:** LEFT rotates the entire turntable and boom to the left. RIGHT rotates the entire turntable and boom to the right.
11. **Lift Enable:** The platform can only be raised when this light is lit. When this light is not lit the platform will not raise because the outriggers are not properly set.
12. **10.9 Metre Lockout Switch:** Where fitted, this switch restricts the platform to a maximum of 10.9 metres in height.

□ Ground Control Box Controls

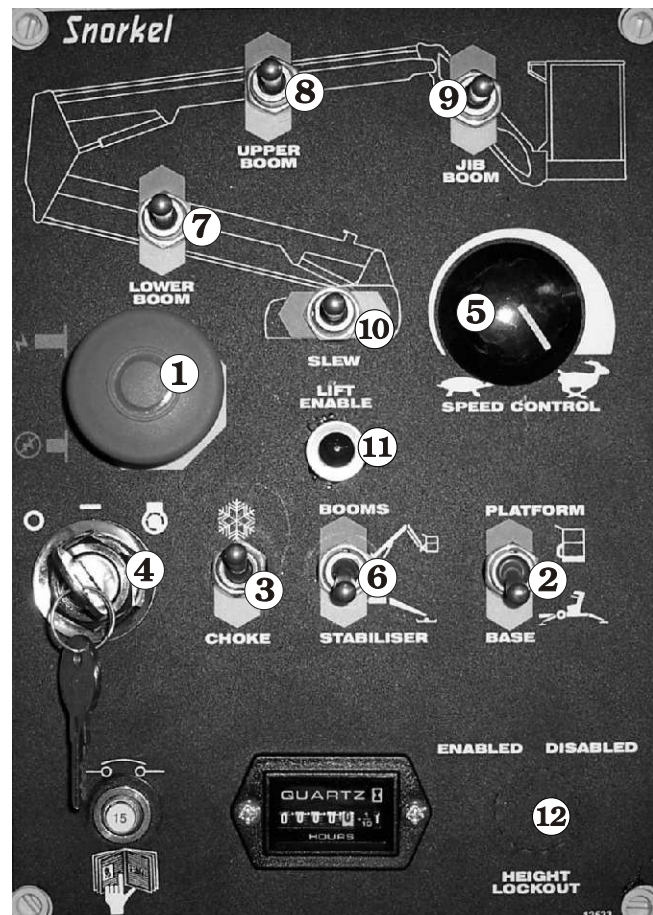

Lower Control Box Controls

■ Platform Control Box

Controls for operating the MHP15/44 from the platform (upper controls) are located on the platform control box, with the exception of the foot switch which is on the platform floor.

□ Upper controls:

- Emergency stop switch
 - Choke
 - Start switch
 - Boom speed switch
 - Emergency lower switch
 - Platform rotate switch
 - Lower boom switch
 - Upper boom switch
 - Jib boom switch
 - Slew switch
 - Lift enable indicator
 - Foot switch
1. **Emergency Stop:** Press the red EMERGENCY STOP button in, at any time, under any conditions, and the entire machine stops, and nothing moves. This switch must be out (on) to start or run the MHP from the platform control box. Pull the switch and it will pop out (on). Press the switch in (off) if the platform is to stay in one position for a long time. That will turn the engine off and save fuel.
 2. **Choke/Cold Start:** Hold the switch UP while you start an engine that is at ambient air temperature (a "cold" engine). This will choke the engine.
 3. **Start:** This switch works like an automobile ignition switch. Hold it at START until the engine starts, then release it to ON (-). If the engine dies in ON, the key must be turned to OFF (O) before it will go back to START. Turn the switch to OFF if the platform is to stay in one position for a long time, that will turn the engine off and save fuel.
 4. **Boom Speed:** This control determines how fast the booms move. Set it to SLOW (turtle) until you are very familiar with the way the machine works or if the platform is working in dangerous or cramped surroundings.
 5. **Emergency Lower:** If the engine stops and cannot be restarted, hold the switch down and this will lower the upper and lower booms (not the jib boom). To slew during emergency lower operate emergency lower and slew switches together.

Items 6 through 10 are the platform moving switches. Each is a three position, momentary contact, normally OFF switch.

6. **Platform Rotate:** (Option) LEFT rotates the platform left. RIGHT rotates the platform right.
7. **Lower Boom:** UP raises the lower boom. DOWN lowers the lower boom.
8. **Upper Boom:** UP raises the upper boom. DOWN lowers the upper boom.
9. **Jib Boom:** UP raises the jib boom. DOWN lowers the jib boom.
10. **Slew:** LEFT rotates the entire turntable and boom to the left. RIGHT rotates the entire turntable and boom to the right.
- 11 **Lift Enable:** The platform can only be raised when this light is lit. When this light is not lit the platform will not raise because the outriggers are not properly set.

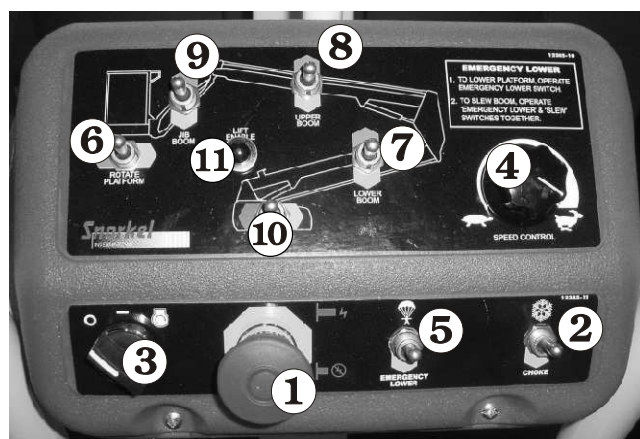

Upper Control Box Controls

12. **Foot Switch:** You must step down on the foot switch, and hold it down when you use any platform control that causes the platform to move.



Upper Controls Foot Switch

6. Controls

■ Stabiliser Controls

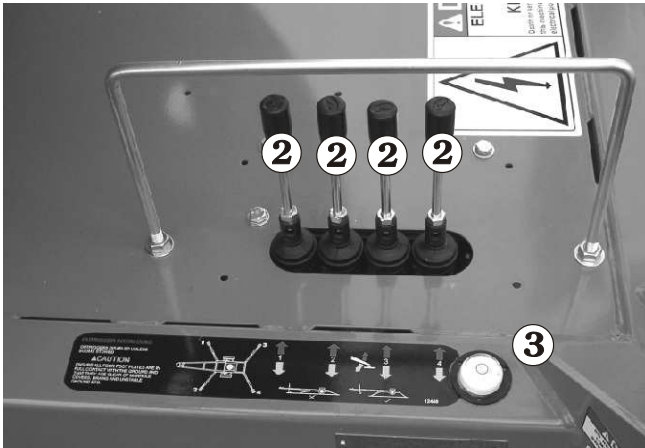

Stabiliser Controls

1. **Boom / Stabiliser Switch:** Ensure the boom/stabiliser switch on the lower control box is set to stabiliser (see Item 6 on page 2 of this chapter)

NOTE:

Ensure that the front stabilisers are lowered first to prevent damage to the jockey wheel.

2. **Valve Levers:** Operate the valve levers to activate the stabilisers and level the machine.
3. **Bubble level:** Use the bubble level to level the machine.

■ Self Levelling Stabilisers (Option)

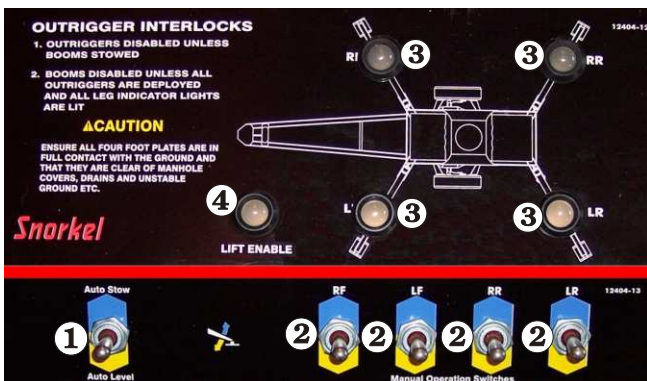

Self levelling Stabiliser Controls

1. **Auto Level / Stow Switch:** Select either auto level or auto stow, to raise or lower the stabilisers automatically.
2. **Manual Stabiliser Switches:** Operate the manual switches to manually raise or lower individual stabilisers.
3. **Leg Indicator Lights:** Illuminate when the legs are in contact with the ground.

4. **Lift Enable Light:** This is a duplicate of the lift enable light on the lower control box. The platform can only be raised when this light is lit. When this light is not lit the platform will not raise because the outriggers are not set properly.

NOTE:

Ensure that the front stabilisers are lowered first to prevent damage to the jockey wheel.

Activate the rear stabilisers and level the machine using the level bubble adjacent to the control levers.

7. Daily Inspection and Maintenance

At the start of each work day (or 8 hour shift), an MHP15/44 qualified operator must perform the Daily Inspection and Maintenance as listed in the table below.

The purpose of the Daily Inspection and Maintenance is to keep the MHP15/44 in proper working condition and to detect signs of malfunction at the earliest possible time.

The MHP15/44 should be in the STOWED POSITION and the **Master Key Switch** set to OFF before you begin this inspection.

Defective parts and/or equipment malfunctions jeopardize the safety of the operator and other personnel, and can cause damage to the machine.

▲WARNING

The potential for an accident increases when operating an MHP that is damaged or malfunctioning. Death or serious injury can result from such accidents. Do not operate an MHP that is damaged or malfunctioning.

■ Daily Inspection and Maintenance Table

Item	Service Required
Engine fuel level	Look to see that the fuel tank is full
Fuel tank cap	Check to see that the cap is tight
Engine oil level	Check oil level (between dipstick lines)
Fuel leaks	Visually inspect (hoses and connections)
Operator's manual	Check that it is in the holder on the machine
Wiring harnesses	Visually inspect (installation, condition)
Battery terminals	Visually inspect (no corrosion)
Battery fluid level	Check fluid level (1/4" or 6 mm below filler neck)
Hydraulic oil level	Visually inspect level (between lines on gauge)
Hydraulic oil leaks	Visually inspect (hoses, tubes)
Tires and wheels	Visually inspect (condition)
Bolts and fasteners	Visually inspect (condition)
Structural damage and welds	Visually inspect (weld cracks, dents)
Lanyard anchor points	Visually inspect (condition)
Platform gravity gate	Check condition and operation
Platform guardrails	Visually inspect (condition)
Flashing light (option)	Visually inspect (operation)
Ground control switches	Actuate and inspect for proper operation
Level sensor (option)	Check operation
Emergency lower	Check operation (causes correct motion)
Platform control box switches	Actuate and inspect for proper operation
RCD/ELCB AC outlet (option)	Check operation
Platform work lights (option)	Check operation
Placards and decals	Visually inspect (installation, condition)

7. Daily Inspection and Maintenance

The rest of this chapter shows how to perform the inspection and maintenance required for each item in the Daily Inspection and Maintenance Table.

■ Engine Fuel Level

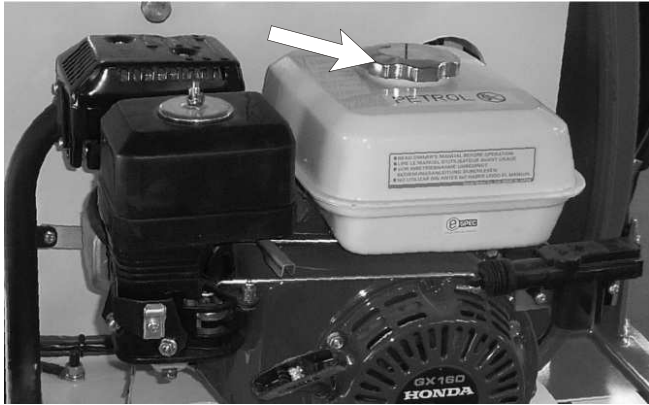

Figure 7.1 - Engine Fuel Level

Visually check to see that the gasoline tank is full. See the “Specifications” chapter 3, fuel for octane and grade.

▲ CAUTION

The handling and use of gasoline presents serious risk of fire and explosion if due care is not exercised. Refer to the refueling instructions in the safety chapter.

■ Fuel Tank Cap



Figure 7.2 - Fuel Tank Cap

Check to see that the tank cap is in place and is tight.

■ Fuel Leaks

Visually inspect the Honda fuel tank and the engine compartment for any signs of leaking/spilt fuel.

■ Engine Oil Level

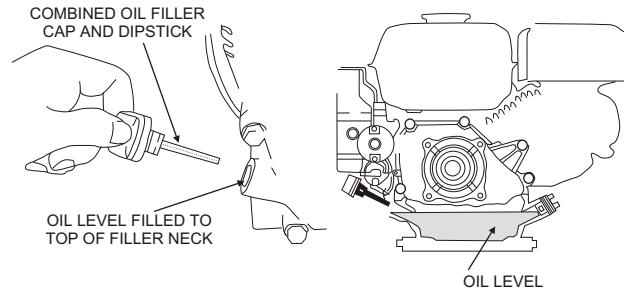

Figure 7.4 - Engine Oil Level

Remove the oil filler cap and wipe the dipstick clean. Insert the dipstick into the oil filler neck, but do not screw it in. If the level is low, fill to the top of the oil filler neck with the recommended oil.

■ Operator's Manual



Figure 7.5 - Operator Manual

Check that the Operator's manual is complete and in the holder on the platform.

■ Wiring Harnesses



Figure 7.6 - Wiring Harnesses

Inspect all the wiring harnesses, on the machine, for loose connections, broken wires, and frayed insulation.

■ Battery Terminals

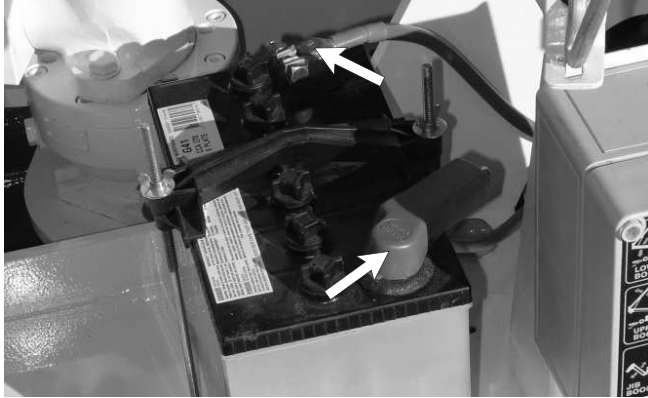

Figure 7.7 - Battery Terminals

Battery terminals should be tight, clean and free of dirt and corrosion.

■ Battery Fluid Level

▲ WARNING

Batteries emit hydrogen and oxygen, elements that can combine explosively. Death or serious injury can result from a chemical explosion.

DO NOT smoke or permit open flames or sparks when checking batteries.

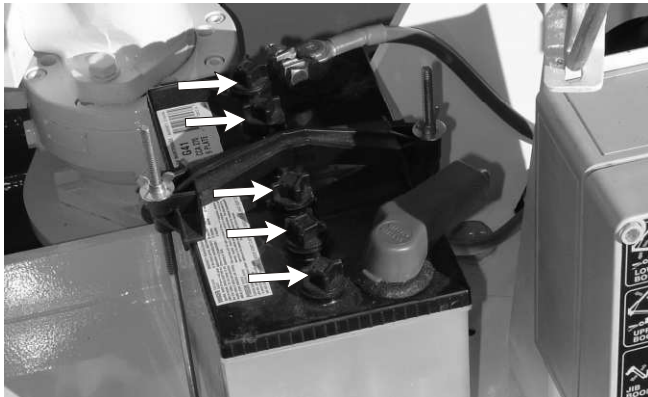

Figure 7.8 - Battery Fluid Level

Remove the caps from the battery and visually check to see that the battery fluid is 1/4" (6 mm) below the bottom of the filler neck inside each hole.

■ Hydraulic Oil Level

To check the hydraulic oil level:

Completely lower the booms and ensure the stabilisers are in the stowed position.



Figure 7.9 - Hydraulic Oil Level

The hydraulic oil level should be between the two marks on the decal.

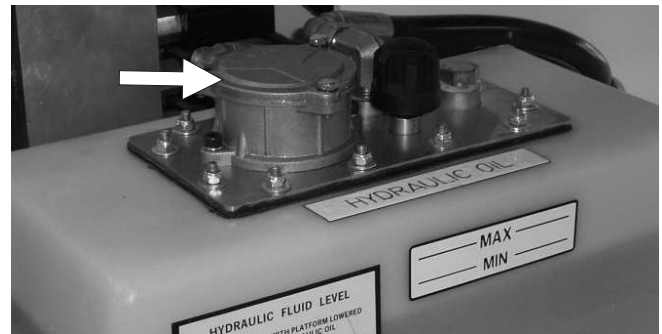

Figure 7.10 - Hydraulic Oil Filler Cap

If necessary, add hydraulic oil at the filler cap. See the "Specifications" chapter 3, for type and grade of hydraulic oil.

■ Hydraulic Oil Leaks

▲ DANGER

Hydraulic fluid escaping under pressure can have enough force to inject fluid into the flesh. Serious infection or reaction can result if medical treatment is not given immediately. In case of injury by escaping hydraulic fluid, seek medical attention at once.

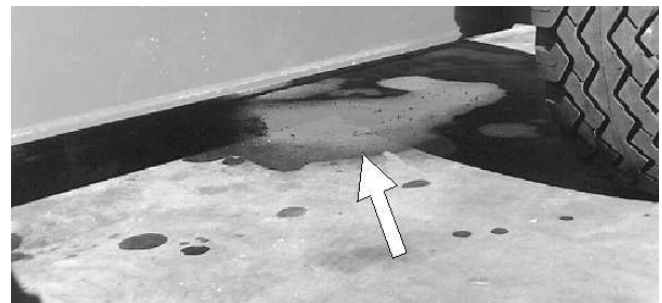

Figure 7.11 - Hydraulic Oil Leaks

7. Daily Inspection and Maintenance

Check the ground under the machine for leaked oil.

Do not search for leaks with your hand, use a piece of cardboard or wood.

Hydraulic oil leaks are easily visible and can show up anywhere. Visually inspect the entire machine for hydraulic oil.

Carefully inspect the ends of the upper and lower booms. Oil can run down inside of the booms and drip out the end.



Figure 7.12 - Hydraulic Oil Leaks At Fittings And Hoses

Inspect all fittings and hoses for leaks. Inspect hoses for signs of damage from chaffing or rubbing against protrusions on the chassis.

Have a qualified trained maintenance person repair all hydraulic fluid leaks before you operate an MHP15/44

■ Bolts and Fasteners

Visually inspect all fasteners to see that none is missing or obviously loose.

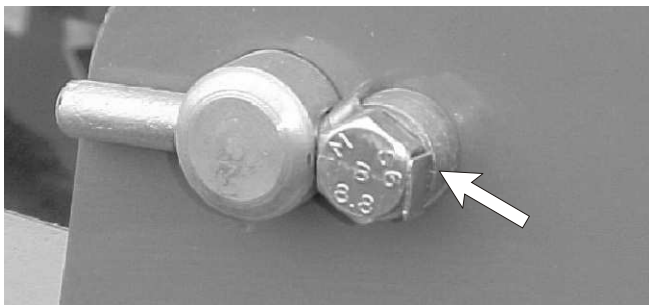

Figure 7.13 - Critical Pin Retainer Bolts

Critical pin retainer bolts have lock tab washers fitted, they should all be present and not damaged in any way.

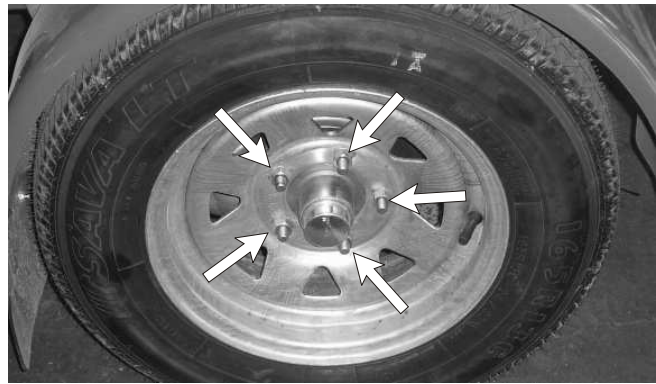

Figure 7.14 - Wheel Nuts

Pay particular attention to all of the wheel nuts and bolts. None should be visibly loose, missing, or deformed.

Also inspect the wheel rim to ensure that it is not damaged or deformed, especially checking the recess where the wheel nuts are seated.

▲ CAUTION

Do not over tighten wheel nuts. Over tightened wheel nuts can damage or deform the wheel rim. This can lead to stability and handling problems when towing.

▲ IMPORTANT

The correct torque setting for the MHP15/44 wheel nuts is 50 lb ft or 68 Nm. Do not tighten beyond these settings.

■ Wheels and Tyres

The MHP15/44 relies on its tyres for towing stability.



Figure 7.15 - Tyre Condition

Check each wheel for tread depth and obvious damage that could cause a blowout.

7. Daily Inspection and Maintenance

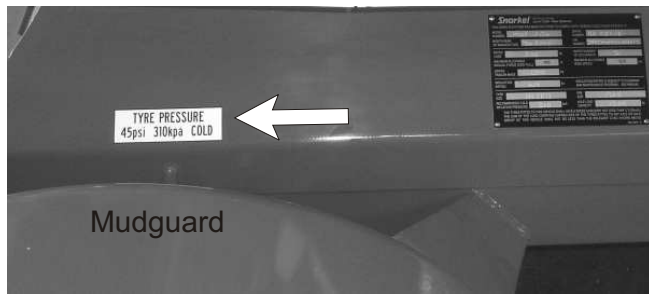

Figure 7.16 - Location of Tyre Pressure Decal

Ensure tyre pressures are maintained according to the decal attached to the chassis behind the mud-guard (fender).

▲ IMPORTANT

The correct tyre pressure for the MHP15/44 is 60psi or 413kPa (readings taken with cold tyres).

■ Structural Damage and Welds

Visually inspect all welds for cracks, all structural members for deformity.

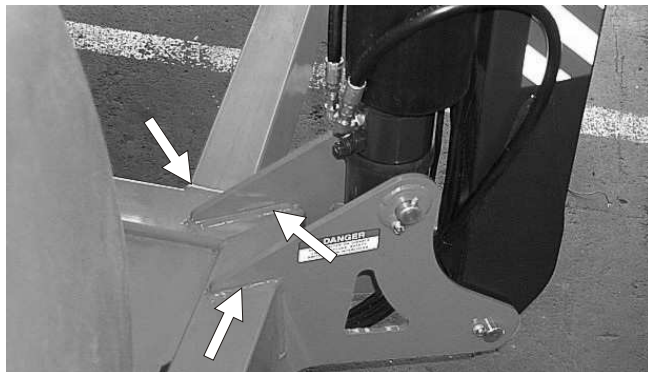

Figure 7.17 - Chassis Welds

Pay particular attention to the chassis welds



Figures 7.18 - Boom Welds

Closely inspect boom welds all the way around, for cracks.

■ Lanyard Anchor Points

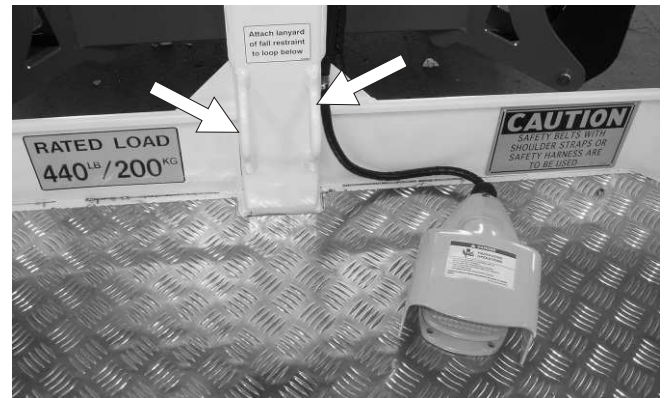

Figure 7.19 - Lanyard Anchor Points

Visually check the lanyard anchor points to see that they are not deformed or cut off.

■ Platform Gravity Gate



Figure 7.20 - Platform Gravity Gate

Check that the gravity gate operates smoothly and does not jam.

7. Daily Inspection and Maintenance

■ Platform Guardrails



Figure 7.21 - Platform Guardrails

Visually inspect the platform guardrails to see that none of the tubing has been cut out, removed, or deformed in any way.

Visually check the guardrail welds to see that none is cracked nor ground down.

■ Flashing Light (option)

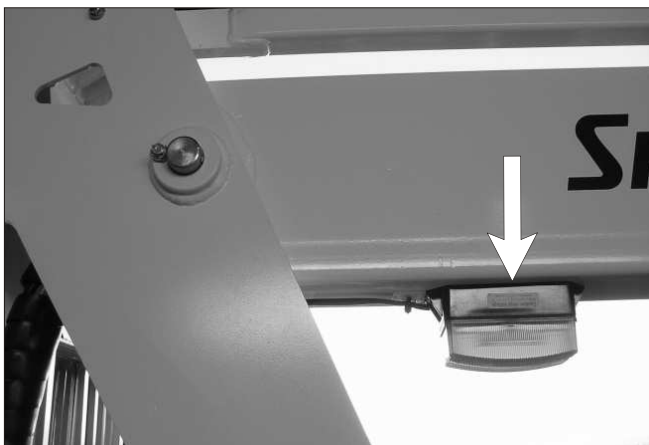

Figure 7.22 - Flashing Light

Visually check the optional flashing light, to see that the light flashes at approximately one flash per second when the motor key switch is turned on.

*Before proceeding with the next section of the daily inspection you will need to **start the engine and set the stabilisers**. Refer to the 'Operation' chapter if you need assistance with this.*

■ Ground Control Switches

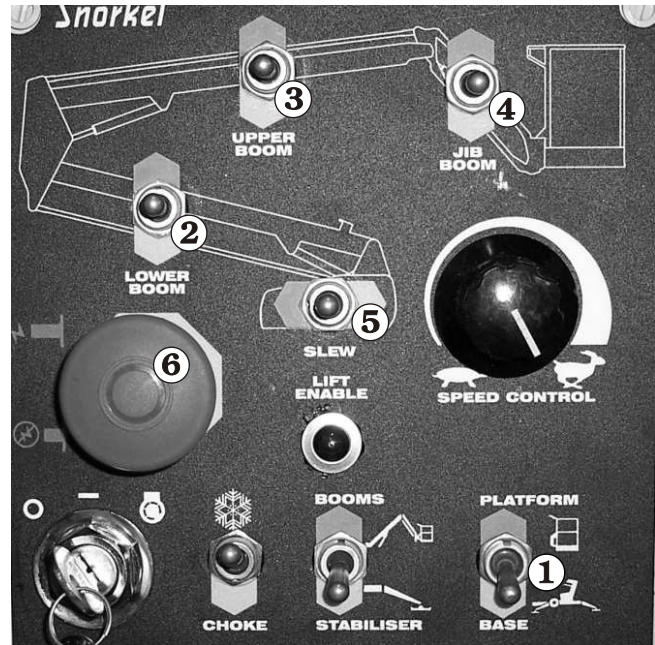

Figure 7.23 - Ground Control Switches

With the Ground/Platform Selector **1** set to ground:

Check that each of the platform moving switches (**2** through to **5**) cause the MHP15/44 to move the way it should.

Check both positions of each switch.

For correct operating procedures see the "Operation" chapter 8.

NOTE

*Pay particular attention to the **Emergency Stop** switch **6** to see that it turns the MHP15/44 engine off when the red button is struck.*

■ Emergency Lower

Lower control box

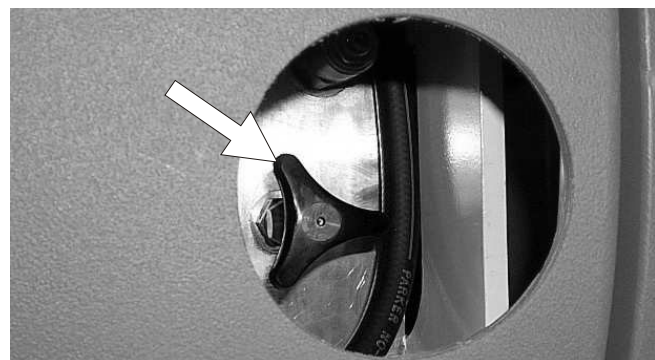

Figure 7.24 - Emergency Lower Valve

7. Daily Inspection and Maintenance

With the booms raised open the **Emergency Lower Valve** at the rear of the column.

The booms should begin to lower. The rate of lowering can be regulated by the amount the valve is opened.

To check the slew function when using the manual emergency lower valve the **Master Key Switch** and **Emergency Stop** switch must be on and the **Platform/ground Selector** must be set to ground.

To slew (with the manual emergency lower valve already open) select the required direction on the slew toggle switch .

NOTE

The manual emergency lower valve must be closed after the test to ensure proper boom operation.

For correct emergency lowering operating procedures see “Emergency Operation” chapter 9.

❑ Upper control box

Emergency lower from the upper control box is achieved by turning the upper control to on and depressing the foot switch whilst operating the **Emergency Lower** switch

To slew the unit select the direction required on the slew toggle switch at the same time. For correct emergency lowering operating procedures see “Emergency Operation” chapter 9.

■ Platform Control Switches

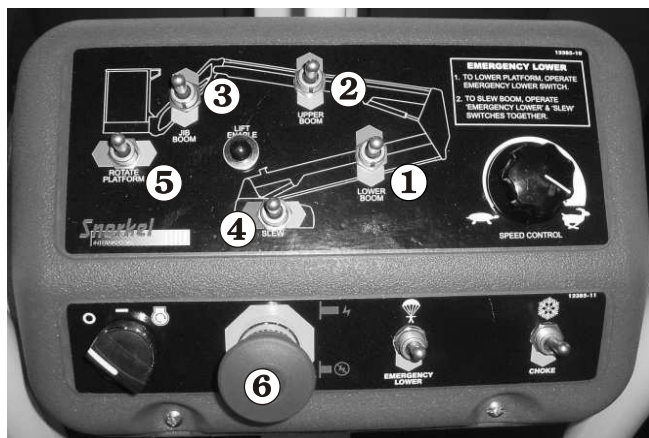

Figure 7.25 - Platform Control Switches

On the ground control box set the **Ground/Platform Selector** to platform.

Check that each of the platform moving switches (1 through to 5) cause the platform to move the way it should.

Check both positions of each switch.

For correct operating procedures see the “Operation” chapter 8.

NOTE

Pay particular attention to the **Emergency Stop** switch 6 to see that it turns the MHP15/44 engine off when struck.

Pay particular attention to the platform foot switch to see that it deactivates the platform moving switches when the foot switch is not stepped on.

At the completion of the above section the unit can be returned to the stowed position.

■ AC Outlet RCD/ELCB (option)

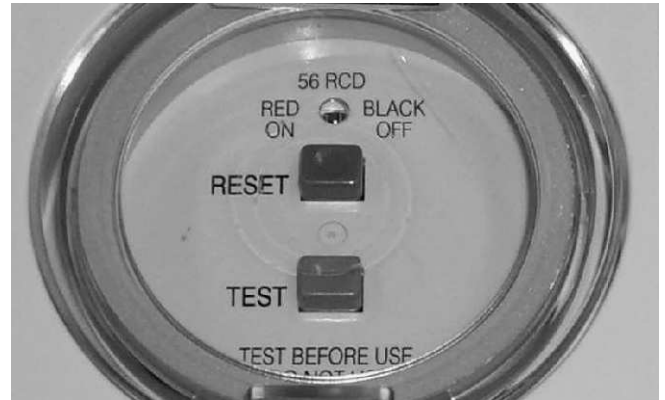

Figure 7.26 - AC Outlet RCD/ELCB

If the MHP15/44 has this option fitted check the RCD works by connecting a power source to the base inlet and an appliance to the platform outlet.

Push the test button on the RCD/ELCB device and the power outlet at the platform should not work.

⚠ CAUTION

RCD/ELCB devices should only be serviced or replaced by a qualified electrician.

■ Placards and Decals

Look to see that all placards and decals are in place and legible. Replace any missing or illegible placards or decals before placing the MHP into service for the daily work shift.

Decal and placard kits for the MHP15/44 are available from Snorkel dealers.

❑ Standard placards and decals

See page 7 - 9 for the following items.

7. Daily Inspection and Maintenance

No	Part No	Description	Req
1	9972-MHP	Serial number plate	1
2	451776	Decal - Hydraulic fluid level	1
3	9751	Decal - NZ made	1
4	302950	Decal - Hydraulic oil level	1
6	12424	Decal - Towing speed	1
7	9207	Decal - Hydraulic oil	1
8	9428	Decal - Danger (Australia only)	1
	1843	Decal - Warning (NZ only)	1
9	569295	Decal - Snorkel	2
10	562426	Decal - Operation manual	1
11	0083426	Decal - Tie down	4
12	12461	Decal - MHP15/44	2
13	9213	Decal - Petrol	1
14	300699	Decal - Operator checklist	1
15	0130025	Decal - Warning	1
16	0323897	Decal - Danger	1
17	476706	Decal - Danger explosive gas	1
18	11420	Decal - Lower control box	1
19	0323899	Decal - Electrocutation hazard	2
20	0150602	Decal - Descending boom	4
21	451986	Decal - Limit switches	6
22	9223-3	Decal - Chevron	8
23	12448	Decal - Outrigger control	1
24	8945	Decal - Vin plate	1
25	7856	Decal - Tyre pressure	2
26	12423-200	Decal - Safe working load (machines with rotator)	1
	12423-227	Decal - Safe working load (machines without rotator)	1
27	99228-1	Decal - Caution	1
28	1772-002K	Decal - Boom lock pin	2
29	0072531	Decal - Electrocutation hazard	1
30	0150448	Decal - Lanyard	1
31	12517	Decal - Auto stabiliser operation	1

7. Daily Inspection and Maintenance

□ Inspection drawing

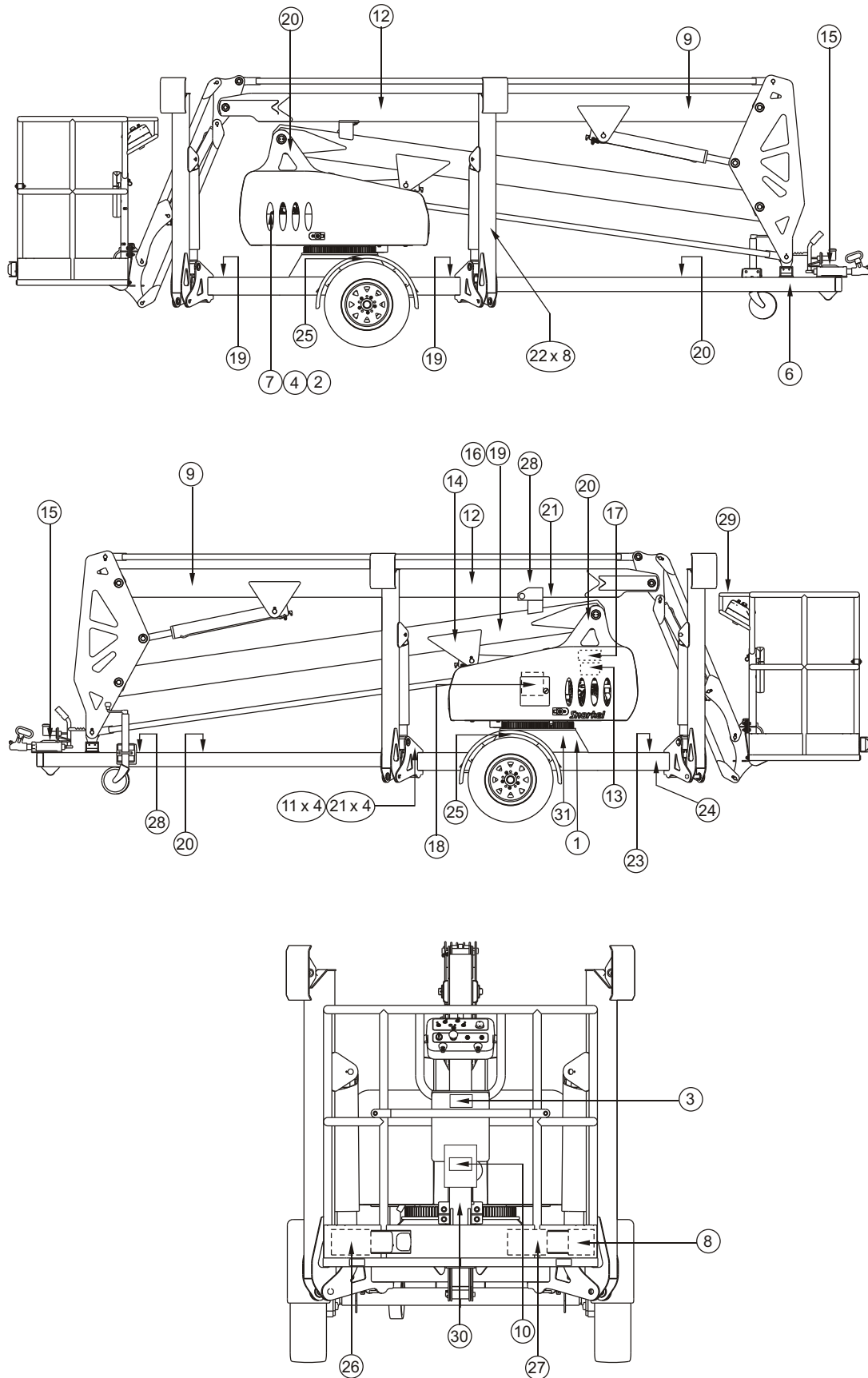

■ Operating Procedures

This chapter explains how to properly start and operate an MHP15/44. Read and understand all the previous chapters in this manual before you begin to operate an MHP15/44.

▲ CAUTION

If you use the MHP15/44 for painting be sure the optional sandblast protection kit is installed to protect the hydraulic cylinder rods from paint. Do not leave the MHP15/44 engine running if you are sandblasting. Sand drawn into the air intake can erode engine parts.

■ Control Stations

An MHP15/44 can be operated from the ground control box or from the platform control box. There are basically two differences between ground control and platform control operations, both are safety related:

1. The ground control box can override the platform control box at any time. If a person operating the machine from the platform becomes incapacitated, a person on the ground can always take over machine control.
2. The outriggers can only be selected from the ground control box and only when the booms are in the stowed position.

▲ DANGER

The MHP15/44 is not Electrically Insulated.

Death or Serious Injury to operating personnel, can occur if the machine should come into contact with energized electrical wires during operation.

DO NOT attempt to operate the MHP15/44 ground controls if the platform, booms, or any other conducting part of an MHP15/44 is in contact with energized electrical wires or if there is an immediate danger of such contact.

NOTE

See the "Electrical Hazard" section, in this manual for a complete explanation of the hazards concerning electricity.

■ Emergency Stopping Lower Control Box

To stop an MHP15/44, from the lower control box push the **Emergency Stop** switch in (see Figure 8.1).

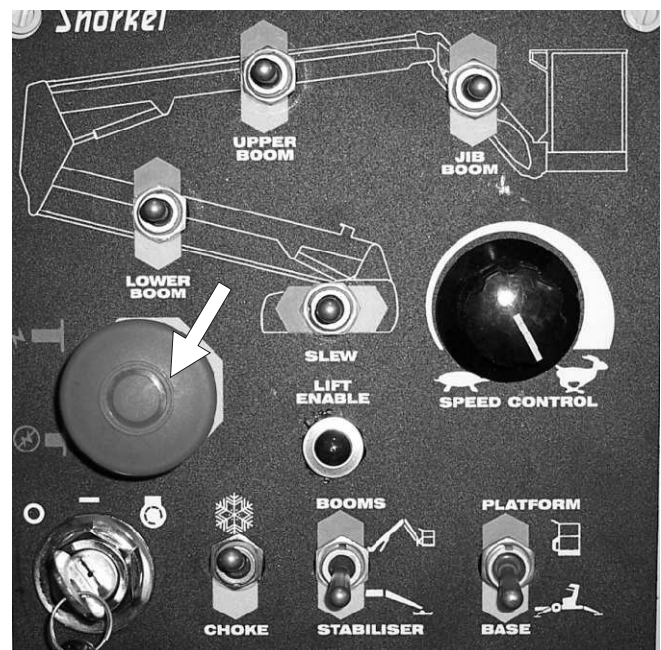

Figure 8.1 - Ground Control Box Emergency Stop Switch Location.

■ Emergency Stopping Upper Control Box

To stop an MHP15/44 from the upper control box push the **Emergency Stop** switch in (see Figure 8.2).



Figure 8.2 - Platform Control Box Emergency Stop Switch Location.

NOTE

For a complete discussion of the **Emergency Stop** switches, see "Controls" chapter 6, in this manual.

8. Operation

■ Operation Considerations

To use this chapter, first decide whether you will be starting and operating the MHP15/44 from the ground control box or the platform control box.

Begin at the section entitled "Starting From Ground Control Box", if you intend to start and run the MHP15/44 from the ground station.

Begin at the section entitled "Starting From Platform Control Box", if you intend to start and run the MHP15/44 from the platform.

■ Starting From Ground Control Box

Before you begin to operate the MHP15/44 from the ground control box, a qualified operator must perform the "Daily Inspection and Maintenance" as described in chapter 7, of this manual.

To start the engine from the ground control box do the following:

1. Set the **Emergency Stop** switch **1** to ON (see Figure 8.3).

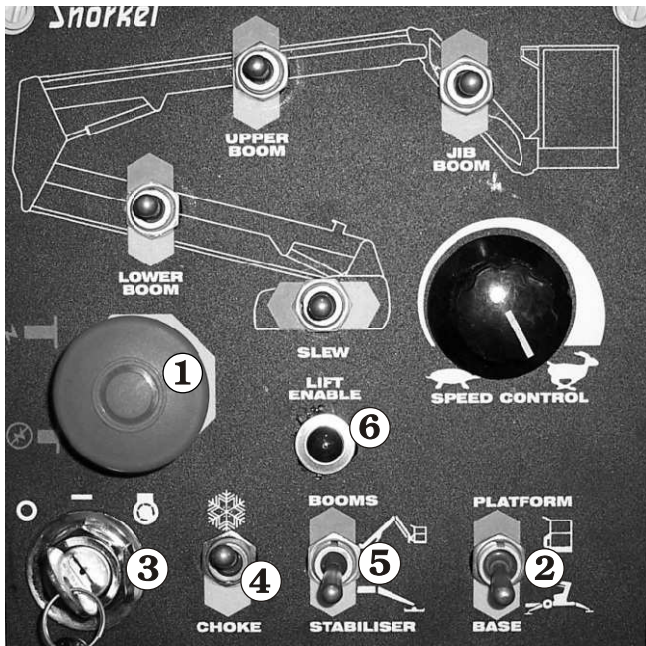

Figure 8.3 - Ground Control Box Starting

2. Set the **Platform/Ground Selector** switch **2** to GROUND (see Figure 8.3).
3. Insert the key **3** (see Figure 8.3) into the **Master Key Switch** and turn the key on.
4. If the engine is at ambient temperature (cold), hold the **Choke / Cold Start Switch** **4** (see Figure 8.3) up throughout the next step.

5. Turn the key to **Start** and hold it there until the engine starts or for a maximum time of 6 seconds. When the engine starts release the key **3** and the choke switch **4**, if you used it (see Figure 8.3).

▲ CAUTION

If the engine does not start in 6 seconds turn the key off and release the choke. Wait 60 seconds before trying to restart the engine again. Continual cranking of the starter motor will only result in its damage.

The engine should now be running, and the MHP15/44 is ready to begin work.

■ Stabiliser Operation

NOTE:

The stabilisers will only function when the booms are stowed. Once the booms are raised the stabilisers will not operate.

Ensure the boom/stabiliser switch (item **5** on the ground control box) (see Figure 8.3) is set to stabiliser.

Activate the stabilisers with the valve levers ensuring that the front stabilisers are lowered first to prevent damage to the jockey wheel.

Activate the rear stabilisers and level the machine using the level bubble adjacent to the control levers.

▲ WARNING

When levelling the machine in either the manual or automatic mode care is required to ensure that all of the foot plates are firmly on the ground, the machine is level and the lift enable light (item **6 Fig 8.3, and item **3** Fig 8.4) is ON before entering the platform.**

■ Self Levelling Stabilisers (Option)

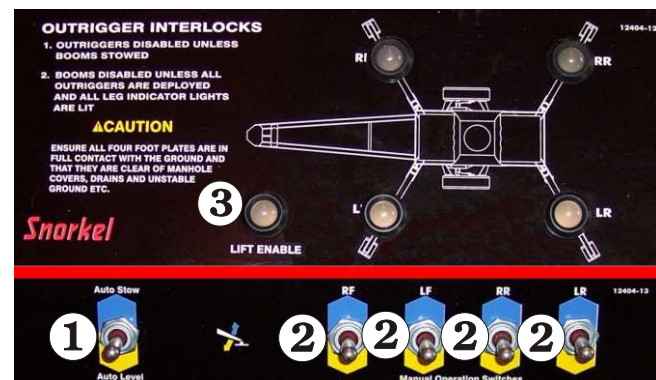

Figure 8.4 - Auto Level Controls

For units fitted with self levelling stabilisers the following applies.

1. Press and hold down the auto level switch **1**.

The stabilisers will lower and the machine will “level” automatically.

NOTE:

Switch **1** is also used to raise the stabilisers to the stowed position. To do so press and hold switch **1** in the auto stow direction and all the stabilisers will raise automatically to the stowed position.

NOTE:

Although this option is designed to automatically set the stabilisers it is also possible to set the stabilisers manually.

□ Setting the stabilisers manually

1. Operate each switch **2** (see Figure 8.4) to raise or lower each stabiliser one at a time. Use the level bubble (see Figure 2.7 in Safety Devices Chapter) to check the machine is level.

▲ WARNING

When levelling the machine in either the manual or automatic mode care is required to ensure that all of the foot plates are firmly on the ground, the machine is level and the lift enable light is ON before entering the platform.

■ Starting From Platform Control Box

Before you begin to operate the MHP15/44 from the platform control box, a qualified operator must perform the "Daily Inspection and Maintenance" as described in chapter 7, of this manual.

To start the engine from the platform control box you must first set some switches on the ground control box, including setting the outriggers and leveling the machine.

(See page 8-2 for information on setting the stabilisers)

1. Insert the key **1** into the **Master Key Switch** at the ground control box and turn the key on (see Figure 8.5).

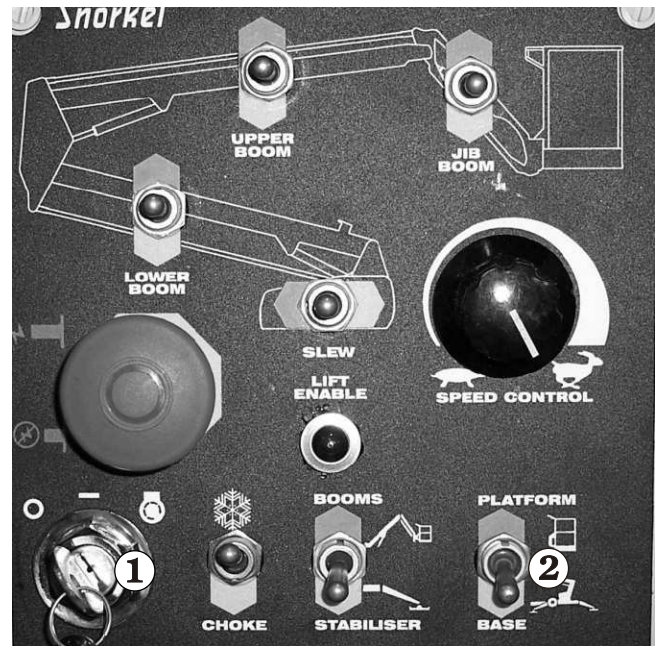

Figure 8.5

2. Set the **Platform/Ground Selector 2** (see Figure 8.5) at the ground control box to PLATFORM.

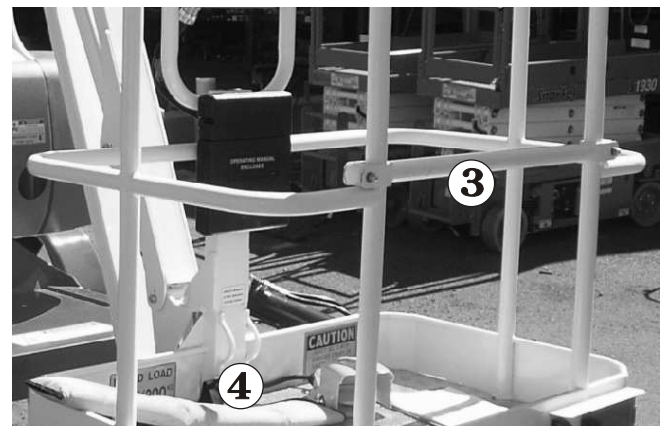

Figure 8.6

3. Enter the platform, close the gravity gate **3**, and attach the lanyard of your fall restraint (safety harness) to one of the anchor points **4** (see Figure 8.6).

8. Operation

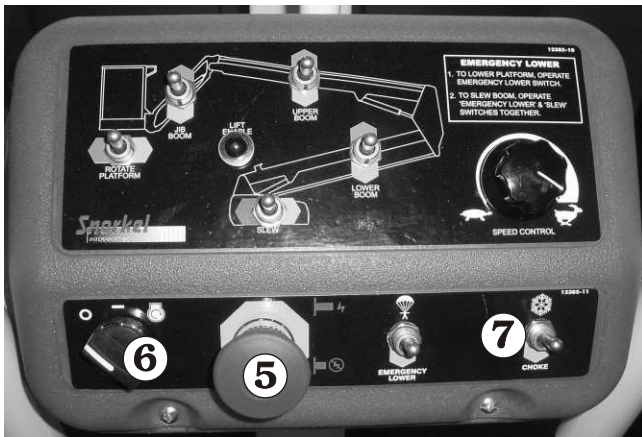

Figure 8.7

4. Set the **Emergency Stop** switch **5** to (ON) (see Figure 8.7).
5. Turn the **Start** switch **6** to ON (see Figure 8.7).
6. If the engine is at ambient temperature (cold), hold the **Choke Switch** **7** (see Figure 8.7) up throughout the next step.
7. Turn the **Start** switch **6** to START and hold it there until the engine starts or for a maximum time of 6 seconds. When the engine starts, release the key (6) and the choke switch **7**, if you used it (see Figure 8.7).

⚠ CAUTION

If the engine does not start in 6 seconds, turn the Start switch OFF and release the choke. Wait 60 seconds before trying to restart the engine again. Continual cranking of the starter motor will only result in its damage.

The engine should now be running, and the MHP15/44 is ready to begin work.

■ Moving The Platform

The engine should already be running (as described earlier in this chapter), before you start this section.

⚠ DANGER

DO NOT operate near energized electrical conductors. Maintain the (M.S.A.D.), Minimum Safe Approach Distance to energized power lines. See the "Electrical Hazard" section, in this manual for a complete explanation of the hazards concerning electricity. Maintain the clearances shown on the decal attached to the platform.

⚠ WARNING

Be certain that the space into which you are about to move the platform, boom, turntable, and/or chassis is free of obstructions. **ALWAYS** look in the direction of movement.

When you operate from the platform control box, be sure that the lanyard of your fall restraint is attached to an anchor point on the platform mount. Also, be sure that platform gate is closed behind you.

□ From Ground Control Box

Each of the ways the platform can move is shown in the following photograph and switch illustration:

The photograph shows the platform switches that cause the platform or booms to move.

These platform moving switches, (1 through 4), will produce the movement as indicated by the illustration's to the right.

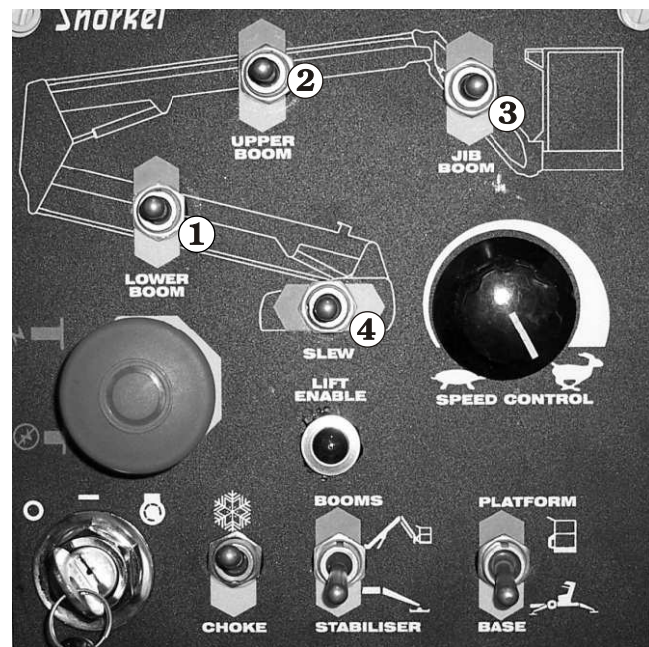

Figure 8.8 - Movement Control, Ground Control Box

□ From Platform Control Box

When you operate from the platform control box, be sure that the lanyard of your fall restraint is attached to an anchor point on the platform mount. Also, be sure the gravity gate is closed. Each of the ways the platform can move is shown in the following photograph and switch illustration:

The photograph shows the platform switches that cause the platform or booms to move.

These platform moving switches, (① through ⑤), will produce the movement as indicated by the illustration's to the right.

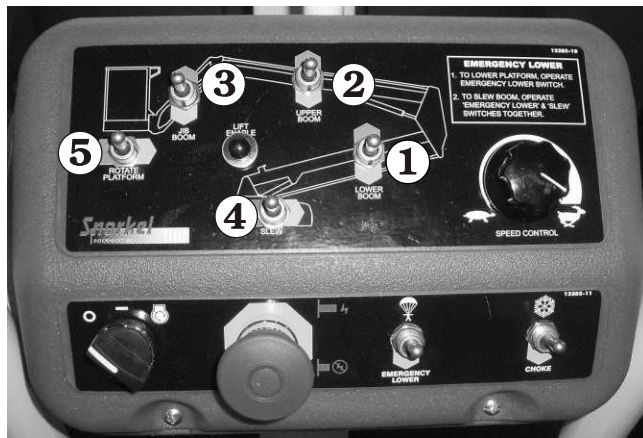

Figure 8.10 - Movement Control, Platform Control Box

You must be stepping on the platform foot switch ⑥ when you use any of the platform moving switches (① through ⑤). The platform foot switch is a safety feature to prevent the platform from moving if a platform moving switch, or controller, is accidentally pushed.



Figure 8.11 - Platform Foot Switch

■ Securing for Day

At the end of each work day the MHP15/44 should be returned to the STOWED POSITION and locked as described under "Stowing" in the "Stowing and Transporting" chapter 10.

■ Emergency Operation Procedures

The following procedures are emergency procedures only. **DO NOT** use them for normal operation. Their purpose is to get the platform and operator safely to ground when the MHP15/44 will not start or some other problem keeps the platform from lowering in the normal way.

□ Operation From Platform Control Box

Switch settings listed in the three steps below must exist at the ground before emergency operation procedures will work at the platform control box:



Figure 9.1

1. The **Master Key Switch** ① must be ON (see Figure 9.1).
2. The **Emergency Stop** switch ② must be (ON) (see Figure 9.1).
3. The **Platform/Ground Selector** switch ③ (see Figure 9.1) must be set to PLATFORM.



Figure 9.2

4. Set the **Emergency Stop** switch ④ to ON (see Figure 9.2).
5. Set the **Start** switch ⑤ (see Figure 9.2) to ON.

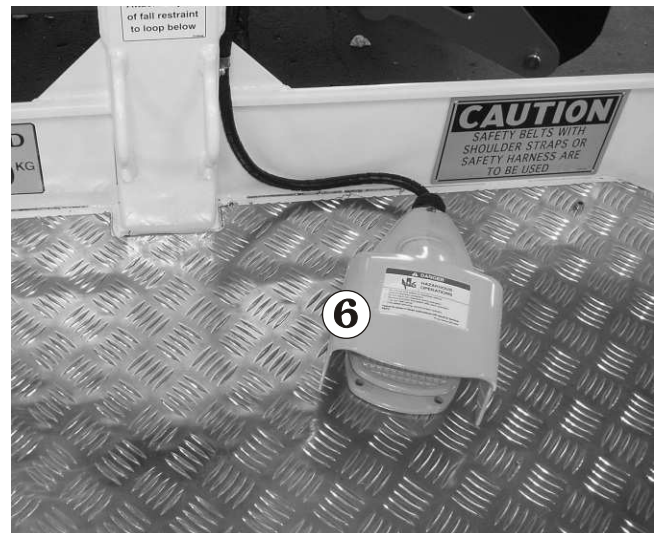

Figure 9.3

6. Step on the platform foot switch ⑥ (see Figure 9.3).

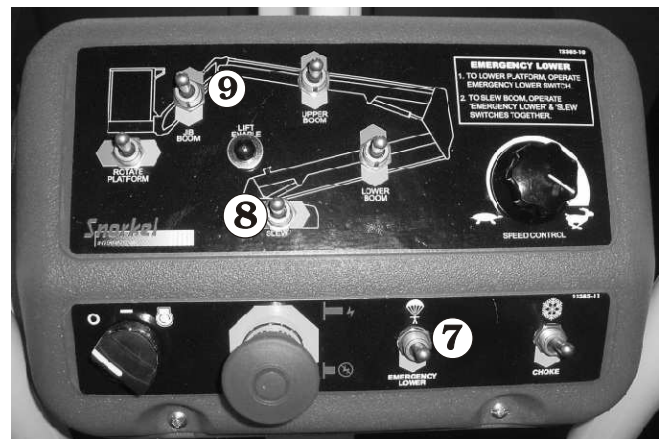

Figure 9.4

7. Hold the **Emergency Lower** switch ⑦ (see Figure 9.4) down and the platform will begin lowering.
8. To lower the jib boom, operate the **Emergency Lower** switch ⑦ and the **Jib Boom Lower** ⑨ switches together (see Figure 9.4).
9. To slew the boom, operate the **Emergency Lower** ⑦ and **Slew** ⑧ switches together (see Figure 9.4).

NOTE:

When emergency lowering, it is only possible to Slew or lower the Jib Boom whilst the Upper and Lower booms are lowering.

9. Emergency Operation

❑ Operation From Ground Control Box



Figure 9.5 - Manual Lower Valve

1. Open manual valve ❶ to lower platform by turning the knob counter clockwise.

NOTE 1:

To slew or lower the Jib Boom when using the Emergency Lowering valve the **Master Key Switch** and the **Emergency Stop Switch** must be on and the **Platform/Ground Switch** must be set to ground (see Figures 9.1 and 9.2).

Operate Slew or Jib Boom Lower at the lower control box whilst the booms are lowering.

NOTE 2:

When emergency lowering, it is only possible to Slew or lower the Jib Boom whilst the Upper and Lower booms are lowering.

NOTE 3:

When using the emergency lowering valve it is important to close the valve fully (turn the knob clockwise) once lowering is complete.

■ Stowing

At the end of each work day (or in preparation for lifting or storage) a qualified operator should put the MHP15/44 into its stowed position then lock by placing the two boom lock pins in position.

□ The correct stowed position is shown here.



Figure 10.1 - Stowed Position

To bring the MHP15/44 into the STOWED POSITION use the controls on the ground control box or platform control box to:

1. Align the lower boom with the boom rest mounted to the drawbar.
2. Fully lower all booms.
3. Insert lower boom pin ① in place (see Figure 10.2) and ensure snap pin ② is correctly locked in place through the boom pin.

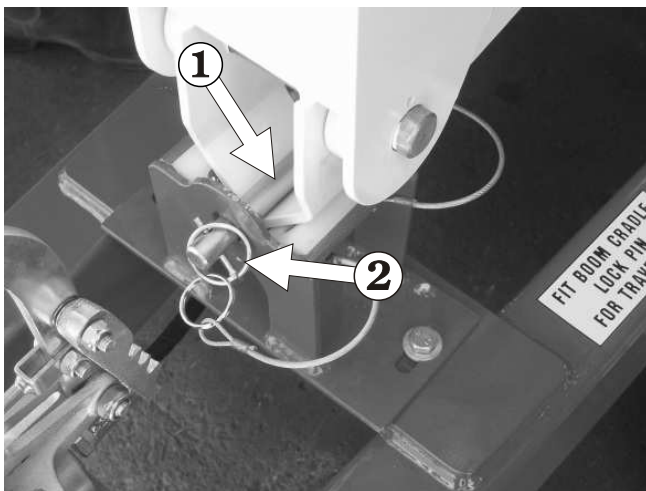

Figure 10.2 - Lower Boom Lock Pin

4. Insert upper boom pin ① in place and ensure the snap pin ② is correctly locked in place through the boom pin (see Figure 10.3)

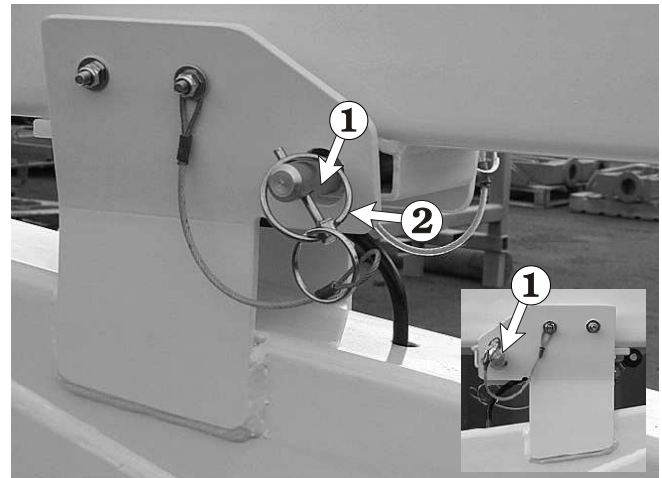

Figure 10.3 - Upper Boom Lock Pin

If using the upper controls go now to the ground controls and:

4. Switch the **Ground / Platform** selector to ground.
5. Set the **Booms / stabiliser** selector to stabiliser.
6. Using the stabiliser controls raise the stabilisers (rear first to avoid damage to the jockey wheel)
7. Set the **Master Key** switch on the ground control box to off and remove the key.

■ Transporting

□ Trailering

When moving the MHP15/44 on a transport trailer the following points must be adhered to.

▲ DANGER

1. The unit must be in the stowed position.
2. Care must be taken when loading the unit onto the trailer that it does not run away. Chock the wheels and apply the handbrake.
3. The MHP15/44 can be loaded by forklift.

10. Stowing and Transporting

□ Forklift points

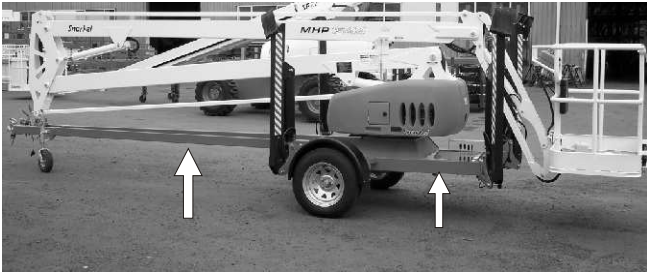

Figure 10.4 - Forklift Points

□ Securing to a Transport Vehicle

4. Tie down only using the 4 tie down points.

DO NOT

- Tie down over the draw bar.
- Tie down over the booms or level rods.
- Tie down over the platform.

Reverse the above procedure after transporting.

■ Towing

The correct size tow ball MUST be used when connecting the draw bar to the towing vehicle. The coupling is stamped with the correct size. Be aware of local transport regulations.

1. Visually inspect the tow ball on the towing vehicle.
2. Ensure the tow ball is matching in size with the tow coupling on the trailer.
3. Ensure the tow ball is mounted correctly and is fitted tightly.
4. Connect the tow coupling and ensure the latching mechanism is working and has latched.
5. Connect the break-away chain to the towing vehicle, unset the reversing lock on the tow coupling.
6. Check that the bolt or D-Clamp on the breakaway chain is able to take the rated load.
7. Connect the trailer road lights to the towing vehicle and test that the functions work.
8. Retract the jockey wheel and place it in the stowed position (see photograph top right).

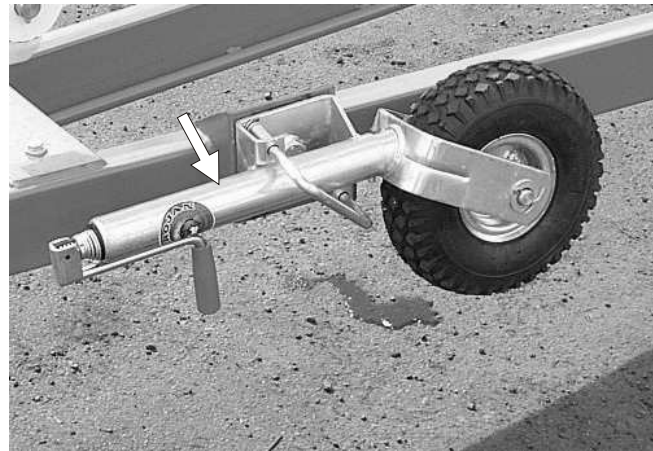

9. Check the covers are secure and no debris or work tools are in the platform.
10. Check both booms are stowed correctly.

▲ DANGER

Death or Serious Injury can result from losing control of a trailer when towing. Never tow above the rated speed marked on the draw bar.

Never tow the unit with an under rated vehicle. Always check manufacturers vehicle load specifications.

■ Air Line To Platform

This consists of $\frac{1}{2}$ " pressure flex yellow hose rated at 150 psi working pressure, fitted with quick disconnect couplers at each end .

■ Dual Fuel

This option consists of an AC motor rated at either 110 or 230 volts AC 50/60Hz mounted under the fiberglass covers. A selector switch is used to change from gasoline to electric. The same controls are used to stop and start the electric motor.

This option is used in shopping malls and other built up areas.

■ 24V DC Battery Power

This option consists of a 24V DC motor and batteries that are used to power all functions.

■ Bi-Energy

This consists of a combination of both gasoline (or diesel) engine and the 24V DC motor to give a Bi-energy option.

■ Work Lights

Rubber encased work lights can be fitted to the platform guardrails. The lights are swivel mounted and each has its own switch.

■ Flashing Light

- For this option see Chapter 2 page 3

■ RCD/ELCB AC Outlet

A 3 core wire rated at 600 volts AC 15 amps is run up the booms as standard.

- For this option see Chapter 2 Page 3.

■ Sandblast Protection Kit

This option consists of a bellows type cover fitted to each boom cylinder shaft.

The bellows prevent sand and paint from damaging the cylinder rods and seals, and thus prevent hydraulic oil leaks.

▲ CAUTION

DO NOT paint or sandblast from an MHP15/44 unless the cylinder rods are protected by bellows.

■ Platform Rotator

This option allows the operator to move the platform around the boom, 45° each side of center, to gain better access to work sites.

11. Options

■ Hazardous Components

Snorkel products may contain materials and objects that potentially could become significant fire or environmental hazards during the lifetime of the machine.

The materials in the following list may be contained in the MHP15/44:

1. Antifreeze (ethylene glycol)
2. Battery, lead/acid
3. Diesel fuel
4. Foam in tires
5. Gasoline
6. Hydraulic oil
7. Liquefied petroleum gas
8. Motor oil

The rest of this chapter lists manufacturers' information you will need if you ever have to control any of the above items during an upset or emergency.

□ Antifreeze (UN 1993)

☞ Fire extinguishing media:

Dry Chemical, foam, or CO₂.

☞ Special fire fighting procedures:

Water spray may be ineffective on fire but can protect fire fighters and cool closed containers. Use fog nozzles if water is used.

▲ DANGER

DO NOT enter confined fire space without full bunker gear. (Helmet with face shield, bunker coats, gloves & rubber boots). Use a NIOSH approved positive pressure self contained breathing apparatus. Keep container tightly closed. Isolate from oxidizers, heat and open flame.

☞ Spill or leak:

Small - mop up with absorbent material and transfer to hood.

☞ Waste disposal method:

Small - evaporate until all vapors are gone. Dispose of remainder by legally applicable methods.

□ Battery, Lead/Acid (UN 2794)

☞ Extinguishing media:

Dry chemical, foam, or CO₂.

☞ Special fire fighting procedures:

Use positive pressure, self contained breathing apparatus.

☞ Unusual fire and explosion hazards:

Hydrogen and oxygen gases are produced in the cells during normal battery operation.

▲ DANGER

Hydrogen gas is flammable and oxygen supports combustion. These gases enter the air through the vent caps. To avoid the chance of a fire or explosion, keep sparks and other sources of ignition away from the battery.

☞ Spill or leak:

Remove combustible materials and all sources of ignition. Contain spill by diking with soda ash (sodium carbonate) or quicklime (calcium oxide). Cover spill with either chemical. Mix well. Make certain mixture is neutral then collect residue and place in a drum or other suitable container. Dispose of as hazardous waste.

▲ DANGER

ALWAYS wear acid resistant boots, face shield, chemical splash goggles, and acid resistant gloves when handling acid spills or leaks.

NOTE

DO NOT release UN-neutralized acid!

☞ Waste disposal method:

Sulfuric Acid: Neutralize as above for a spill, collect residue, and place in a drum or suitable container. Dispose of as hazardous waste.

NOTE

DO NOT flush lead contaminated acid to sewer.

☞ Waste disposal method

Batteries: Send to lead smelter for reclamation following applicable federal, state, and local regulations.

□ Diesel Fuel (NA 1993)

☞ Extinguishing media:

Use water spray, dry chemical, foam, or CO₂.

12. Fire Fighting and Chemical Containment

☞ Special fire fighting procedures:

Use water to keep fire exposed containers cool. If leak or spill has not ignited, use water spray to disperse the vapors and to provide protection for personnel attempting to stop a leak. Water spray may be used to flush spills away from exposures.

☞ Unusual fire and explosion hazards:

Products of combustion may contain carbon monoxide, carbon dioxide, and other toxic materials.

▲ DANGER

DO NOT enter enclosed or confined space without proper protective equipment including respiratory protection.

☞ Spill or leak:

Contain spill immediately in smallest area possible. Recover as much of the product itself as possible by such methods as vacuuming, followed by soaking up of residual fluids by use of absorbent materials.

Remove contaminated items including contaminated soil and place in proper containers for disposal. Avoid washing, draining, or directing material to storm or sanitary sewers .

☞ Waste disposal method:

Recycle as much of the recoverable product as possible.

Dispose of non-recyclable material as a RCRA hazardous waste by such methods as incineration, complying with federal, state, and local regulations.

☐ Foam In Tires

☞ Extinguishing media:

Water, dry chemical, foam, or CO₂.

☞ Special fire fighting procedures:

Evacuate non emergency personnel to a safe area.

☞ Unusual fire and explosion hazards:

Fire fighters should use self contained breathing apparatus. Avoid breathing smoke, fumes, and decomposition products.

Use water spray to drench smoldering elastomer. Product may melt, after ignition, to form flammable liquid.

▲ DANGER

Burning produces intense heat, dense smoke, and toxic gases, such as carbon monoxide, oxides of nitrogen, and traces of hydrogen cyanide.

☞ Spill or leak:

Pick up and handle as any other inert solid material.

☞ Waste disposal method:

Not considered a hazardous material. Dispose of material according to any local, state, and federal regulations.

☐ Gasoline (UN 1203)

☞ Extinguishing media:

Dry chemical, foam, or CO₂.

☞ Special fire fighting procedures:

Water may be ineffective to extinguish, but water should be used to keep fire exposed containers cool. If a leak or spill has not ignited, use water spray to disperse the vapors and to protect personnel attempting to stop a leak. Water spray may be used to flush spills away from areas of potential ignition.

☞ Unusual fire and explosion hazards:

Highly Flammable. Products of combustion may contain carbon monoxide, carbon dioxide and other toxic materials.

▲ DANGER

DO NOT enter enclosed or confined space without proper protective equipment including respiratory protection.

☞ Spill or leak:

Review fire and explosion hazards before proceeding with clean up. Use appropriate personal protective equipment during clean up. Dike spill. Prevent liquid from entering sewers, waterways, or low areas. Soak up with sawdust, sand, oil dry or other absorbent material. Shovel or sweep up.

Remove source of heat, sparks, flame, impact, friction or electricity including internal combustion engines and power tools. If equipment is used for spill cleanup, it must be explosion proof and suitable for flammable liquid and vapor.

12. Fire Fighting and Chemical Containment

NOTE

Vapors released from the spill may create an explosive atmosphere.

☞ Waste disposal method:

Treatment, storage, transportation and disposal must be in accordance with applicable federal, state, provincial, and local regulations.

▲ CAUTION

DO NOT flush to surface water or sanitary sewer system. By itself, the liquid is expected to be a RCRA ignitable hazardous waste.

☐ Hydraulic Oil (UN 1270)

☞ Extinguishing media:

Use water spray, dry chemical, foam, or CO₂.

☞ Special fire fighting procedures:

Water or foam may cause frothing. Use water to keep fire exposed containers cool. Water spray may be used to flush spills away from exposures.

☞ Unusual fire and explosion hazards:

Products of combustion may contain carbon monoxide, carbon dioxide, and other toxic materials.

▲ DANGER

DO NOT enter enclosed or confined space without proper protective equipment including respiratory protection.

☞ Spill or leak:

Contain spill immediately in smallest area possible. Recover as much of the product itself as possible by such methods as vacuuming, followed by soaking up of residual fluids by use of absorbent materials.

Remove contaminated items including contaminated soil and place in proper containers for disposal. Avoid washing, draining or directing material to storm or sanitary sewers .

☞ Waste disposal method:

Recycle as much of the recoverable product as possible.

Dispose of non-recyclable material as a RCRA hazardous waste by such methods as incineration, complying with federal, state, and local regulations.

☐ Liquefied Petroleum Gas (UN 1075)

☞ Extinguishing media:

Water spray. Class A-B-C or BC fire extinguishers.

☞ Special fire fighting procedures:

Stop flow of gas. Use water to keep fire exposed containers cool. Use water spray to disperse unignited gas or vapor.

If ignition has occurred and no water available, tank metal may weaken from over heating. Evacuate area. If gas has not ignited, LP gas liquid or vapor may be dispersed by water spray or flooding.

☞ Unusual fire and explosion hazards:

Highly Flammable. Products of combustion may contain carbon monoxide, carbon dioxide and other toxic materials.

▲ DANGER

DO NOT enter enclosed or confined space without proper protective equipment including respiratory protection.

☞ Spill or leak:

Keep public away. Shut off supply of gas. Eliminate sources of ignition. Ventilate the area. Disperse with water spray.

Contact between skin and these gases in liquid form can cause freezing of tissue causing injury similar to thermal burn.

NOTE

Vapors released from the spill may create an explosive atmosphere.

☞ Waste disposal method:

Treatment, storage, transportation and disposal must be in accordance with applicable federal, state, provincial, and local regulations.

☐ Motor Oil (UN 1270)

☞ Extinguishing media:

Use water spray, dry chemical, foam, or CO₂.

12. Fire Fighting and Chemical Containment

Special fire fighting procedures:

Water or foam may cause frothing. Use water to keep fire exposed containers cool. Water spray may be used to flush spills away from exposures.

Unusual fire and explosion hazards:

Products of combustion may contain carbon monoxide, carbon dioxide, and other toxic materials.

⚠ DANGER

DO NOT enter enclosed or confined space without proper protective equipment including respiratory protection.

Spill or leak:

Contain spill immediately in smallest area possible. Recover as much of the product itself as possible by such methods as vacuuming, followed by soaking up of residual fluids by use of absorbent materials.

Remove contaminated items including contaminated soil and place in proper containers for disposal. Avoid washing, draining or directing material to storm or sanitary sewers .

Waste disposal method:

Recycle as much of the recoverable product as possible.

Dispose of non-recyclable material as a RCRA hazardous waste by such methods as incineration, complying with federal, state, and local regulations.

■ Troubleshooting

All of the actions described in this chapter may be performed by an MHP15/44 operator, a trained and qualified service technician is not required.

The first column, of the following chart, lists some common problems encountered by MHP15/44 operators.

The second column lists some of the causes for each problem. The third column lists remedies.

□ Operator Troubleshooting Chart

▲ CAUTION

Any problem that cannot be fixed by actions listed below should be referred to a trained and qualified MHP15/44 service technician.

Problem	Cause	Remedy
Engine will not crank.	1. Flat battery.	Replace / charge battery.
	2. Main circuit breaker, in ground control box, has tripped..	Reset circuit breaker , then try to start the engine. If it will not start, refer the problem to a qualified service technician.
	3. Loose battery terminals .	Tighten battery leads at battery.
Engine cranks but will not start.	1. Out of fuel.	Fill the engine with the correct type / grade of fuel.
	2. Fuel tap off.	Locate fuel tap on engine and turn to ON.
Engine runs but no outrigger function.	1. Leg / boom switch in lower control box incorrectly set	Switch to Outriggers to operate outriggers.
Engine runs but no boom function.	1. Speed control set too SLOW.	Turn Speed Control C.W. until function starts.
	2. Outriggers not set correctly.	All outriggers must be set on firm ground before boom functions will operate.
	3. Lack of hydraulic oil.	A. Check hydraulic system for leaks. B. Top up the oil tank with the correct type / grade of hydraulic oil.
Bleed down at platform inoperative.	1. Flat battery.	A. Charge / replace the battery. B. Use Manual Bleed Down from lower station.

13. Operator's Troubleshooting

A

AC outlet RCD/ELCB, 7-7

Additional information

see Introduction - page iv

Automatic Shut-offs

Circuit Breakers

Main Circuit Breaker, 5-1

Outriggers, 5-1

B

Battery fluid level, 7-3

Battery terminals, 7-3

Bolts and fasteners, 7-4

Booms Identification, 3-5

C

Controls

Control switches

Boom Speed, 6-2, 6-3

Choke/Cold Start, 6-2, 6-3, 8-2, 8-4

Emergency Lower, 6-3

Emergency Stop, 6-2, 6-3, 8-1

Emergency Stop switch, 8-2, 8-4, 9-1

Foot Switch, 6-3

Jib Boom, 6-2, 6-3

Lift Enable, 6-2

Lower Boom, 6-2, 6-3

Master Key Switch, 6-2, 7-1, 8-2, 8-3, 9-1

Platform Rotate, 6-3

Platform/Ground Selector, 6-2, 8-2, 8-3, 9-1

Slew, 6-2, 6-3

Stablizer / Boom Secector Switch, 6-2

Start, 6-3, 8-4, 9-1

Upper Boom, 6-2, 6-3

Ground Control Box, 6-2

Control switches, 6-2

Controls location illustration, 6-2

Platform Control Box

Control switches, 6-3

Controls and Control Decals Locations, 6-1

D

Daily Inspection and Maintenance Table, 7-1

E

Electrical

Electrocution, 1-3, 8-1

Electrical Hazard Warning

see Electrical Hazard - page i

Emergency lower, 7-6

Emergency Operation, 9-1

Operation From Ground Control Box, 9-2

Operation From Platform Control Box, 9-1

Procedures, 9-1

Engine

Cooling system, 3-2

Displacement, 3-2

Engine oil level, 7-2

Fuel, 3-2

Fuel consumption, 3-2

Fuel grade, 3-2

Fuel leaks, 7-2

Fuel tank cap, 7-2

Ignition system, 3-2

Make, 3-2

Model, 3-2

Oil capacity, 3-2

Oil grade, 3-2

Type, 3-2

Engine Data, 3-2

F

Falling hazards, 1-3

Flashing light, 7-6

G

Gauges

Hourmeter, 4-1

Hydraulic Oil Level, 4-1

Level Bubble, 4-1

General Specifications, 3-1

H

Hazardous Components, 12-1

Battery, Lead/Acid (UN 2794), 12-1

Gasoline (UN 1203), 12-2

Hydraulic Oil (UN 1270), 12-3

Motor Oil (UN 1270), 12-3

Hydraulic oil

Filler cap, 7-3

Hydraulic oil level, 7-3

I

Inspection

Operators daily inspection, 7-1

Inspection and Maintenance Table, 7-1

L

Left side view of machine, 3-6

Light Flashing, 7-6

Index

Lower control box, 7-6

M

Maintenance personnel

see Introduction - page iii

Minimum Safe Approach Distance

see Electrical Hazard - page ii

N

Nomenclature And Serial Numbers, 3-5

O

Operating Procedures, 8-1

Control Stations, 8-1

Emergency Stopping, 8-1

Moving The Platform, 8-4

Starting From Ground Control Box, 8-2

Starting From Platform Control Box, 8-3

Operation, 8-1

Operators

Qualified, 7-1, 8-2

Other Safety Devices, 2-1

Overall Dimensions MHP15/44, 3-3

P

Placards and decals, 7-7

Inspection drawing, 7-9

Standard placards and decals, 7-7

Platform

Foot switch, 8-5

Lanyard anchor points, 7-5

Pre-start Inspection, 1-1

Q

Qualified operators

see Introduction - page iii

R

RCD/ELCB Outlet (option), 5-1

Responsibilities of owners and users

see Introduction - page iv

Right side view of machine, 3-5

S

Safe Operation, 1-1

Safety Alerts, Caution, Danger, Warning

see Introduction - page iii

Safety Decals and Placards, 1-4

Safety Devices

Bubble level, 2-2

Emergency Stop Switches, 2-1

Flashing light, 2-3

Foot switch, 2-2

Gravity gate, 2-2

Guardrails, 2-2

Lanyard anchor points, 2-1

RCD/ELCB AC outlet, 2-3

Safety Device Information, 2-1

Safety precautions

Fuel Handling Precautions, 1-4

Hydraulic Systems, 1-3

Sandblast protection kit, 8-1

Securing for Day, 8-5

Stowing

Trailing

Forklift points, 10-2

Stowing the MHP15/44, 10-1

Boom lock pins, 10-1

Structural damage and welds, 7-5

Boom welds, 7-5

T

Tipover hazard, 1-3

Towing, 10-2

Bolt, D-Clamp or attaching device, 10-2

Covers and debris, 10-2

Jockey wheel, 10-2

Latching mechanism, 10-2

Rated speed, 10-2

Road lights, 10-2

Tow ball, 10-2

Under rated vehicle, 10-2

Transporting

Trailing

Forklift points, 10-2

Transporting the MHP15/44, 10-1

Securing to a Transport Vehicle, 10-2

Trailing, 10-1

Troubleshooting, 13-1

Operator Troubleshooting Chart, 13-1

W

Warranty - Limited

see inside front cover

Wheels and tyres, 7-4

Wiring harnesses, 7-2

Loose connections, 7-2

Work Place Inspection and Practices, 1-1

Working Envelope MHP15/44, 3-4

