

SL26SL/SL30SL

SPEED LEVEL



- The original Speed Level sigma lift
- Climbs gradients of up to 50%
- Auto-levelling without the need for outriggers
- Suitable for most terrains
- Powerful 4x4 drive
- Ideal for rough terrain or work at height on sloped ground

 **snorkel**
www.snorkellifts.com

SPEED LEVEL

SL26SL/SL30SL

DIMENSIONS	SL26SL	SL30SL
Max. working height	10.0m	11.0m
Max. platform height (A)	8.0m	9.0m
Platform size (stowed)	1.72m x 3.66m	1.72m x 4.23m
Platform size (extended)	1.72m x 4.6m	n/a
Overall width (D)	2.13m	2.13m
Overall length (C)	3.79m	4.3m
Stowed height (B)	2.6m	2.6m
Min. height (guardrails folded)	1.7m	1.7m
Chassis ground clearance	305mm	305mm
Axle ground clearance	195mm	195mm

PERFORMANCE	SL26SL	SL30SL
Platform capacity (SWL)	680kg	590kg
Max. drive height	8.0m	9.0m
Max. wind speed	12.5m/s	12.5m/s
Max. drive speed (stowed)	5.2km/h	5.2km/h
Max. drive speed (elevated)	0.8km/h	0.8km/h
Raise/lower time	21/32 seconds	24/36 seconds
Gradeability	50%	50%
Max. levelling, front to rear	9°	9°
Max. levelling, side to side	13°	13°
Inside turning radius	3.9m	3.9m
Outside turning radius	5.64m	5.64m
Tyres	26 x 12.00 - 12 NHS Pneumatic	
Controls	proportional joystick	
Drive system	4 wheel drive with hydraulic motors and flow dividers	

POWER	SL26SL	SL30SL
Power source	Kubota D-902 water-cooled diesel	

WEIGHT	SL26SL	SL30SL
Weight	3,200kg	3,400kg

LEVELLING CAPABILITIES

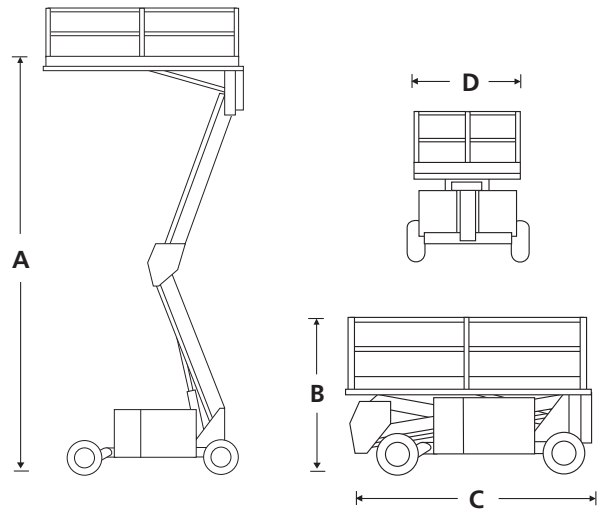
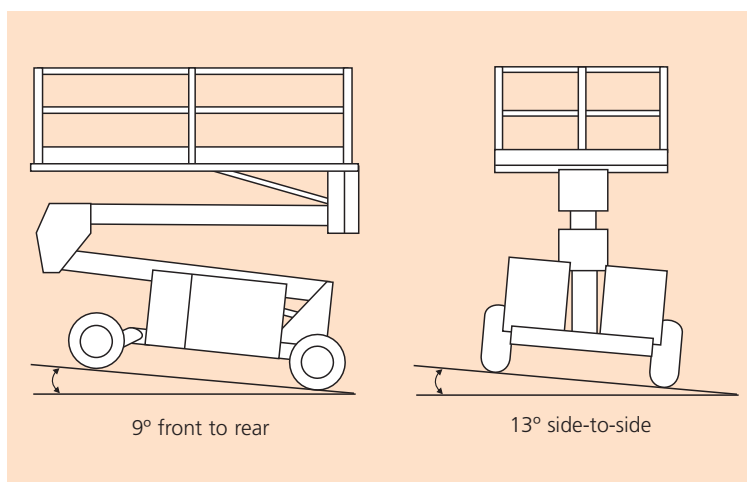

STANDARD FEATURES

- Automatic powered platform levelling
- Oscillating front axle
- High grip, open tread deck (SL30SL)
- Roll-out deck extension (SL26SL)
- Descent alarm
- High grip all-terrain tyres
- Dual multi-disc brakes
- Proportional controls
- Power line to platform
- Fold-down guardrails
- Flashing amber light
- Hour meter & on-board diagnostics display
- Horn
- 2 year parts & labour, 5 year structural warranty
- CE approved

OPTIONS

- Special paint colours
- All motion alarm
- Diesel exhaust scrubber
- Environmental (green) oil
- Hydraulic generator 110V/240V

snorkel

Vigo Centre, Birtley Road,
Washington, Tyne & Wear,
NE38 9DA, U.K.

t: +44 (0) 845 1550 057

e: sales@snorkellifts.com

www.snorkellifts.com