

# SL26SL/SL30SL

**SPEED LEVEL**



- The original Speed Level sigma lift
- Climbs gradients of up to 50%
- Auto-leveling without the need for stabilizers
- Suitable for most terrains
- Powerful 4x4 drive
- Ideal for rough terrain or work at height on sloped ground

**snorkel**  
[www.snorkellifts.com](http://www.snorkellifts.com)

## SPEED LEVEL

DIMENSIONS	SL26SL	SL30SL
Max. working height	31 ft 6 in	35 ft 4 in
Max. platform height (A)	25 ft 6 in	29 ft 4 in
Platform size (stowed)	5 ft 8 in x 12 ft	5 ft 8 in x 13 ft 11 in
Platform size (extended)	5 ft 8 in x 15 ft	n/a
Overall width (D)	7 ft	7 ft
Overall length (C)	12 ft 5 in	14 ft 1 in
Stowed height (B)	8 ft 6 in	8 ft 6 in
Min. height (guardrails folded)	65 in	65 in
Chassis ground clearance	12 in	12 in
Axle ground clearance	7.6 in	7.6 in

PERFORMANCE	SL26SL	SL30SL
Platform capacity (SWL)	1,500 lbs	1,300 lbs
Max. wind speed	28 mph	28 mph
Max. drive height	25 ft 6 in	29 ft 4 in
Max. drive speed (stowed)	3.2 mph	3.2 mph
Max. drive speed (elevated)	0.5 mph	0.5 mph
Raise/lower time	21/32 seconds	24/36 seconds
Gradeability	27° / 50%	27° / 50%
Max. levelling, front to rear	9°	9°
Max. levelling, side to side	13°	13°
Inside turning radius	12 ft 10 in	12 ft 10 in
Outside turning radius	18 ft 6 in	18 ft 6 in
Tires	26 x 12.00 - 12 NHS Pneumatic	
Controls	Proportional joystick	
Drive system	4 wheel drive with hydraulic motors and flow dividers	

POWER	SL26SL	SL30SL
Power source	Kubota D-902 water-cooled diesel engine	

WEIGHT	SL26SL	SL30SL
Weight	7,053 lbs	7,495 lbs

### LEVELING CAPABILITIES

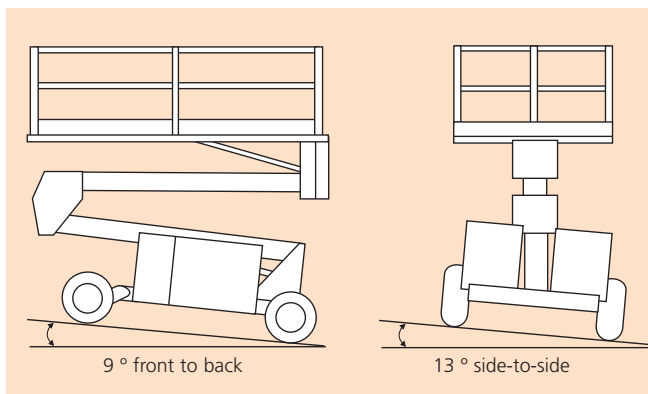

# SL26SL/SL30SL

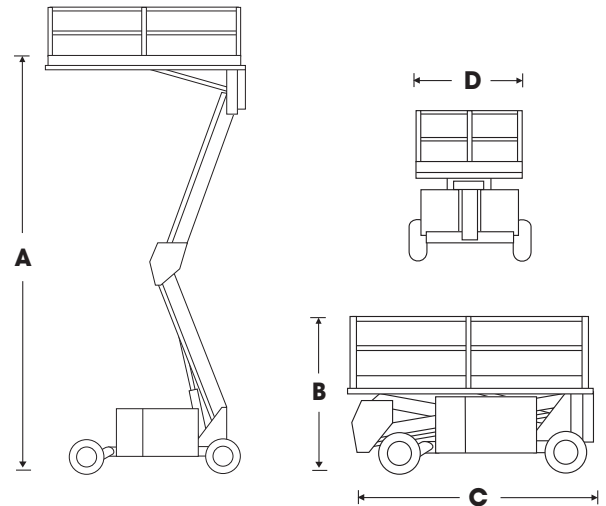

### STANDARD FEATURES

- Automatic powered platform leveling
- Oscillating front axle
- High grip, open deck tread (SL30SL only)
- Roll-out deck extension (SL26SL only)
- Descent alarm
- Hour meter
- High grip, all-terrain tires
- Dual multi-disc brakes
- Proportional controls
- Power line to platform
- Fold-down guardrails
- Horn
- 2 year parts & labor, 5 year structural warranty
- ANSI compliant

### OPTIONS

- Special paint colors
- Diesel exhaust scrubber
- Flashing amber light
- Environmental green oil
- CSA compliant

**snorkel** www.snorkellifts.com

P.O. Box 1160  
 St. Joseph, MO 64502-1160, USA  
 Tel: 1 (785) 989-3000  
 Toll-free: 1 (800) 255-0317  
 Fax: 1 (785) 989-3070  
 Email: sales.usa@snorkellifts.com