

**Crane specification**

 Serial number **599xxx**  
 Year of construction **20xx**



 Crane group : A3 as per FEM 1.001  
 Loadspectrum : Q1 as per FEM 1.001  
 Classification : U4 as per FEM 1.001  
 Stability : as per FEM 1.001

 Max. load  
**9,0 tonne**

 Max.radius  
with max. load  
**13 m**

 Max. capacity  
**117 tm**

 Max. jib length  
**50 m**

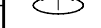
Speeds		Jib horizontal / jib 30° luffed	
m/min	kg		
20	9000		0 - 70 m/min
32	4500		0 - 0,9 rpm
50	2250		
75	0		

 All motions with hydraulic proportional controls.  
 Luffing the jib 30° can be controlled from crane cab or by remote control.  
 The crane should be folded in at wind force 9 (Bf) (21 m/sec) or when not in use for a longer period.

 Counterweight crane: 10380 kg.  
 Continues slewing (360°) with outriggers out and support pads down.  
 Crane can be driven in its erected position under special conditions (refer user guide).

 Rated lift capacity is net capacity.  
 Always two parts of line.  
 Max. line pull force: 4500 kg.  
 Operating temperature range from: -15°C till + 40°C.  
 Sail area of the load max.: 1,0 m²/ ton.

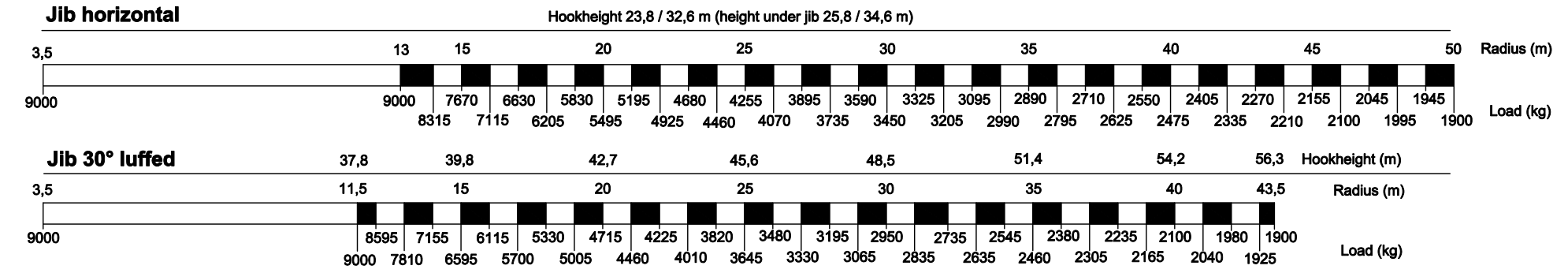
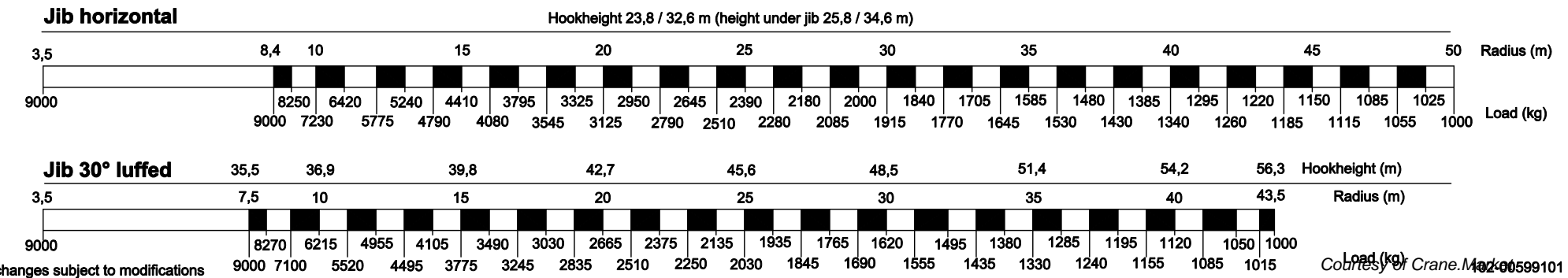
 Outrigger positioned according to lifting chart  
 Outrigger support base : **7,50 m x 7,66 m**.  
 Operation allowed up to wind force 8 Bf (17 m/sec).  
 Outrigger support base : **7,50 m x 5,72 m**.  
 Operation allowed up to wind force 8 Bf (17 m/sec).  
**Max. outrigger force: 440kN.**
**Lifting chart Outrigger support base 7,50 m x 7,66 m**

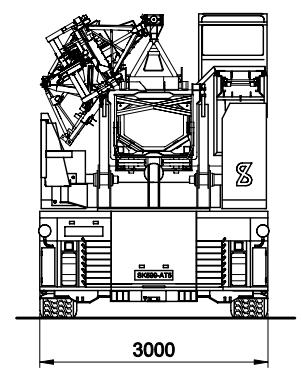
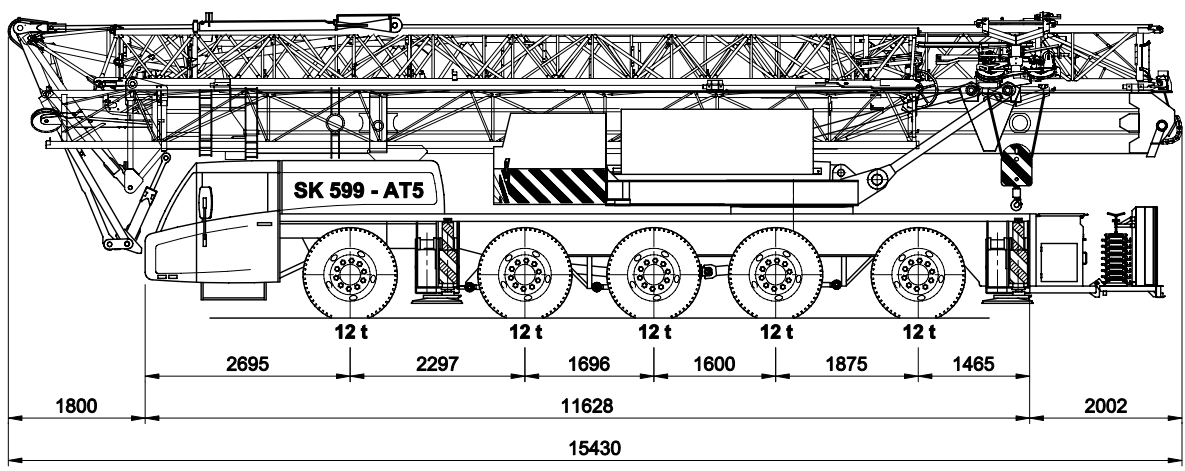
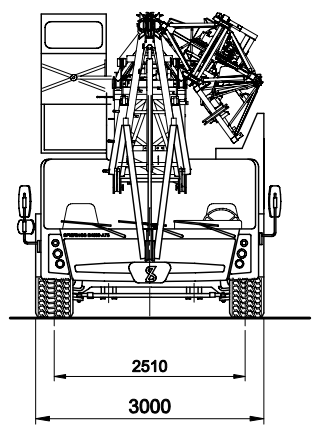
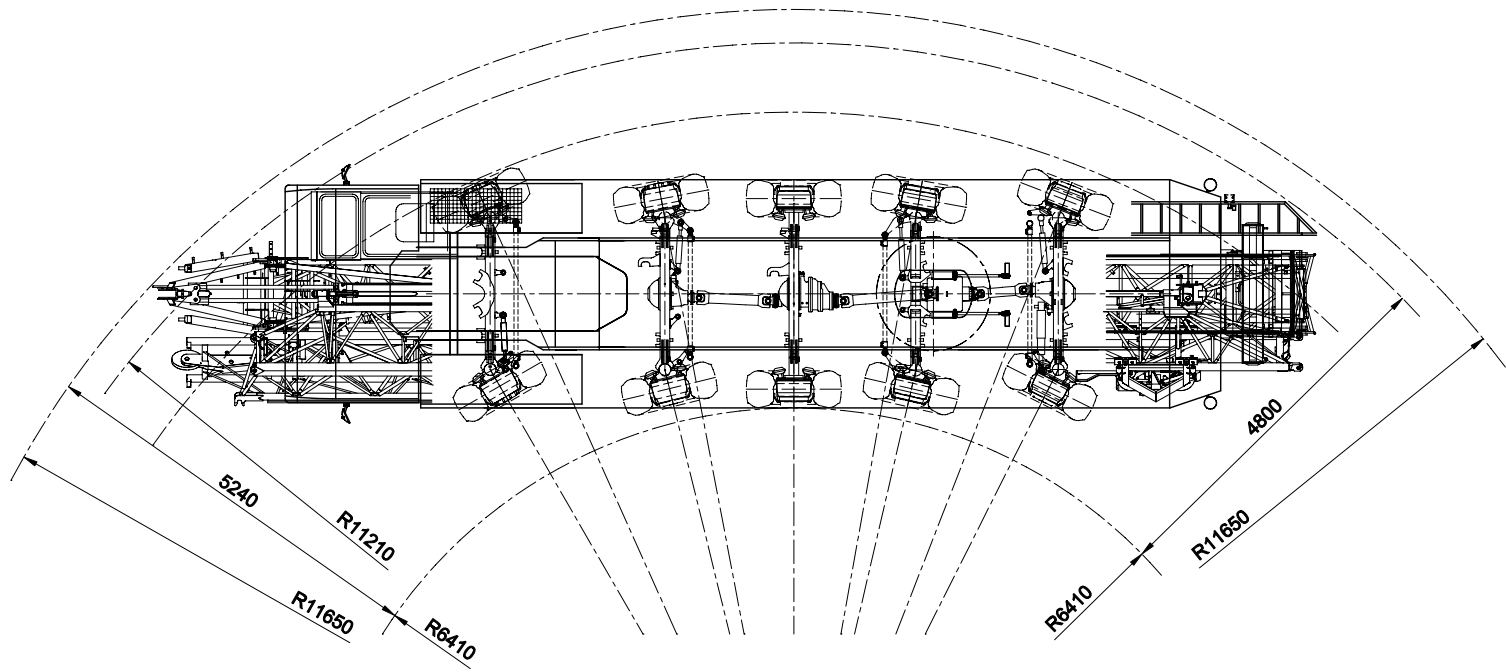
**Lifting chart Outrigger support base 7,50 m x 5,72 m**



# Spierings Hydraulic Folding Crane

## SK 599 - AT5

Total weight: 60000 kg  
changes subject to modifications

**SPIERINGS**  
MOBILE CRANES

Merwedestraat 15  
5347 KZ Oss NL  
Tel. +31 (0)412-626964  
Fax +31 (0)412-645299  
[www.spieringscranes.com](http://www.spieringscranes.com)

Courtesy of Crane 102

# SPIERINGS HYDRAULIC FOLDING CRANE SK599-AT5

599xxx

## Erection procedure of the crane

- Max. outrigger force : 440 kN
- Outrigger support pads : 750x600 mm
- Ground pressure : 1,00 N/mm<sup>2</sup>
- Jib can be unfolded through 360°
- Luffing the jib 30° can be controlled from the crane cab or remote control
- Outrigger support plates : 1000x1000 mm
- surface : 1,00 m<sup>2</sup>
- Ground pressure : 0,44 N/mm<sup>2</sup>

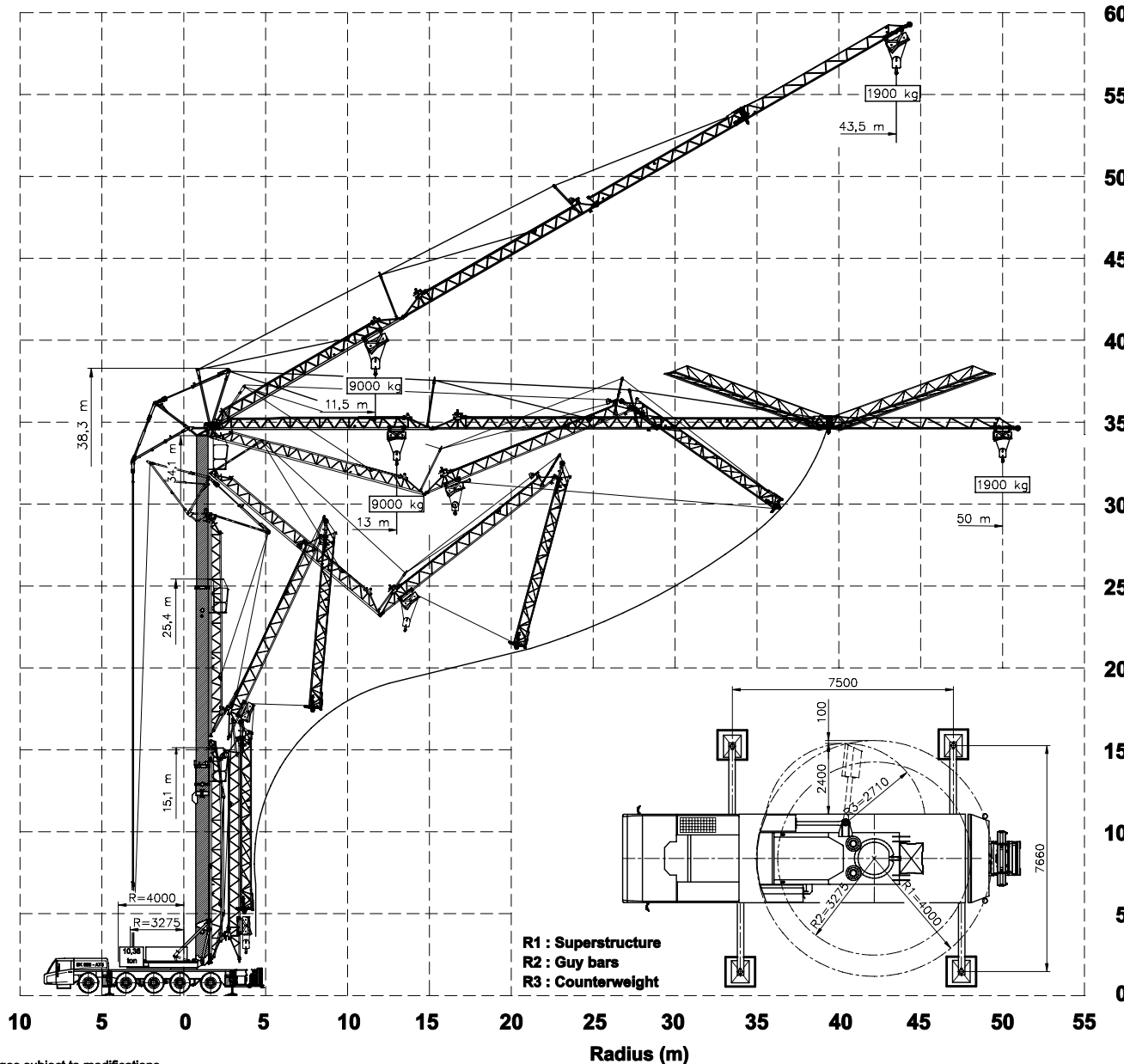

**SPIERINGS**  
MOBILE CRANES

Merwedestraat 15  
5347 KZ Oss NL  
Tel. +31 (0)412-626964  
Fax +31 (0)412-645299  
[www.spieringscranes.com](http://www.spieringscranes.com)

# SPIERINGS HYDRAULIC FOLDING CRANE

## SK599-AT5

599xxx

**Hoisting Specifications**

**Outrigger support base**

**7,50 m x 7,66 m**

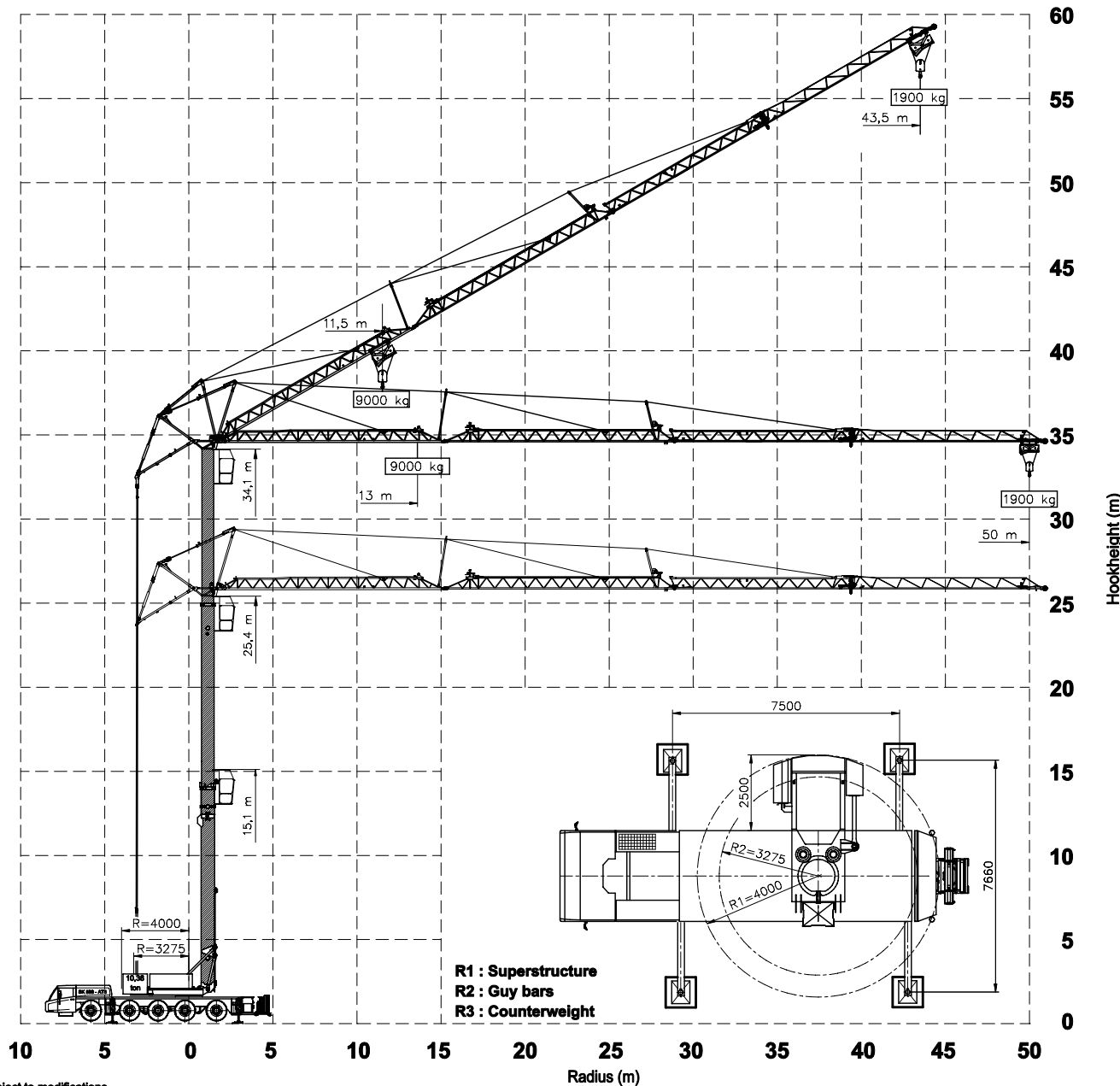

**SPIERINGS**  
MOBILE CRANES

Merwedestraat 15  
5347 KZ Oss NL  
Tel. +31 (0)412-626964  
Fax +31 (0)412-645299  
[www.spieringscranes.com](http://www.spieringscranes.com)

# SPIERINGS HYDRAULIC FOLDING CRANE

## SK599-AT5

599xxx

**Hoisting Specifications**

**Outrigger support base**

**7,50 m x 5,72 m**

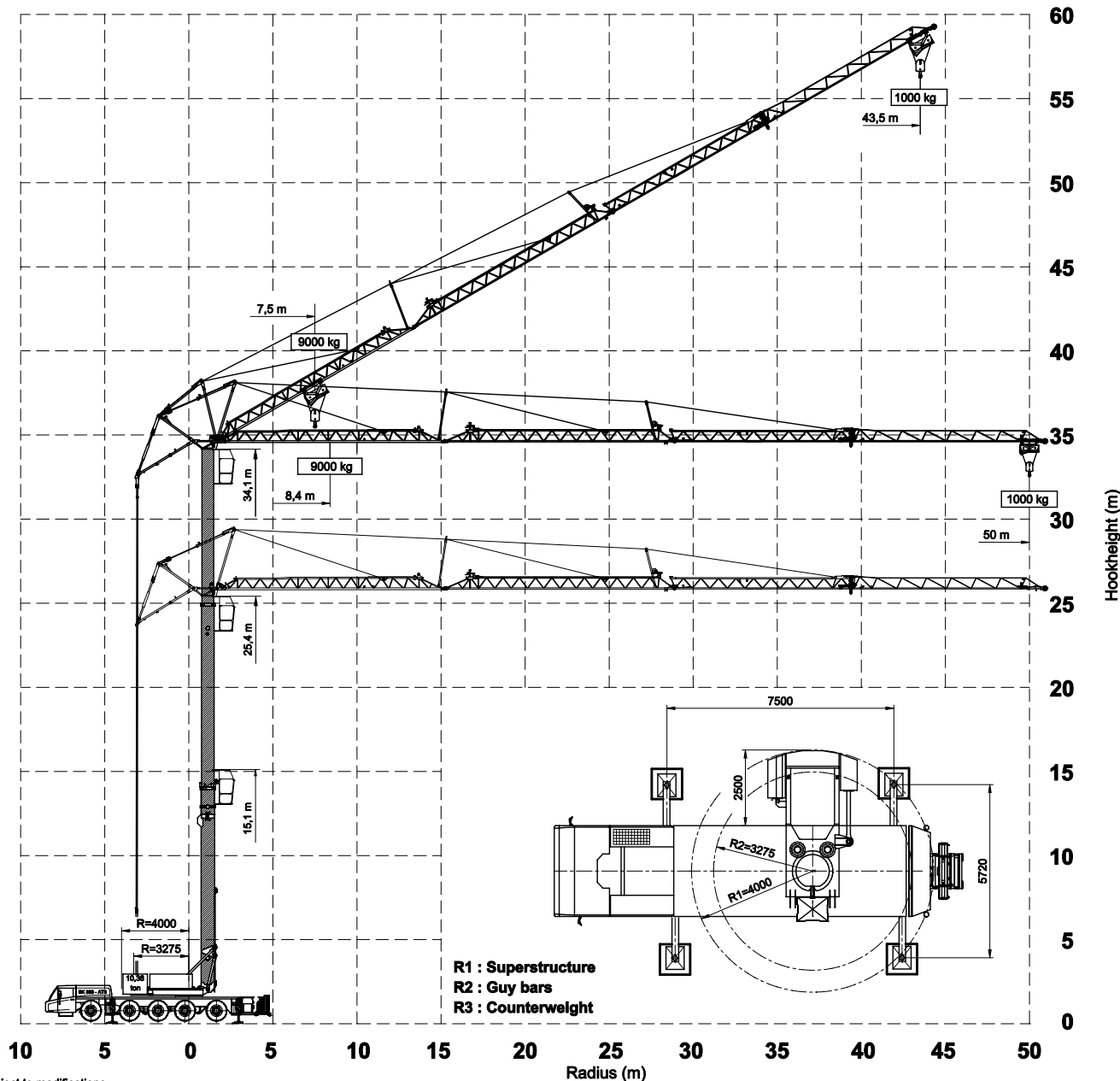

**SPIERINGS**  
MOBILE CRANES

Merwedestraat 15  
5347 KZ Oss NL  
Tel. +31 (0)412-626964  
Fax +31 (0)412-645299  
[www.spieringcranes.com](http://www.spieringcranes.com)

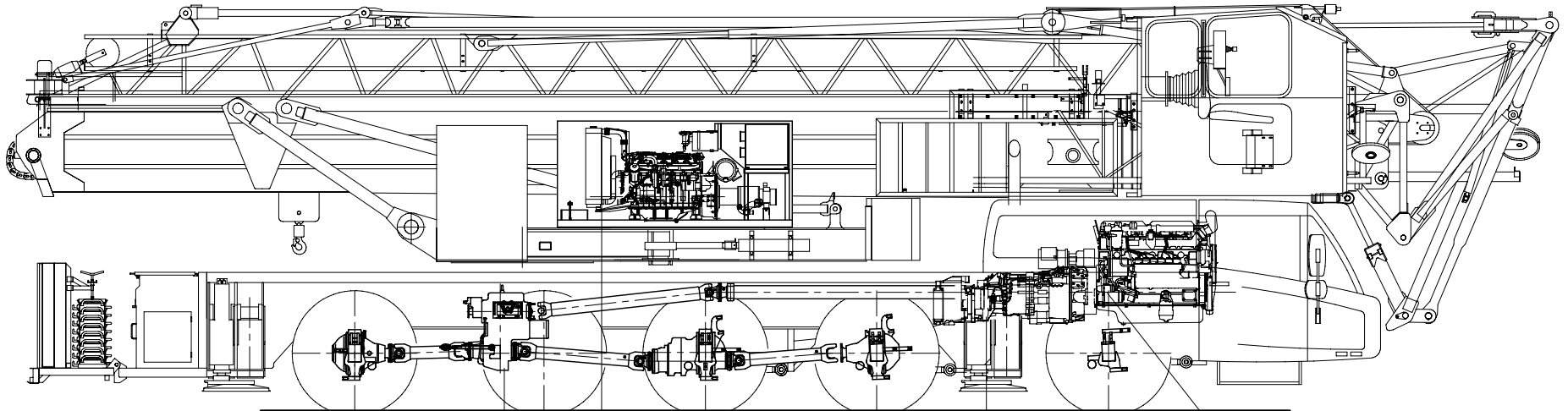

Axle 5		Axle 4		Axle 3		Axle 2		Axle 1	
Transfer box: STEYR VG2001/396		Crane diesel engine: John Deere 4045HF475		Gearbox: ZF 16AS2601		Carrier diesel engine: Euro IV		DAF: MX 375 (12,9 ltr)	
Road gear	i=0,89	Power: 129 kW (2200 rpm)	Automatic	Dry plate clutch	Power: 375 kW (1900 rpm)	Torque: 2500 Nm (1000-1410 rpm)			
Off road gear	i=1,54	Torque: 700 Nm (1400 rpm)	+ retarder						

Axle 1 : Steer axle	Tyres	: 445/75 R22,5
Axle 2 : Steer drive axle (end reduction i=7,29)	Suspension: hydro-pneumatic on all axles; stroke cyl.	: 247 mm
Axle 3 : Drive axle , non steered (end reduction i=7,29)	Max. speed carrier	: 85 km/h
Axle 4 : Steer axle	Min. speed carrier (engine at 1000 rpm)	: 1,6 km/h
Axle 5 : Steer drive axle (end reduction i=7,29)	Overall weight	: 60.000 kg.

## Drive train Spierings Folding Crane SK 599 - AT5

**SPIERINGS**  
MOBILE CRANES

Merwedestraat 15  
5347 KZ Oss NL  
Tel. +31 (0)412-626964  
Fax +31 (0)412-645299  
www.spieringscranes.com

# SPIERINGS

## HYDRAULIC FOLDING CRANE

### SK 599 - AT5

599xxx

#### Outrigger support base

Max. outrigger force	440 kN
Outrigger support pads	750x600 mm
Ground pressure	1,00 N/mm <sup>2</sup>
Outrigger support plates	1000x1000 mm
Surface	1,00 m <sup>2</sup>
Ground pressure	0,44 N/mm <sup>2</sup>

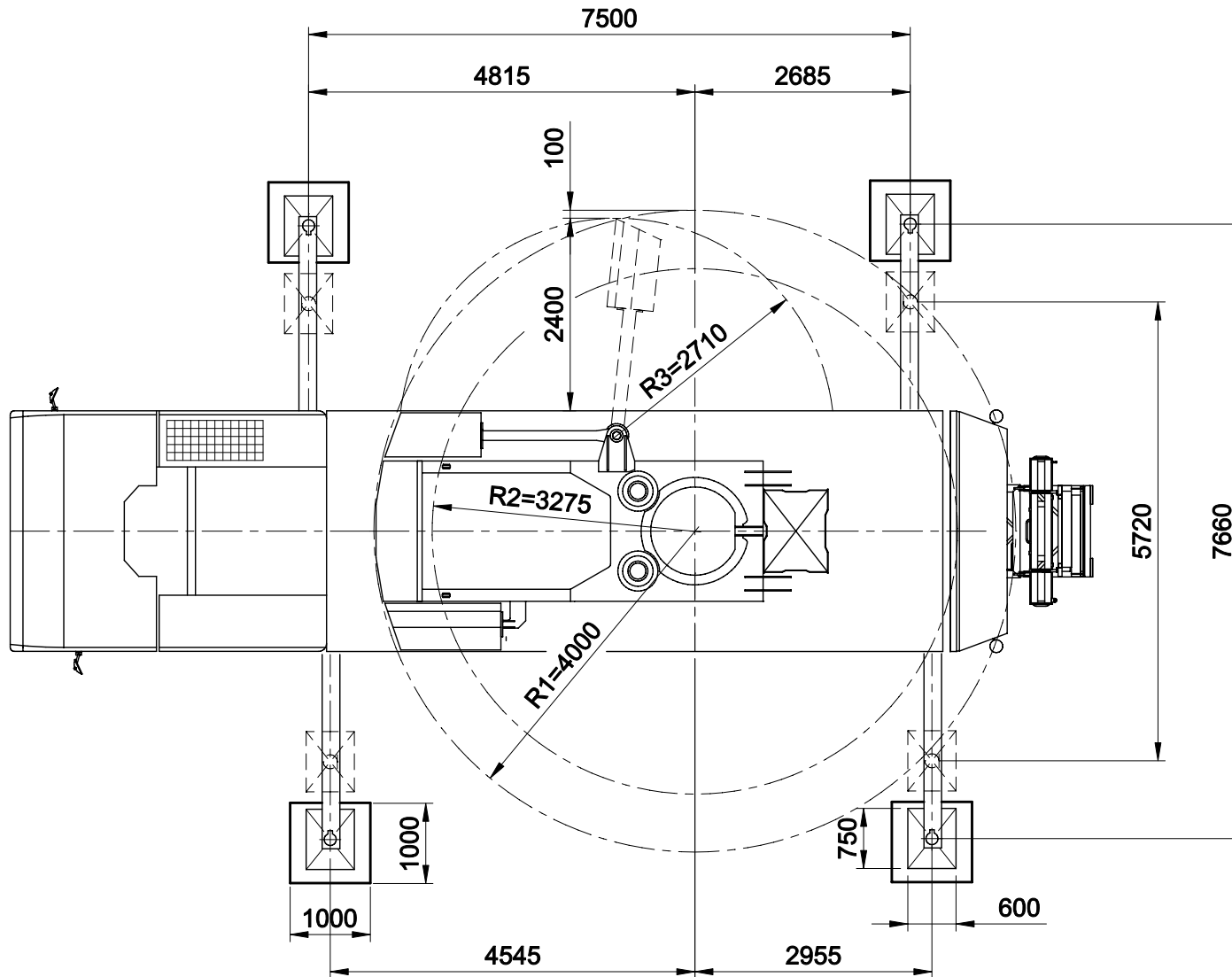

R1 : Superstructure  
 R2 : Guy bars  
 R3 : Counterweight

**SPIERINGS**  
 MOBILE CRANES

Merwedestraat 15  
 5347 KZ Oss NL  
 Tel. +31 (0)412-626964  
 Fax +31 (0)412-645299  
[www.spieringscranes.com](http://www.spieringscranes.com)

Specifications subject to change

Courtesy of **102-00599107**